

5G EVE

5G European Validation platform for Extensive trials

Deliverable D1.3

5G EVE end to end facility reference
architecture for vertical industries and core
applications

Project Details

<i>Call</i>	H2020-ICT-17-2018
<i>Type of Action</i>	RIA
<i>Project start date</i>	01/07/2018
<i>Duration</i>	36 months
<i>GA No</i>	815074

Deliverable Details

<i>Deliverable WP:</i>	WP1
<i>Deliverable Task:</i>	Task T1.2
<i>Deliverable Identifier:</i>	5G_EVE_D1.3
<i>Deliverable Title:</i>	5G EVE end to end facility reference architecture for vertical industries and core applications
<i>Editor(s):</i>	Ricardo Román
<i>Author(s):</i>	Ricardo Román, Manuel Lorenzo, Marc Molla (ERI-ES); Antonio Orlando (TIM); Lourdes Luque, Juan Rodríguez, Luis Miguel Contreras (TID); Eric Gatel, Michel Corriou, Sergio Morant (B-COM); Anna Sessler, Paolo Benfatto, Luca Stroppolo (ERI-IT); Ignacio Benito, Jaime Ruiz (NOK-ES); Giacomo Bernini, Giada Landi, Gino Carrozzo, Pietro Giardina (NXW); Rodolphe Legouable, Salvatore Costanzo, Mohamad Yassin, Sofiane Imadali, Ayoub Bousselmi, Louiza Yala (ORA-FR); Bogdan Rusti, Jean Ghenta, Marius Iordache, Elena Oproiu, Iulian Gimiga (ORA-RO); Ewelina Szczekocka, Grzegorz Panek, Michal Chabiera (ORA-PL); Jaime Garcia (U3CM); Kostas Trichias (WINGS), Vasilis Foteinos (WINGS), Panagiotis Vlacheas (WINGS)
<i>Reviewer(s):</i>	Ramón Pérez, Aitor Zabala (TELC)
<i>Contractual Date of Delivery:</i>	31/12/2019
<i>Submission Date:</i>	19/12/2019
<i>Dissemination Level:</i>	PU
<i>Status:</i>	1.0
<i>Version:</i>	Final
<i>File Name:</i>	5G EVE – D1.3 5G EVE end to end facility reference architecture for vertical industries and core applications

Disclaimer

The information and views set out in this deliverable are those of the author(s) and do not necessarily reflect the official opinion of the European Union. Neither the European Union institutions and bodies nor any person acting on their behalf may be held responsible for the use which may be made of the information contained therein.

Deliverable History

Version	Date	Modification	Modified by
V0.1	14/06/2019	First draft - TOC	Ricardo Román, All authors
V0.2	08/10/2019	First round of contributions	All authors
V0.3	10/10/2019	Integrated first round of contributors	Ricardo Román
V0.4	09/11/2019	Updated with editor feedback	Ricardo Román
V0.5	19/11/2019	Updated with all contributors' feedback	All authors
V0.6	20/11/2019	First integrated and complete version	Ricardo Román
V0.7	21/11/2019	Updated with all contributor's review comments	All authors
V0.8	22/11/2019	Updated with WP leaders' comments	Ricardo Román
V0.9	25/11/2019	Updated version for Internal Review	Ricardo Román
V1.0	12/12/2019	Final version addressing internal review comments	Ricardo Román

Table of Contents

LIST OF FIGURES	IX
LIST OF TABLES	XI
EXECUTIVE SUMMARY	12
1 INTRODUCTION	13
1.1 DOCUMENT STRUCTURE	15
2 5G EVE PLATFORM – EXPERIMENT FLOW	17
2.1 5G EXPERIMENT FLOW PHASES	18
2.1.1 5G Experiment Flow – Experiment Design.....	18
2.1.2 5G Experiment Flow – Experiment Preparation.....	22
2.1.3 5G Experiment Flow – Experiment Execution.....	23
2.1.4 5G Experiment Flow – Experiment Result Analysis.....	24
2.2 5G EXPERIMENT FLOW EXAMPLE	24
3 5G EVE PLATFORM – 5G KEY ENABLERS AND 5G CAPABILITIES	30
3.1 5G EVE PLATFORM –5G CAPABILITIES.....	30
3.2 5G EVE PLATFORM – 5G KEY ENABLERS	34
3.2.1 Network Slicing.....	34
3.2.2 Edge Computing.....	37
3.2.3 NFV/SDN	41
3.2.4 5G NR.....	44
4 5G EVE PLATFORM – ANATOMY	48
4.1 PHYSICAL INFRASTRUCTURE LAYER FUNCTIONS	49
4.2 NETWORK LAYER.....	52
4.2.1 RAN.....	54
4.2.2 Core.....	57
4.2.3 SDN Controller	59
4.3 MANAGEMENT AND ORCHESTRATION LAYER	59
4.4 INTERWORKING LAYER.....	62
4.4.1 Multi-site Catalogue	64
4.4.2 Multi-site Inventory.....	64
4.4.3 Multi-site Network Orchestrator (MSNO)	64
4.4.4 Runtime Configurator	65
4.4.5 Data Collection Manager	65
4.4.6 I/W Framework Requirements on Sites Capabilities.....	66
4.5 5G EVE PORTAL (SERVICE LAYER).....	66
4.5.1 Experiment Design Tools	67
4.5.2 Run Experiment Tools.....	68
4.5.3 Experiment Monitoring Tools	69
5 5G EVE PLATFORM - ADDED-VALUES	71
5.1 INTENT-BASED INTERFACE TOWARDS VERTICALS.....	71
5.2 MULTI-SITE MULTI-DOMAIN SLICING AND ORCHESTRATION	74
5.3 PERFORMANCE DIAGNOSIS (KPI FRAMEWORK).....	75
5.4 5G VNFs (OPENNESS FRAMEWORK).....	79
6 5G EVE PLATFORM - DYNAMICS	81
6.1 INTERACTIONS BETWEEN 5G EVE USERS AND 5G EVE PLATFORM	81
6.1.1 Experiment Design.....	81
6.1.2 Experiment Preparation and Execution.....	83
6.2 INTERFACES	87
6.2.1 Vertical and Experiment Developer Interfaces	87
6.2.2 5G EVE Platform Control Plane Interfaces.....	88
6.2.3 5G EVE Platform User Plane Interfaces	89

CONCLUSIONS	91
ACKNOWLEDGMENT	92
REFERENCES	93
ANNEX A.1 EXPERIMENT TEMPLATE FOR VERTICALS	97
ANNEX A.2 EXAMPLE OF LOW LEVEL TEST PLAN TEMPLATE	99
ANNEX A.3 EXAMPLE OF VSB	100
ANNEX A.4 EXAMPLE OF CB	102
ANNEX A.5 EXAMPLE OF EXPB	104
ANNEX A.6 EXAMPLE OF TCB.....	106
ANNEX A.7 EXAMPLE OF EXPD.....	107
ANNEX A.8 EXAMPLE OF NSD.....	109

List of Acronyms and Abbreviations

<i>Acronym</i>	<i>Meaning</i>
AA	Application Assurance
ADC	Application Detection and Control
AF	Application Function
AGV	Automated Guided Vehicle
AMF	Access and Mobility Management function
API	Application Programming Interface
BBU	Baseband Unit
BFD	Bidirectional Forwarding Detection
BGP	Border Gateway Protocol
BSS	Business Support Systems
CIoT	Cellular IoT
C-SGN	Cellular Serving gateway node
CB	Context Blueprint
CM	Configuration Management
CNF	Cloud-Native Functions
CI/CD	Continuous Integration/Continuous Delivery
CN	Core Network
CoS	Class of Service
CP	Control Plane
CPRI	Common Public Radio Interface
CRUD	Create, Read, Update, and Delete
CSC	Communication Service Customer
CSP	Communication Service Provider
CU	Centralized Unit
CUPS	Control and User Plane Separation
DCN	Data Centre Network
DF	Deployment Flavour
DevOps	Development/Operations
DSCP	Differentiated Services Code Point
DU	Distributed Unit
E2E	End-to-end
eMBB	Enhanced Mobile Broadband
eCPRI	Evolved Common Public Radio Interface
EPC	Evolved Packet Core
ETSI	European Telecommunications Standards Institute
ExpB	Experiment Blueprint
ExpD	Experiment Descriptor
FDD	Frequency Division Duplex
FM	Fault Management
5G	Fifth Generation
4G	Fourth Generation
GUI	Graphical User Interface
ETSI ISG MEC	Industry Specification Group for Multi-access Edge Computing

<i>IMT</i>	International Mobile Telecommunications
<i>ITU</i>	International Telecommunication Union
<i>IoT</i>	Internet of Things
<i>KPI</i>	Key Performance Indicator
<i>I-RAT</i>	Inter-Radio Access Technology
<i>IL</i>	Instantiation Level
<i>LCM</i>	Life-Cycle Management
<i>LTE</i>	Long Term Evolution
<i>MAC</i>	Medium Access Control
<i>MANO</i>	Management and Orchestration
<i>MEC</i>	Multi-access Edge Computing
<i>MIMO</i>	Multiple-Input Multiple-Output
<i>MME</i>	Mobility Management Entity
<i>mMTC</i>	Massive Machine-Type Communications
<i>MT</i>	Mobile Terminal
<i>MTC</i>	Machine-Type Communications
<i>MPLS</i>	Multiprotocol Label Switching
<i>MSNO</i>	Multi-Site Network Orchestrator
<i>NAS</i>	Non-Access Stratum
<i>NF</i>	Network Function
<i>NFV</i>	Network Function Virtualization
<i>NFVI</i>	NFV Infrastructure
<i>NFVO</i>	NFV Orchestrator
<i>NFVI-PoPs</i>	NFVI Points of Presence
<i>NEF</i>	Network Exposure Function
<i>N-PoP</i>	Network Point of Presence
<i>NRF</i>	Network Resource Function
<i>NS</i>	Network Service
<i>NSD</i>	Network Service Descriptor
<i>NSI</i>	Network Slice Instance
<i>NSSAI</i>	Network Slice Selection Assistance Information
<i>NSSF</i>	Network Slice Selection Function
<i>NSSI</i>	Network Slice Subnet Instance
<i>NR</i>	New Radio
<i>NRF</i>	Network Repository Function
<i>NSA</i>	Non-Stand Alone
<i>OAI</i>	Open Air Interface
<i>OAM</i>	Operations, Administration, and Maintenance
<i>OIF</i>	Optical Internetworking Forum
<i>ONAP</i>	Open Networking Automation Platform
<i>ONF</i>	Open Networking Forum
<i>OpenSSH</i>	OpenSSH (Open Secure Shell)
<i>OSI</i>	Open System Interconnection
<i>OSPF</i>	Open Shortest Path First
<i>OSS</i>	Operations Support System
<i>PCF</i>	Policy Control Function
<i>PDCCP</i>	Packet Data Convergence Protocol

<i>PDU</i>	Packet Data Unit
<i>PDP</i>	Packet Data Protocol
<i>PHY</i>	Physical Layer
<i>PM</i>	Performance Management
<i>PNFD</i>	Physical Network Function Descriptor
<i>QFI</i>	QoS Flow Identifier
<i>QoS</i>	Quality of Service
<i>RAN</i>	Radio Access Network
<i>RBAC</i>	Role-Based Access Control
<i>RLC</i>	Radio Link Control
<i>RRC</i>	Radio Resource Control
<i>ROHC</i>	Robust Header Compression
<i>SBA</i>	Service Based Architecture
<i>SBI</i>	Service-Based Interface
<i>SDAP</i>	Service Data Adaptation Protocol
<i>SDN</i>	Software Defined Networks
<i>S-GPRS</i>	Serving General Packet Radio Service
<i>SGSN</i>	Serving GPRS Support Node
<i>SM</i>	Session Management
<i>SMF</i>	Session Management Function
<i>S-NSSAI</i>	Single Network Slice Selection Assistance Information
<i>SA</i>	Stand-Alone
<i>TDD</i>	Time Division Duplex
<i>TC</i>	Test Case
<i>TCB</i>	Test Case Blueprint
<i>3GPP</i>	Third Generation Partnership Project
<i>TDF</i>	Traffic Detection Function
<i>TEID</i>	Tunnel Endpoint Identifier
<i>TN</i>	Transport network
<i>UDM</i>	Unified Data Management
<i>UE</i>	User Equipment
<i>UP</i>	User Plane
<i>UPF</i>	User Plane Function
<i>URLLC</i>	Ultra-Reliable and Low Latency Communications
<i>VIM</i>	Virtual Infrastructure Manager
<i>VL</i>	Virtual Link
<i>VLD</i>	Virtual Link Descriptors
<i>VM</i>	Virtual Machine
<i>VNF</i>	Virtual Network Function
<i>VNFD</i>	Virtual Network Function Descriptor
<i>VNFFGD</i>	VNF Forwarding Graph Descriptors
<i>VPN</i>	Virtual Private Network
<i>VSB</i>	Vertical Service Blueprint
<i>WIM</i>	WAN Infrastructure Manager
<i>WRC</i>	World Radiocommunication Conference

List of Figures

Figure 1: 5G EVE Experiment Flow	13
Figure 2: High Level - 5G EVE functional architecture	14
Figure 3: 5G EVE validation test process phases.....	17
Figure 4: 5G EVE Experiment Flow - Experiment Design Activities	18
Figure 5: 5G EVE Experiment Flow - Experiment Preparation Activities	22
Figure 6: 5G EVE Experiment Flow - Experiment Execution Activities	23
Figure 7: 5G EVE Experiment Flow - Experiment Result Analysis Activities.....	24
Figure 8: Example of "Experiment Template" filled by ASTI.....	25
Figure 9: Example of "Low Level Test Plan Template"	26
Figure 10: Example of monitored information.....	29
Figure 11: Mobile service generations	30
Figure 12: IMT 2020 eMBB, URLLC and mMTC usage scenarios	31
Figure 13: Mapping of Use Case 5a, 4G and 5G performance requirements.....	32
Figure 14: Network Slice related information model in 3GPP TR 28.801 [25].....	35
Figure 15: NSI X and Y composed by NSSI A, B and C [25]	35
Figure 16: ETSI NFV enablement.....	37
Figure 17: AF re-location in a mobility UE environment	38
Figure 18: Distributed Cloud [29]	39
Figure 19: MEC architecture [30]	40
Figure 20: 5G Service Based Architecture (SBA) and MEC Architecture	40
Figure 21: Vision for Network Functions Virtualization [32].....	42
Figure 22: High level VNF Framework	44
Figure 23: 3GPP Release Freeze and End dates [33]	44
Figure 24: 5G NSA Architecture.....	45
Figure 25: 5G SA Architecture.....	45
Figure 26: Overall NR architecture	46
Figure 27: Rel-16 NR Work Items [35].....	46
Figure 28: 5G EVE functional architecture.....	48
Figure 29: 5G PPP - 5G Overall architecture Framework.....	49
Figure 30: End-to-end network architecture (simplified view)	50
Figure 31: SDN-based RAN Approach.....	51
Figure 32: 5G System Architecture [42]	53
Figure 33: 3GPP deployments using network slicing [43].....	54
Figure 34: User plane protocol stack.....	54
Figure 35: Mapping of QoS flows on DRBs	55

Figure 36: Option 3x - 5G NSA	55
Figure 37: Option 3a - 5G NSA	56
Figure 38: Option 3 - 5G NSA	56
Figure 39: Option 5 - 5G SA	57
Figure 40: Option 2 - 5G SA	57
Figure 41: Slice Selection.....	58
Figure 42: Example of coordination between 3GPP and TN management systems [45].....	59
Figure 43: Mixed network management mapping relationship between 3GPP and NFV-MANO architectural framework [45].....	60
Figure 44: NSs provided using multiple administrative domains [47].....	62
Figure 45: I/W Framework Upper/Lower Layers.....	63
Figure 46: Major components of 5G EVE portal and their association to the experiment lifecycle.....	67
Figure 47: IBI GUI Intent based interface with an example of Free Text intent.....	72
Figure 48: Example of additional information requested to the <i>Vertical</i>	72
Figure 49: IBI Portal Guided Selection Interface	73
Figure 50: Example of fields to be filled for expressing the intent through the Guided Selection Interface	73
Figure 51: 5G EVE platform modules interaction - KPI handling process	76
Figure 52: 5G EVE testing Framework tools	78
Figure 53: 5G EVE KPI sources and KPI collection interfaces [6]	78
Figure 54: 5G EVE testing Framework tools components.....	79
Figure 55: Experiment definition workflow	81
Figure 56: Experiment preparation workflow	83
Figure 57: Experiment execution workflow	85
Figure 58: 5G EVE Architecture - Verticals' View	87
Figure 59: Experiment template for verticals	98
Figure 60: Example of Low Level Test Plan Template.....	99

List of Tables

Table 1: 5G EVE Platform actors.....	14
Table 2: Example of Description of Vertical Service Blueprint.....	27
Table 3: Description of Experiment Descriptor	27
Table 4: 5G EVE use cases and requirements mapping.....	31
Table 5: 5G Key Capabilities availability in 5G EVE.....	32
Table 6: ICT-18/19 Projects – Vertical's/Use Cases.....	33
Table 7: Orchestrator's Technologies / SDN Technologies.....	42
Table 8: Experiment definition messages.....	82
Table 9: Experiment preparation messages	84
Table 10: Experiment execution messages.....	86

Executive Summary

5G commercial network rollout is already happening in Europe and vertical industry companies from different sectors have a need to test their 5G-based applications in a 5G-enabled infrastructure flexible enough to reproduce different live network operation conditions, in order to ensure successful commercialization.

5G Infrastructure PPP Phase 2 projects (2017-2019) [1] contributed to the prototyping, experimentation and trialling of 5G technologies and components for specific use-cases but it is in 5G Infrastructure PPP Phase 3 projects [2] like 5G EVE where 5G components and technologies are integrated together to provide the end-to-end (E2E) facility with the scope to support verticals to run their tests.

This deliverable describes the 5G end-to-end facility architecture that will be supported in the project for the vertical industries. The document first introduces the Actors participating in the Experiment Flow, next, detailed information of each of the Experiment Flow phases including inputs, actors involved and outputs of each of them is provided, and finally, the 5G end-to-end facility architecture supporting the Experiment Flow is fully described.

The description of 5G end-to-end facility architecture approach proposed in this document not only includes a description of each 5G EVE platform functional layer and blocks included on each layer, but also information about 5G key features deployed which enrich the 5G EVE platform with 5G capabilities required to fulfill experiment requirements of the use cases described by the Verticals in D1.1 [3]. The 5G key features described include novel technologies like network slicing, programmability, virtualization, edge computing and 5G NR.

Different topology views and workflows depicting internal processes within the 5G EVE platform and interactions between different actors and the 5G EVE platform are also included for a better understanding. Finally, examples of templates for the different blueprints that will be used along the Experiment Flow process are included in the Appendix.

5G EVE end-to-end facility will start from being compliant with 3GPP Release 15 [4] and will evolve in time along the project time schedule in terms of technologies and encompass with 3GPP evolutions in order to achieve performance expectations envisioned for 5G. Connected to that, the availability of 5G EVE platform capabilities described in this document, and linked to such technology evolution, might change in case of external factors (interoperability issues between vendors, 5G devices availability, frequency auctions not celebrated according to initial plans,...), finally impacting in the expected deployment readiness.

5G Non-Stand Alone (NSA) commercial networks already exist in the world, but the big challenge is in the 5G Stand-Alone (SA) solutions where a new core network (5GC) has been designed to fulfil IMT-2020 [5] performance requirements expectations for innovative use cases and applications to come. Therefore, products developed for new 5GC could not have during first coming months the stability and maturity required for its commercial use, and so, it may introduce some limitations during the execution of trials and use cases using 5G systems.

Nevertheless, difficulties faced in coming months along the project execution will be very fruitful to support SDOs into standardization document / solutions review, provide stakeholders (verticals / operator and vendors) a clear picture of solutions / technologies maturity level that will, and so, aligned to one of the objectives of 5G EVE, help 5G ecosystem players to update their commercial and so, business goals; and be instrumental towards the pervasive roll-out of 5G end-to-end networks in Europe.

1 Introduction

Deliverable D1.3 – 5G EVE end to end facility reference architecture for vertical industries and core applications – represents the main outcome of Task 1.2 and describes the 5G end-to-end facility architecture that will be supported in the project facility for the vertical industries to run their experiments.

It is expected that this will be the first document the *Vertical / Experimenter* consults when approaching to 5G EVE project to understand what 5G EVE platform offers and how it can be used. This document has been written with that in mind, so that it starts describing the Experimentation Flow and Actors involved in the different phases. The document also includes technical information of different technologies and platform components, as needed to understand how the platform works, the platform capabilities and how *Vertical / Experimenter* uses and interacts with the platform to run the experiments. Finally, references to SDOs documentation and other 5G EVE deliverables where further technical information can be found by the reader if required are also included.

The following two figures provide a good understanding of how, at high level, 5G EVE platform is used within the Experimentation Flow and the functional architecture of the platform:

- Figure 1 shows the Experiment Flow Activities”, depicting actors, inputs/outputs and main activities of each of the four phases the Experiment Flow process is being split.

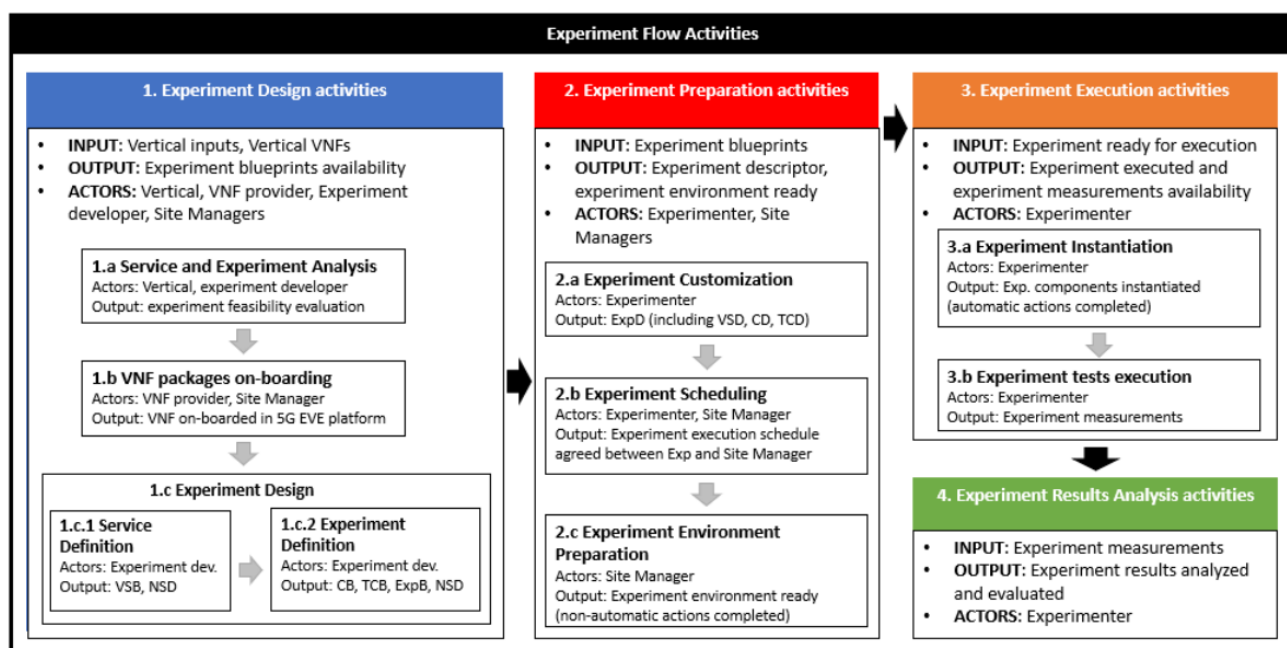

Figure 1: 5G EVE Experiment Flow

- Figure 2 shows a high-level overview of the 5G EVE functional architecture main blocks.

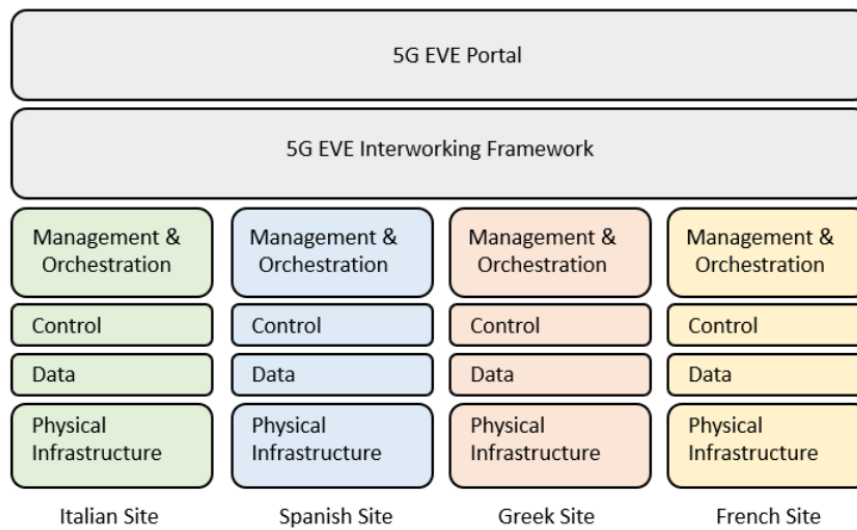

Figure 2: High Level - 5G EVE functional architecture

Main Actors have been identified in D4.1 [6]. For better understanding this document, information related to each actor specific role and target actions that can perform is included in Table 1:

Table 1: 5G EVE Platform actors

Actor	Description	Target actions
<i>Anonymous user</i>	User not authenticated to the Portal	No actions are allowed.
<i>VNF provider</i>	Actor who provides the Virtual Network Function (VNF) packages for the vertical applications.	<ul style="list-style-type: none"> - Uploading of VNF packages in 5G EVE portal. - Issuing of requests (via 5G EVE portal) for VNF packages on-boarding to specific sites.
<i>Vertical</i>	Actor with the knowledge of the service to be tested, including SLAs and service components.	<ul style="list-style-type: none"> - Support in the definition of the vertical service blueprints and related experiments.
<i>Experiment developer</i>	<p>Actor responsible for specifying the blueprints associated to an experiment, as well as the associated NFV network services descriptors.</p> <p>This user has the knowledge about the 5G EVE infrastructure and expertise about NFV network service modelling. Moreover, it interacts with the vertical to receive information about the details of the target service.</p>	<ul style="list-style-type: none"> - Modelling and definition of blueprints for vertical services, experiment contexts and experiments. - Modelling and definition of NFV Network Service Descriptors (NSD) associated to the experiment blueprints, as well as related translation rules. - Definition and development of mechanisms for collecting application-level metrics from the vertical service. - On-boarding of blueprints via 5G EVE Portal.

		<ul style="list-style-type: none"> - On-boarding of NFV Network Service Descriptors via 5G EVE Portal.
<i>Experimenter</i>	Actor responsible for the request of an experiment and the assessment of its results. He/she defines characteristics of an experiment starting from its blueprint, requests the deployment of related virtual environment and experiment execution and analyses results and KPIs.	<ul style="list-style-type: none"> - Selection of blueprints for the target vertical service and experiment, via 5G EVE Portal. - Configuration of the experiment, according to the blueprint parameters, via 5G EVE Portal. - Issuing of requests, via 5G EVE Portal, for scheduling the execution of the experiment in the 5G EVE facilities. - Monitoring of the experiment execution, via 5G EVE Portal. - Visualization of experiment measurements, KPIs and results, via 5G EVE Portal.
<i>Site manager</i>	Actor responsible for the management of the infrastructure and the orchestration systems in a particular site.	<ul style="list-style-type: none"> - Pre-provisioning and configuration of the physical infrastructure in the managed site. - Validation and on-boarding of VNF packages. - Preparation of resources needed to deploy an experiment.
<i>System administrator</i>	Actor who has access to all tools provided by the 5G-EVE project.	All actions, including management functions (e.g. configuration of users and permissions, visualization of system logs, etc.). Note: the system administrator may have a limited access to the management system of the single site facilities.

1.1 Document structure

The document is structured in the following way:

- **Section 2 – 5G EVE platform - Experiment Flow**

In this section, the main four phases in which the Experiment Flow is split are described. For each phase, a full description of the different activities / tasks, actors, inputs/outputs are included. Additionally, when the execution of an activity is supported by some platform capabilities / tools, the information of when that is planned to be available is included as well.

- **Section 3 – 5G EVE platform - 5G Key enablers and 5G Capabilities**

5G EVE platform is built to support the execution of experiments in a 5G network. 5G networks will support end-user's performance requirements demands envisioned for IMT-2020 systems. Back in late 2017, an initial release (Rel-15) of 5G standards were released to support some of these functionalities / performance requirements, but it is not until early 2020, when Rel-16 will be released, for an initial completion of a full set of 3GPP 5G system specifications.

Additionally, beyond that, continuous work for the enhancement of released functionalities and development of new ones are expected to improve 5G networks performance across time. Because of this, not all envisioned 5G network performance capabilities and features will be available from the beginning in 5G EVE platform, and it is in section 3 where the availability expected for each of them is described. Note also that some innovative features / solutions are considered key enablers to achieve 5G networks expected performance. These features are also described in this section. Not only a features description is included, but also, how these will be deployed/implemented in 5G EVE platform.

- **Section 4 – 5G EVE Platform – Anatomy**

In this section, 5G EVE Platform functional layers and blocks are described. In addition to the description of main functions of each block, information of solutions available in 5G EVE platform is also included. Note that the implementation of each solution can be different on each site, using different technologies. Detailed information of technologies available at each 5G EVE site is included in deliverables D2.1 [7] and D2.2 [8].

- **Section 5 – 5G EVE Platform - Added-values**

In this section, the main innovation areas addressed in 5G EVE are described. 5G EVE platform add a very important value to the *Vertical / Experimenter* along the whole experimentation flow process. Starting from the Experiment design phase where 5G EVE innovative tools and mechanisms are implemented to facilitate the design and definition of the experiment using an intuitive language (Intent-based) but also, allowing *Vertical* to identify and select from a vast number of technologies available in the 5G EVE platform catalogues. *Vertical* can also upload its VNFs in the 5G EVE platform to be used during the experiment execution, and a during experiment execution, 5G EVE platform facilitates a Key Performance Indicator (KPI) monitoring and collecting framework to facilitate not only the visualization of experiment execution, but also to get detailed information of experiment execution results and a performance diagnosis report for the KPIs where targets were not achieved.

- **Section 6 – 5G EVE platform – Dynamics**

This section covers the interaction between the 5G EVE platform and the actors using it. Workflows also show system administration (e.g. on-boarding of local Virtual Network Function Descriptor (VNFD), definition of blueprints for the services, etc.) and experiment management procedures (e.g. definition of experiment, request the execution of the experiment, etc.). Finally, in this section, the interfaces exposed by each functional component to enable the workflows identified above are described.

Finally, the annexes include examples of blueprints and document templates referred along the project.

2 5G EVE platform – Experiment Flow

5G EVE Platform will be used by different Vertical industries to run their experiments in a 5G enabled infrastructure to discover and evaluate the value-adding business potential of a 5G mobile network when applied to Vertical services. Usually, the execution of Experiments and associated test cases are structured in four main phases as shown in Figure 3 below.

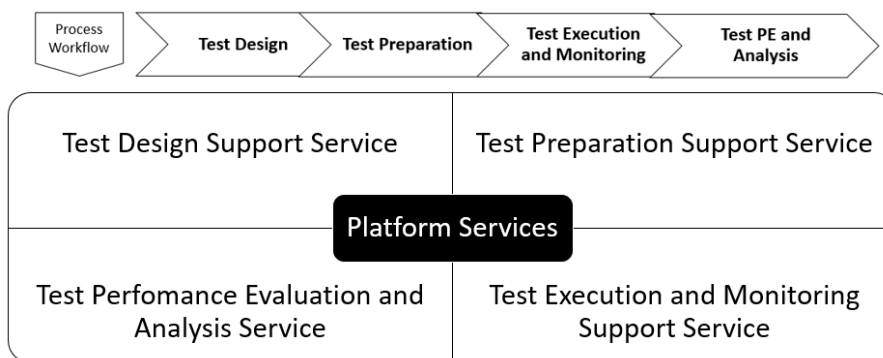

Figure 3: 5G EVE validation test process phases

Along the experiment flow process, an active dialogue between Verticals and 5G EVE Platform stakeholders make possible to come to a full reciprocal understanding of 5G EVE platform capabilities and Vertical use cases requirements and agree on the trial specifications including the use cases to be validated, scenarios covered, interfaces used, metrics and KPIs measured, etc.

This will then be materialized in experiments’ design and development activities that will provide Verticals with a tailor-made 5G virtual infrastructure to run their experiments. Experiment execution will support Verticals to validate their applications in customized scenarios to simulate the characteristics expected in real commercial deployments. This approach will allow Verticals to collect the measurements needed to fully assess the performance of their services in scenarios replicating realistic operational environments, with the final objective of tuning the configuration of their applications to meet the conditions and characteristics of different deployment options, thus maximizing the efficiency of the service roll-out phase.

In this sense, it is key to fully describe the Experiment Flow phases including:

- What - Activities included, inputs and expected outputs.
- Who - 5G EVE platform main stakeholders and actors.
- How - Process and procedures.
- When – 5G EVE platform availability.

The results achieved will help Verticals to build their business solutions in 5G commercial networks implementing 5G standards releases, where early 5G commercial deployments have been envisioned during 2019, and mass roll-out is expected in 2020 implementing a complete 5G standard (3GPP Rel-16) that fully satisfies all of the ITU requirements for IMT-2020 systems [5]

The challenge is to provide a 5G infrastructure that has the capacity, capability, reliability, availability, and security to support UCs defined by the Verticals using 5G EVE as the experimentation platform to run their experiments.

The Experiment Flow phases and main activities were depicted in Figure 1. For each phase, next sections provide a general description of the process, information of activities included, inputs/outputs, actors involved and availability. Further, in section 6 “Dynamics”, procedures are detailed using workflows diagrams.

2.1 5G Experiment Flow Phases

2.1.1 5G Experiment Flow – Experiment Design

In this phase, *Vertical* and other specialized actors, like *VNF provider* and *Experiment developer*, cooperate to identify the major characteristics, objectives and KPIs of the experiment related to a vertical service. Figure 4 highlights in yellow the main Experiment Design activities.

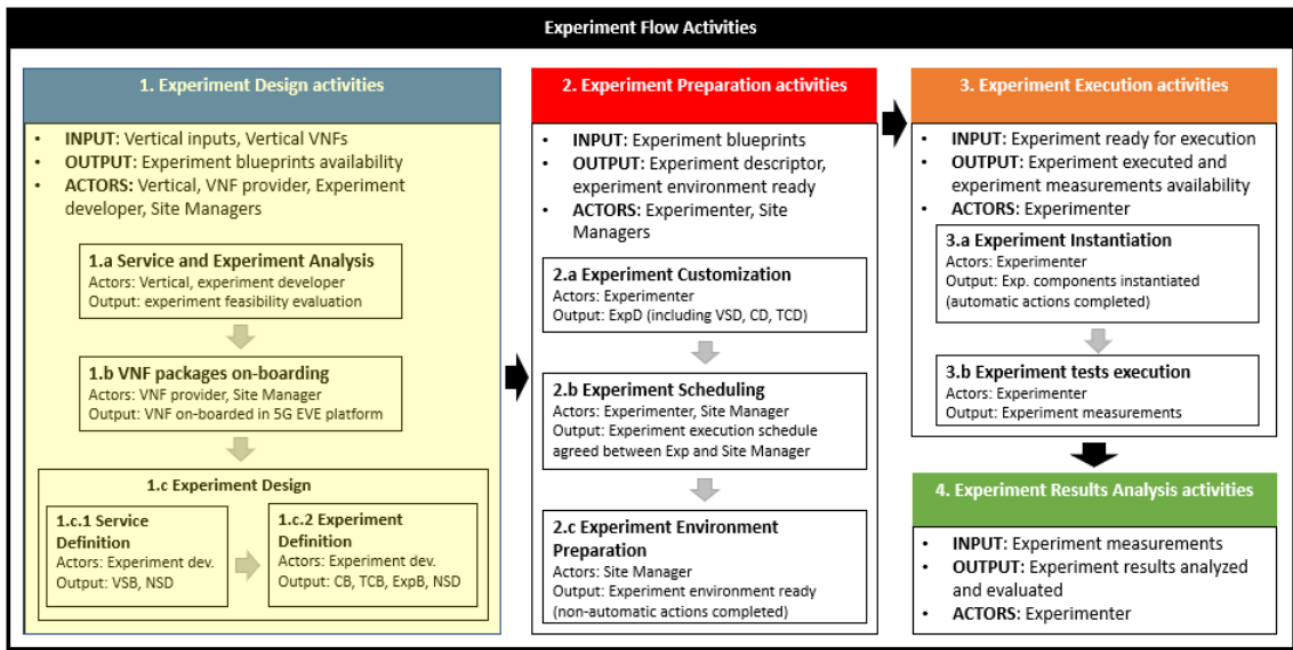

Figure 4: 5G EVE Experiment Flow - Experiment Design Activities

This preliminary, high-level design is then formalized into a well-structured definition of the experiment, producing the “templates” that describe the target environment and the execution steps to run the tests and evaluate their results. The output of this phase consists of several blueprints modeling the components and the procedures of the experiment (jointly collected in the so-called Experiment Blueprint – ExpB), successfully onboarded in the 5G EVE platform and available for the experimenters.

As backend part of the blueprints, the experiment definition provides also the technical, low-level descriptors to automate the instantiation, configuration, execution, and monitoring of the experiment. Such descriptors are provided in the form of European Telecommunications Standards Institute (ETSI) Network Function Virtualization (NFV) descriptors for the Network Service (NS), Physical Network Functions (PNFD) and Virtual Network Functions (VNFD), expressed in TOSCA language and following the standard models defined in the ETSI GS NFV-SOL 001 specification [9].

Moreover, the scripts for the test case execution are also defined and on-boarded in the system as part of the Test Case Blueprint (TCB).

The experiment design and definition phase include several steps, involving the active operation of different actors. The major steps that we can identify are the following:

- **Service and experiment analysis:** *Vertical* exchanges information with the *Experiment developer* and the 5G EVE technicians about the service to be tested, its requirements (Service Level Agreement (SLA)s, components, metrics, etc.) and the objective of the experiment.

First, this description is formalized using a pre-defined template “Experiment Template”¹ used to evaluate the feasibility of the experiment in the 5G EVE facilities. This template filled by the *Vertical* contains a form with different questions that will help the *Experiment Developer* to understand its experiment needs. These questions are formulated in a concise and simple language for better *Vertical* understanding.

The following documentation is also available during this phase to help in this task:

- "D1.3 - 5G EVE end to end reference architecture for vertical industries and core applications" (this document), which describes 5G EVE platform architecture and capabilities for Verticals to get a full understanding of possibilities offered by 5G EVE platform;
- "D1.1 - Requirements definition and analysis from participant vertical industries" [3], which includes information of requirements from reference use cases covering main 5G segments and key vertical industries;
- "D1.4 - KPI collection Framework" [10], which describes 5G E2E KPIs that will be used to monitor E2E 5G service performance and supports Verticals to validate their use cases using either 5G E2E KPIs or *Vertical* KPIs that can be mapped to them; and
- "D2.1 - Initial detailed architectural and functional site facilities description" [7], which includes low-level details of specific sites facilities implementation of technologies, cloud and network infrastructure.

Second, *Experiment Developer* will translate the content in the “Experiment Template” filled by *Vertical* into a second template “Low Level Test Plan Template”². In this template, the experiment is defined in a technical language that is the input for the next phase.

- **VNF packages on-boarding:** *VNF provider* uploads into the 5G EVE platform the VNF packages necessary to run the experiments, using the 5G EVE Portal that provides a single point of access to the platform. “*VNF provider*” is planned to have access to 5G EVE Platform in M18 (Dec-2019).

After the approval and the preliminary validation of the VNF packages by the *Site Manager*, the Virtual Machine (VM) images are loaded in the cloud/edge infrastructures of the target 5G EVE facilities and the VNFDs are onboarded in the related NFV Orchestrators, becoming automatically available at the Interworking (I/W) Framework Catalogue. Depending on the experiment design, the *Vertical* identifies the sites where the VNFs are going to be onboarded.

The VNF package onboarding is requested through the 5G EVE Portal and “Ticketing system tool”³ is used for the interaction between *VNF provider* and site manager. Ticketing system Tool is available in 5G EVE platform from M16 (Oct-2019) through Open Interfaces and in M18 (Dec-2019) also thru 5G EVE Web Portal.

When the *VNF provider* uploads the VNF package in the 5G EVE Portal web Graphical User Interface (GUI), the platform creates a ticket for the site manager(s). Upon approval, the *Site manager* uploads the VNF package in the selected facility, using its own site-specific procedures. This action triggers automatically the onboarding of the VNFD at the I/W Framework Multi-Site Catalogue, becoming visible at the 5G EVE Portal as well. Ticketing system tool is then used to explicitly notify to *VNF Provider* about the successful onboarding and the *Vertical* can visualize VNFs available in the Platform using the “Browse and Lookup Tool” of the 5G EVE Portal.

The available VNFs are stored in I/W Framework catalogue following the format specified in ETSI GS NFV-SOL 004 [11] and ETSI GS NFV-SOL 001 [9].

¹ Note: [Annex A.1](#) includes an example of an Experiment Template for Verticals.

² Note: [Annex A.2](#) includes an example of a Low Level Test Plan Template.

³ Note: 5G EVE portal platform tools are described in section 4.5

- **Experiment Design:** in this activity, managed by the *Experiment Developer*, the templates for the experiment and the test cases associated with the experiment that can be executed in the 5G EVE environment are formally defined, on-boarded and validated in the 5G EVE Platform as blueprints. It should be noted that experimenters can re-use the same blueprint to replicate tests with different settings of the environment, the background conditions or the vertical application configurations, allowing to assess and compare the performance of the same service in different deployments, facilitating the tuning process.

The blueprints include a wide range of variable parameters that *Experimenter* will fill-in with missing information during the Experiment Customization phase to create the associated descriptors, finally ending up in an ExpD generated to be run during the execution phase.

The experiment definition activity includes two major steps, as follows:

- **Service Definition:** the *Experiment developer* creates the *Vertical Service Blueprint (VSB)* (if not yet existing) based on information provided by the *Vertical* in the previous high-level service design.

A VSB⁴ is a template to capture *Vertical Service* requirements using a well-specified language and data model that can be automatically processed by the system. *Vertical* service blueprint contains list of vertical services with a wide range of configurable parameters to enable the service tuning.

The VSB format used in 5G EVE is derived from the modelling of VSBs adopted in 5G-TRANSFORMER [12], with minor updates to cover 5G EVE requirements. The VSBs onboarded in the platform are stored in the 5G EVE Portal catalogue and can be accessed through the 5G EVE Portal.

- **Experiment Definition:** The *Experiment developer* defines the experiment and the associated Test Cases (TC)s, formalizing them in the ExpB. In this step, the *Experiment developer* may also create new Context Blueprints (CB)s be associated to the VSB, if not yet existing. A CB is a template to capture Context parameter configuration requirements to describe the experiment execution environment and its conditions, e.g. in terms of background traffic, emulated network delays, etc. A CB includes information of specific components/elements that are part of the experiment topology, e.g. sources and sinks for traffic generation or emulators of mobile clients. As for VSBs, the CBs includes a wide range of variable parameters that experimenters can set to configure different deployments of the same experiment. Several compatible CBs can be defined for each VSB. CBs are stored in 5G EVE Portal catalogue and can be accessed through 5G EVE Portal.

For instance, examples of CBs are: "CB1 - Test background traffic" or "CB2 - Test delay", and examples of configurable parameter for CB1 are: "N° of AGVs", "Location", "N° of emulated AGVs" or "Number of traffic generators".⁵

It should be noted that the entire definition of the experiment is always based on the inputs provided by the *Vertical* in initial design step, combined with the expertise of the *Experiment developer* in the modelling of experiment environments and testing execution.

When building the Experiment Blueprint (ExpB)⁶, the *Experiment developer* can select the combination of a VSB plus multiple CBs. An Experiment Blueprint (ExpB) is therefore, a combination of a VSB plus one or multiple CBs.

⁴ Note: [Annex A.3](#) includes an example of a VSB.

⁵ Note: [Annex A.4](#) includes an example of a CB for a simple traffic generator.

⁶ Note: [Annex A.5](#) includes an example of an ExpB.

Next, the *Experiment developer* creates the Test Cases Blueprint (TCB)⁷, reported associated to the ExpB to be defined. The TCB includes the set of scripts to launch during the experiment execution. As for the other blueprints, the TCB includes several variable parameters. Some of them can be directly provided by the experimenter when configuring the experiment settings. Others are computed automatically by the platform based on the configuration values provided for CBs or VSBs.

As part of the ExpB definition, the *Experiment developer* also defines the Network Service Descriptor (NSD)⁸ associated to the experiment and corresponding to the deployment of its entire environment, i.e. including both the components of the vertical service (from the VSB) and the ones from the execution context (from the CBs).

NSD is a deployment template that consists of information used by the NFV Orchestrator (NFVO) for life-cycle management of a Network Service (NS). An NS is a composition of Network Functions (NF) that may be interconnected through virtual link and/or with traffic flows regulated according to one or more forwarding graphs.

The *Experiment developer* defines in the 5G EVE Portal, along with VSB, CB, TCB, and ExpB, the "translation rules" that allow the 5G EVE Portal back-end to automatically map an ExpB (service-oriented from the verticals) to one or more NS instances (formal definition of the vertical service and experiment settings that will run in the 5G EVE facilities to execute the experiment).

The NSD includes or references the descriptors of its constituent objects: Virtualized Network Function Descriptors (VNFD), Physical Network Function Descriptors (PNFD) [Used by NFVO to determine how to connect PNFs to Virtual Links (VL)s. The information contained within PNFD is limited to the description of the connectivity requirements to integrate PNFs in an NS], Virtual Link Descriptors (VLD) [used by the NFVO to deploy VLs], VNF Forwarding Graph Descriptors (VNFFGD) [describes a topology of the NS or a portion of the NS, by reference to a pool of connection points and service access points, the descriptors of its constituent VNFs, PNFs and of the VLs that connect them].

NSDs, VNFDs and PNFDs available are stored in I/W Framework multi-site catalogue and can be accessed through 5G EVE Portal. The I/W Framework catalogue is responsible for maintaining the synchronization between the centralized view of the descriptors available in the multi-site I/W Framework and the local repositories in each 5G EVE site.

NSDs and VNFDs/PNFDs onboarded in the 5G EVE Portal follows the ETSI NFV-IFA 014 [13] ETSI NFV-IFA 011 [14] specifications respectively. They are internally translated in the ETSI NFV-SOL 001 [9] format when they are stored in the I/W Framework catalogue.

NFV-SOL 001 defines a mapping of information elements in NFV-IFA 011 and NFV-IFA 014 to data types of TOSCA Simple Profile in YAML. YAML files are provided to be imported into TOSCA processors and used to write custom NSD, VNFD, etc. Finally, to on-board an NSD on the network orchestrators, the YAML files must be packaged with a proper format. NFV-SOL 007 [15] and NFV-SOL 004 [16] describe the NSD package and the VNF package, respectively.

Experiment Design Tools will provide visibility of blueprints (VSB, CB, TCB, ExpB), NSD, VNF and PNF available in the platform. These tools are available in M16 (Oct-2019) thru Open Interfaces and in M18 (Dec-2019) through 5G EVE Web Portal.

⁷ Note: [Annex A.6](#) includes an example of an TCB.

⁸ Note: [Annex A.8](#) includes an example of an NSD.

2.1.2 5G Experiment Flow – Experiment Preparation

In this phase, the experiment environment is properly prepared and configured to enable the experiment execution in a given timeslot and for a given configuration. Figure 5 highlights in yellow the main Experiment Preparation activities.

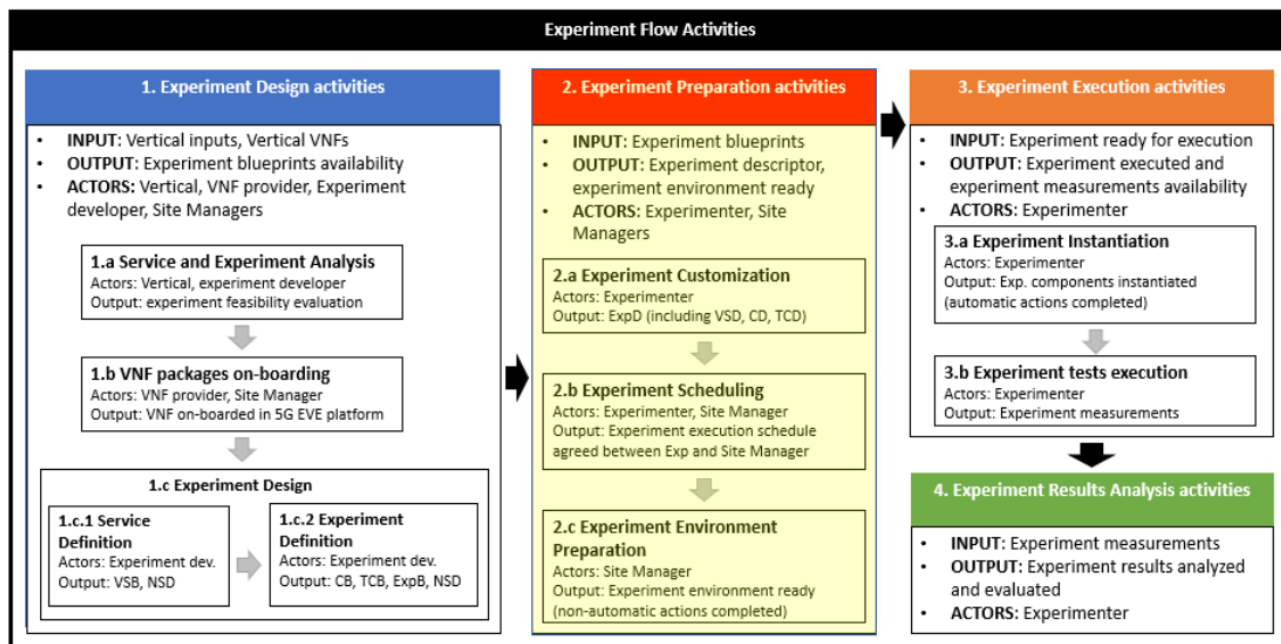

Figure 5: 5G EVE Experiment Flow - Experiment Preparation Activities

This activity involves the *Experimenter* and the *Site manager* of the target sites. This phase includes three major steps, as follows:

- **Experiment customization:** the *Experimenter* configures the experiment, filling in the missing information of the variable parameters defined in the VSB, CBs and TCBs included in the selected ExpB. The result of this customization produces an Experiment Descriptor (ExpD)⁹, composed by the related VSD, CDs and TCDs, which embeds all the information needed to instantiate and run the experiment itself. The 5G EVE Portal GUI offers a wizard that guides the experimenter in the definition of the ExpD, indicating all the parameters to be configured according to the blueprints. When the ExpD is completed, it is onboarded in the Portal Catalogue and it becomes available through the 5G EVE Portal.
- **Experiment Scheduling:** In this activity, the *Experimenter* requests to book the resources for running the desired experiment and provides the tentative day/site(s), together with the experiment description in the ExpD previously specified. One of the Run Experiment Tools, the Experiment Lifecycle Manager, creates a new entry for the experiment instance and automatically generates a ticket, which is used as a reference for the interaction between the *Experimenter* and the Site Manager to agree on the experiment execution day. This interaction is done through the Ticketing system tool. *Site manager* will receive this ticket and will evaluate the availability of the infrastructure in the proposed time slot. The Ticketing system tool is used to mediate the interaction between *Experimenter* and site owner until they reach an agreement for a suitable date/time. Ticketing system tool is available in M16 (Oct-2019) thru Open Interfaces and in M18 (Dec-2019) through 5G EVE Web Portal.
- **Experiment Environment Preparation:** In this activity, upon the site manager’s approval of the experiment request ticket, the *Site manager* secures all non-automatic 5G EVE platform system changes needed (for instance, the creation/development of TC scripts to run the TCs (in case they cannot be built

⁹ Note: [Annex A.7](#) includes an example of an ExpD.

automatically by the system), the provisioning of SIMs in the database, PNF configuration,...) for the experiment execution are prepared.

2.1.3 5G Experiment Flow – Experiment Execution

In this phase, the dedicated virtual environment to run the experiment (and associated test cases) is built, and finally the experiment TCs are executed. Figure 6 highlights in yellow the main Experiment Execution activities.

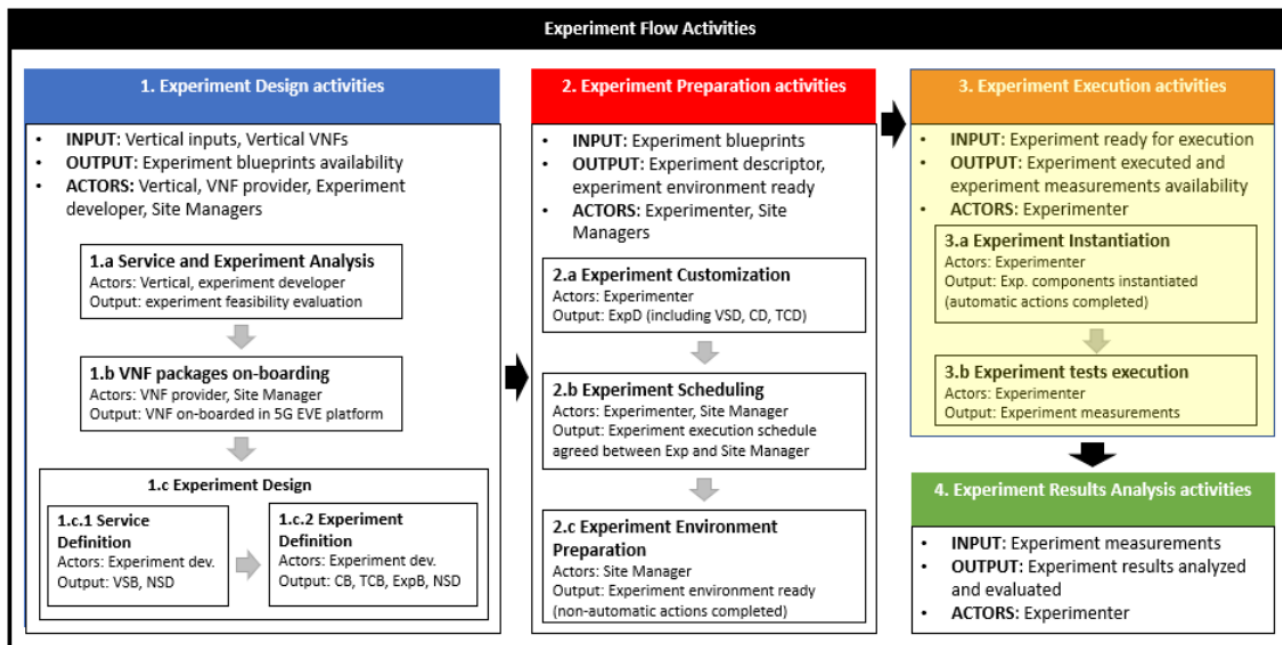

Figure 6: 5G EVE Experiment Flow - Experiment Execution Activities

This phase is triggered by the *Experimenter* through the 5G EVE Portal and is fully automated within the 5G EVE platform, involving the interaction between the portal, the I/W Framework and local orchestrators and testing tools available at the target site. The experiment execution phase includes two steps, as follows:

- **Experiment instantiation:** the Experiment Lifecycle Manager at the 5G EVE Portal interacts with the I/W Framework to request the creation of the Network Slice/s associated to ExpD and so, instantiating the network services based on the requirements defined in ExpD.

ETSI GS NFV-SOL 005 [17] will be used for Os-Ma-nfvo Reference Point between I/W Framework and local Orchestrators for the instance of the Network Slices associated to the ExpD / NSD. A Network Slice in 5G system refers to a complete E2E logical network (i.e. including both Access and Core networks) providing telecommunication services and network capabilities. Network slicing enables the network operator to deploy multiple, independent PLMNs where each is customized by instantiating only the features, capabilities and services required to satisfy the subset of the served users/UEs or a related business customer need. Multiple instances of the same Network Slice (Network Slice Instances (NSIs)) may be deployed over virtual and physical infrastructures, e.g. by the same operator willing to provide separately the same telecommunication service to different groups of users. For further information of Network slicing and implementation in 5G EVE platform, please refer to section 3.2.1.

- **Experiment tests execution:** *Experimenter* executes the TCs associated to the experiment. Using Experiment Monitoring tools, first, *Experimenter* does the checks to ensure the experiment KPIs can be monitored (prepare experiment monitoring Framework by checking that charts, tables, time/object granularity and ensures KPIs needed to monitor the Experiment execution can be selected in the tools) and Experiment Results can be collected. After checks have been successfully completed, *Experimenter* runs the experiment and its associated TCs, monitors Experiment Execution and collects Experiment

metrics, KPIs and results. Data visualization tool was available from M16 (Oct-2019) thru Open Interfaces and in M18 (Dec-2019) also through 5G EVE Web Portal.

2.1.4 5G Experiment Flow – Experiment Result Analysis

In this phase, the *Experimenter* analyze the experiment / TCs test cases results. Figure 7 highlights in yellow the main Experiment Result Analysis activities.

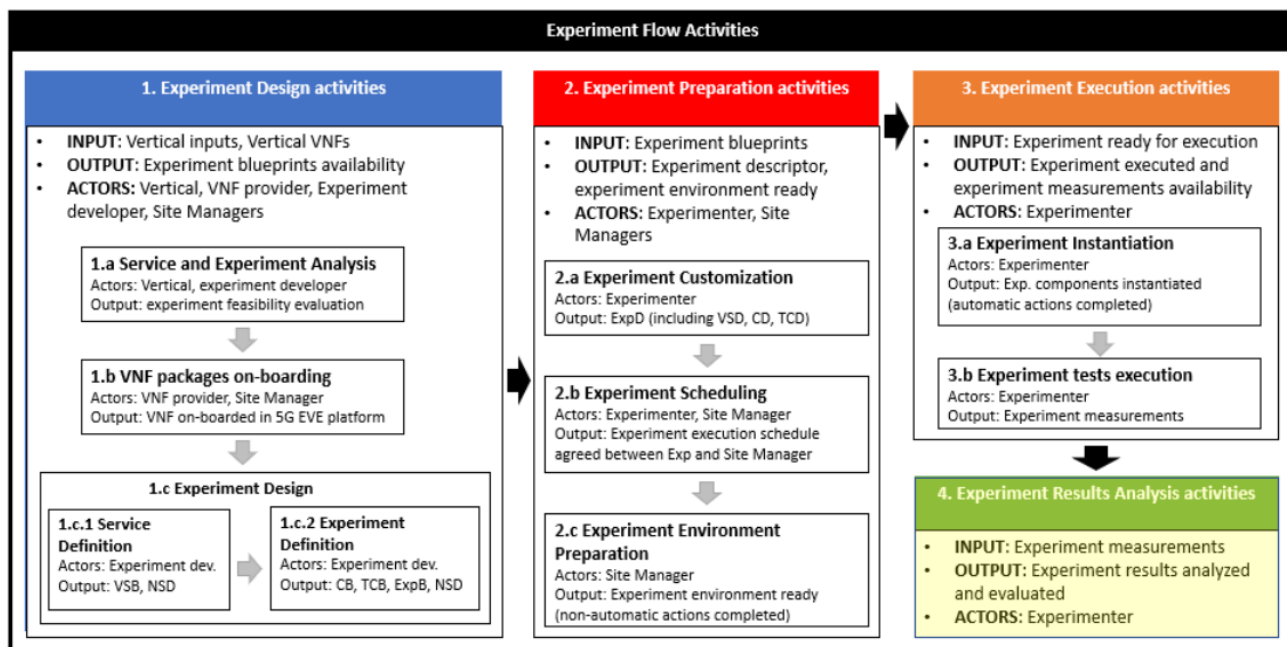

Figure 7: 5G EVE Experiment Flow - Experiment Result Analysis Activities

After the experiment / TCs execution, for the KPIs the targets defined are not achieved, a performance diagnosis report is produced by 5G EVE platform including information of potential bottlenecks of degradation and potential solutions using post-process analytics on the collected KPIs. This report helps *Vertical* to characterize their use cases in selected scenarios. Performance diagnosis report will be available in 5G EVE platform from M24 (June 2020).¹⁰

2.2 5G Experiment Flow Example

During Experiment design phase, two templates are used: first, the “Experiment Template” to be filled by *Vertical* and, then, the “Low Level Test Plan Template” to be filled by the *Experiment Developer*.

A section of the “Experiment Template” filled by ASTI, one of the Verticals involved in the 5G EVE project, is shown next for the Experiment shown in Figure 8, whereas the complete template and the example filled by ASTI are detailed in D5.1 [18].

Experiment Description:

The experiment will test the virtualization of the control algorithms of AGVs (Autonomous Guided Vehicles). In the current state of the art the AGVs have a PLC in charge of governing the internal control loop, what is collecting the information of the guiding sensors, taking the appropriate control decisions and generating the necessary signals to regulate the speed of the motors. During the experiment this internal control loop will be relocated out of the AGV thanks to the 5G communication technologies.

¹⁰ Note: D5.1 [18] covers a full description of Testing Framework within 5G EVE.

Expected Capabilities:

A high performance and reliable mobile network connecting the AGVs to the platform with the virtual machines is required. The most challenging requirements to ensure the deployment of the solution in the future factories are the high reliability and the low latency and jitter.

Experiment architecture:

The AGV will have a Slave PLC on board. This PLC will collect the information from the sensors and physical inputs, this will be sent to the Virtual PLC. The Virtual PLC will process all this information, then it will take the appropriate control decisions and it will generate the right signals to control the motors of the AGV. This control signals will be sent by 5G communication network to the Slave PLC, which will process them translating to real physical signals to command the motors.

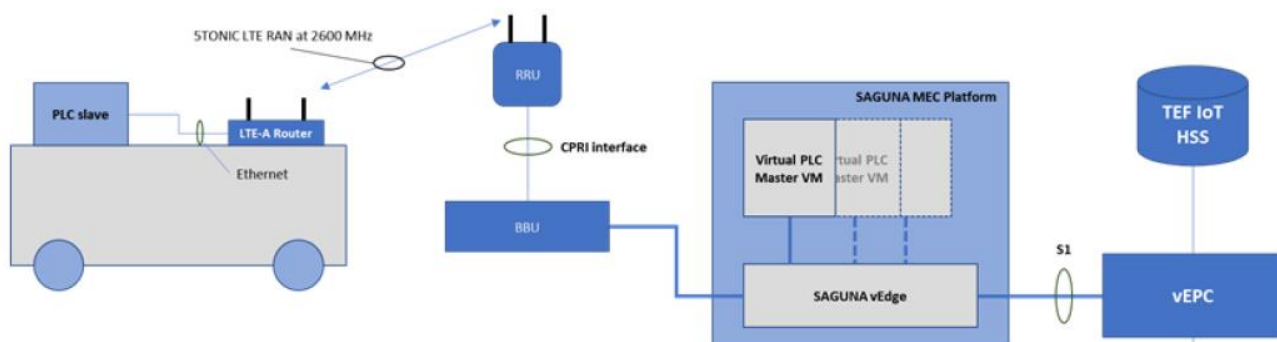

Figure 8: Example of "Experiment Template" filled by ASTI

Following next, an example of part of a “Low-Level Test Plan Template”, including table template in Figure 9 is depicted.

TO BE FILLED BY THE 5G-EVE CONSORTIUM. INSTRUCTIONS:

- There should be (ideally one and only) one test case for each high-level KPI which is meaningful for the Vertical running the experiment.
- If derived from the external conditions, the “expected results” change, then this can be reflected in different Test Sub-cases. Ideally, the Test Objective, Prerequisites, and Required Capabilities will be common, while the rest of the fields will be completed on a per sub-case basis.
- The fields on each Test Case are:
 - Test Objective, to be derived mainly from “Target KPI” in Vertical Test Plan
 - Test Prerequisites, to be derived mainly from “Experiment Description” and/or “Measurement Method” in Vertical Test Plan. This reflects if any initial conditions are to be met before launching the test
 - Required Capabilities, to be derived mainly from “Experiment Description” and/or “Measurement Method” in Vertical Test Plan. This reflects the requirements imposed to the potential hosting sites, to make sure they can support the experiment.
- The fields associated with each Test Sub-case are:
 - Test Topology, to be derived mainly from “Experiment Description”
 - Test Variables, to be derived mainly from “Parameters” in Vertical Test Plan
 - Test Procedure, to be derived mainly from “Experiment Description” and “Measurement Method” in Vertical Test Plan
 - Expected Results, to be derived mainly from “Expected Results” in Vertical Test Plan

Test Case 1	
Test Name:	
Test Objective:	
Test Prerequisites:	
Required Capabilities:	
Sub-Case 1	Test Topology:
	Test Variables:
	Test Procedure:
	Expected results:
Sub-Case 2	Test Topology:
	Test Variables:
	Test Procedure:
	Expected results:

Figure 9: Example of "Low Level Test Plan Template"

Finally, with this information, the blueprints described in this section are created. Templates examples for them can be found in the annexes of this document.

The blueprints include a wide range of variable parameters that *Experimenter* will fill-in with missing information during the Experiment Customization phase to create the associated descriptors, finally ending up in an ExpD generated to be run during the execution phase.

In Table 2, an example of VSD parameters (for more information, refer to D4.1 [6]) is shown, while an Experiment Descriptor example is shown in Table 3 (for more information, refer to D4.1 [6]).

Table 2: Example of Description of Vertical Service Blueprint

Field	Description	Example
blueprintId	Unique Identifier for the VSB.	VSB_ASTI
version	A version number.	0.1
name	Name of the VSB.	AstiAGVControl
description	Short description of the VSB.	Asti AGV control service
parameters	List of parameters. The list provides for each parameter its name, type, description, and the field of applicability	Sensor_amount, number of guiding sensors, efactory...
atomicComponents	List of atomic functional components (i.e., network functions and virtual applications in general) needed to implement the VSB.	masterPLC, Server number 3, componentId EPC, Server number 1...
endPoints	Specification of connection endpoints. They can be internal or external.	endpoint Id = agv_sap_data, mpls_data_ext...
connectivityServices	List of virtual links and their relevant end points. Virtual links describe how the atomic functional components are connected.	endPointIds": "agv_sa_data", "mpls_data_ext", "pEPC_data...
serviceSequence	Description of how traffic flows among VNFs, supporting also multicast scenarios.	hopEndPoints...

Table 3: Description of Experiment Descriptor

Field	Description
expDescriptorId	Unique Identifier for the ExpD.
version	A version number.
name	Name of the ExpD.
description	Short description of the ExpD.
expBlueprintId	The identifier of the ExpB this experiment descriptor was built from.
vsDescriptorId	ID of the <i>Vertical Service Descriptor</i> describing the vertical service to be deployed to run this experiment. It provides the full specification of the parameters related to the vertical service, as defined in its originating blueprint.
ctxDescriptorIds	List of the IDs of the components associated with the experiment execution contexts (i.e. the Context Descriptors) to be deployed to run this experiment. They provide the full specification of the parameters related to the contexts, as defined in their originating blueprints.
testCaseDescriptorIds	List of the IDs of the test case descriptors defining the steps to run this experiment. They provide the full specification of the values of the variable parameters to be added in the experiment scripts, as defined in their originating blueprints.
kpiThresholds	List of thresholds for the KPIs defined in the originating experiment blueprint. They define the criteria to evaluate the results of the experiment.

Once the preparation phase is completed, *Experimenter* runs the experiment. *Vertical* KPIs will be monitored along with experiment execution. To give an example of how network KPIs can be used to assess *Vertical* Application performance and use case execution, we will use the same ASTI Automated Guided Vehicle (AGV) example used so far:

- One of the *Vertical* High Level KPI identified by a *Vertical* is the network **Jitter**.

Jitter is a term used to refer to the variation in latency of packet flow. In “Use case 3 - Industry 4.0: Autonomous vehicles in manufacturing environments” described in D1.1 [3], the target value is to make it less than 5ms. For the right functioning of the AGV, it is important that the movement is smooth, and jitter can be used to evaluate that.

One of the Network KPIs that could be measured is Reliability, which is the probability of success of transmitting a packet within a required maximum time. This KPI can be used by the *Vertical* to evaluate fluctuations in the Latency and thus, the Jitter. The lower the Reliability, the higher the probability of having fluctuations in the latency and hence, to not getting a smooth AGV movement.

Reliability could be used to evaluate Jitter and then, the *Vertical* KPI metric of navigation level to assess the quality of the AGV navigation.

This is an example of a *Vertical* KPI where a relationship exists with Network KPIs and so, a Network KPI can be used to evaluate a *Vertical* KPI.

- Another *Vertical* High Level KPI identified by the *Vertical* is the network **Latency**.

In “Use case 3 - Industry 4.0: Autonomous vehicles in manufacturing environments” described in D1.1 [3], the target value is to achieve less than 10ms.

High Latency could affect the efficiency of the navigation. Movement Control commands arriving late to local AGV controller will make AGV to move in the wrong direction. Continuous corrections in trajectory could severely reduce the efficiency of the AGV (for instance, by increasing battery consumption). Latency can be directly measured in the network using different applications. For instance, an application deployed as a VNF close to AGV remote controller could be used, sending pings to local AGV and measuring RTT or an application running in the AGV management system, and getting latency information from information received from AGV local sensors and ACK (acknowledge) received from them, etc.

This is an example of a direct mapping between a *Vertical* KPI and a Network KPI.

- Finally, another High Level *Vertical* KPI identified by a *Vertical* could be the **power consumption** of the AGV. This is an example of a *Vertical* KPI where network KPIs cannot be used for its evaluation. In this case, the *Vertical* should provide some means to ensure 5G EVE KPI measurement and evaluation system and tools are able to collect the values of such measurements along the experiment execution.

As described in this section, 5G EVE platform offers tools that facilitate the *Experimenter* to monitor in real-time the metrics defined in the experiment. 5G EVE tools deployed in the 5G EVE portal will extract the experiment results, metrics and KPIs generated for a given experiment from a specific publish-subscribe queue which is directly connected to the I/W Framework publish-subscribe queue provided by the Data Collection Manager component at the I/W Framework. These results will be presented to the *Experimenter* through an intuitive GUI of a data visualization tool available in the same portal. This tool will be interactive, allowing *Experimenter* to select what information is displayed, to set thresholds in the visualization charts, etc.

Figure 10 shows an example of information that can be visualized in the 5G EVE portal GUI after and during experiment execution. In this example, measurements are collected during the execution of use case described in section 3.1 of deliverable D1.1 [3], and section 3.1.1 in deliverable D2.1 [7]. The focus of this use case is the integration of 5G data and mobility data from different transport operators to enhance sustainable multi-modality between railway network and other urban transportation services, in an “Urban mobility” scenario. *Experimenter* can use 5G EVE portal GUI data visualization tool to visualize KPIs in several formats. In this

3 5G EVE platform – 5G Key enablers and 5G Capabilities

3.1 5G EVE platform –5G Capabilities

International Telecommunication Union (ITU) commits to facilitate international connectivity in communications networks for which it is key to develop the technical standards that ensure networks and technologies to be seamlessly interconnected. Within International Telecommunication Union - Radiocommunication (ITU-R) recommendation M.2083-0 [19], ITU defines the Framework and overall objectives of the future development of International Mobile Telecommunications (IMT) for 2020 and beyond to better serve the needs of the networked society. Within this Framework, and based on observed trends, the vision for IMT for 2020 and beyond is established.

IMT systems serve as a communication tool for people and as a facilitator which assists the development of other industry sectors, such as medical science, transportation, education and much more. Considering the key trends analyzed, IMT for 2020 and beyond, is envisaged to expand and support diverse usage scenarios and applications.

IMT is the ITU name for a family of technologies and IMT-2020 is the ITU name for 5G corresponding in the ITU environment to the systems beyond IMT-Advance (4G). Mobile service generations are depicted in Figure 11.

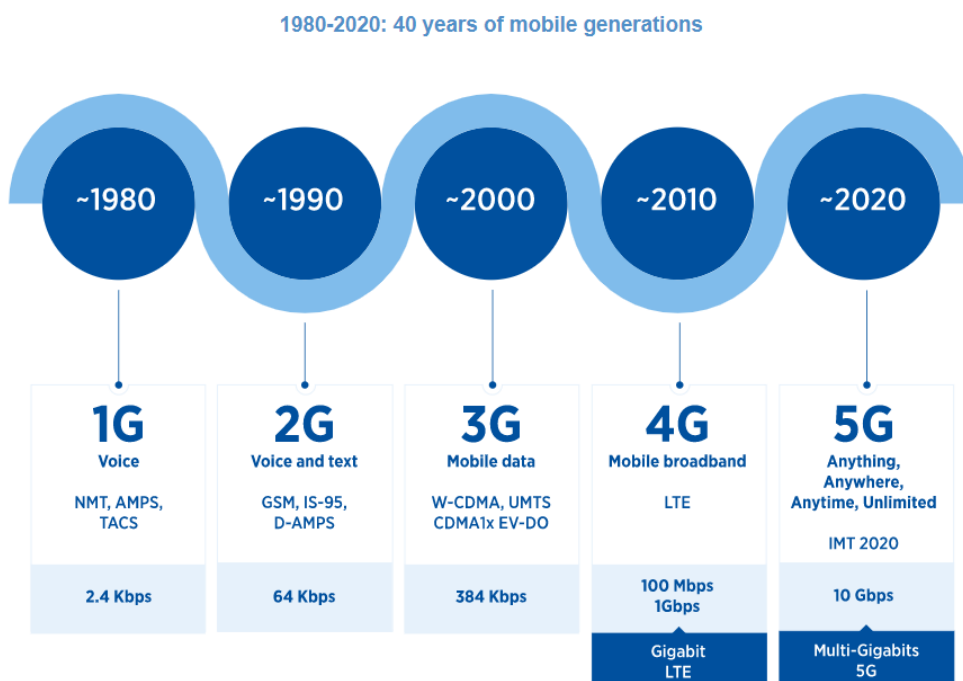

Figure 11: Mobile service generations

Furthermore, a broad variety of capabilities and performance requirements would be tightly coupled with these intended different usage scenarios and applications of IMT for 2020 and beyond. The usage scenarios of IMT for 2020 and beyond, presented in Figure 12, include:

- Enhanced Mobile Broadband (eMBB): with “human-centric use cases for access to multi-media content, services, and data”.
- Ultra-reliable and low latency communications (URLLC): with “stringent requirements for capabilities such as throughput, latency and availability”
- Massive machine-type communications (mMTC), with the specificity to address “a very large number of connected devices typically transmitting a relatively low volume of non-delay sensitive data”, with low cost and long battery life devices.

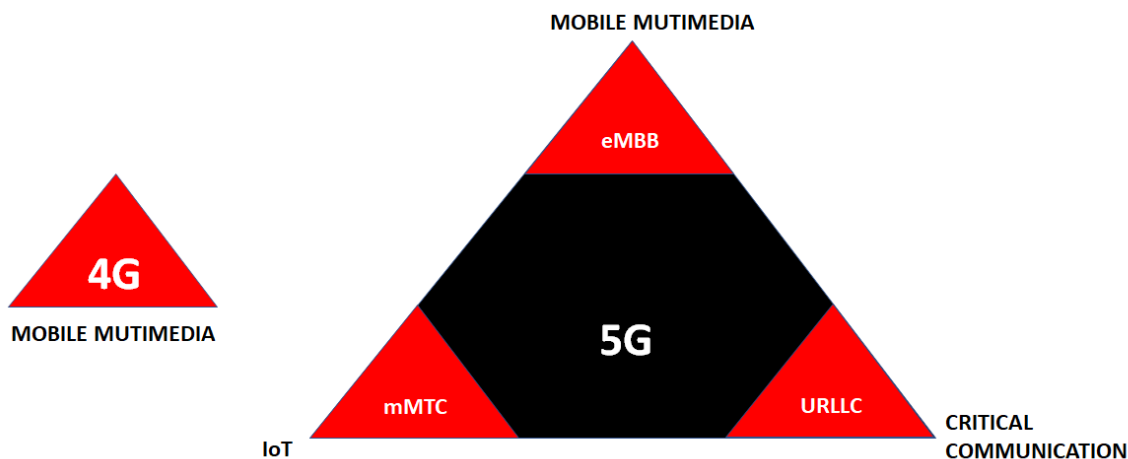

Figure 12: IMT 2020 eMBB, URLLC and mMTC usage scenarios

The first 5G release was Rel-15 which included 5G New Radio (NR) specification. Rel-15 is most focused on eMBB services, but it sets the foundation for URLLC and mMTC as well. The first release of a full complete set of 5G system standards specifications (Rel-16) is expected to be released on early 2020.

A set of eight Key Capabilities for IMT-2020 have been defined in ITU-R M.2083 [19] and fully described in ITU-R M.2410-0 [20] Latency, Speed, Reliability, Availability, Mobility, Broadband Connectivity, Capacity and Device Density.

Deliverable D1.1 [3] included the description of first six use cases selected for different Verticals to be validated in 5G EVE platform:

- Smart Transport: Intelligent railway for smart mobility.
- Smart Tourism: Augmented Faire experience.
- Industry 4.0: Autonomous vehicles in manufacturing environments.
- Utilities (Smart Energy): Fault management for distributed electricity generation in smart grids.
- Smart cities: Safety and Environment - Smart Turin.
- Media & Entertainment: UHF Media, On-site Live Event Experience and Immersive and Integrated Media).

For each of them, vertical’s use case requirements for this set of Key capabilities are represented in a unique radar on top of 4G and 5G expected values. This radar is later used to framework the vertical use cases into one of the 5G usage scenarios as shown in Table 4.

Table 4: 5G EVE use cases and requirements mapping

Requirements	Smart Transport	Smart Tourism	Industry 4.0	Utilities (Smart Energy)	Smart cities	Media & Entertainment
URLLC	X	X	X	X	X	X
eMBB		X				X
mMTC	X			X	X	X

An example of this mapping for “Use Case 5a - Smart cities: Safety and Environment - Smart Turin” is shown in Figure 13 below.

5G-EVE: 4G/5G capabilities and Use Case 5a Smart Cities Requirements
 Safety and Environment - Smart Turin - Comune Di Torino - Italy

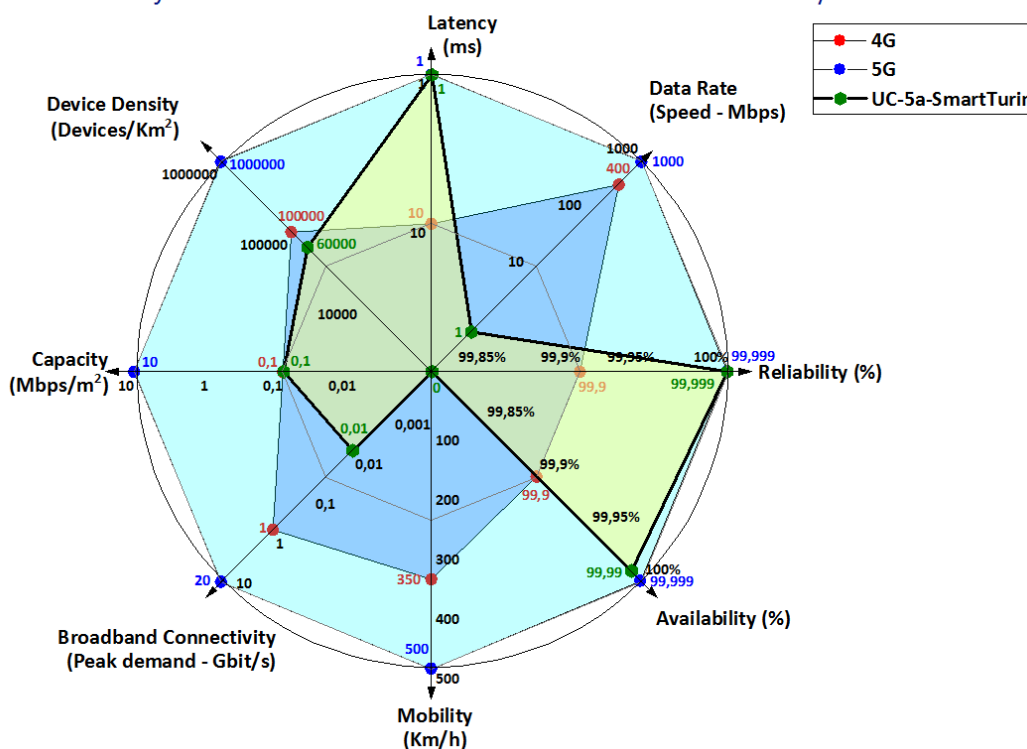

Figure 13: Mapping of Use Case 5a, 4G and 5G performance requirements

It is important to emphasize that all this eight 5G capabilities / performance requirements are not expected to be achieved from the very beginning in 5G EVE platform since, among other factors, these targets have been set for Rel-16 [21] version (First Rel-16 specification is expected to be released on early 2020) of 5G networks, while 5G EVE deployment will be started with Rel-15 version of implementation and will evolve in time till finally Rel-16 version is deployed.

Table 5 shows the expected availability of the key capabilities identified by 5G EVE Vertical's Use Case Requirements:

Table 5: 5G Key Capabilities availability in 5G EVE

Vertical Key Capability (D1.1)	ITU-R M.2083 Capability	Availability
Speed	<ul style="list-style-type: none"> DL User Experienced Data Rate (Mbps): 100 Mbps UL User Experienced Data Rate (Mbps): 50 Mbps 	2019/MAY
Broadband Connectivity	<ul style="list-style-type: none"> DL Peak Data Rate (Gbps): 20 Gbps UL Peak Data Rate (Gbps): 10 Gbps 	2021/JAN ^{13 14}

¹³ Note: First release of 5G EVE platform based on with 3GPP Rel-16 [16] is planned for January 2021.

¹⁴ Note: It is expected that some 5G EVE sites have 400 MHz bandwidth available in N258 band from January 2021 for NR.

Vertical Key Capability (D1.1)	ITU-R M.2083 Capability	Availability
Capacity	Area Traffic Capacity (Mbit/s/m ²): 10 Mbit/s/m ²	2021/JAN ¹³
Latency	<ul style="list-style-type: none"> UP Latency (ms): 1ms (URLLC), 4 ms (eMBB) CP Latency (ms): <20 ms 	<ul style="list-style-type: none"> UP Latency: 2019/MAY for eMBB and 2021/JAN for URLLC^{13 14} CP Latency: 2021/JAN for URLLC
Device Density	Connection Density: 1 M devices/km ² (mMTC)	2021/JAN ¹³
Mobility	<ul style="list-style-type: none"> Stationary: 0 km/h Pedestrian: 0 km/h to 10 km/h Vehicular: 10 km/h to 120 km/h High-speed vehicular: 120 km/h to 500 km/h 	<ul style="list-style-type: none"> Stationary and Pedestrian (2019/MAY) Vehicular and High Speed Vehicular (2021/JAN)¹³
Reliability	1-10 ⁻⁵	2021/JAN for URLLC ^{13 14}
Availability	NA	NA

A general assumption that apply to availability column values in Table 5 is that UEs/Devices and Vendor Network equipment support required capabilities. Additionally, the analysis of the ICT-18/19/22-5G Infrastructure PPP Phase 3 [2] projects of which may be hosted by 5G EVE project is in progress. The use cases have been identified for the different projects, as shown in Table 6 below.

Table 6: ICT-18/19 Projects – Vertical's/Use Cases

ICT-18/19 Projects	Factories	Agro-Food	Automotive	Transport and Logistics	Smart Cities and utilities	Energy	Health and Wellness	Media and Entertainment
5G EVE	X			X	X	X		X
5G Drive			X					
5GCroCo			X					
5G CARMEN			X					
5G-MOBIX			X					
5G Solutions	X				X	X		X
5G TOURS							X	X
5G!Drones				X	X			X
5G HEART		X		X			X	
5G GROWTH	X			X		X		
5G VICTORI				X		X		X

3.2 5G EVE platform – 5G Key enablers

Some technologies are identified as key enablers to achieve 5G capabilities and provide expected performance. The next sections give a brief description of each of them and describe how they are planned to be integrated into 5G EVE platform.

3.2.1 Network Slicing

One of the 5G Key technology enablers which has to be considered as a Service Capability for 5G EVE Platform is Network Slicing. Within 5G EVE perspective (ref D3.1 [22]), Network Slicing is described as a mean “*to satisfy the demand of dedicated telco services with specific Service Level Agreements (SLA)*”. From 5G EVE perspective, this is a way to ensure Use case performance requirements described by the *Vertical* can be fulfilled using 5G EVE platform.

The service could be described as “Network Slice as-a-service” which provides a concrete answer to *Vertical*’s demand by enabling “à la carte” End-to-End services. In this model, a Network Slice is offered by a Communication Service Provider (CSP) to a Communication Service Customer (CSC) for a communication service that is based on a Network Slice Instance. In 5G EVE model, the Site Manager would be the CSP and the *Vertical/Experimenter* would be the CSC.

The meaning of Network Slicing and its concept varies as different definitions can be found in different SDO documentation and there is no consensus among all for a common definition.

The concept of Network Slicing has been defined as a key feature for 5G by 3GPP TS 28.530 [23]. It has been defined by ITU-T Y.3100 Recommendation [24] and 3GPP TS 23.501 [25] as “*a logical network that provides specific network capabilities and network characteristics*” with following interesting notes for ITU:

- “*NOTE 1 – Network slices enable the creation of customized networks to provide flexible solutions for different market scenarios which have diverse requirements, with respect to functionalities, performance and resource allocation.*”
- *NOTE 2 – A network slice may have the ability to expose its capabilities.*
- *NOTE 3 – The behavior of a network slice is realized via network slice instance(s) (NSI)”*

In this context, a Network Slice Instance (NSI) is a set of network functions and the resources for these network functions which are arranged and configured, forming a complete logical network to meet certain network characteristics.

Considering that 5G EVE ambition is to build a 5G end-to-end facility which operates end-to-end Network Slices and 5G services across multiple administrative domains, Network Slice “logical network” within 5G EVE platform will include 5G system network functions (consisting of 5G Access Network (AN), 5G Core Network and UE), but also additional network functions needed to fulfil the SLA of the service within this logical network, like for instance, the transport network that is used to interconnect 5G system network functions, either within a site or between different sites.

3GPP TR 28.801 [26] introduces a model where a Network Slice (see Figure 14) is composed of one or many Network Slice Subnets and so, addressing the ability to deploy and manage a Network Slice Instance built on Network Slice Subnet Instances from multiple Network Operators.

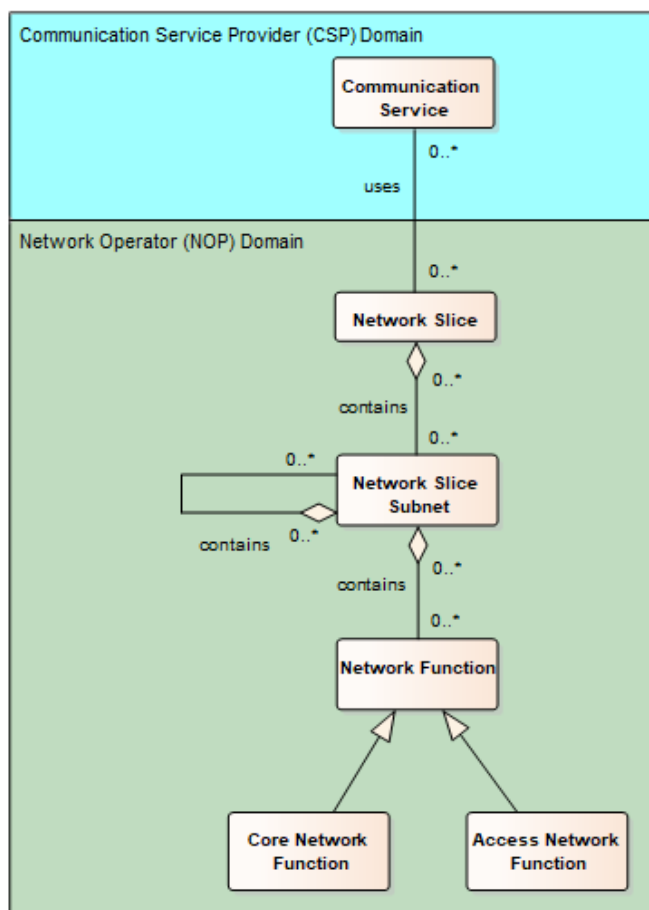

Figure 14: Network Slice related information model in 3GPP TR 28.801 [25]

In this context, a Network Slice subnet instance is then a set of network functions and the resources for these network functions which are arranged and configured to form a logical network.

Within 5G EVE, NSD can be mapped to a Network Slice and, in case network functions included in NSD expand more than one site, each group of network functions and associated resources belonging to each site can be mapped to a Network Slice subnet instance (NSSI) (as shown in Figure 15), which all connected make the NSI corresponding to NSD defined for the experiment and the network service (NS) that wants to be provided.

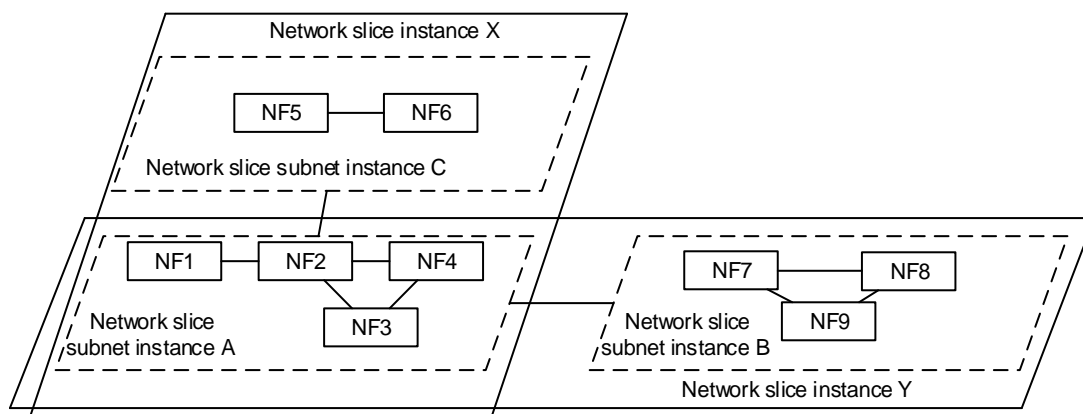

Figure 15: NSI X and Y composed by NSSI A, B and C [25]

As described in section 2 during the experiment design phase, performance requirements (mapped to SLA concept of network slicing description above) required by the experiment are identified and they materialized into an associated NSD which includes a list of NFs and an identification of how they are connected through virtual link and/or with traffic flows regulated according to one or more forwarding graphs are created.

During the Experiment Preparation phase, Site Manager secures that PNFs described in the NSD are configured and that transport network requirements specified in the NSD for the interconnection of the NFs belonging to the site he/she manages, are fulfilled as well.

In order to secure the fulfillment of Network Slice SLAs requirements in the transport network, the initial approach to face this challenge in 5G EVE is by mapping slices instances to transport Virtual Private Network VPNs (L2 or L3 VPN).

This concept secures traffic isolation among slices but also allows to map QoS requirements of the Network Slice in the transport by using Differentiated Services Code Point (DSCP) [L3 field in IP header] or Class of Service (CoS) [L2 field in Data Link Layer]. Additionally, since experiments could expand to more than one site, and so, include NFs located in different sites, in order to secure Interworking connectivity among sites and enough bandwidth capacity to run the experiments, some interworking connectivity requirements have been identified and will be implemented in 5G EVE platform. The details can be found in section 0.

During the Experiment Execution Phase, the Experiment Lifecycle Manager tool at the 5G EVE Portal interacts with the Multi-site Network Orchestrator (MSNO) in the Interworking Layer to request the instantiation of VNFs of the NSI. In turn, MSNO communicates with the Local Orchestrators of the different sites managing the involved VNFs.

ETSI NFV reference architecture was initiated in order to virtualize network functions and services that were traditionally run on proprietary and dedicated hardware. In ETSI report GR NFV-EVE 012 [27] is described how Network Slicing can be mapped to the ETSI NFV concepts and architectural Framework specified by “Network Functions Virtualization (NFV); Management and Orchestration”.

Figure 16 below gives an overview of the mapping which is the baseline for 5G EVE platform. Three layers are identified in the ETSI NFV Management and Orchestration (MANO) as specified in ETSI GS NFV-MAN 001 [28], each layer providing Application Programming Interface (API)s in order to share resources, network services and Network Slices across multiple administrative domains (i.e. Network Operators or different operation teams inside a Network Operator):

- OSS/BSS (Operations Support Systems/Business Support Systems).
- NFV Orchestrator with VNF Manager.
- Virtual Infrastructure Manager (VIM) for NFV Infrastructure (NFVI) and WAN Infrastructure Manager (WIM) which provides connectivity services between the NFVI.

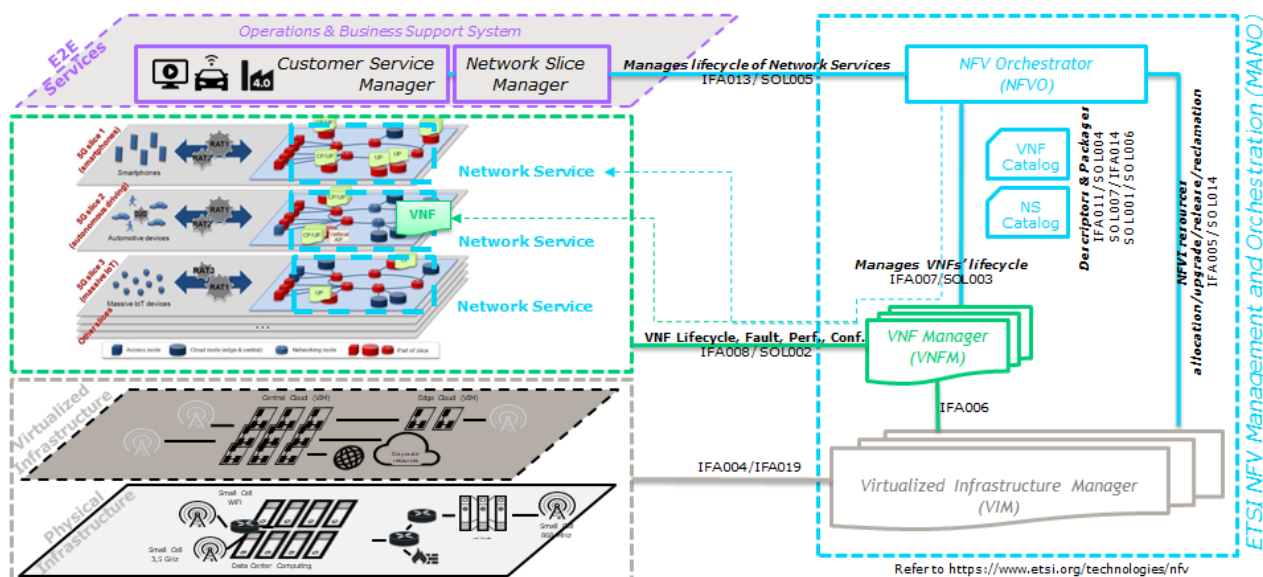

Figure 16: ETSI NFV enablement

In 5G EVE, the OSS/BSS (Operations Support Systems/Business Support Systems) layer is represented by the 5G EVE portal, which stores information of VNF available in different sites through interaction with Multi-site Catalogue of the Interworking Layer. *Experiment Developer* use this information to compose the ExpD and the NSD associated with the experiment.

NFV MANO is responsible for the orchestration and management of the NFVI resources on which it deploys Network Services (NS). For more information about NFV MANO, read section 4.3.

3.2.2 Edge Computing

Edge Computing is generally referred to as a distributed computing paradigm where computation is largely or completely performed on distributed device nodes as opposed to a centralized cloud environment: edge computing pushes applications, data and computing power (services) away from centralized points to the logical extremes (closer to end-user) of a network.

The benefits of this kind of paradigm may be summarized as follows:

- Latency reduction, that is the time needed by data to travel from source device to the place where they are elaborated (today, generally the “cloud”).
- Bandwidth reduction, as the local elaboration of big amounts of data, may provide a significant reduction of data moved over the network. By deploying various services and caching content at the network edge, core networks are alleviated of further congestion and can efficiently serve local purposes.

These benefits make Edge Computing to be an enabler or at least, a key feature to achieve performance requirements for some use cases envisioned in 5G, where very low latencies are required and/or the high increase expected of simultaneous devices sending / receiving data, imposing stringent high capacity requirements in the transport network.

3GPP has identified this in System Architecture specification 3GPP TS 23.501 [25], by addressing different mechanisms to support Edge Computing. As described in this document, Edge computing enables operator and 3rd party services to be hosted close to the UE's access point of attachment and so, to achieve an efficient service delivery through the reduced end-to-end latency and load on the transport network.

Another goal of Edge Computing is to allow the deployment of applications in an environment very much like the modern cloud the developers are familiar with; ideally, they should not face great differences working with a commercial cloud environment and an “Edge” cloud. In this sense, the enabling key is the exposure of services by mean of RESTful (REST) APIs and the availability of virtualization and/or containerization technologies.

Modern mobile networks are already familiar with these concepts, in fact, network deployments are today focusing on NFV technology and different sets of APIs.

The 5G Core Network may expose network information and capabilities to an Edge Computing Application Function (AF). Based on operator deployment, Application Functions considered to be trusted by the operator can be allowed to interact directly with relevant 5G system Network Functions. Application Functions not allowed by the operator to access directly the 5G system Network Functions shall use the external exposure Framework via the Network Exposure Function (NEF) in the 5G system to interact with relevant 5G system Network Functions. The Application Function (AF) interacts with the 3GPP Core Network in order to provide services.

One example is that Applications could influence on traffic routing in some deployment scenarios. An AF, making usage of information exposed by 5G system Network Functions (like User Equipment (UE) location), may send requests to influence Session Management Function (SMF) routing decisions for the traffic of Packet Data Unit (PDU) Session. The AF requests may influence User Plane Function (UPF) (re)selection and allow routing user traffic to a local access to a Data Network (identified by a DNAI). This example is shown in Figure 17.

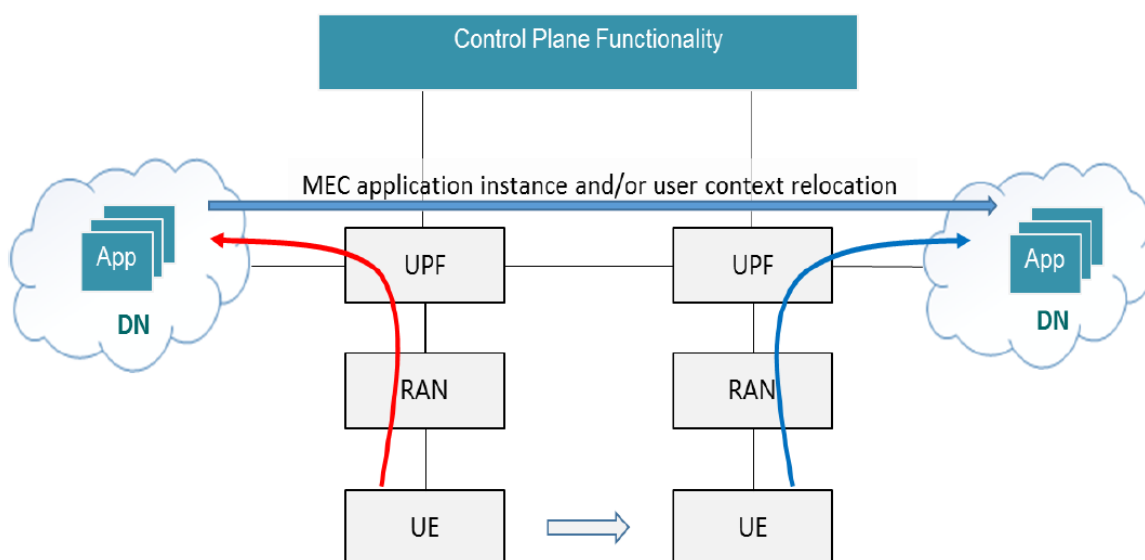

Figure 17: AF re-location in a mobility UE environment

Inside a mobile network, we can distinguish two kinds of topologies regarding Edge exposure:

- Distributed Cloud.
- Multi-access Edge Computing (MEC)¹⁵.

Distributed Cloud approach (see Figure 18) assumes the network components are virtualized and deployed in a distributed fashion: NFV is the main reference. Deploying an Edge Application in this context is the very same of deploying a network component and the set of APIs available and the tools to manage the deployments are the same used by other network applications. This kind of approach can be suitable, for instance, in the

¹⁵ Note: Multi-access simply means that the services provided by an MEC application are largely independent of the access technology adopted.

context of a small number of edge applications strictly controlled and managed by network operator. This approach is being used in 5G EVE platform in some sites to bring user plane network functions closer to the end-user.

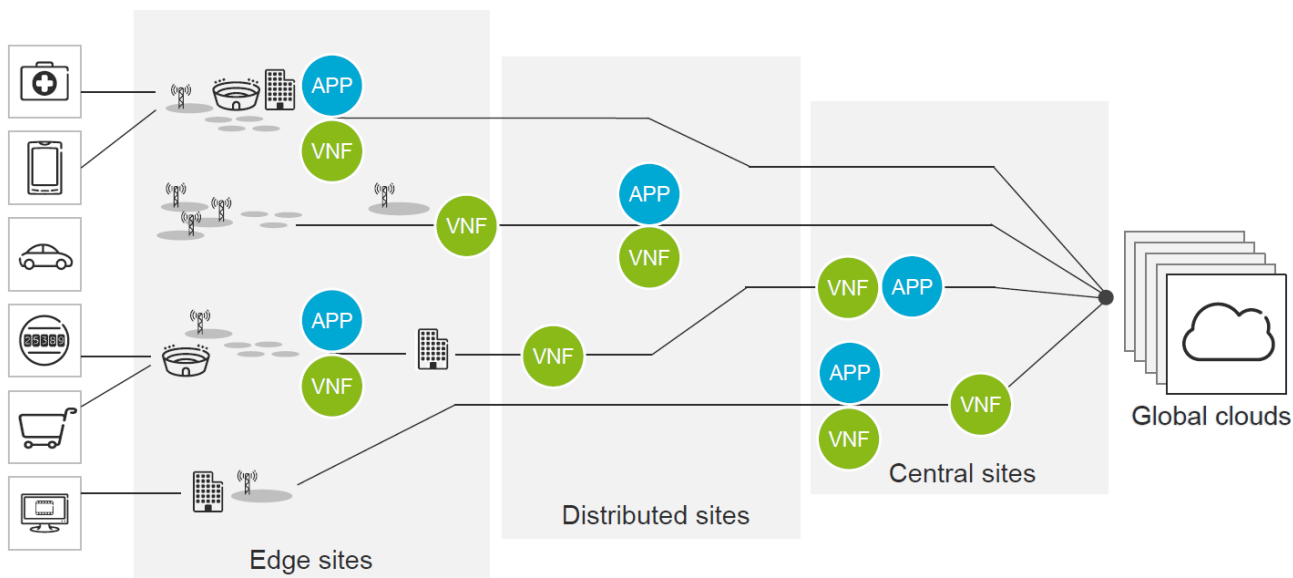

Figure 18: Distributed Cloud [29]

Multi-access Edge Computing (MEC) scenario (see Figure 19) aims to create a platform-independent from the rest of the network exposing its own virtualization or containerization environment, with tools and set of standardized APIs both for services and lifecycle management. Ideally, an application built on this infrastructure can be migrated on other MEC platforms, assumed they expose the same standard APIs.

This approach aims to be more developer-oriented and provides a small set of APIs (suitable for some use cases), to hide the mobile network complexity. Technically, this kind of platform can be deployed as an independent VNF at the edge.

This approach could be useful in case the operator would like to promote a massive diffusion and development of edge applications, in a “public-cloud” approach. An extreme example of this kind of scenario could be to provide the Developer with the same platform of public cloud (with its own APIs and tools) extended in the edge. MEC Edge Computing scenario/technology is implemented in 5G EVE site in Greece but also planned in France.

Industry Specification Group for Multi-access Edge Computing (ETSI ISG MEC) is the home of technical standards for edge computing. The group has already published a set of specifications (Phase 1) focusing on management and orchestration (MANO) of MEC applications, application enablement API, service Application Programming Interfaces (APIs) and the User Equipment (UE) application API

While inside LTE networks the MEC has been seen as a component simply added on top of an already mature technology, 5G deployment and standardization process moving to Compute and Network Functions to the Edge has been considered fundamental in order to address use cases where low latency, high throughput or large bandwidth are important.

3GPP 5G system specifications define the enablers for edge computing, allowing an MEC system and a 5G system to collaboratively interact in traffic routing and policy control related operations [31].

The design approach adopted by 3GPP for 5G system allows the mapping of MEC onto Application Functions (AF) that can use the services and information offered by other 3GPP network functions based on the configured policies.

3GPP 5G system and MEC architecture are shown next (see Figure 20). The 5G architecture has been designed as an ecosystem of network functions where interworking elements using a Service-Based Architecture: the

network functions and the services they produce are registered in a Network Resource Function (NRF) and exposed externally using the Network Exposure Function (NEF). In the MEC architecture, the services produced by the MEC applications are registered in the service registry of the MEC platform [31].

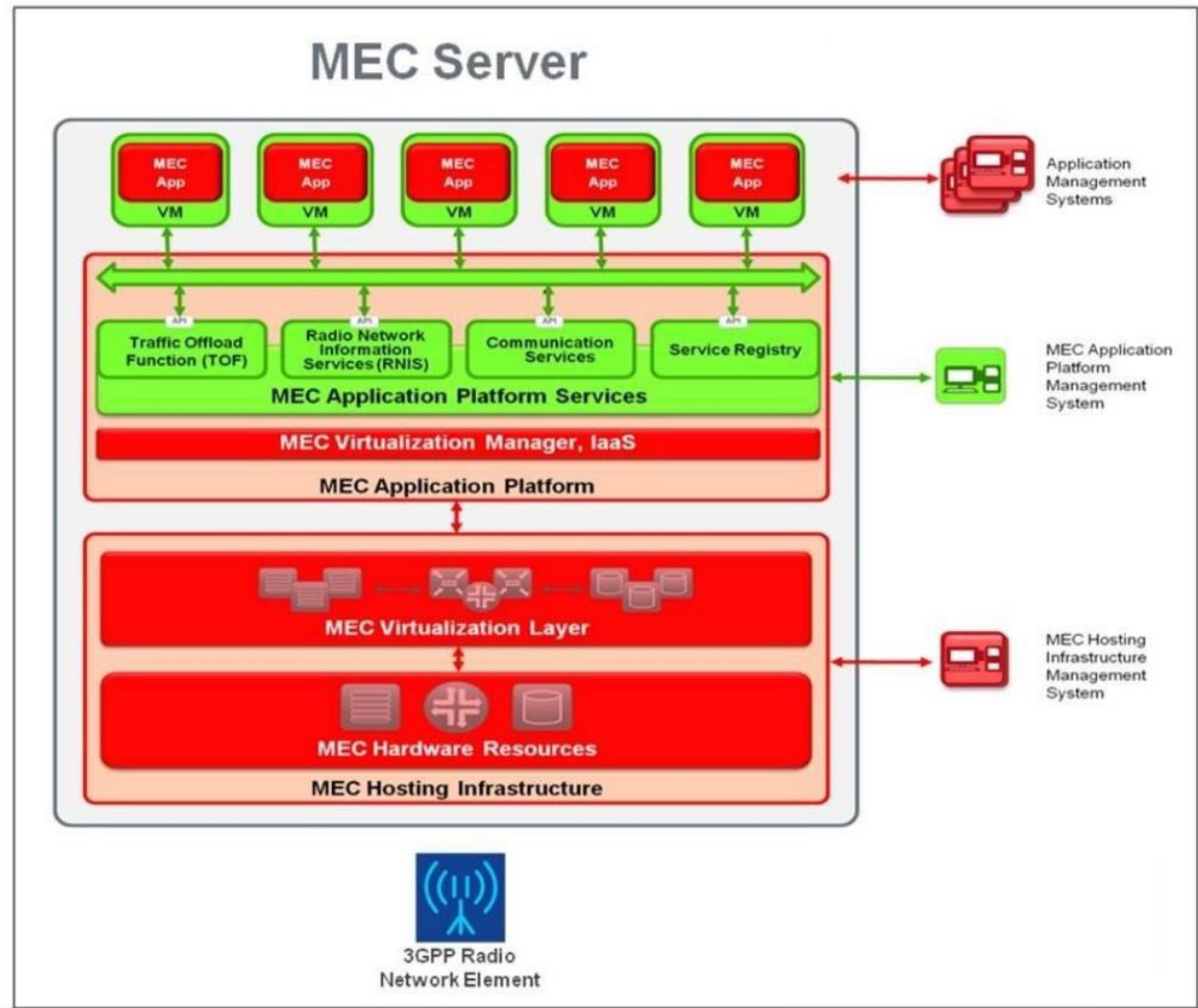

Figure 19: MEC architecture [30]

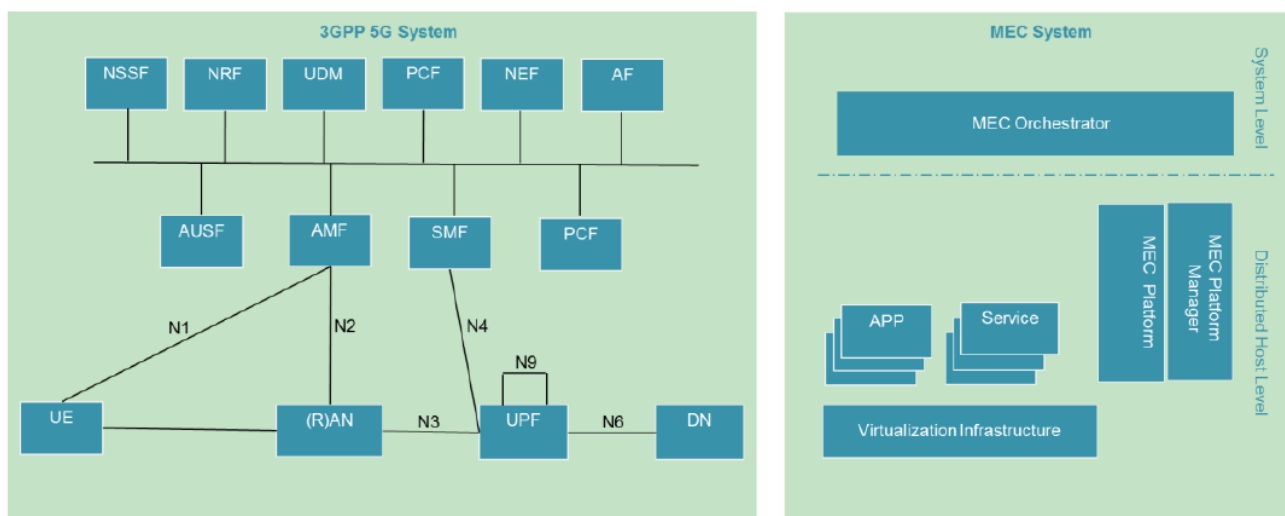

Figure 20: 5G Service Based Architecture (SBA) and MEC Architecture

In 5G EVE platform, Distributed Cloud solution for Edge Computing is available in Spain, Italy and Greece. MEC platform solution is also available in Spain 5G EVE facility.

3.2.3 NFV/SDN

Network Function Virtualization (NFV) and Software Defined Networks (SDN) are two pillars of 5G networks to target to meet the requirements of a highly mobile and fully connected society. Both technologies, SDN and NFV, address fundamental 5G demands concerned with high network flexibility as well as a service-driven approach. NFV was developed by service providers with a goal of accelerating an introduction of new services on the networks. Proprietary equipment applied in traditional networks by CSPs made impossible quick provisioning of new services. SDN has grown from an approach of programmable networks. In a programmable network, a behavior of network hardware and flow control is handled by software that operates independently from network hardware. A goal of these networks is to enable re-programming (using well-defined APIs) a network infrastructure instead of having to re-build it manually.

NFV is being standardized within the European Telecommunications Standards Institute (ETSI), while SDN's initial standardization efforts were undertaken in the Open Networking Forum (ONF). The Optical Internetworking Forum (OIF) standardizes also a form of SDN – Transport SDN. NFV and SDN are mutually beneficial but are not dependent on each other. Network Functions can be virtualized and deployed without an SDN being required and vice-versa. NFV benefits from SDN role in orchestration NFVI resources through features such as provisioning and configuration of network connectivity and bandwidth, automation of operations, security and policy control. SDN benefits from NFV-introduced concepts such as virtualized infrastructure managers and the orchestrator given that an SDN controller could run on a VM.

Software Defined Networks (SDN): Legacy IP networks are complex, difficult to manage and vertically integrated, for instance the control and data planes. The concept behind SDN is to break the vertical integration, by separating the network control logic from its underlying hardware, promoting (logical) centralization of network control, and introducing the ability to program the network by using well-defined interfaces (APIs).

In SDN context:

- **Data plane** (also called user plane, forwarding plane or U-plane): is a part of network that carries user's traffic; forwarding is based on rules as set by the control plane; other functionalities related to data plane are filtering, buffering, packet measurement etc. It is responsible for handling packets in the data path based on the instructions received from the control plane; actions of the forwarding plane include: forwarding, dropping, replicating and changing packets. The forwarding plane is usually the termination point for control plane services and applications.
- **Control plane** carries signaling traffic: refers to the logic of controlling and forwarding behavior; its main functionalities include tracking topology changes, installing forwarding rules, computing routes, service provisioning, etc.

SDN is an approach to decouple the control layer and the data/infrastructure layer of a network (i.e., switches, routers, etc.). In a conventional network, when a packet arrives at a switch, rules built into the switch's proprietary firmware tell the switch where (i.e., which port) to forward the packet. The switch sends every packet with the same destination address along the same path, even if the path is not globally optimal.

The goal of SDN is to allow the network to respond quickly to changing business demands. In a software-defined network, a network administrator can shape traffic from a logically centralized controller without having to touch individual network equipment. More precisely, SDN technology enables the administrator to change any network node's (e.g., router) rules when necessary, such as prioritizing and blocking specific types of packet flows in a very fine-granular level. All these can be just done by simply programming at the controller. Consequently, the network can be much more flexible, agile, and efficient by adopting SDN. Essentially, this allows the network to be much cheaper and less complex than ever before.

In 5G EVE project SDN-based network control is planned to enable dynamic programming of physical networks in transport as well as radio domains, based on one or more SDN controllers. For more details, refer to D3.1 [22]

SDN controllers will be used together with MANO layer at each site of the platform. Namely, each of the network facilities will provide a local orchestrator NFVO. Each of these orchestrators will have implemented internally SDN Controllers. There are two main MANO technologies in 5G EVE (ONAP and OSM), and Table 7 shows the SDN technology used for SDN controllers in each of them.

Table 7: Orchestrator's Technologies / SDN Technologies

Orchestrator’s technology	SDN technology
ONAP (Open Network Automation Platform)	- OpenDayLight SDN vanilla controller. - OpenDayLight based APIs.
OSM (Open Source MANO)	- OSM-RO (Resource Orchestrator) is in charge of providing SDN Controller functionalities. - It uses an internal library to manage the underlay connectivity via SDN which relies on OpenFlow pro-active rules to configure the connectivity in the switch; the current library includes plugins for FloodLight, ONOS and OpenDayLight.

Network Function Virtualization (NFV) aims at transforming a way in which networks will be designed and built by evolving standard IT virtualization technology allowing to consolidate many network equipment types onto industry-standard high-volume servers, switches and storage, which could be located in Data centers, Network Nodes, End-user premises...

It involves the implementation of network functions in software that can run on a range of industry-standard server hardware, and that can be moved to, or instantiated in, various locations in the network as required, without the need for installation of new equipment. Figure 21 presents a vision of Network Function Virtualization.

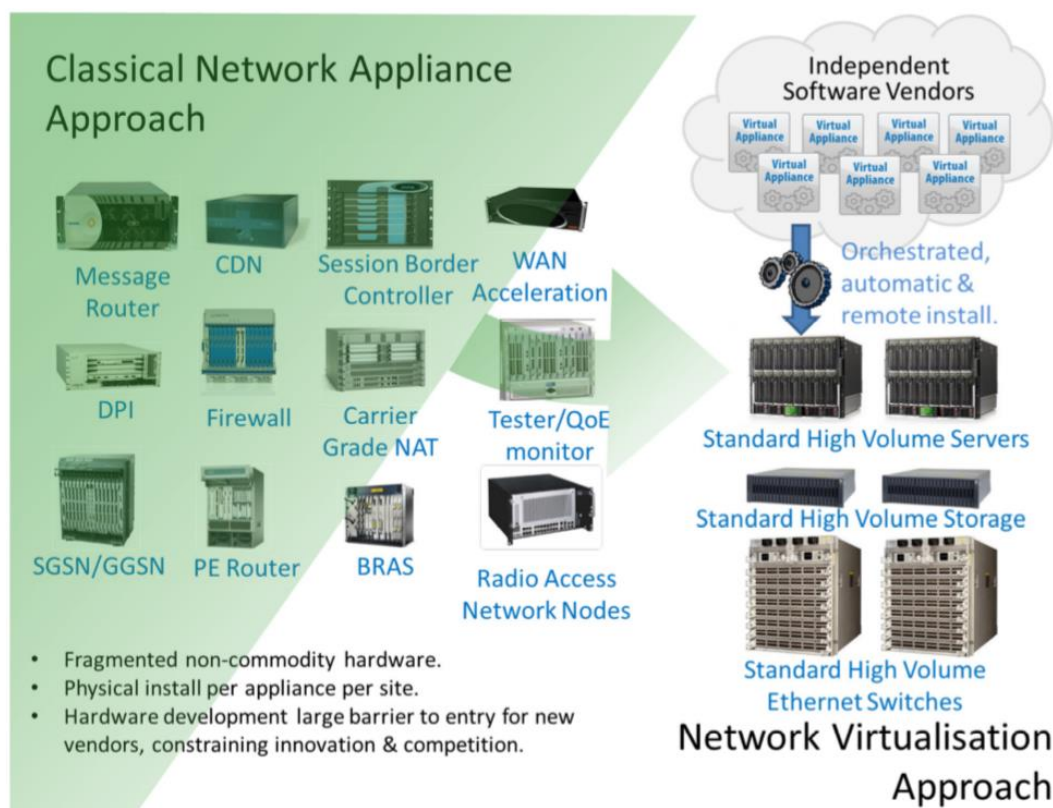

Figure 21: Vision for Network Functions Virtualization [32]

Future network services may be quite different than presently available network services. The new services will be comprised of a diverse set of non-virtualized and/or virtualized network functions, the latter supported by virtualized computing and network infrastructure, requiring interoperability among legacy and NFV-based network domains.

The overall service attributes, (in particular: reliability, availability, manageability, security, and performance) will depend on the individual (virtualized) network function attributes, as well as how these functions are connected.

Virtualization means that a network function and part of the infrastructure are implemented as a software component, and therefore, the NFV software architecture is an important aspect of the network architecture.

NFV introduces several differences in the way network service provisioning is realized in comparison to current practice. In summary, these differences can be described as:

- **Decoupling software from hardware:** As the network element is no longer a collection of integrated hardware and software entities, the evolution of both are independent of each other. This enables the software to progress separately from the hardware, and vice versa.
- **Flexible network function deployment:** The detachment of software from hardware helps reassign and share the infrastructure resources, thus together, hardware and software, can perform different functions at various times. Assuming that the pool of hardware or physical resources is already in place and installed at some NFVI-PoPs (Point of Presence), the actual network function software instantiation can become more automated. Such automation leverages the different cloud and network technologies currently available. Moreover, this helps network operators deploy new network services faster over the same physical platform.
- **Dynamic operation:** The decoupling of the functionality of the network function into instantiable software components provides greater flexibility to scale the actual VNF performance in a more dynamic way and with finer granularity, for instance, according to the actual traffic for which the network operator needs to provision capacity.

NFV Architectural Framework focuses on the aspects unique to virtualization. Three main working domains are identified in NFV reference architecture framework as depicted in Figure 22:

- VNF, as the software implementation of a network function which can run over the NFVI.
- NFV Infrastructure (NFVI), including the diversity of physical resources and how these can be virtualized. NFVI supports the execution of the VNFs.
- NFV Management and Orchestration (NFVO), which covers the orchestration and lifecycle management of physical and/or software resources that support the infrastructure virtualization, and the lifecycle management of VNFs. NFV Management and Orchestration focuses on all virtualization-specific management tasks necessary in the NFV Framework.

ETSI NFV architecture is a baseline for the implementation of infrastructures in 5G EVE. Different implementations of NFV Orchestrator and VNF Manager, based on ONAP and ETSI OSM are being considered in different 5G EVE sites, but also vendors proprietary solutions. Regarding virtualized infrastructure, in each facility, a few technologies are used to handle these components. The most common technologies used are OpenStack and Kubernetes, and the same as for NFVO and VNM, specific vendors' proprietary solutions as well. For further information on each site-specific implementation, refer to D2.1 [7] and D2.2 [8]

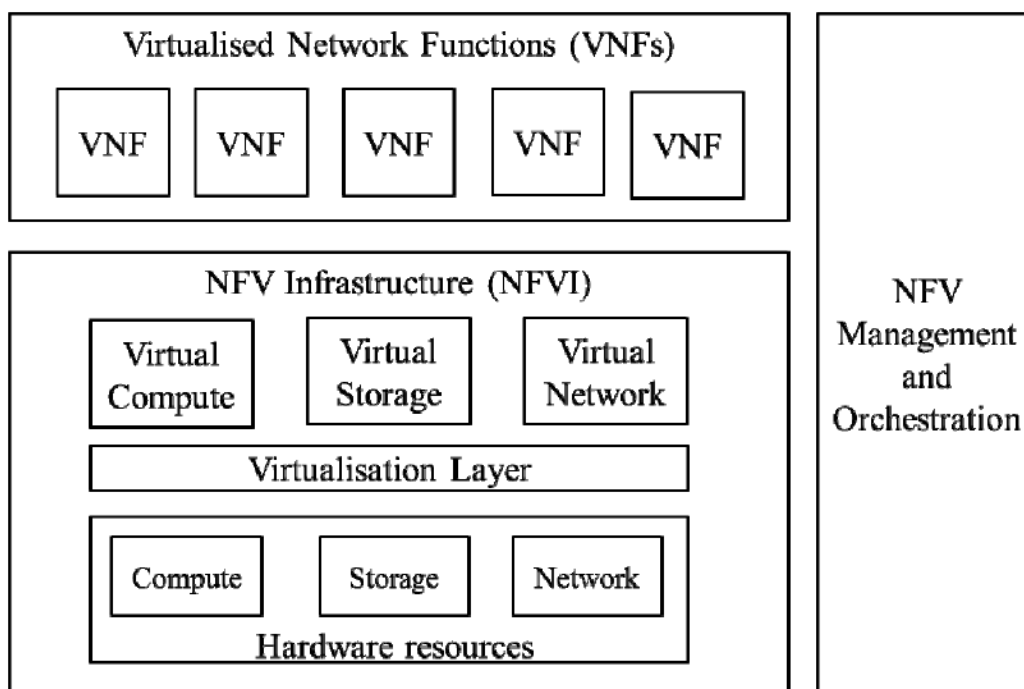

Figure 22: High level VNF Framework

3.2.4 5G NR

Within the scope of ITU recommendations for IMT-2020 systems, 3GPP provides complete system specifications for the 5G next-generation radio (5G NR) access. The submissions by the 3GPP made the 5G NR a candidate to the IMT-2020 fulfilling the considered requirements. After an initial release in late 2017 and a next completion in 2018, a 5G radio specification has been delivered in 3GPP Release 15 (also called Phase 1), as shown in Figure 23.

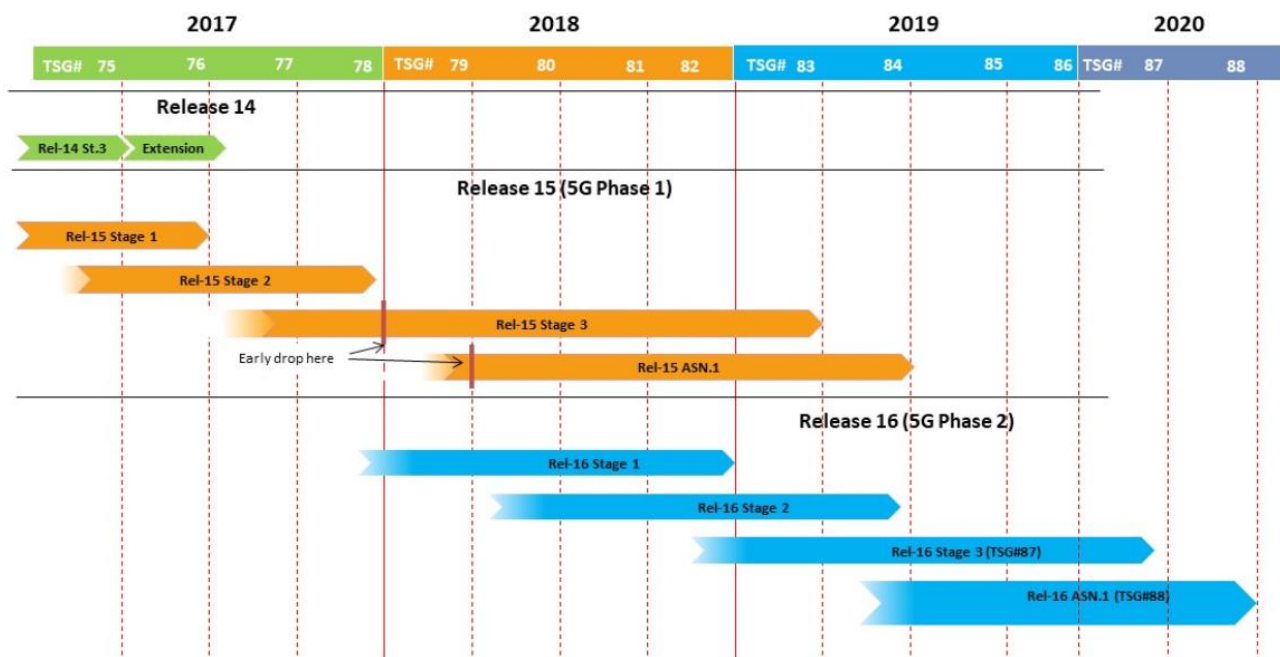

Figure 23: 3GPP Release Freeze and End dates [33]

While initial specifications enabled non-standalone 5G radio systems integrated into previous-generation LTE networks, the scope of Release 15 expands to cover ‘standalone’ 5G, with a new radio system (NR) complemented by a next-generation core network. It also embraces enhancements to LTE and, implicitly, the Evolved Packet Core (EPC). This crucial way-point enables vendors to progress rapidly with chip design and initial network implementation.

One of the 5G's main characteristics is the introduction of a new radio interface, the New Radio (NR), which offers the flexibility and capabilities needed to support these very different types of services.

Two deployment options are defined for 5G:

- Non-Stand Alone (NSA) architecture, where the 5G New Radio (NR) interface is used in conjunction with the existing LTE and EPC infrastructure Core Network (respectively 4G Radio and 4G Core), thus making the NR technology available without network replacement. The NSA is also known as "E-UTRA-NR Dual Connectivity (EN-DC)" or "Architecture Option 3".
- Stand-Alone (SA) architecture, where the NR is connected to the new 5G CN also specified in 3GPP Rel-15.

The 5G NSA architecture is illustrated in Figure 24:

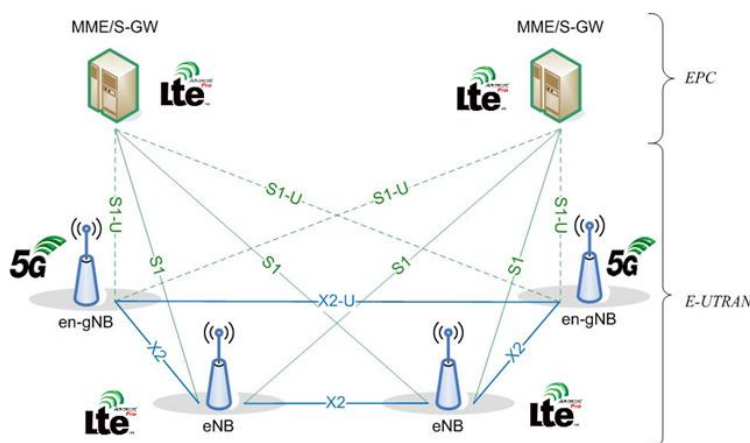

Figure 24: 5G NSA Architecture

The 5G NSA architecture can be seen as a temporary step towards "full 5G" deployment, where the 5G Access Network is connected to the 4G Core Network. In the NSA architecture, the (5G) NR base station (logical node "en-gNB") connects to the (4G) LTE base station (logical node "eNB") via the X2 interface. The X2 interface was introduced prior to Release 15 to connect two eNBs. 5G NSA offers dual connectivity, via both the 4G AN (E-UTRA) and the 5G AN (NR). It is thus also called "EN-DC", for "E-UTRAN and NR Dual Connectivity". In EN-DC, the 4G's eNB is the Master Node (MN) while the 5G's en-gNB is the Secondary Node (SN).

The SA architecture is illustrated in Figure 25:

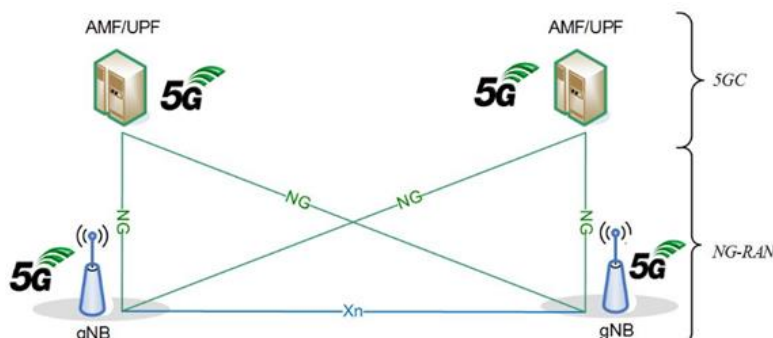

Figure 25: 5G SA Architecture

The NR base station (logical node "gNB") connects with each other via the Xn interface, and the Access Network (called the "NG-RAN for SA architecture") connects to the 5GC network using the NG interface. The continuation of this chapter refers to the SA architecture as final architecture of the 5G deployment. The overall architecture for the Access Network [34] is shown in Figure 26.

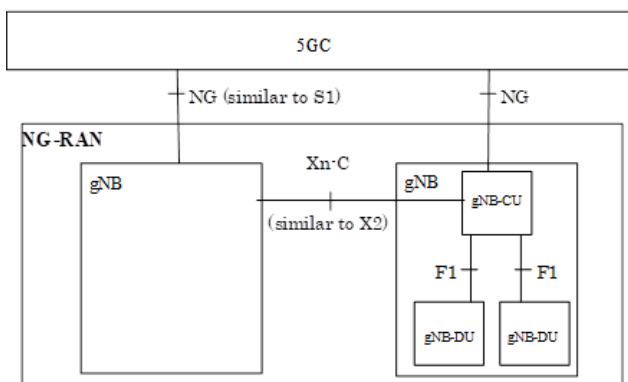

Figure 26: Overall NR architecture

The NG-RAN consists of a set of gNBs connected to the 5GC (5G Core) through the NG interface, based on (and very similar to) the LTE's S1 interface. The gNB (5G Node B) can be connected to another gNB through the Xn interface, based on (and very similar to) the LTE's X2 interface. The gNB may be further split into a gNB-Central Unit (gNB-CU) and one or more gNB-Distributed Unit(s) (gNB-DU), linked by the F1 interface. One gNB-DU is connected to only one gNB-CU.

It is also worth to mention that Rel-16 NR specifications expected to be released early 2020, will contain a wide range of new features (see Figure 27) that will help to further improve 5G performance and address new use cases.

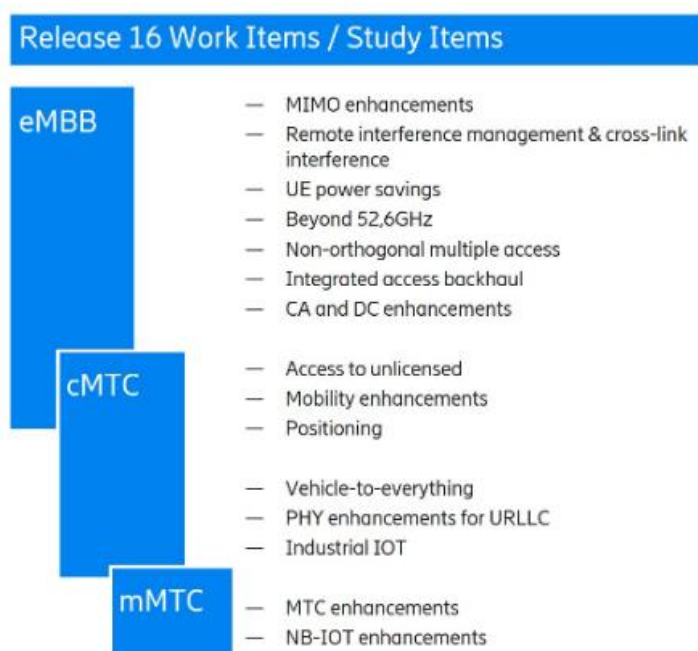

Figure 27: Rel-16 NR Work Items [35]

5G NR Features

- New Bands and increased bandwidths:** NR can be deployed in a very range of bands both in existing IMT delivered intervals and in future bands. The differences between bands are very pronounced for NR due to the very wide range of frequency bands.

Frequency bands within the scope of the present Release 15 work in 3GPP are divided into two frequency ranges¹⁶:

- Frequency range 1 (FR1) includes all existing and new bands below 6 GHz.
- Frequency range 2 (FR2) includes new bands in the range 24.25-52.6 GHz.

Note: Refer to 3GPP TS 38.101-1 [36] and 3GPP TS 38.101-2 [37] for further information on 5G NR radio transmission and reception bands

- **Massive MIMO & beamforming:** Multiple-input and multiple-output (MIMO) is a key technology to improve throughput. It uses multiple antenna arrays both on the transmitter and on the receiver sides, as to enable multi-layer data transmission.

NR supports multi-layer data transmission for a single UE (single-user MIMO) with a maximum of eight transmission layers for DL and four ones for UL. NR supports also multi-layer data transmission with multiple UEs on different layers (multi-user MIMO) with a maximum of twelve transmission layers for DL and UL transmission.

Since NR supports multi-beam operation where every signal/channel is transmitted on a directional beam, beamforming is an important technique for achieving higher throughput and coverage especially, in high-frequency range.

- **Multi-Services transmission:** A very wide range of deployment scenarios has been considered for 5G; from large cells with sub 1 GHz carrier frequency up to mm-wave deployments with a large spectrum allocation.

A flexible OFDM numerology (μ) with subcarrier spacings ranging from 15 kHz (used in LTE) up to 240 kHz has been considered in 3GPP TS 38.211 [38]. Different numerologies can be used simultaneously in a cell. Compared to LTE, higher carrier spacing allows achieve lower latency in the air interface.

- **Native end-to-end support to Network slicing:** 5G and in particular NR have to support and facilitate Network Slicing serving simultaneously very different business or customer needs from a single service-based architecture.

On the same physical core and radio networks, different slices can run as, for example, one supporting mobile broadband application in full mobility, as provided by the legacy LTE system, and another slice delivering as an example, non-mobile, latency-critical industry-automation application.

Despite such slices are running on the same physical network from the end-user point of view they appear as independent networks and each of them may provide different network capabilities.

The characteristics of each slice are defined in terms of QoS, bit rate, latency, etc. For a given slice, these characteristics are either predefined in the 3GPP Standard or are operator-defined.

There are three types of predefined slices: type 1 - is dedicated to the support of eMBB, type 2 - is for URLLC and type 3 - is for MIIoT support. These predefinitions allow inter-PLMN operation with reduced coordination effort between operators. As for the operator-defined slices, they enable more differentiation among Network Slices. A dedicated Network Function in 5G Core Network is introduced for handling slices: the "Network Slice Selection Function" (NSSF), which enables the selection of the appropriate slice(s). The UEs may use multiple Network Slices simultaneously.

¹⁶ Note: Refer to 3GPP TS 38.101-1 [36][32] and 3GPP TS 38.101-2 [37][33] for further information on 5G NR radio transmission and reception bands

4 5G EVE Platform – Anatomy

The services offered by the 5G EVE platform so support the experiment flow described in section 2 leverage on the 5G EVE platform architecture described in this section. 5G EVE facility is composed of the following sites: Spanish, Greek, Italian and French sites. The 5G EVE Platform functional architecture is shown in Figure 28.

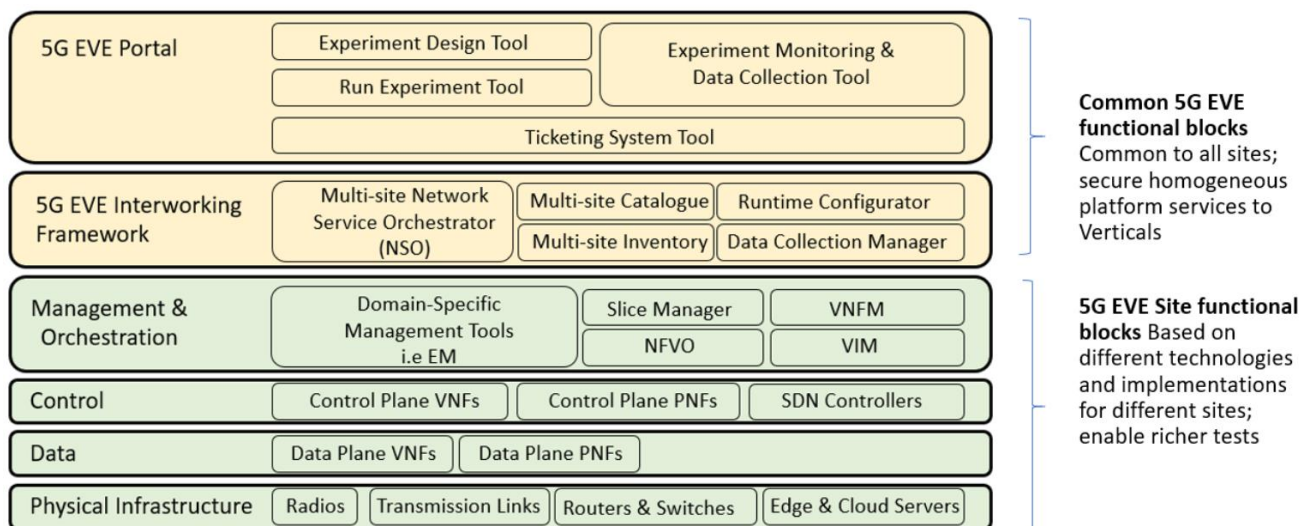

Figure 28: 5G EVE functional architecture

As it can be observed, the functional layers can be grouped in two main blocks:

- 5G EVE common blocks (common and shared by all sites): Service Layer including I/W Framework and 5G EVE portal, which include functionalities common and shared by all sites.

5G EVE site-specific blocks (where technologies implemented can be different on each site): [physical infrastructure layer, network layer (data layer & control layer) and M&O layer]. It is important to note that technology/HW/SW components described in this section that belong to layers in 5G EVE site-specific functional blocks are available in at least one site of 5G EVE E2E facility, but not necessarily in all sites. Information on what technology/HW/SW component is available on each site is included in D2.1 [7], whereas information of planning dates for the deployment of them on each individual site is covered in D2.2 [8] “Common” functional block comprises innovative 5G EVE Platform functions such that:

- Facilitate *Experimenter* interaction with the platform using a single point of Access.
- Support manages and orchestrates Network Functions from different sites to provide end-to-end Service requested by *Vertical*.

“Site-specific” functional blocks allow that:

- Sites may implement different technologies for the same functional block.
- Sites implementation planning may be handled independently on each site.

Since Site-Specific functional blocks can use different technologies in different sites, not all sites could initially be suitable for all use cases/experiments. An example is, for instance, one site which supports mMTC devices of type CAT-M, when another only supports NB-IoT devices. This type of information will be available for *Vertical* and *Experimenter* and is a key input during Test Design and Preparation phases.

The availability of technologies available in each site, and so, its capabilities, should be considered during Experiment design phase. Note that two sites could fulfill the performance requirements of a particular use case, but it should be noted during the experiment design phase that this could have an impact in the expected

performance of a particular KPI, i. e., 5G NR and LTE aggregated bandwidth impacting throughput and capacity, Edge Computing / MEC availability impacting E2E latency, etc.

5G EVE platform architecture blocks can be mapped to architecture described in 5G Overall architecture Framework in 5GPPP for 5G User Equipment (UE) networks [39], as shown in Figure 29:

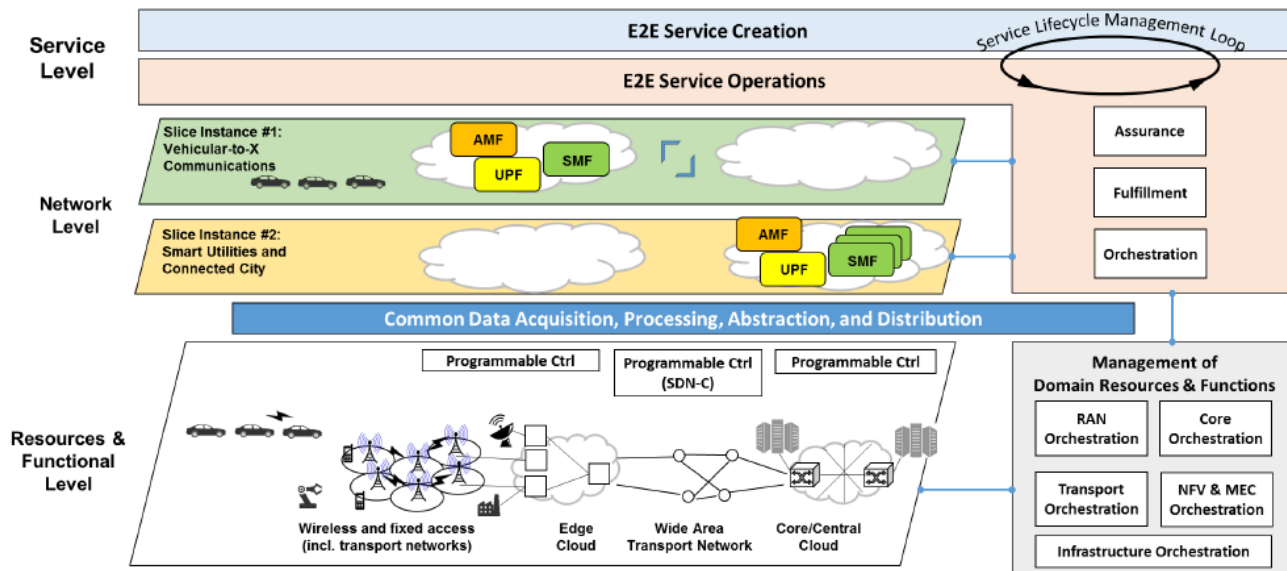

Figure 29: 5G PPP - 5G Overall architecture Framework

“E2E Service Creation and E2E Service Operations” boxes will be represented in 5G EVE platform by 5G EVE common blocks whereas “Management of Domain Resources & Functions” box would be represented in 5G EVE platform by 5G EVE site-specific blocks.

4.1 Physical infrastructure layer functions

Physical Infrastructure layer offers resources (network, compute, storage) to network services to allow providing the E2E communication service. Radios provide air interface resources controlled by (Radio) Access Network ((R)AN), whereas front-haul and back-haul network both provide transport network resources in the non-air interface. All of them could be provisioned and controlled using SDN controllers or other specific functions from the control layer. Edge & Network clouds provide computing and storage resources for service applications or Network Functions, covering from Radio Access Network (RAN) and Core Network (CN) functions to *Vertical* VNFs.

Each of the four sites (Spanish, Greek, Italian and French) are connected via a VPN from the centralized input entrance and connected to the common 5G EVE portal with the other European sites.

With regards to the air interface radio resources, different bands and bandwidths will be available in 5G EVE platform. Currently, LTE is available in different bands with different propagation characteristics. Lower bands have better penetration / lower attenuation and they are the most indicated for running IoT experiments. On the other hand, higher frequency bands normally have higher bandwidths available and are the ones used to reach higher throughputs.

Long Term Evolution (LTE) bands available in 5G EVE are B7, B14, B20, B28, B38, and B42. For 5G NR, NR on 3.7 GHz (n78) and NR on 26 GHz (n258).

For 5G NR, NR on 3.7 GHz (n78) is primarily expected to be used in 5G EVE since it is already available in some countries, it is the primary band suitable for the introduction of 5G-based services and it will bring the necessary capacity for new 5G services in urban areas.

For the initial EU 5G deployments, the existing mobile spectrum will be made available at 700 MHz to provide nation-wide and indoor 5G coverage. This will enable 5G coverage to all areas, ensuring that everyone benefits from 5G. This is subjected to official frequency auctions in each European country. For instance, in Spain, frequencies for 5G NR usage in 700 MHz band are planned to be auctioned in 2020.

In parallel, additional spectrum must be identified, so new bands are studied between 24.25 GHz and 86 GHz for identification by the next World Radiocommunication Conference (WRC-19) under Agenda Item 1.13. NR on 26 GHz (n258) is expected to be used in 5G EVE with high bandwidth that will bring ultra-high capacity for innovative new services, enabling new business models and sectors of the economy to benefit from 5G [40].

A simplified end-to-end network architecture including the connected device, RAN, and Core network is illustrated in Figure 30. Note that the Core network can be physically deployed on the same site as the RAN, but it can also be relocated into another site while respecting connectivity and delay constraints (see section 0 “Multi-site Multi-domain slicing and orchestration” for more details of the availability of using network functions from different sites). The devices could be commercial smartphones or any other connected device.

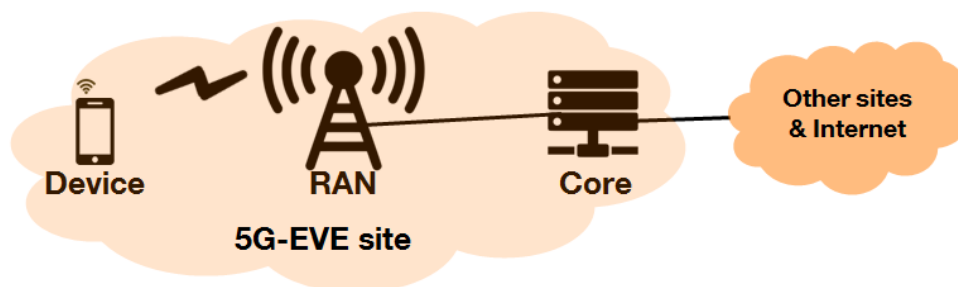

Figure 30: End-to-end network architecture (simplified view)

In 5G EVE sites, RAN infrastructure is composed of a set of reusable open-source or proprietary software components as well as hardware equipment. The software components include for example VNFs based on Docker containers or Virtual Machines, elementary or composite RAN software functions running as micro-services, pre-commercial RAN components from vendors like Airscale radio network controller, etc.

Hardware equipment includes software-defined radio peripherals, such as USRP cards, antennas, commercial smartphones, high-performance servers, or even radio commercial equipment like Ericsson radio Air 6488. The available software modules e.g., open-source RAN code from Open Air Interface (OAI) Alliance deployed and running on convenient hardware resources, provide a standard-compliant implementation of 3GPP 4G and 5G RAN functionalities.

Next, we provide a non-exhaustive list of different radio access technologies available at 5G EVE sites, as well as software and hardware components:

- Radio access technologies:
 - 4G network with the possibility to choose the adequate transmission frequency and operating bandwidth according to use-case requirements and site constraints e.g., LTE Bands 40/38/7, Time Division Duplex (TDD) or Frequency Division Duplex (FDD).
 - 5G NR network with the convenient transmission frequency and bandwidth. Compared to 4G, larger bands are available along with Multiple-input Multiple-output (MIMO) transmissions that allow to significantly increase RAN throughput, especially for eMBB use-cases. Higher carrier spacing configuration will also reduce transmission delays and will support URLLC use-cases requirements.
- Software components:
 - 3GPP-compliant open-source software-based eNodeB and 4G UE.
 - OAI 5G NR gNodeB code which is currently under development and test by Eureka.
 - Monolithic eNodeB/gNodeB VNFs available in Docker containers or Virtual Machine images.
 - Disaggregated RAN functions to be orchestrated and running as micro-services.
 - Other RAN-related software components such as RAN monitoring dashboard and slicing management application.

- Hardware components:
 - Commercial smartphones.
 - Software radio peripherals and antennas.
 - High performance servers.
 - High-speed switches.
 - Power amplifiers, duplexers, and transmission (TX)/reception (RX) radio switches.
 - Indoor and outdoor eNodeBs or pre-commercial gNodeBs.

It is worth to note that the RAN infrastructure includes an OAI-based flexible architecture that aims at providing a 4G/5G service delivery platform to *Vertical* players. Accordingly, OAI provides a software-defined implementation of RAN functionalities enabling the configuration of various radio parameters on-demand.

Moreover, from a *Vertical* perspective, the RAN architecture shall offer the possibility to configure the radio resources in an abstracted way. To this end, the RAN infrastructure includes an SDN-based RAN controller, i.e., FlexRAN, that enables the monitoring and configuration of the radio resources in an abstracted manner.

Specifically, by using such an SDN-based architecture, the control plane of the MAC layer can be separated by the data plane and executed as a northbound application in a centralized SDN Controller (control layer). This opens the road for a more flexible resource scheduling approach, facilitating the implementation of novel policies for adapting the RAN to the services requested by the Verticals.

For instance, the *Vertical* player can interact with the RAN via a set of northbound APIs (NBI) requiring a specific amount of radio resources for performing his services. An example of the logical architecture for the SDN-based RAN approach is depicted in Figure 31. The RAN is configured in a transparent manner, based on the vertical’s needs.

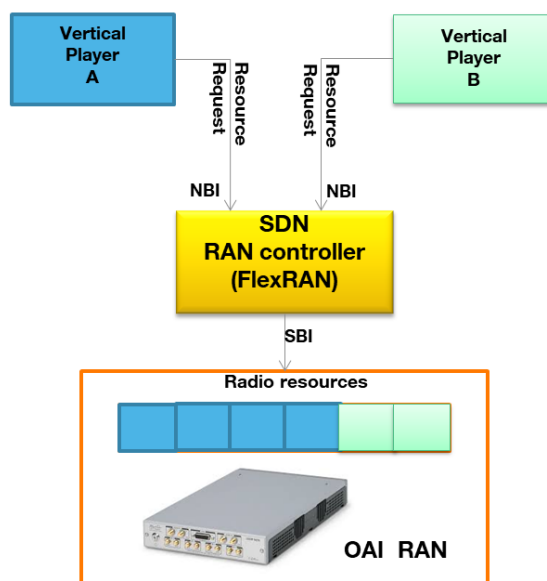

Figure 31: SDN-based RAN Approach

Core Network Functions will be implemented as proprietary or open-source VNFs (5G vEPC and 5GC) in different types of servers, depending on the site. For instance, 5G Evolved Packet Core (EPC) HW in Greece uses either HDS 8000 CRU or Dell 630 as HW whereas in France, 5G EPC NFs are virtualized in AirFrame servers.

Distributed cloud architecture is also used in 5G EVE sites to provide Edge Computing/MEC capabilities. This allows allocating some computing resources at the edge of the network that runs a set of virtual entities implementing operators’ Network Functions (usually the functions related to the virtual EPC User Plane (UP)) and local applications from the operator itself or from the Verticals.

4.2 Network Layer

5G network's main driver is to efficiently meet all range of mobile service requirements. With software-defined networking (SDN) and Network Functions Virtualization (NFV) supporting the underlying physical infrastructure, 5G is migrating the access, transport, and core networks parts toward cloud infrastructure. Cloud adoption allows better support for diversified 5G services, and enables the key technologies of E2E network slicing, on-demand deployment of service anchors, and component-based network functions. Cloud-RAN architecture for example, embeds mobile sites and mobile cloud engines and coordinates multiple services, operating on different standards. Multi-connectivity is introduced to allow on-demand network deployment for RAN non-real time resources. Networks implement policy control using dynamic policy, user and network data stored in the unified database on the core network side.

Network plane functions support the execution of E2E communication services. Service traffic makes usage of user plane (UP) Network Functions along different network segments (radio, core network, and service cloud) to transfer data end to end. On the other hand, Control plane (CP) Network Functions are used to control the execution of E2E communication services.

The 5G System architecture shall support service-based interactions between control plane CP and UP network functions guided by a set of predefined principles [41], including:

- Separate the UP functions from the CP functions, allowing independent scalability, evolution and flexible deployments: centralized location or distributed (remote) location.
- Modularize the function design, to enable flexible and efficient network slicing.
- Define procedures (i.e. the set of interactions between Network Functions) as services so that their re-use is possible.
- Enable each Network Function (NF) to interact with other NF directly if required.
- Minimize dependencies between the Access Network (AN) and the Core Network (CN).
- Support a unified authentication framework.
- Support "stateless" NFs, where the "compute" resource is decoupled from the "storage" resource.
- Support capability exposure.
- Support concurrent access to local and centralized services. To support low latency services and access to local data networks, UP functions can be deployed close to the Access Network.
- Support roaming with both Home routed traffic as well as Local breakout traffic in the visited PLMN.
- Involve different administrative domains and thus will be built on network slicing based on a per-service basis, therefore building an E2E slice structure.

Network slice capabilities provide guarantees for: (i) isolation in each plane (Data plane, Control plane, Management plane) by having enablers for safe, secure and efficient multi-tenancy in slices; (ii) the end-to-end QoS of a service within a slice by monitoring the status and behavior of NS. It allows a slicing hierarchy and provides capabilities to trade between flexibility and efficiency and assures an automatic selection of network resources and functions.

In the 5G system (see Figure 32), the Network Slice (through which the network service is provided to end-user) includes RAN and CN network functions including the user plane function (UPF), control plane function (SMF) and other network functions normally shared by different slices (AMF, PCF).

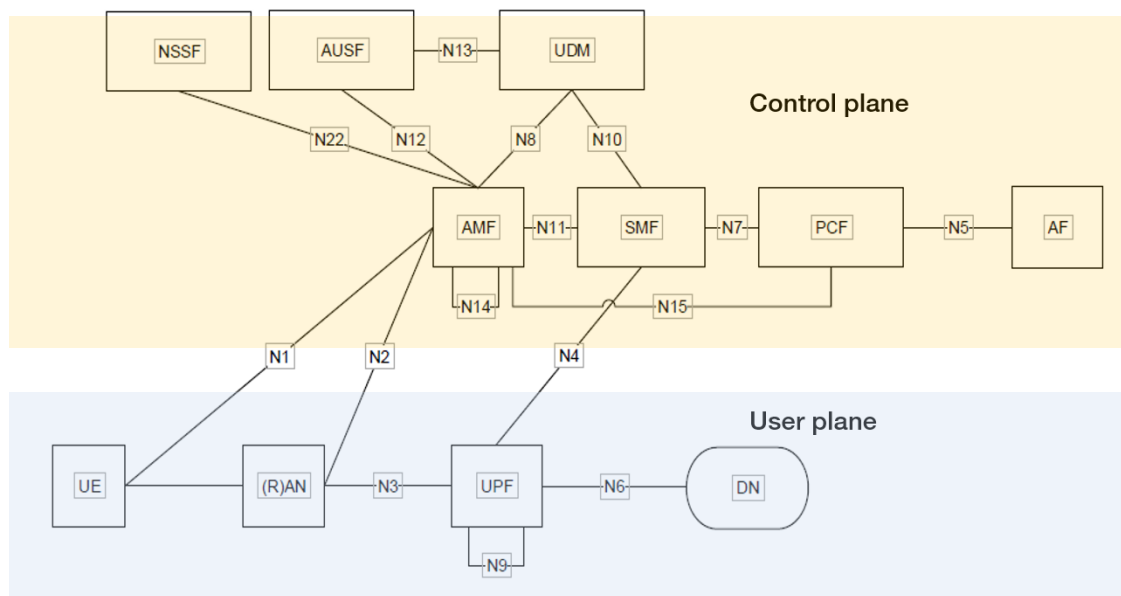

Figure 32: 5G System Architecture [42]

Component-based control planes and programmable user planes allow for network function orchestration to ensure that networks can select corresponding control-plane or user-plane functions according to different service requirements.

The 5G System architecture provides support for data connectivity and service deployment capabilities to access and use Network Function Virtualization and Software Defined Networking techniques, facilitating interactions between Control Plane (CP) Network Functions. To allow independent scalability, evolution and flexible deployments in centralized or distributed configuration a separation between the user plane (UP) functions from the control plane (CP) functions should be provided. Control Plane separation from the User Plane layer is referring to dissociation of control plane functions (in charge with the user connection management, QoS policies definition, user authentication) from the user plane functions (which deal with data traffic forwarding) to enable user plane functions to scale independently, allowing operators for a more flexible deployment and dimensioning of the network. If data traffic increases, more data plane nodes can be added without affecting the control plane functions. The abovementioned segregation allows user plane programmability to configure more than one data plane node to be selected and treated for a particular role (a data plane gateway, router or switch) as forwarding, encapsulation, traffic steering, to fulfill requirements according to the indications received by the control plane elements. Different data plane solutions can coexist in the same user plane and to be dynamically selected according to the needs of the specific traffic.

Communication services make use of user plane network functions along different network segments (radio, CN and service cloud) to transfer user data. Simultaneous UE user plane services can be obtained via multiple, separate Network Slices providing UE with data services from different Data Networks as shown in Figure 33.

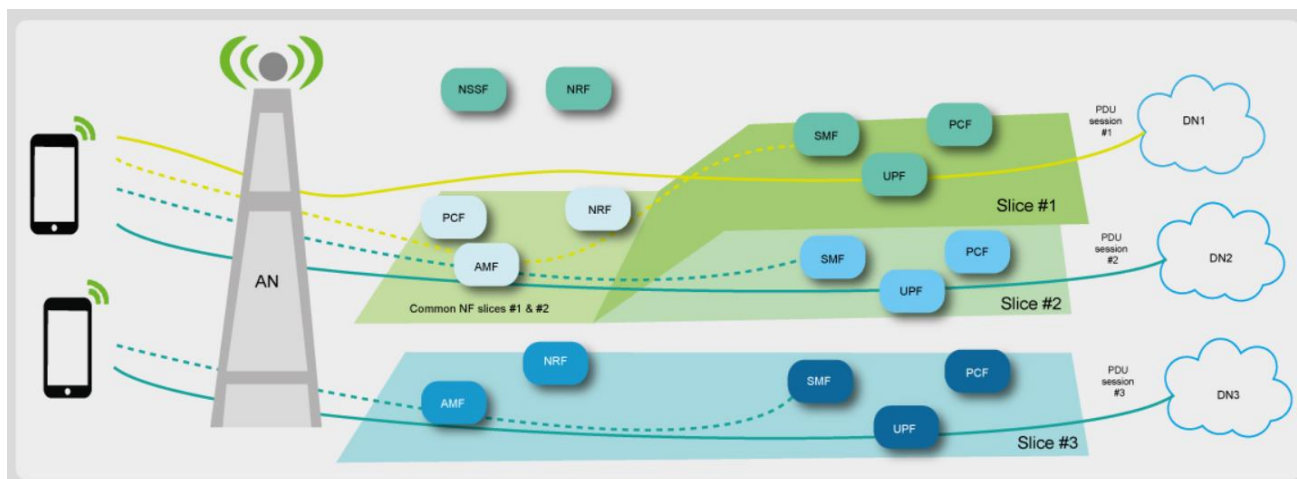

Figure 33: 3GPP deployments using network slicing [43]

5G EVE project has 4 site facilities, each one with specific functionalities deployed based on vertical use cases demonstration requirements. Following, an overview of the Data and Control layer network functions used in 5G EVE platform is included.

4.2.1 RAN

The RAN base is constituted of two parts: a hardware (HW) and a software (SW) base. The HW comprises the baseband node and radio unit(s). The software includes the components needed to operate the 3GPP wireless system including LTE (up to 3GPP Rel-14 [44]) and 5G (3GPP Rel-15 [4] and upwards).

For traditional RAN, components RU (radio unit) and BBU (baseband unit) are hardware, connected through Common Public Radio Interface (CPRI) or Evolved Common Public Radio Interface (eCPRI). In this case Fronthaul increases due to massive MIMO and the L1 from Baseband Unit (BBU) function is loaded. The connection between 4G-BBU and 5G-BBU is made via X2 interface. For virtualized RAN, the baseband function is divided into two units: Distributed Unit (DU) and Centralized Unit (CU). The DU processes L1, Medium Access Control (MAC) and Radio Link Control (RLC) layers, the CU is in charge with Radio Resource Control (RRC), Packet Data Convergence Protocol (PDCP), S1/X2.

These protocols are grouped into three Open System Interconnection (OSI) layers: L1 equivalent with Physical Layer (PHY), L2 containing MAC, RLC and PDCP; and L3 which is based on RRC. From user-plane point of view, and compared to 4G architecture, a new protocol is added in the 5G system on top of PDCP layer, called Service Data Adaptation Protocol (SDAP). The RLC and MAC layers are similar for both planes, user and control, as shown in Figure 34.

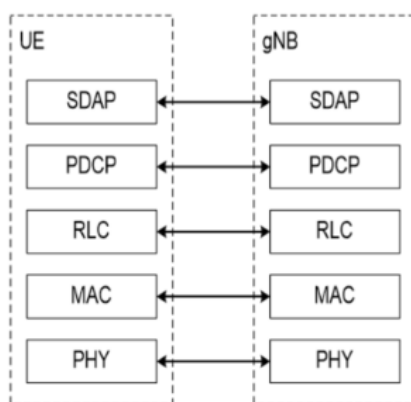

Figure 34: User plane protocol stack

The SDAP layer implements mapping from 5G Quality of Service (QoS) flows to data radio bearers (DRB) in the air interface between UE and gNB. One or more QoS flows may be established in a PDU session (between UE and CN). Each QoS flow has its own QoS attribute set (5QI set it by SMF function from 5GC) and is uniquely identified by the QoS Flow Identifier (QFI). For each UE, 5GC establishes one or more PDU sessions. For each UE, one or more DRBs can be established in one PDU session (see Figure 35).

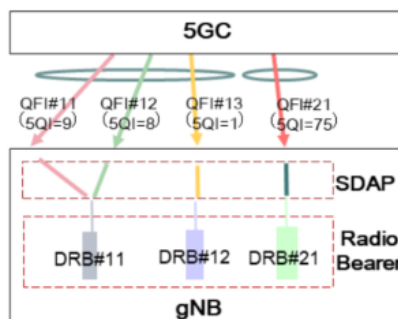

Figure 35: Mapping of QoS flows on DRBs

The PDCP layer on the NR network inherits the functions on LTE network (transmission of data on the control and user planes; encryption, decryption, and integrity protection; discarding due to duplication; Robust Header Compression (ROHC) – for user plane) and integrates other functions, like routing and replication (in Dual Connectivity scenario) and reordering.

5G NR will be tightly integrated with legacy 4G, e.g. seamless mobility between 4G and 5G, Dual Connection between 5G and 4G radios. First, 5G deployments will be based on 3GPP Rel15 specifications, where several architecture options are defined, using LTE and/or NR on the radio side, using EPC and/or a New Generation Core Network on the CN side or 5GC.

In the first phase, three options of an NSA (Non StandAlone) NR architecture will be implemented in 5G EVE platform, with EPC for the core side. One of them, named Option 3x (see Figure 36), is an option in which the UE is connected with EPC via eNB for the control plane, and through both RAN nodes, eNB and NR, for the user data plane. LTE manages the 5G traffic in the mobility scenario. The user Data Radio Bearer is set up either as Split bearer, i.e. using both LTE and NR radio resource or as LTE-only bearer (using only LTE radio resources). The reason to support both DRB bearers is to grant to legacy UE to be connected to 4G network and 5G UE that are out of NR coverage to benefit from the service access.

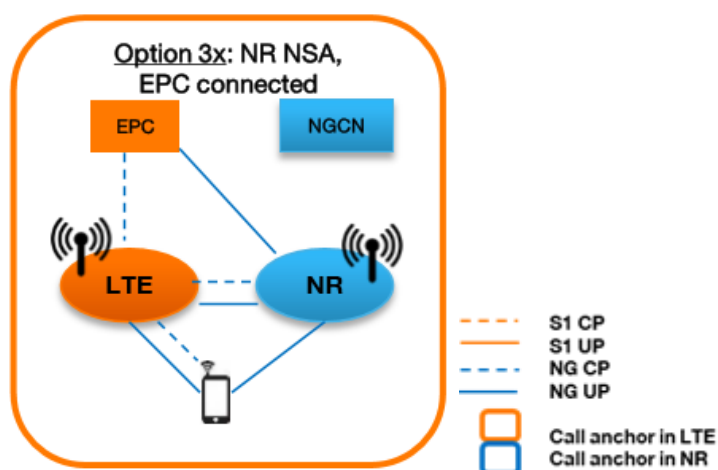

Figure 36: Option 3x - 5G NSA

Another NSA architecture option which will also be implemented in one of the 5G EVE testbeds is Option 3a, depicted in Figure 37. The UE is connected with EPC on the control plane via LTE, the UE is connected with EPC on the user plane via both RAN nodes, LTE and NR respectively. A temporary bearer is established between EPC and UE via LTE eNB.

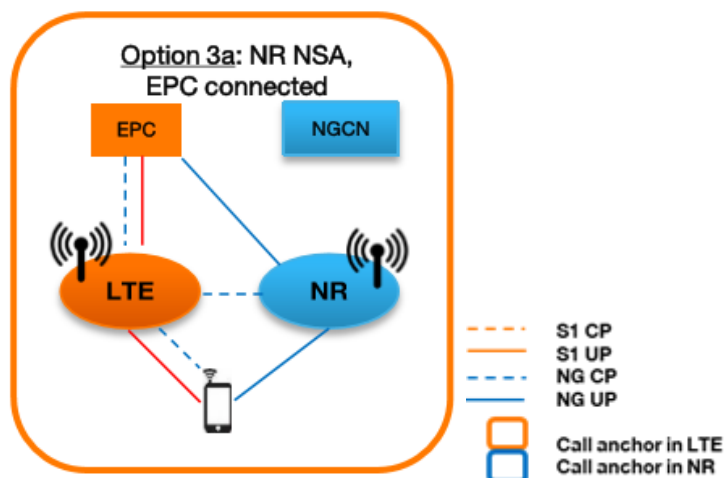

Figure 37: Option 3a - 5G NSA

The third option implemented is Option 3 (see Figure 38), where the UE is connected to RAN NBs (LTE and NR) for the user plane, and with LTE for the control plane. In this case, only LTE is connected to the EPC, on the control and user plane. The whole traffic is managed by the LTE, the EPC has no view of the 5G NR

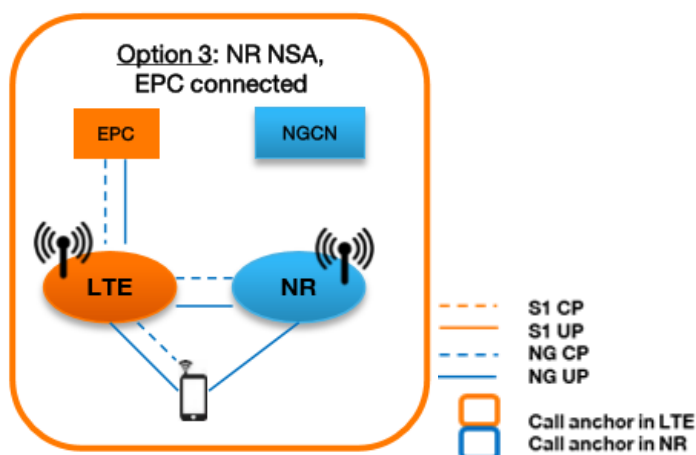

Figure 38: Option 3 - 5G NSA

In the second phase, 5G EVE sites will evolve to support 5G SA architecture. 5G SA Option 5, presented in Figure 39 uses 5GC and LTE ng-eNB access. Then, LTE is connected on the control and user plane to the 5GC.

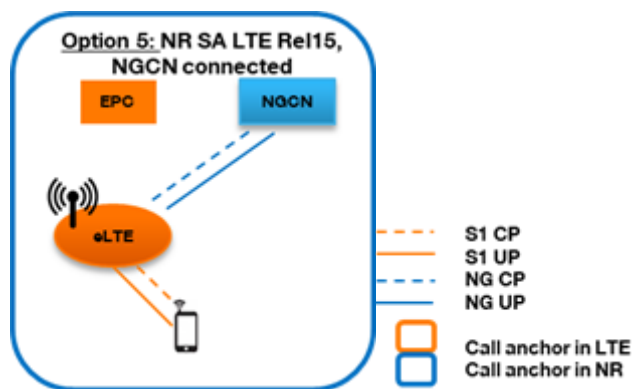

Figure 39: Option 5 - 5G SA

Finally, 5G SA Option 2 (Figure 40) is using the 5GC, capable for eMBB, mMTC and URLCC. A Standalone NR is connected to 5GC and the gNB is connected on both control and user plane to the 5GC.

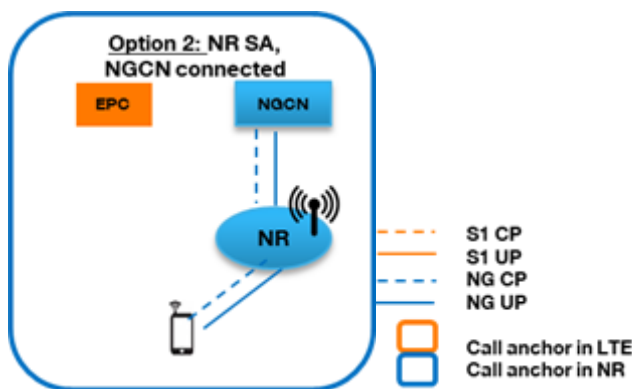

Figure 40: Option 2 - 5G SA

Different solutions/technologies are used in different 5G EVE sites implementing 5G RAN NFs. Nokia Proprietary Solutions are used in France and Ericsson Proprietary Solutions in Spain, Italy and Greece. In addition, there are plans to integrate Nokia Proprietary Solutions in Spain and OpenAirInterface (OAI) in France.

4.2.2 Core

5G EVE platform will have CN legacy (4G EPC and 5G EPC) and new 5G Core Network included in the 5G system (5G CN), necessary for all services required by vertical use cases. For cost-effective reasons and due to low number of subscribers on testbed a virtualized solution will be used. Each function is deployed like a Virtual Network Function (VNF). More than that, a further evolution of the VNF single server deployment is to enabling multiple VNFs on a single server. In this case, all functions are deployed in one box.

The 5G network topology and the connectivity between the different network elements are implemented in a way that the CP and UP follow different paths. This implementation is called Control and User Plane Separation (CUPS) and follows the 3GPP standards to implement the distributed core functionalities. That kind of topology is also implemented in 5G EVE platform. The main benefit of this is to bring the UP core node near to the UE to reduce latency of the service and to offload the backhaul. This functionality can be associated with MEC capabilities of the network, like it was described in section 3.2.2

The 5G EPC supports the NSA 5G NR delivering end-to-end 5G use-cases and operates independently of access type, enables interconnection with all services to whatever resources they need, meeting different requirements for each use-case in terms of latency, battery life, data rates.

Traditional EPC contains many network elements and interfaces. However, in 5G EVE, EPC will be implemented on a single server that provides all the core functionalities. Therefore, the interfaces in EPC will be logical between different virtual machines and only physical connections will be towards the RAN (eNB and gNB) and the backhaul (switch). The New 5G Core Network included in the 5G system (5G CN), is defined to support data connectivity and services enabling deployments to use techniques such as e.g. Network Function Virtualization and Software Defined Networking. In 5GCN, as is described in 3GPP TS 23.501 [25], only User Plane Function has user data functionality. It is in charge just with data packets flows, not related to signaling or control procedures.

Network slicing is a new capability of the 5G network. It allows an operator set up multiple virtual slices of the RAN, core and transport networks to meet specific service requirements, e.g. radio access technology, bandwidth, end-to-end latency, reliability, guaranteed / non-guaranteed QoS, security level. The Network Slice Selection Function (NSSF) in the 5G system maintains a list of the Network Slice instances defined by the operator, including their definitions, such as required resources.

The slices are selected based on Network Slice Selection Assistance Information, each Network Slice Selection Assistance Information (NSSAI) identifies a group of slices. One single slice from the group is identified by Single Network Slice Selection Assistance Information (S-NSSAI), which contains two components, the Slice/Service Type (e.g. eMBB, URLLC, MIoT) and optional Slice Differentiator. The NSSF selects the set of Network Slice instances serving the UE (see Figure 41), identifies the Allowed NSSAI, determines the Configured NSSAI and mapping to the Subscribed S-NSSAIs. Also, it determines the AMF Set to be used to serve the UE, or, based on configuration, a list of candidate AMF(s), possibly by querying the Network Repository Function (NRF). A UE may be configured with a list of subscribed Network Slices and can request these during the registration procedure. Maximum 8 S-NSSAIs can be handled by one UE at the same time. The Access and Mobility Management function (AMF) will authorize the use of the Network Slices using subscription information from the Unified Data Management (UDM) or by a query to the NSSF. Here under is depicted the flow of slice selection:

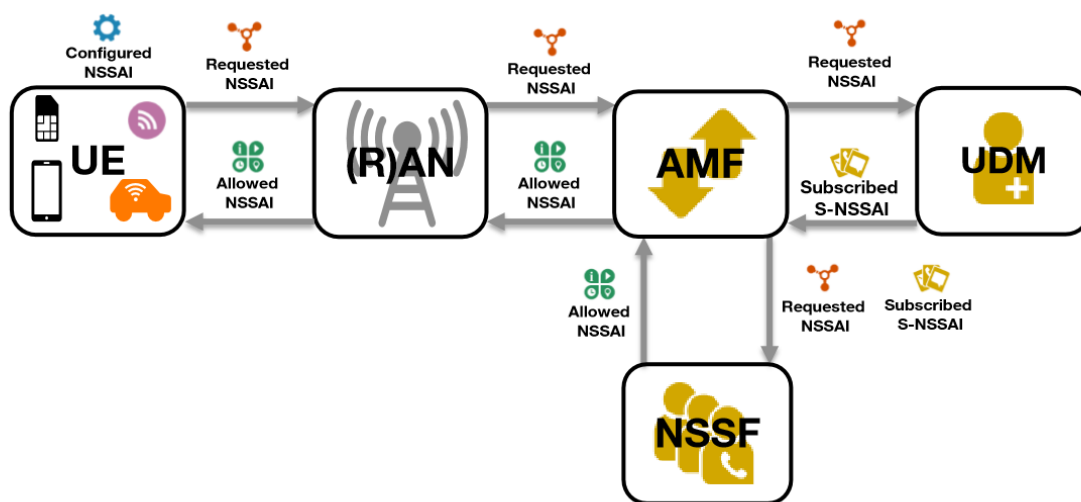

Figure 41: Slice Selection

Different solutions/technologies are used in different 5G EVE sites implementing 5G EPC NFs. Ericsson Proprietary Solutions are used in Spain, Italy and Greece whereas there are plans to integrate Nokia Proprietary Solutions in Spain and France; and plans to integrate OpenAirInterface (OAI) in France too.

4.2.3 SDN Controller

Virtualized network functions allow networks to be agile and capable to respond automatically to the needs of the traffic and services running over it. Slicing requires the partitioning and assignment of a set of resources that can be used in an isolated, disjunctive or shared manner. A set of such dedicated resources can be called a slice instance. Examples of resources to be partitioned or shared, understanding they can be physical or virtual, would be: bandwidth on a network link, forwarding tables in a network element (switch, router), processing capacity of servers, processing capacity of network elements. By abstracting physical resources, SDN enables to create “soft partitions”, allowing an easier (re-)grouping and (re-)programming, including the ability to provide service guarantees/SLA while making the best use of shared resources.

SDN principles have already been described in section 3.2.3. In 5G EVE platform, along all site facilities, we can identify SDN-based network control solutions on radio and transport domains, intra and inter-site backhaul. Inside the core network, due to vEPC-in-a-box architecture, the internal communication between VNFs and external communication with other systems are controlled via Site Router using static routes, VLANs and Open Shortest Path First (OSPF), Border Gateway Protocol (BGP), Bidirectional Forwarding Detection (BFD) network protocols. In the future, it is possible to use BGP/Multiprotocol Label Switching (MPLS) instead of VLAN for network separation. The Site Router can prioritize the traffic using QoS mechanisms like classification and marking, rate-limiting, queuing and scheduling. Traffic classification is based on the DiffServ model and IP packets are marked with a DSCP value. A DSCP value is configurable for most traffic by virtual EPC VNFs.

In 5G EVE platform, Radio SDN controllers based on OpenDaylight solution are installed in France whereas Transport SDN controllers based on ONOS solution is installed in Spain.

4.3 Management and Orchestration layer

MANO takes care about all the activities starting from initial deployment of the services (use-cases) that consists of both PNFs and VNFs.

When providing an end to end communication service, the network may use non-3GPP parts (e.g. Data centre network (DCN), Transport network (TN)) in addition to the network components defined in 3GPP. Therefore, to ensure the performance of a communication service according to the business requirements, the 3GPP management system has to coordinate with the management systems of the non-3GPP parts (e.g., MANO system) when preparing a Network Slice instance for this service. This coordination may include obtaining capabilities of the non-3GPP parts and providing the slice specific requirements and other requirements on the non-3GPP parts. Figure 42 illustrates an example of the coordination with management of TN part (e.g., directly or via MANO system).

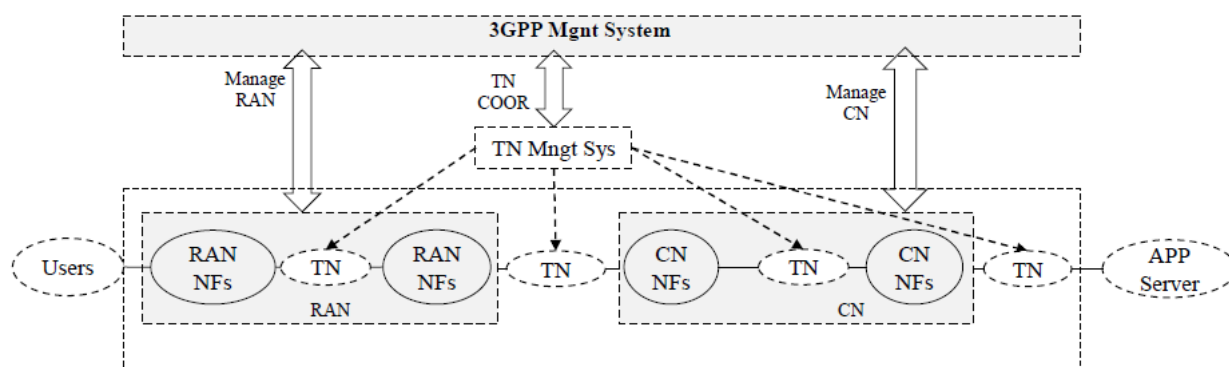

Figure 42: Example of coordination between 3GPP and TN management systems [45]

The 3GPP management system identifies the requirements on involved network domains, such as RAN, CN and non-3GPP parts of a slice by deriving them from the customer requirements to the services supported by the Network Slice. The derived requirements are sent to the corresponding management systems. The

coordination may also include related management data exchange between those management systems and the 3GPP management system.

As described in section 3.2.1, in 5G EVE, the 3GPP management role is represented by the 5G EVE portal and I/W Framework functions in the Interworking Layer used by the *Experiment Developer* to compose the ExpD and the NSD associated to the experiment. *Site manager* ensures during the Experiment preparation phase that AN and/or CN NFs not virtualized (PNFs) and transport network is prepared to inter-connect NFs described in the NSD. NFV was described in previous section 3.2.3, and we will focus more on the NFV MANO working domain next.

NFV Management and Orchestration (MANO) is one of the key technology layers used in 5G networks to automatize a process of the life-cycle management (LCM) operations of Virtual Network Functions (VNFs). NFV MANO is a Framework developed by a dedicated Working Group within the European Telecommunications Standards Institute (ETSI) and Industry Specification Group for NFV [46].

The 3GPP management system shall be capable to consume to NFV MANO interface (e.g. Os-Ma-nfvo, Ve-Vnfm-em and Ve-Vnfm-vnf reference points).

Producer of management services can consume management interfaces provided by NFV MANO for following purposes:

- NS LCM (Lifecycle Management).
- LCM VNF, Performance Management (PM), Fault Management (FM), Configuration Management (CM) on resources supporting VNF.

Figure 43 illustrates the interfaces between 3GPP management network and NFV-MANO framework. The NM and EM in Figure 43 are both logical functions.

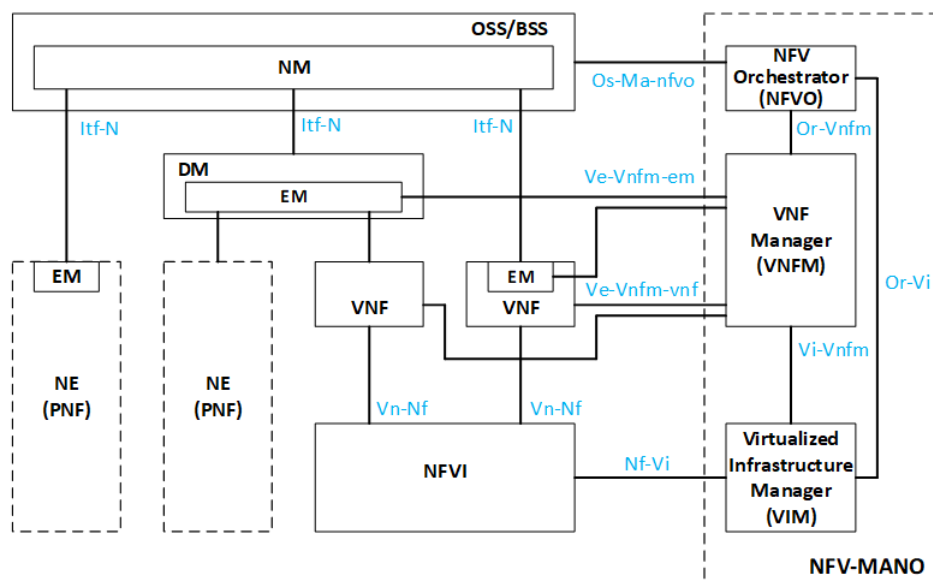

Figure 43: Mixed network management mapping relationship between 3GPP and NFV-MANO architectural framework [45].

Virtual Network Function’s Management and Orchestration includes classical functions (i.e. FCAPS), like: Fault Management, Configuration Management, Accounting Management, Performance Management and Security Management. There is also a novel range of management functions available, introduced as a consequence of Network Function Virtualization (NFV) approach, characterizing with decoupling of Network Functions from its physical infrastructure, and focused on the creation and lifecycle management of the necessary virtualized resources for the VNF.

The NFV-MANO architectural framework identifies the following NFV-MANO functional blocks also mentioned in section 3.2.3:

- NFV Orchestrator (NFVO): which has two main roles: the orchestration of NFVI resources across multiple VIMs and the lifecycle management of Network Services.
- VNF Manager (VNFM): The VNF Manager is responsible for the lifecycle management of VNF instances.
- Virtualised Infrastructure Manager (VIM): responsible for controlling and managing the NFVI compute, storage and network resources, usually within one operator's Infrastructure Domain.

The major role of NFV orchestrator is the responsibility for making decisions about executions of specified process and automated sequencing of activities, tasks, rules and policies needed for creation, modification, removal of network application, infrastructure services or resources. Management and orchestration can be applied to both virtualized and non-virtualized resources, where:

- Management and orchestration of virtualized resources should be able to handle NFVI resources (e.g. in NFVI Nodes) in NFVI Points of Presence (NFVI-PoPs).
- Management of non-virtualized resources is restricted to provisioning connectivity to PNFs, necessary when a NS instance includes a PNF that needs to connect to a VNF, or when the NS instance is distributed across multiple NFVI-PoPs or Network Point of Presence (N-PoP)s.

Os-Ma-nfvo reference point is used for exchanges between OSS/BSS (5G EVE portal in 5G EVE architecture) and NFV Orchestrator (I/W framework MSNO in 5G EVE architecture), and supports the following:

- Network Service Descriptor and VNF package management.
- Network Service instance lifecycle management.
- VNF lifecycle management.
- Policy management and/or enforcement for Network Service instances, VNF instances and NFVI resources (for authorization/access control, resource reservation/placement/allocation, etc.).
- Querying relevant Network Service instance and VNF instance information from the OSS/BSS.
- Forwarding of events, accounting and usage records and performance measurement results regarding Network Service instances, VNF instances, and NFVI resources to OSS/BSS, as well as and information about the associations between those instances and NFVI resources, e.g. number of VMs used by a certain VNF instance.

It is worth noting that during the VNF Management Lifecycle, VNF Management functions may monitor performance (based on KPIs of a VNF) as well as scale operations depending on information included in the deployment template (i.e. relevant parameters regarding KPIs or scaling). Scaling may concern changing a configuration of the virtualized resources (examples: scale up e.g. add CPU, scale down, e.g. remove CPU), adding new virtualized resources (scale out, e.g. add a new VM), shutting down and removing VM instances (scale in), or releasing some virtualized resources (scale down).

The VNF Management performs corresponding services by maintaining the virtualized resources that support the VNF functionality, without interfering with the logical functions performed by the VNFs. These functions are exposed in an open, commonly known abstracted manner serving as services for other functions. Services provided by VNF Management can be consumed by authenticated and properly authorized NFV management and orchestration functions.

5G EVE project offers a multi-site platform which consists of four independent sites delivered by different providers (partners): Greek, Spanish, French and Italian. As described in section 3.2.1, Network Service supported by a Network Slice could be a composition of other nested or concatenated NSs, each provided by different providers, or sites in this case (see Figure 44). In 5G EVE architecture, MSNO in the Interworking layer can delegate to lower-level NFVOs or local orchestrators in the different sites the management of nested NSs.

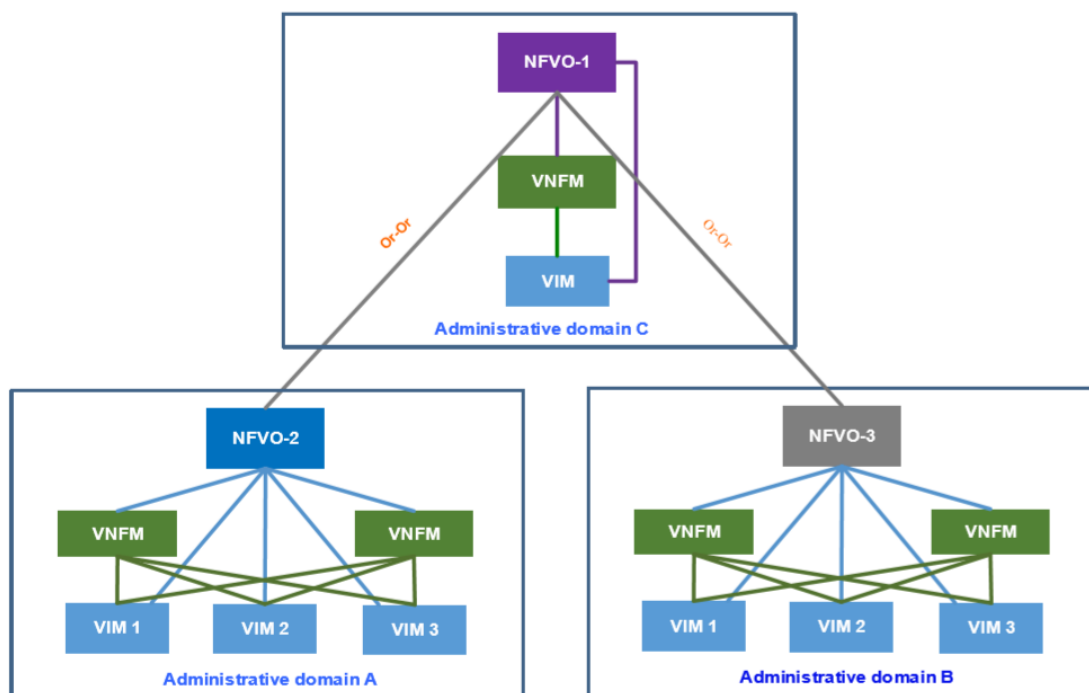

Figure 44: NSs provided using multiple administrative domains [47]

The provider NFVO needs to provide:

- A subset of the NSD management interface over Or-Or reference point which includes an operation of NSD query.
- NS performance management interface over Or-Or reference point.
- NS fault management interface over Or-Or reference point.

The consumer NFVO needs to provide:

- NS lifecycle operation granting interface over Or-Or reference point.
- NS instance usage notification interface over the Or-Or reference point.

In context of VIM implementation various solutions could be distinguished: a container-based Kubernetes or OpenShift and virtual-machine based OpenStack. Each of the 5G EVE partner can select among different VIM platforms according to their use-case needs. The differentiation mainly depends on a use-case requirement - whether the VNFs are based on containers or a virtual machine.

In 5G EVE Platform there are four Sites, which constitute four different smaller testbeds. Each Site is managed by different MANO implementation that is called in the project as a “local orchestrator”. Two MANO implementations are used: Open Source MANO (OSM) and Open Networking Automation Platform (ONAP). Both ONAP and OSM can orchestrate VNFs and supervise PNFs. Local Orchestrators in Spain and Italy are based on OSM solution, whereas local orchestrators in France and Greece facilities are based on ONAP. In addition, there are plans to Ericsson Proprietary solutions orchestrators also in Spain and Italy.

4.4 Interworking layer

5G EVE platform is composed by four sites with different infrastructure technologies, features and capabilities. 5G EVE platform offers a single-entry point to the experimenter where information for each single site can be retrieved and so, be used to design, deploy, execute, monitor and analyse the experiments. This single point is the 5G portal, and the feature of the 5G EVE platform that allows the user to access information of the different sites’ capabilities using a common information model and structure is the Inter Working Framework (I/W Framework)

I/W Framework is therefore the layer under Service Layer 5G EVE platform (materialized in the 5G EVE portal), that allows 5G EVE platform to work as a single platform service using a multi-site infrastructure through a unified and site-agnostic language (information model) towards the upper layers in the 5G EVE architecture. I/W Framework abstracts to upper layer in the 5G platform architecture the site-specific solutions adopted and supporting the experimentation process.

I/W Framework has hence two main functions in the 5G EVE platform architecture:

- To Upper Layers, unified and single format visibility of 5G capabilities, features and services offered by all 4 sites.
- To Lower Layers: add-hoc site-level solutions to expose site-specific 5G capabilities, features, and services to 5G EVE platform.

This directly connects to the two main reference points of I/W Framework within 5G EVE platform as shown in Figure 45:

- Interworking API in the NBI (North-Bound Interface) towards the 5G EVE experiment portal (service layer) used by the *Experimenter* to access the platform to plan and execute their experiments.
- Adaptation Layer in the SBI (South-Bound Interface) towards the different sites for management, orchestration and monitoring of network services offered.

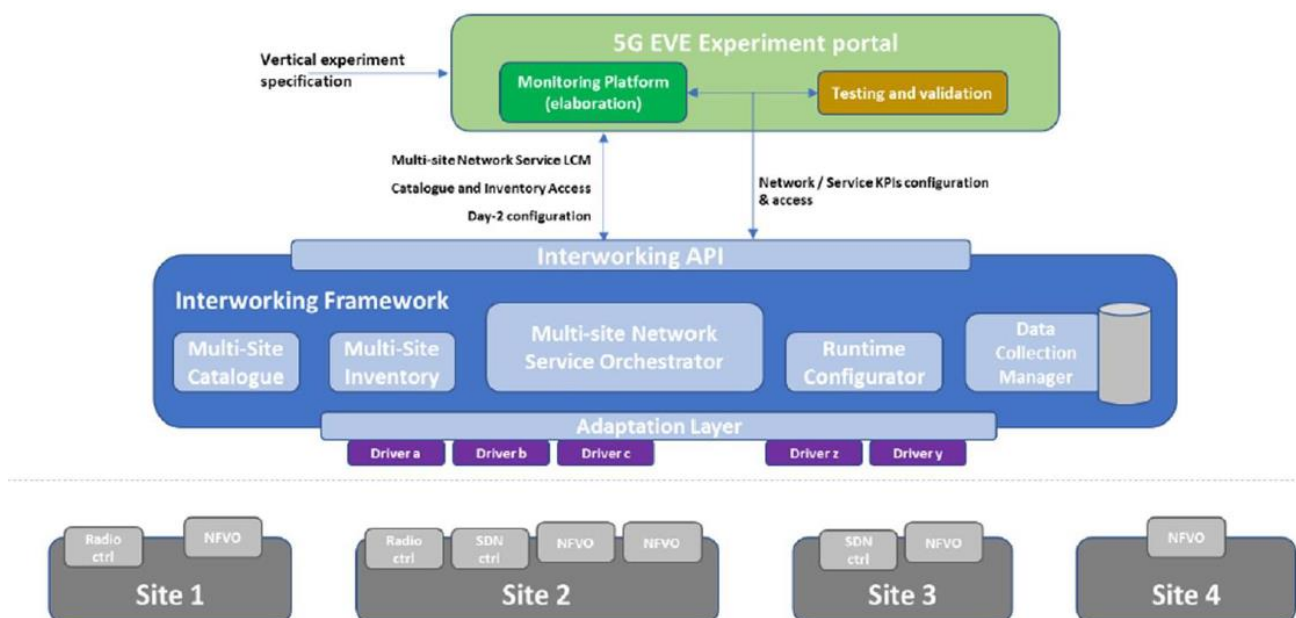

Figure 45: I/W Framework Upper/Lower Layers

In 5G EVE project, Interworking Reference model will be implemented in two phases.

- I/W Framework first implementation finished by M16, and aligned to Objective 4 of 5G EVE project, providing high throughput interconnections between 5G EVE sites and allow the execution of concurrent multi-site multi-slice experiments.
- I/W Framework’s second implementation planned for M24 and delivering a fully functional implementation of I/W Framework as described in this chapter.

5G EVE platform I/W Framework architecture solution for the first release (M16) introduced the following functionalities helping to support the preparation, execution, and monitoring of the experiments:

- Local NFVO components will be exposed to the Multi-site Network Orchestrator I/W Framework Module (MSNO). It is up to local orchestrators at this stage, to maintain direct control over the local

infrastructure, with other local components like VIMs, SDN controllers, that will not be exposed directly to the I/W Framework layer.

- Monitoring and testing tools available on each site will be exposed to I/W Framework.

5G EVE I/W Framework is composed of five modules, with the following summarized functionalities:

- The Multi-site Catalogue, Multi-site Inventory and Multi-Site Network Orchestrator (MSNO) are responsible for the management of the lifecycle of the deployed components, jointly allowing for multi-site slices supporting Verticals' experiments.
- The Runtime Configurator applies the required Day2 configuration to the provisioned VNFs and PNFs. The Data Collection Manager collects the required performance metrics to ensure the correct operation of the infrastructure and to validate the targeted KPIs.

4.4.1 Multi-site Catalogue

The Multi-site Catalogue maintains the relevant set of descriptors and deployment information required by the I/W Framework (in particular by the MSNO) for managing the lifecycle of the multi-site services and slices in support of the multi-site *Vertical* experiments. The Multi-site Catalogue NBI is the main entry point for on-boarding new multi-site Network Service Descriptors and querying available VNF Descriptors for enabling the 5G EVE Portal to compose and define multi-site experiments.

The Multi-site Catalogue can keep track of dependencies, restrictions, and capabilities of each 5G EVE site facilities, as required for deciding where to deploy a given Network Slice in support of a specific vertical use case experiment.

4.4.2 Multi-site Inventory

The Multi-site Inventory is the counterpart of the Catalogue component for what concerns the information on provisioned and instantiated Network Slices in the 5G EVE end-to-end facility. It is fully managed, in terms of information stored, by the Multi-site Network Orchestrator, and it maintains detailed information of running.

It exposes at its northbound reference point a set of APIs for retrieving runtime information related to deployed vertical experiments. Network Service and VNF instances provisioned in the site facilities in support of single- and multi-site *Vertical* experiments are maintained in the Multi-site Inventory. They are also offered to the Portal for visualization purposes, as well as for enabling re-use and sharing of existing services and slices among different experiments.

4.4.3 Multi-site Network Orchestrator (MSNO)

The Multi-site Network Orchestrator (MSNO) is responsible for coordinating the lifecycle of Network Services across the site facilities, leveraging on the local site orchestration components, and thus allowing for end-to-end Network Slices supporting verticals' experiments.

MSNO uses the resources exposed by the participating sites via the SBI to deploy the NS Instances that comprise a Network Service Instance.

MSNO will deal with composite NSDs by decomposing them in several connected nested NSD. The resulting single-NFVO NSDs are then sent to the Adaptation Layer for deployment on local NFVOs, across multiple sites if applicable.

For the expansion of composite NSs across multiple administrative domains, NFV-IFA 030 [48] specifies the functional requirements, interfaces, and operations to support the provision of network services across multiple administrative domains based on the interactions between NFVOs over the Or-Or reference point.

The main features offered by the Adaptation Layer API to the I/W Framework are the following

- Retrieving information about managed local NFVOs and their capabilities.
- NSD on-boarding to local NFVOs' catalogues.

- NSD management on local NFVOs' catalogues.
- VNFD and PNFD retrieval from local NFVOs' catalogues.
- Subscription to receive notifications about local NFVOs' catalogues updates.
- Lifecycle Management of Network Service Instances (NSIs).
- Subscription to receive notifications about local NFVOs' running NSI updates.

MSNO communicates with the local NFVOs at the 5G EVE sites for the expansion of composite NSs across multiple administrative domains. 5G EVE implementation of this communication is based on NFV-IFA 030 [47] which has started the specification of a reference point that ensures the interoperability of NFVOs in such scenarios. This reference point is called Or-Or, and although its specification is still in an early stage, it will be the basis for the communication of the MSNO with the local NFVOs at the 5G EVE sites.

4.4.4 Runtime Configurator

As previously described, MSNO is responsible for coordinating the lifecycle of Network Services across the site facilities supporting verticals' experiments. We call Day0/1 configuration those resulting from the instantiation and activation of the Network Slices conforming to the network service being used by the experiment execution.

Within 5G EVE, Runtime Configurator module in the I/W Framework allows changing in the experiment certain configuration parameters (Day2 configurations) to run the experiment again in different conditions without re-instantiating the slices.

The Runtime Configurator allows applying tailored runtime configurations to the provisioned end-to-end Network Services and VNFs in support of the vertical use case experiments. While MSNO can handle Day0 and Day1 configurations during the Network Services and VNFs instantiation phases (i.e. by enforcing them through the per-site exposed NFV Orchestration VNF configuration services), experiment specific and vertical oriented Day2 configurations can be applied through the interworking API via a common interface exposed towards the 5G EVE experiment portal. This requires that each site facility, in turn, exposes such capability for Day2 VNF configuration.

Two main operations will be offered by the Runtime Configurator component: (i) provision of extra configuration to VNFs and PNFs in order to work properly during the test (e.g. the topics in which they have to publish the metrics data to be collected by the Data Collection Manager), and (ii) execute the specific steps defined for each test and apply this configuration in the VNFs and PNFs.

The data and information models to be used in the Runtime Configurator communications depend on the PNFs that sites exposed to the I/W Layer, and the type of deployed NSs and VNFs, but mainly it will be based on OpenSSH protocol.

4.4.5 Data Collection Manager

The Data Collection Manager is a key component within the I/W Framework, and it coordinates the collection and persistence of all those infrastructure and application performance metrics that are required to be monitored during the execution of experiments for testing and validation of the targeted KPIs.

On the one hand, through the Interworking API, for each experiment, it configures the performance metrics that have to be measured for validating the specific use case KPIs, using publish/subscribe mechanisms. On the other hand, this monitoring configuration is mapped, through the proper logic provided by the Adaptation Layer, into a request for selective collection of network and service-related metrics to the involved 5G EVE sites. In this way, only the metrics needed to validate the KPIs required by the vertical will be monitored in each of the involved site facilities and collected by the Data Collection Manager for their storage in a common database and their delivery to the 5G EVE Experiment Portal.

The Data Collection Manager northbound API is the interface with the 5G EVE Experimentation Portal in charge of providing the metrics, KPIs and results to be collected and monitored within the Portal with the corresponding tools

4.4.6 I/W Framework Requirements on Sites Capabilities

Within 5G EVE, the following site capabilities will be exposed with that purpose:

- RAN selection and configuration: Dynamic selection and configuration of the Radio Access Network (e.g. for allocation of radio resources).
- Edge Computing: Advertisement of MEC hosts and related capabilities. Management and allocation of virtual resources on MEC hosts.
- NFV / Slice orchestration: Provisioning and management of NFV Network Services and Network Slices, including:
 - On-boarding and queries of descriptors, VNF packages, and slice templates.
 - Provisioning, termination and query of VNF/NS/slice instances.
 - Explicit management of RAN, and EPC/5G Core instances.
 - Day 0, Day1, Day 2 VNF configuration.
- SDN-based network control (Optional): Programmability of the physical network in the transport and/or the radio domain, as exposed through SDN controllers.
- Monitoring: Tools and platforms for collection of monitoring data related to different kinds of metrics, with mechanisms for monitoring configuration, polling of metrics values, notifications, etc.
- Testing tools: Tools to emulate background traffic or mobile UEs for testing and KPI validation purposes.

Site Capabilities and functionalities above should be properly advertised and/or made available through programmable primitives to enable the coordination, orchestration, and monitoring of vertical-driven 5G experiments over the end-to-end 5G EVE facility. These capabilities and functionalities will be exported from the single sites (where they are defined and accessed through site-specific models and interfaces) towards the 5G EVE I/W Framework, where they will be abstracted and translated into the interworking reference information model. If necessary, the functionalities provided by each site facility will be internally coordinated, aggregated or decomposed in more complex or more atomic functions by the I/W Framework, to expose a unified set of features towards the 5G EVE experiment portal.

4.5 5G EVE portal (Service layer)

The 5G EVE Portal is the entity of the 5G EVE architecture that provides the access to the 5G EVE platform for the verticals and experimenters. Through the 5G EVE portal, the verticals/experimenters can define, execute, monitor the progress and the result of their experiments. The mechanism to define experiments in 5G EVE is designed to meet the expertise of the verticals (usually oriented to services and applications) and it does not require any specific know-how in terms of networking issues or infrastructure configuration (physical or virtual).

In fact, in 5G EVE Portal, the definition and configuration of experiments is facilitated through a set of pre-defined experiment templates (called Experiment Blueprints) that can be selected and further customized by the experimenters, as well as through an intent-based service modelling tool (See Section 5.1). The service-oriented requirements from the verticals are translated into a formal definition of the experiment in terms of vertical service and experiment settings that will run in the 5G EVE facilities to execute the experiment.

Along the Experiment life cycle, some functional components within the 5G EVE portal support the different 5G EVE actors (verticals, experiment developers, experimenters, site managers) across the design, preparation, execution and results analysis of the experiments, as depicted in Figure 46:

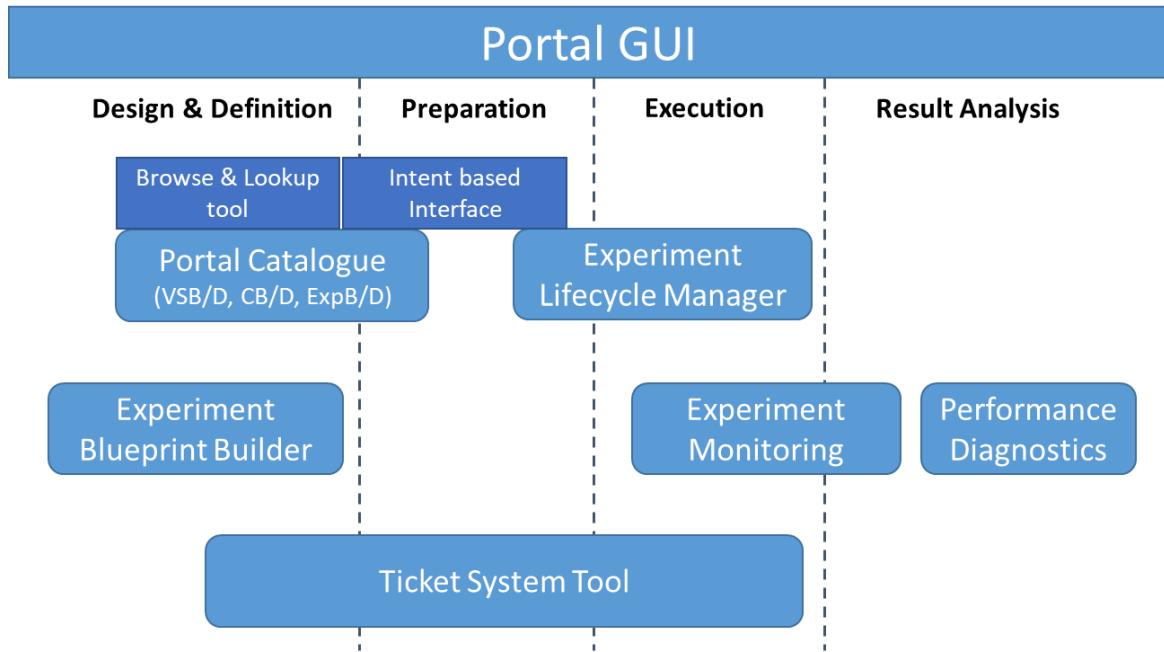

Figure 46: Major components of 5G EVE portal and their association to the experiment lifecycle

Next, we provide an overview of the functionalities implemented by each these tools/modules of the 5G EVE Portal.

4.5.1 Experiment Design Tools

The Experiment design tools are mostly involved in the Experiment Design and Definition phase of the experiment lifecycle, allowing the experiment developers to easily model new experiments. They include the following components:

Browse and Lookup Tool

The tool implements Graphical User Interface (GUI) for the Portal Catalogue, enabling the users to visualize all the elements needed to design and define an experiment: Blueprints and Descriptors from the vertical service and experiment context library, as well as the NSDs, VNFDs and PNFDs for their deployment, along with relevant information per item.

The information associated with the elements can be used as filter criteria for building a list of suitable items for the experiment, facilitating the navigation of the library and the selection of the desired experiment components.

Along with the visualization of the available elements, the Browse and Lookup tool offers a mechanism for the onboarding of the Blueprints and Descriptors, with embedded features for their content and format validation.

The access to the catalogue is regulated through a Role-Based Access Control (RBAC) mechanism, where the information and the elements visualized by the tool may vary according to the role of the authenticated user.

Intent-based Interface

The tool implements the functionalities to allow the users (i.e. experiment developers and experimenters) to easily define new experiment blueprints and configure them with specific settings using the natural language. This functionality, further described in section 5.1 as one of the main added value provided by the 5G EVE platform, is implemented through a web GUI where the users can describe the desired experiment in plain text and an “interpreter” that translates such description into ExpB and ExpD compliant with the experimenter request.

Experiment Blueprint Builder

It is a tool designed for the *Experiment developer* and it offers, through its GUI, a guided procedure for defining an ExpB. In particular, the *Experiment developer* can choose the components of the experiment (e.g. selecting the target site, the target service and the required execution contexts), complete the description of target KPIs and test cases and upload all the additional information needed to build the ExpB.

At first, the *Experiment developer* requests the creation of a new ExpB to the Experiment Blueprint Builder that, in turn, generates an empty ExpB item which will be filled step-by-step following the user's choices. In particular, the *Experiment developer* can associate to the ExpB a proper VSB and a number of CBs. These items can be selected from a list produced by the Experiment Blueprint Builder, which interacts with the Portal Catalogue for retrieving the relevant elements, based on filters generated following the user's indications.

Later, the *Experiment developer* has to define a proper NSD to associate to the ExpB, along with a set of translation rules for mapping different ranges of VSB/CB parameter values to a specific deployment of the given NSD. Such deployments are defined through "Instantiation Level" (IL) and "Deployment Flavour" (DF), where both IL and DF are fields belonging to the NSD.

Finally, the experiment developer will define additional details like KPIs to be measured or test script to run and, at the end of this final step, the ExpB is ready and can be onboarded. The developer can request the onboard through the tool interface.

Portal Catalogue

The 5G EVE platform includes two main catalogues: The Portal Catalogue and the I/W Framework Multi-site Catalogue. The Portal Catalogue resides on the Portal Backend and offers a centralized access point to all of the experiment components and information stored in the I/W Framework Multi-site Catalogue. Such information and components, which can be managed through the Browse and Lookup tool described before, are related to the whole platform, independently on the specific facility where the single entities can be deployed.

Thus, the portal catalogue offers a complete and centralized view of all of the experiment information stored in each site belonging to the 5G EVE platform. The most important features offered by the Portal Catalogue are:

- Coordination between the onboarding of experiment blueprints and the onboarding of the associated NSDs at the I/W Framework Multi-site Catalogue, as well as the continuous synchronization between the information maintained at the portal and at the I/W Framework Multi-site Catalogue.
- Validation mechanisms to guarantee the consistency between VSDs/CDs/ExpDs and the related blueprints during their onboarding.
- Mechanisms to retrieve NSDs (stored at the I/W Framework Multi-site Catalogue) associated with given blueprints during the processing of query requests.

4.5.2 Run Experiment Tools

Experiment Lifecycle Manager

The *Experiment Lifecycle Manager* is involved mainly in the Experiment Preparation and Execution phases and it is the centralized entity that coordinates all the procedures associated to the lifecycle of the experiment instances, from their creation, up to their scheduling, instantiation, running and, finally, termination.

In the preparation phase, it coordinates the scheduling procedure of a given experiment, which is created through the definition of its experiment descriptor ExpD by the experimenter. The tool creates a unique experiment identifier that can be used by the experimenter for retrieving information about the lifecycle state of the experiment. The scheduling procedure requires the interaction between *Experimenter* and *Site manager(s)* to agree on a suitable time slot. This interaction is mediated through the Ticketing System (described next), under the coordination of the Experiment Lifecycle Manager which maintains the up-to-date status of the experiment.

As discussed before, the Experiment Execution phase consists of two steps: instantiation and execution (run). The first step is triggered by the experimenter through the Portal GUI and consists of the setup of the *experiment virtual environment*, including virtual machines and virtual networks. Again, this procedure is coordinated by the Experiment Lifecycle Manager, which interacts with the I/W Layer Multi-Site Network Orchestrator

(MSNO). After the successful instantiation of the network service implementing the experiment, the Experiment Lifecycle Manager automatically triggers the execution of the experiment test cases. The trigger consists of a proper experiment request message the Experiment Lifecycle Manager sent to the *Experiment Execution Manager*, a module that is responsible for coordinating the different steps characterizing the execution of the test cases and the collection of the experiment results. When the experiment execution is completed, the virtual environment is terminated, and the resources released.

Ticketing System

The Ticketing System Tool is involved in all the phases that require an interaction between different 5G EVE actors, mediating their communication through automatic ticket notifications issued by the tool.

It is mainly used for message exchanging between the different actors involved in the experiment definition, preparation and execution, especially experimenters, site managers, and system administrators. In particular, the Ticketing System in 5G EVE handles the following type of message topics:

- *Errors/Warnings* notification concerning the normal operation of the 5G EVE Portal components. This functionality can be extended for including also other components of the 5G EVE platform (e.g. I/W Layer or site facilities).
- *Experiment Request Ticket* towards the site manager of the targeted 5G EVE facility and related answers to the experiment developers for the scheduling of an experiment.
- *VNF uploading advertisement*, once a VNF developer uploads in the system and the site manager needs to take care of its onboarding in its own site, upon validation of the VNF itself.

All the tickets described above are triggered automatically when a proper event (e.g. VNF uploading) occurs. In addition to such an automatic mechanism, all the 5G EVE actors may use the Ticketing System to manually create, update or delete tickets for notifying possible issues detected during the experiment lifecycle or to request assistance.

4.5.3 Experiment Monitoring Tools

The monitoring of the experiment KPIs as well as the collection of the results is entrusted to a proper toolset and performed during the Experiment Execution and Result Analysis phases, called **Experiment Monitoring and Maintenance & Results Collection** tool. Such toolset is, moreover, in charge of maintaining and manipulate the experiment data (performing data aggregation, processing, indexing, and storage).

The Experiment Monitoring tools allows collecting the monitoring metrics during the execution of the experiment, to elaborate them to build the KPIs for the validation of the service performance and, finally, to visualize the results of the experiment. The experiment monitoring is performed using different tools, as follows:

- *Data collection, aggregation and pre-processing tool*: it collects the data during the experiment execution from different and heterogeneous data sources: the data can be produced by the infrastructure (physical or virtualized) or even from the applications running during the experiment. Such data can be accessed through a mechanism based on the publish/subscribe functionalities (e.g. based on Kafka bus) and filtered based on the experimenter requirements. It also performs aggregation and pre-processing operations to the collected data.
- *Data indexing and storage tool*: the data is maintained in proper datastore internal to the monitoring facilities, allowing the experimenters to manipulate them, e.g. using indexing operations, providing a high degree of flexibility able to meet the different experimenter requirements. Additional post-processing and data analytics tools may be used to elaborate several customizable, vertical-specific KPIs and automatically evaluate them, e.g. on the basis of threshold values defined in the experiment descriptors.
- *Data visualization tool*: an experimenter can follow the evolution of the experiment by checking the status of the test-cases execution and the real-time variation of the selected KPIs. Such variation can be displayed in various forms (e.g. running diagrams) in the 5G EVE Portal.
- *Result analysis and off-line diagnostic*: once the experiment terminates its execution, the results of the various test cases are available on the portal, in terms of the number of tests executed, success/failure

percentages and so on. A diagnostic mechanism analyses such results and provides suggestions for improving the performance of the experiment as a whole or even of the single test cases.

For the implementation of the first three functionalities, the ELK stack [49] has been selected. In particular, the stack consists of three tools:

- Logstash: responsible for Data collection, aggregation and pre-processing.
- Elasticsearch: responsible for Data indexing and storage.
- Kibana: responsible for Data visualization.

As a complement, the ELK stack also provides an additional component, Beats, responsible for the collection of the data in the monitored VNFs and PNFs. KPI framework in 5G EVE platform is described in section 5.3.

5 5G EVE Platform - Added-values

5.1 Intent-based interface towards verticals

According to the Objective 5 (innovation objective) of 5G EVE, the main aim of the 5G EVE interface for the Verticals is “*to build an operational abstraction of the site facilities that provides vertical industries with a single operational interface towards the 5G end to facility.*” Such interface must address one of the main requirements the *Verticals* expect from the 5G EVE platform: the development of a set of APIs, tools, and mechanisms for easing the deployment of the experiments in a multi-site environment.

The Intent-Base mechanism perfectly fits with that requirement. In an Intent-Based Interface (IBI) humans (users, verticals) declare their “intent” to the platform (what they want or expect from the platform) by using an abstract language as close as possible to the natural one, without providing any specific technical configuration: it will be the platform to translate the provided intent in a set of actions needed for deploying the experiment as the *Vertical* expects to.

In this sense, for deploying an experiment, the *Vertical* does not require any knowledge concerning the platform or the different trial sites or networking in general. The IBI will collect and translate the intention of the *Vertical* in a predefined blueprint (in case blueprints matching the *Vertical* experiment intention) containing all the service’s requirements in terms of 5G networking configuration and infrastructure resources. Otherwise, it will return a message to the *Vertical* informing that such *Vertical* experiment intention does not exist in the platform yet.

The blueprint (VSB – *Vertical* Service Blueprint) translated from the *Vertical*’s intent represents the first step for the deployment of an experiment. Indeed, the entity that actually describes the experiment is represented by an Experiment Descriptor (ExpD). An ExpD is given by the composition of a *Vertical* Service Descriptor (VSD), consisting:

- A VSB filled with additional information needed to properly describe the characteristics of the target service,
- with a number of “context descriptors” (CD), which define further components needed to emulate an operational environment for the execution of the experiment,
- and finally, with a number of “test cases descriptors” (TCD) including parameters that could be set to different values along the different steps during experiment execution phase.

In 5G EVE, the IBI automatically builds an ExpD, composing the VSD by filling the information missing in the VSB, selecting the suitable CDs (second step) and building a number of TCDs that specify the execution steps.

The *Vertical* can trigger such a two-step process for deploying an experiment through the IBI’s Graphical User Interface (GUI), which offers two different ways for expressing the intents: *Free Text* and *Guided Selection*.

The *Free Text* intent format enables the Verticals to express their intents using the natural language. The so declared intent is analyzed by a specific translation tool that identifies specific keywords contained in the intent and maps them into specific fields of the blueprint. An example of Free Text intent is shown in Figure 47 where it is expressed, in natural language, the request of running an experiment concerning the Autonomous Guided Vehicles (AGV); “*I want to run an experiment with #2 AGVs in Greece from Spain*”.

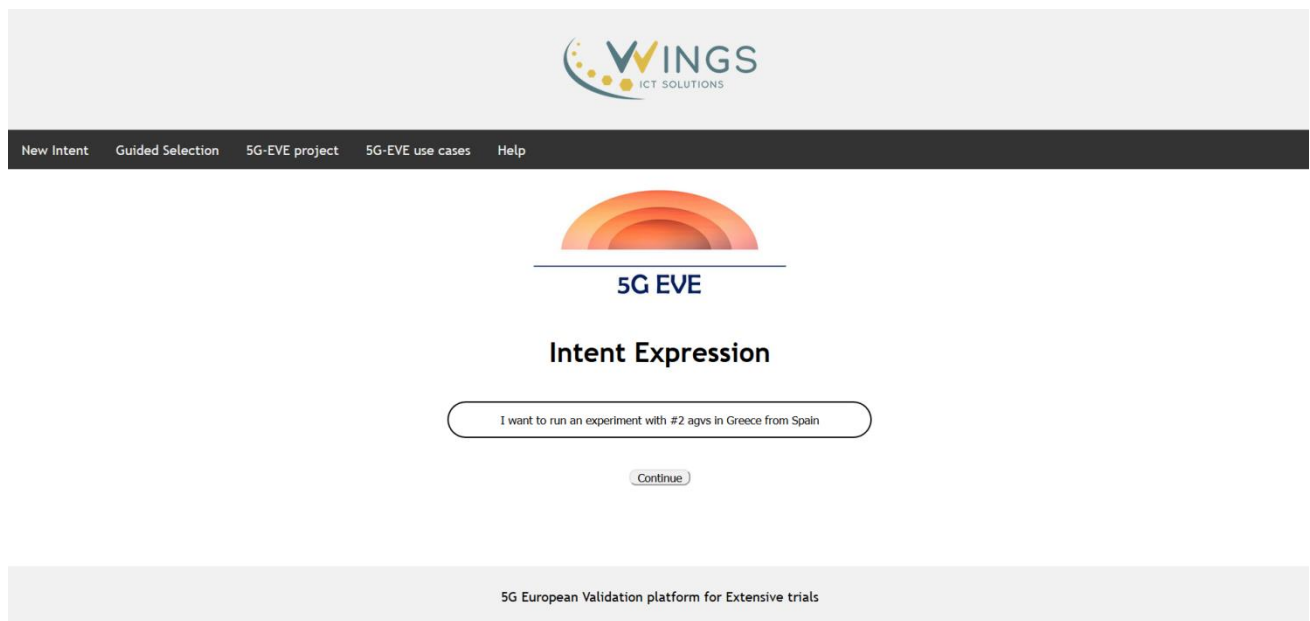

Figure 47: IBI GUI Intent based interface with an example of Free Text intent

After the translation process, there are two possible events that could occur and that require an action from the *Vertical*:

1. Blueprint with some empty field: the *Vertical* is requested to provide the missing information, as shown in Figure 48.
2. Invalid information provided in the intent: a message describing the problem is returned to the *Vertical* that can act accordingly.

The list of the keywords recognized by the translation process depends directly on the service provided by each 5G site facility.



Figure 48: Example of additional information requested to the *Vertical*

In the *Guided Selection*, the IBI GUI provides a Web Form that allows the *Vertical* for selecting an experiment among the available ones. Once the *Vertical* made his/her selection, the GUI provides him/her with the

information of the necessary fields to be filled for completing the process of expressing the intent, as shown in Figure 49 and Figure 50 respectively.



Figure 49: IBI Portal Guided Selection Interface

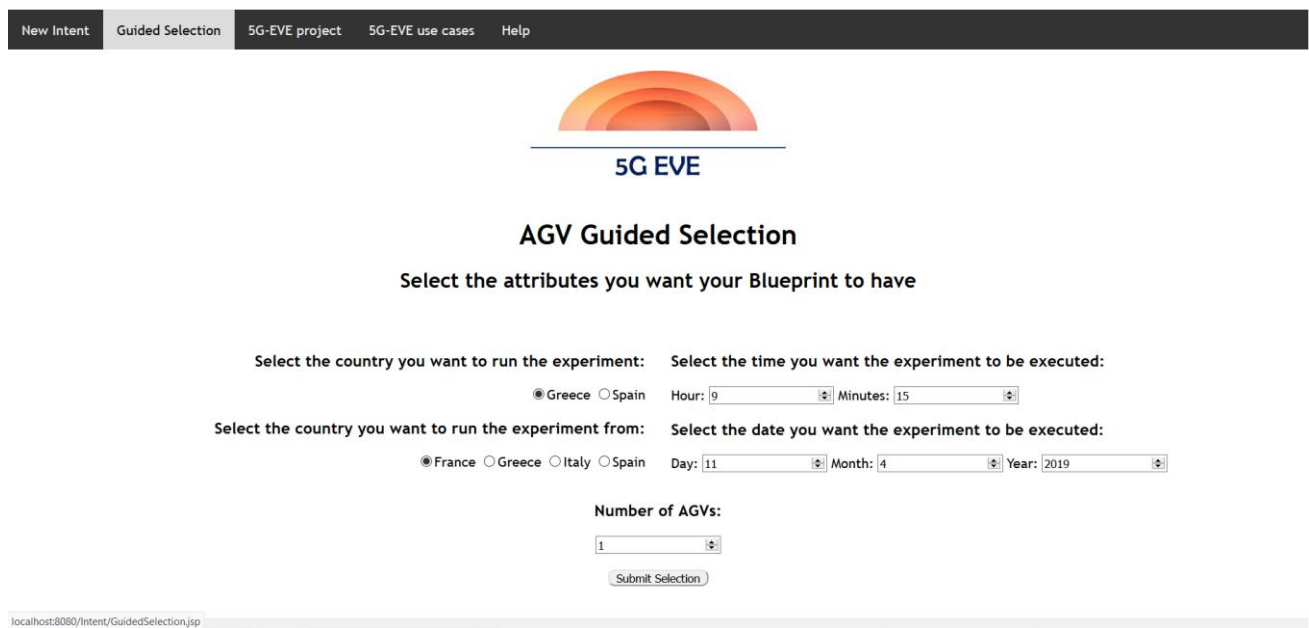

Figure 50: Example of fields to be filled for expressing the intent through the Guided Selection Interface

The IBI was designed and developed in the context of WP4. IBI architecture, blueprints, and descriptors for vertical services, contexts and experiments, as well as the state of the art and the standardization of the Intent-Based mechanism are described in detail in deliverable D4.1 [6]

5.2 Multi-site Multi-domain slicing and orchestration

Services that cross different sites and domains require the introduction of multi-site multi-domain slice and orchestration.

The Interworking (I/W) Framework located between the Experimentation Portal and the different sites is responsible to ensure the instantiation, management and orchestration of all the NFs needed to realize the NS designed in the Experiment.

The Core Network (CN) of 5G systems (5GC) is characterized by architecture modularisation: Control Plane (CP), User Plane (UP) separation and a Service-Based Interface (SBI). In Service Based Architecture (SBA), each NF, if authorized, can access the services provided by other NFs via the exposed SBI.

One important advantage of this architecture is the high flexibility to support E2E network slicing (already available in 4G EPC even if with some limitations). Slices can be defined as flexible E2E networks (or better, pieces of networks) customizable by both network operators and/or vertical industries as well, in terms of performance, capabilities, isolation, etc. Different 5G devices located at different 5G EVE sites will be able to access 5GC and requiring services from a plurality of supported Network Slices.

The lifecycle of a Network Slice can be split into four different phases:

- Preparation.
- Instantiation, Configuration and Activation.
- Run-time.
- Decommissioning.

In 5G EVE, *Experiment Developer* will map *Vertical* SLA requirements into an NSD that is stored in I/W Framework and that may include Network slice instance NSI(s) or Network slice subnet instance NSSIs from different sites, as previously described in this document in 3.2.1. Information of available NSIs/NSSI, VNFDs and PNFDs on each site is retrieved by Multi-site Network Orchestrator (MSNO) in the I/W Framework from the local NFVOs' catalogues. The MSNO communicates with the local NFVOs at the 5G EVE sites for retrieving this information to on-board the experiment NS and for the expansion of composite NSs across multiple administrative domains.

The M&O layer herein described needs to be extended in order to support multi-tenant and flexible E2E network slicing. The Network Slices have to be isolated between each other and capable to run on shared infrastructure without affecting each other. Local tenants manage the slices in their operative domains by means of local NFVO. Each tenant has its own NFVO that is responsible for resource scheduling in the tenant domain.

One of the main goals of 5G EVE project will be to achieve a multi-site slicing architecture but alternative simpler solutions will have to be implemented to support experimentation until the former will be completely supported by the platform.

The I/W Framework is a fundamental layer that is present independently of whether experiments are single-site or multi-site. In both cases, this layer is hiding the implementation details of each site from the 5G EVE Portal.

The high-level capabilities offered by the different sites to support single-site experiments are described in section 4.4 for the right functioning of I/W Framework and interaction with site Local Orchestrators.

Multi-site experimentation requires additional functionalities to which are required for single-site experiments. Multi-site Interworking Services include both connectivity services and access to KPIs from NFs that expand over multiple sites. For multi-site experiments, each 5G EVE site has to support specific functionalities to enable cross-site connectivity at the different planes and support Multi-site slices where NFs can be implemented in different sites within an experiment.

While the orchestration interconnectivity mostly targets the interaction of each site facility orchestration component with the I/W Framework itself, the cross-site connectivity at control (signalling data) and data planes (service traffic data) are key requirements for the execution of vertical use case experiments spanning multiple sites.

In 5G EVE, and leveraging on UCs technical requirements indicated in D1.1 [3] – Requirements definition and analysis from participant vertical industries, the following interworking services are defined to support multi-site scenarios:

- Orchestration Plane interconnection connectivity: Connectivity with the 5G EVE Interworking Framework from each site shall be established with a minimum availability of 99.9%.
- Control Plane Interworking connectivity: Low bandwidth performance but secure connectivity among sites for control traffic. Connectivity with other 5G EVE sites shall be established with an availability of at least 99.9% and 20 Mbps of guaranteed bandwidth.
- Data Plane Interworking connectivity: Secure connectivity among sites for user traffic. Low bandwidth performance experiments will employ best effort connectivity. High bandwidth performance experiments will employ a parallel high bandwidth low latency network. Connectivity with other 5G EVE sites with availability of 99.9%, 200 Mbps of guaranteed bandwidth (at least between a pair of sites) and the following maximum latency, per pair of sites:
 - Italy (Turin)- Greece (Athens) interconnection: 160 ms
 - Italy (Turin)- Spain (Madrid) interconnection: 110 ms
 - Italy (Turin)- France interconnection: 60 ms
 - Greece (Athens)- Spain (Madrid) interconnection: 240 ms
 - Greece (Athens)-France interconnection: 210 ms
 - Spain (Madrid)-France interconnection: 110 ms
- Multi-site Experiment Monitoring Support: Capability of translating the monitoring requirements defined by *Experimenters* (based on selected KPIs) to the sites taking part in the same experiment. Sites will typically have different local monitoring tools and mechanisms.
- Multi-site E2E Orchestration Support Operation: Capability to deploy the required slices, and VNFs hosted in the 5G EVE Catalogue on top of them, to the sites taking part in the same experiment. Sites will typically have different local orchestrators, controllers and network infrastructure.

Although the main idea behind the multi-site slice is to allow the interconnection of any VNF from any 5G EVE site, some restrictions have been established due to operation and maintainability reasons. Each 5G EVE Site network is operated as an independent network associated with a specific operator. For this reason, we will support the following composition of multi-site deployments:

- Access Network: the complete Access Network will belong to a specific 5G-Site. The end-to-end *Vertical* slice could include Access Networks from different sites but cannot define an Access Network expanded through several sites.
- Core Network: the core network can span through two sites using the standard roaming deployments, i.e., Local Break-Out or Home Routed, according to 3GPP TS 23.501 [25]. Note: this allows, for instance, one scenario with one UPF in HPLM and another in VPLM and so, using NFs in different sites.
- VNF in data network: VNFs belonging to the Data Network can be deployed in any of the 5G EVE sites without any restriction. For instance: a router, a firewall, a traffic generator, ...

Further information of Interworking services deployment implementation and technologies used can be found in D3.2 [50]

5.3 Performance Diagnosis (KPI Framework)

Connected to Innovation objective 6, one of the added-value of 5G EVE platform is a common methodology and testing Framework across 5G EVE E2E facility for KPI monitoring, benchmarking, evaluation and performance diagnosis. Details of Testing Framework within 5G EVE are described in D5.1 [18] and D5.2 [51], whereas performance diagnosis methodology and procedures will be reported in D5.5- Performance diagnosis mechanism (M24, June 2020), D5.6 - Performance diagnosis mechanism and reporting methodology document (M26, August 2020) and D5.9 - Testing, validation, and performance diagnosis methodologies user manual (M35, May 2021).

In the context of 5G EVE, the key performance indicators (KPIs) represent measurable parameters that provide meaningful performance information to the *Experimenters*, that is, the Verticals using the 5G EVE infrastructure. *Vertical* customers define services in an end-to-end fashion, where applications satisfy a given purpose with commercial orientation. Those services typically require the accomplishment of several technical KPIs particular to the service characteristics, usually defined by specific upper/lower values for certain parameters such as latency, bandwidth, etc. It is then essential for those vertical customers to properly define the KPIs of interest, as well as their intended values.

On the other hand, 5G infrastructures such as 5G EVE expand over different network segments encompassing different technologies such as radio, access/edge, transport/core, cloud, etc. The end-to-end scope of the service implies the need of mapping the end-to-end service KPIs to the different segments to understand the influence of each part, as well as to get insights of how each segment contributes to the overall budget for each specific KPI. Performance diagnosis is key for a practical evaluation of the cost of different services configuration in order to optimize the deployment of a commercial service. Sometimes the best performance cannot be achieved at any cost, so many different approaches must be evaluated to well understand the cost of some performance improvement.

5G EVE KPI Framework allows running the same tests under different environment/conditions and technologies. The forensic analytics tools provided by the service plus the vertical operator web service information will guide the operators to better understand the effects of test parameterization/configuration on the relevant KPIs and then start a virtuous cycle of use case improvement.

The following Figure 51 describes the interaction of different 5G EVE platform modules that form part in the KPI handling process, starting at the Experiment Execution phase of the 5G Experiment Flow.

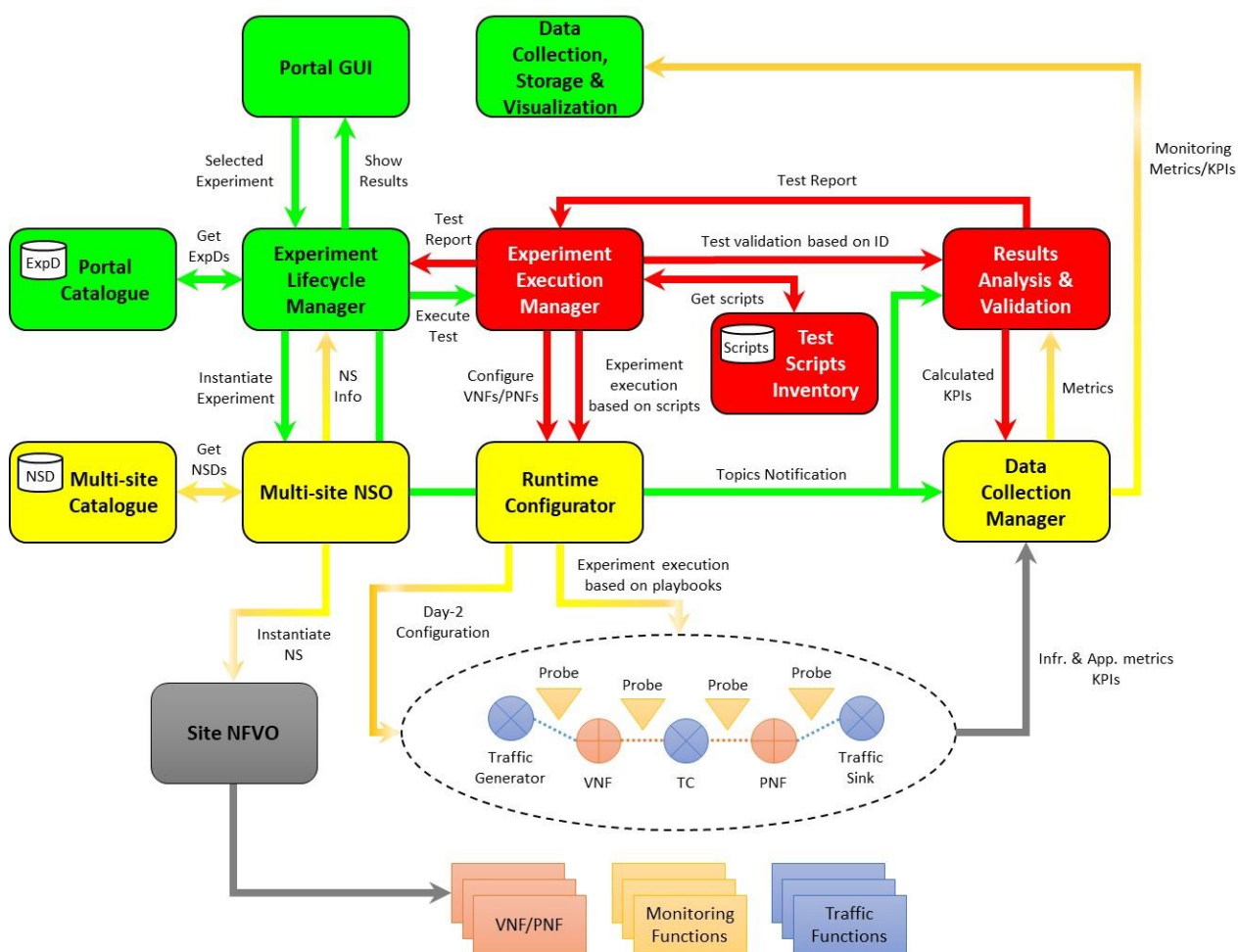

Figure 51: 5G EVE platform modules interaction - KPI handling process

Before Experiment Execution phase starts, Experiment Preparation phase has been completed. One of the outputs of this preparation phase is the ExpD, that, among other things, includes:

- List of KPIs (*Vertical*, Network,) to be collected and KPI targets that will be used to validate the experiment.
- Test Passing criteria: KPI targets/thresholds for the test to pass.
- Measuring method: what, how and where to measure each KPI
- Experiment / TCs external conditions or variables (e.g. the number of simultaneous users/devices, additional delay, background traffic,) that the *Vertical* may use to reproduce the production environment.

It is important to remind that within Experiment Preparation activities, KPIs included in ExpD that must be measured/collected in non-virtualized environment (for example: activation thru 3GPP management systems of network counters in 3GPP non-virtualized NFs), have been configured/activated in required PNFs.

During Experiment execution, the 5G EVE Portal "Experiment Lifecycle Manager" module sends a request to I/W Framework Module - MSNO to instantiate the experiment which includes the activation of KPIs in virtualized NFs. Furthermore, the "Experiment Lifecycle Manager" module interacts with the "Experiment Execution Manager" module that setups the external conditions required for the TCs associated with the experiment and contacts with Runtime Configurator in the I/W Framework to execute the scripts that configure these variables in the target NFs.

Experiment Lifecycle Manager publishes the topics related to the metrics, KPIs and results that are expected to be monitored related to experiment, in a string-list format, in the Data Collection Manager, where each string will be a unique identifier for the metric/KPI/result to be monitored. Components that perform functions related to monitoring and performance analysis like Results Analysis and Validation module, subscribe to the corresponding topics related to the experiment, depending on the specific experiment that is going to be executed and the metrics/KPIs/results to be monitored. The topics will be used in the delivery of the monitoring data for a given experiment. Monitoring data include metrics (data extracted from the monitored components in a given format), KPIs (formula to be applied for a set of metrics) and results (specific values related to the experiment, calculated from the metrics, which are interesting for experiment monitoring). Results Analysis and Validation module calculates the KPIs from the metrics collected by Data Collection Manager. Calculated KPIs are then published back from Results Analysis and Validation module to Data Collection Manager so that they can be visualized in the Portal. For more information, see D4.1 [6] and D5.2 [51].

Selected KPIs are displayed in the GUI for *Experimenter* live execution monitoring and once Experiment / TCs are concluded, 5G EVE platform facilitates to *Experimenter* a report including information of test passing result (PASS/FAIL result for KPIs) and a performance diagnosis report including information of potential bottlenecks and suggestions/recommendations/proposals to improve performance. All in all, the 5G EVE testing Framework tools can be grouped into the ones shown in the Figure 52.

Within 5G EVE testing Framework architecture, Monitoring tools in the 5G EVE portal capture KPI metrics from the Kafka broker (see Figure 53) of the "I/W Framework Module - Data Collection Manager " and "I/W Framework Module - Data Collection Manager " collects the KPI metrics from the Traffic Generation Tools and Network Functions which are pushed to a Kafka bus.

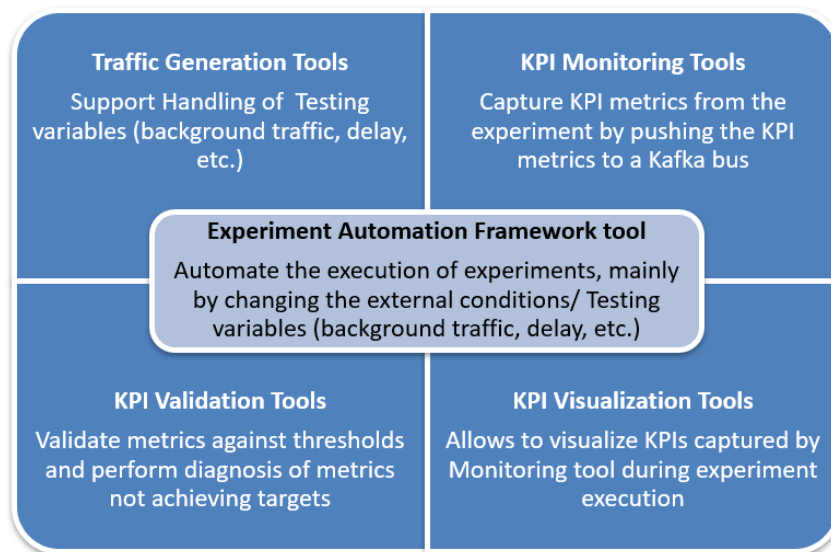

Figure 52: 5G EVE testing Framework tools

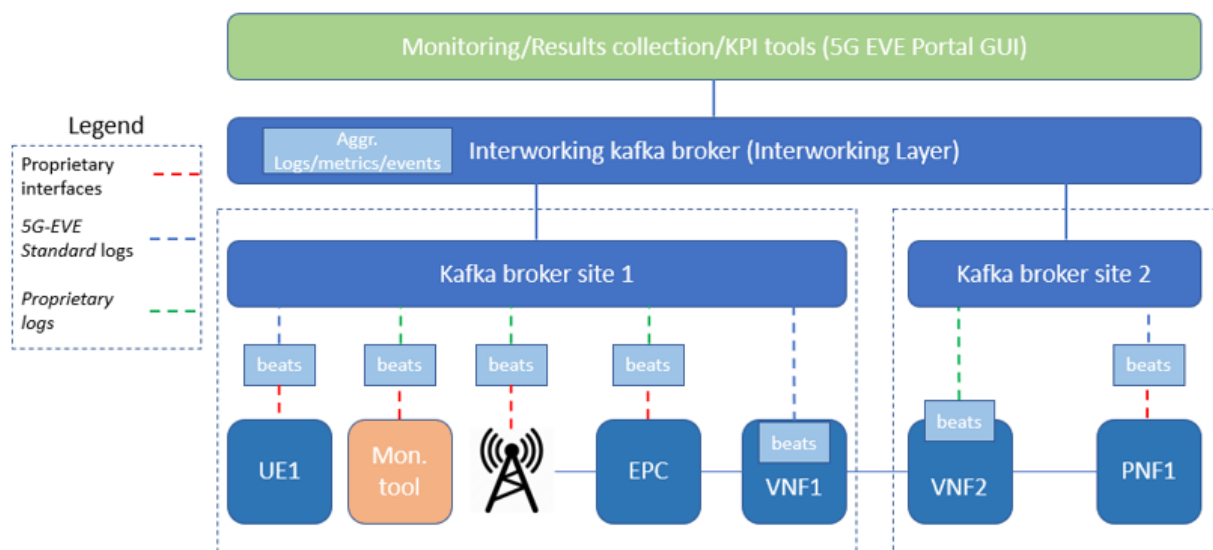

Figure 53: 5G EVE KPI sources and KPI collection interfaces [6]

These KPIs are exposed to KPI Visualization Tools in the 5G EVE GUI but also to KPI Validation Tools in the 5G EVE portal back-end (see Figure 54). KPI Validation Tools analyse the collected KPI metrics and generate the validation and performance diagnosis reports that are finally made accessible to *Experimenter* through the "Experiment Lifecycle Manager".

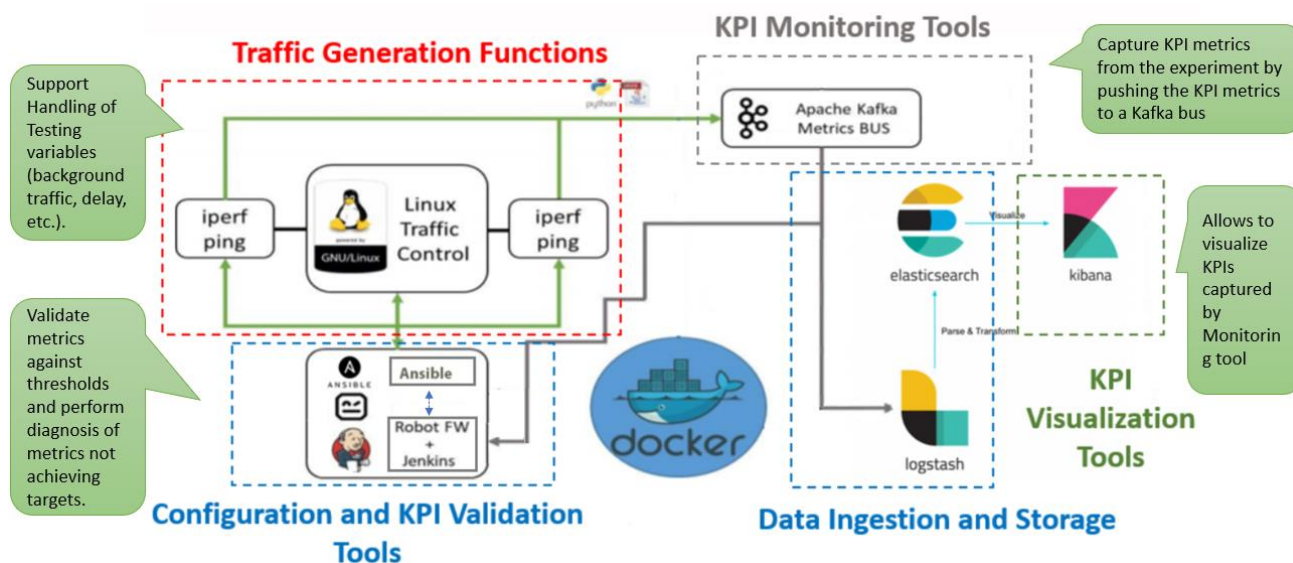

Figure 54: 5G EVE testing Framework tools components

5.4 5G VNFs (Openness Framework)

5G EVE provides a Multi-site Catalogue which is “responsible for storing and maintaining all the information related to the available Networks Services (NSs) and VNF”. This catalogue is considered as a core component not only because it contains the on-boarded VNFs and their associated descriptors to build Network Services and Network Slices, but also because it shall encompass some properties for every VNF and every Network Service:

- VNF Provider for every VNF, specifying the legal entity which is responsible for this VNF.
- Terms of Use, specifying which type of license is granted inside and outside the scope of 5G EVE and detailing all the third parties’ components with their associated licenses (this shall include open source software licenses).

This catalogue and the fact that it must include the terms of use is the guarantee that the 5G EVE Framework is open and can mix proprietary and open source components. At the catalogue upstream, it is every *VNF provider*’s responsibility to build a Continuous Integration/Continuous Delivery (CI/CD) process with a Development/Operations (DevOps) approach (combination of software Development and IT Operation teams) in order to keep the 5G EVE Multi-site Catalogue up-to-date with the VNF packages, their descriptors and their documentation under configuration management.

In order to ensure interoperability, every VNF shall be integrated in NFVO, meaning that first, VNFs must be compliant with the NFVO available at the site where the VNF package has to be onboarded and second, the VNF/VNFD have to be integrated and tested by the *VNF provider* prior to being considered as available in the catalogue. The challenge to support Cloud-Native Functions (CNF) shall be addressed by each local NFVO.

The Multi-site Catalogue and the NFVO are the pillars of the Openness Framework. It should be noted that the local NFVO (Open Source MANO, Open Networking Automation Platform (ONAP), ...) may differ from one site to another.

The list of VNFs in the catalogue includes:

- Radio Access Network VNFs and/or PNFs:
 - Open Source based, mainly on Open Air Interface Framework.
 - Supporting LTE for 5G NSA mode) and 5G NR.
 - Provided by vendors from 5G EVE telco infrastructure suppliers (Nokia, Ericsson).
 - Provided by other vendors (Amarisoft, ...).
- Core Network VNFs
 - Open Source based, mainly on Open Air Interface Framework.

- Supporting 5G EPC for 5G NSA mode and 5GC for SA mode.
- Provided by vendors from 5G EVE telco infrastructure suppliers (Nokia, Ericsson).
- Provided by other vendors (Athonet, ...).

As described in previous sections, during experiment definition phase, the blueprints are created by Experiment Developer. Once VNFs have been on-boarded, available VNFs stored in Multi-site Catalogue become visible at the 5G EVE Portal. ExpB (created by Experiment Developer) contains information on VNFs conforming the experiment and the associated Network Service Descriptor (NSD), as well as information used by the local NFVO for life cycle management of the NS which includes the composition of Network Functions (NF) as a part of this NS.

The Network Service will be composed of the VNFs mentioned above, and it will be the responsibility of the Experiment Developer to consistently set up the graph between VNFs, taking into various criteria: the interoperability between the VNFs, the mapping with the hardware, the licenses, etc.

Connected to Objective 8 of 5G EVE, 5G EVE platform supports a pool of optimized VNFs available in the Multi-site Catalogue which can be orchestrated in a modular way and which will give the possibility to add new VNFs to the pool, in order to validate novel and non-standard features. Note that VNFs available in the catalogue will not be limited to 5G System AN or CN network functions but will include additional VNF like video encoding/decoding/transcoding, probes, security, etc.

6 5G EVE platform - Dynamics

6.1 Interactions between 5G EVE users and 5G EVE platform

6.1.1 Experiment Design

As described in section 0 and fully detailed in D4.1[6], the experiment design phase is the phase where the experiment developers, site managers, and *VNF providers* interact with the platform to generate the blueprints and on-board VNF packages required to run the target experiment.

Figure 55 provides a high-level overview of the different functional entities, the actions performed, and the messages exchanged by each of the entities during this phase. D4.1 [6] includes further details of the messages exchanged in terms of purpose, internal information, and parameters.

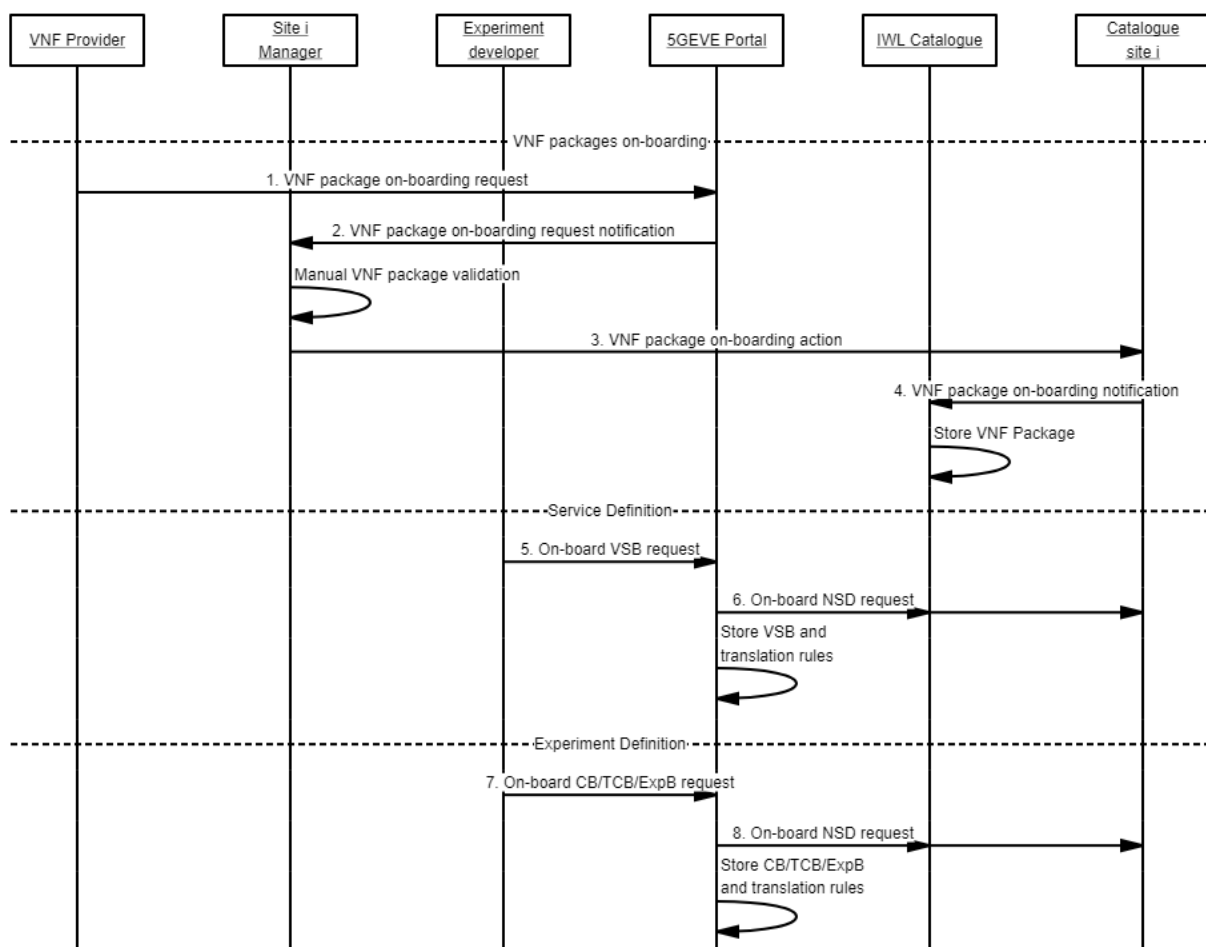

Figure 55: Experiment definition workflow

Table 8 includes for each message, a description and parameters used.

Table 8: Experiment definition messages

Id	Message	Description	Parameters
1	VNF package on-boarding request	Message issued by the <i>VNF provider</i> to request the on-boarding of a new VNF package.	VNF package URL, and the site where to on-board the VNFs. The package should contain at least the VNF images and the VNFD.
2	VNF package on-boarding request notification	This message notifies the <i>Site manager</i> about a new VNF package onboarding request.	The URL to the VNF Package of message 1, together with the information about the user issuing the on-boarding request.
3	VNF package on-boarding action	Message used by the <i>Site manager</i> to trigger the on-boarding of the VNF Package on his site.	The URL to the VNF Package of message 1.
4	VNF package on-boarding notification	Message issued by the site catalogue to notify the Multi-site Catalogue about the successful on-boarding of a new VNF package.	The URL to the VNF Package of message 1.
5	On-board VSB request	Message from the <i>Experiment developer</i> to the 5GEVE platform containing the vertical service definition.	The VSB (containing: the service parameters, the atomic components, etc), the translation rules, the NSDs and the selected site.
6	On-board NSD request	Message issued by the 5GEVE Portal to trigger the NSD on-board procedure at the sites by means of the Multi-site Catalogue.	The NSDs retrieved from message 5.
7	On-board CB/TCB/ExpB request	Message from the <i>Experiment developer</i> to the 5GEVE platform.	The CB/TCB/ExpB, the translation rules, the NSDs and the selected site.
8	On-board NSD request	Message issued by the 5GEVE Portal to trigger the NSD on-board procedure at the sites by means of the Multi-site Catalogue.	The NSDs retrieved from message 7.

6.1.2 Experiment Preparation and Execution

The experiment preparation and execution phases, as described in section 0 and fully detailed in D4.1 [6], are the phases where the experimenters themselves interact with the 5GEVE Portal to provide the missing service and experiment parameters, schedule an experiment run and retrieve the experiment results.

Figure 56 and Figure 57 shows a high-level description of the experiment preparation and execution workflows respectively. The messages used in these figures are further described in Table 9 and Table 10 respectively. Refer to D4.1 [6] for more fine-grained workflows and descriptions of the different pieces composing the overall workflow.

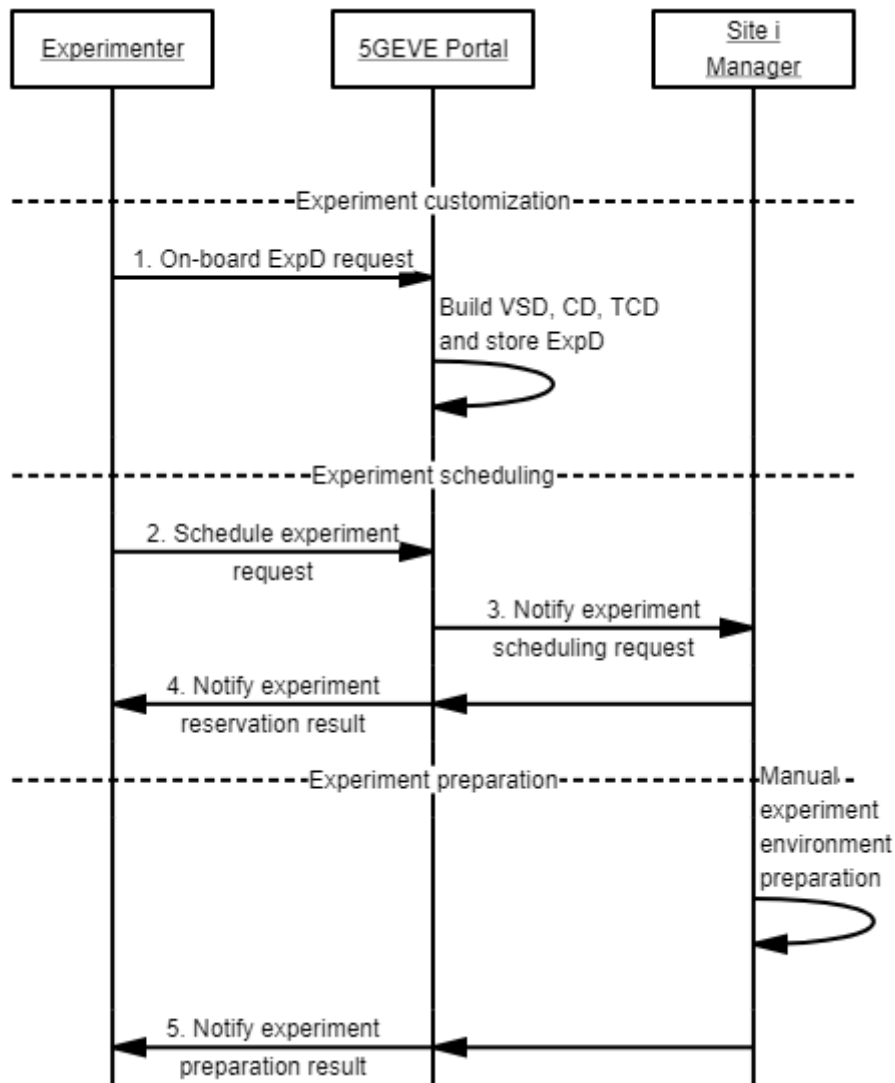

Figure 56: Experiment preparation workflow

Table 9 includes for each message, a description and parameters used.

Table 9: Experiment preparation messages

Id	Message	Description	Parameters
1	On-board ExpD request	Message issued by the <i>Experimenter</i> to provide the missing experiment parameters.	The experiment blueprint id, and values for the vertical service, context, and experiment parameters.
2	Schedule experiment	Message used by the <i>Experimenter</i> to request to schedule an experiment to the 5GEVE Portal in order to trigger the resource reservation the correspondent configurations.	The ExpD id, the desired date and time to run the experiment.
3	Notify experiment scheduling request	Notification from the 5GEVE Portal towards the <i>Site manager</i> to inform about the arrival of a new experiment scheduling request.	The ExpD id and the date and time requested in message 2.
4	Notify experiment reservation result	Message from the <i>Site manager</i> to the <i>Experimenter</i> (using the 5GEVE Portal as intermediary), to inform about the resource reservation.	The correspondent ExpD id, the date and time retrieved from message 2, the id for the experiment execution and the results of the resource reservation.
5	Notify experiment preparation result	Message from the <i>Site manager</i> to the <i>Experimenter</i> (using the 5GEVE Portal as intermediary), to inform about the results of the manual experiment environment preparation.	The correspondent ExpD id, the date and time retrieved from message 2, the id of the experiment execution and the results of the environment configuration.

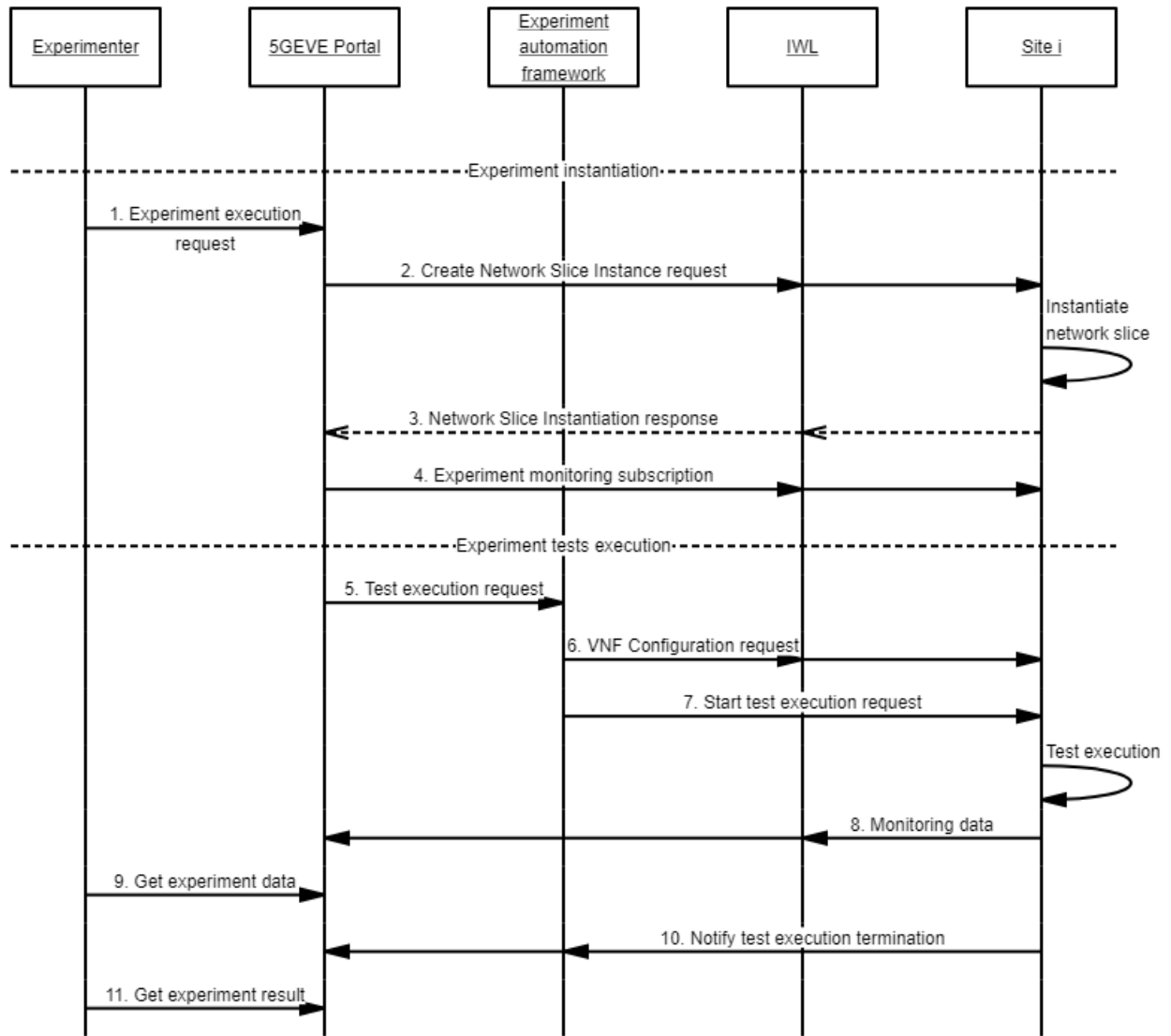

Figure 57: Experiment execution workflow

Table 10 includes for each message, a description and parameters used.

Table 10: Experiment execution messages

Id	Message	Description	Parameters
1	Experiment execution request	Issued by the <i>Experimenter</i> to trigger the experiment execution.	The experiment instance id.
2	Create Network Slice Instance request	This message is sent from the 5GEVE Portal towards the correspondent site, using the I/W Layer as mediator. The message contains the Network Slice Request obtained after applying the translation rules using the service, experiment and context parameters specified during the Experiment customization phase.	The parameters specified in ETSI GS NFV-SOL 005 [17] "Network Functions Virtualization (NFV) Release 2; Protocols and Data Models; RESTful protocols specification for the Os-Ma-nfvo Reference Point", for requesting the instantiation of the NFV Network Service associated to the Network Slice instance.
3	Network Slice Instantiation response	Message from the site towards the I/W Framework and the 5G EVE Portal informing about the Network Slice Instantiation result.	The parameters specified in ETSI GS NFV-SOL 005 [17] "Network Functions Virtualization (NFV) Release 2; Protocols and Data Models; RESTful protocols specification for the Os-Ma-nfvo Reference Point", for requesting the instantiation of the NFV Network Service associated to the Network Slice instance.
4	Experiment monitoring subscription	Message used by the 5G EVE Portal to subscribe to the I/W Layer monitoring platform to receive the experiment monitoring information. The I/W Framework shall in turn subscribe to site monitoring to also receive the information.	5G EVE D4.1 [6], "Experimentation Tools and VNF Repository"
5	Test Execution request	This message, from the 5G EVE Portal, triggers the execution of the experiment tests at the Experiment automation framework.	The message shall contain at least the test id and the Network Slice Instance Id obtained in message 3.
6	VNF configuration request	Message used by the Experiment automation framework to send VNF configuration parameters required by the experiment, using the I/W Framework and the site as intermediaries.	The message shall contain the VNF instance id, the Network Slice instance id, and the configuration parameters.

7	Start test execution request	Triggers the test script execution at the site. For the moment we are assuming single site test script executions.	The test script id and the Network Slice Instance id.
8	Monitoring data	During the experiment execution, the site will forward monitoring information to the I/W Framework (which in turn will forward it to the 5G EVE Portal).	Network Slice Instance and monitored item id and monitored item data.
9	Get monitoring data	During the experiment execution, the <i>Experimenter</i> can use this message to retrieve the experiment monitoring information.	The experiment instance id and the monitored item ids.
10	Notify test execution termination	With this message, the Site signals to the I/W Framework the finalization of the tests. The I/W Layer then forwards this message to the 5G EVE Portal.	The experiment instance id.
11	Get experiment result	Message used to retrieve the experiment report from the 5G EVE Portal.	The Experiment instance id.

6.2 Interfaces

In this section, we will introduce the description of the interfaces for the functional entities in order to support the workflows with the management and orchestration layer and the interworking layer.

6.2.1 Vertical and Experiment Developer Interfaces

The external verticals view of the project is defined in Figure 58, where the Verticals devices and application servers are connected to the 5G EVE platform as clients, while the testers are connected to the 5G EVE web portal to see the experimentation results.

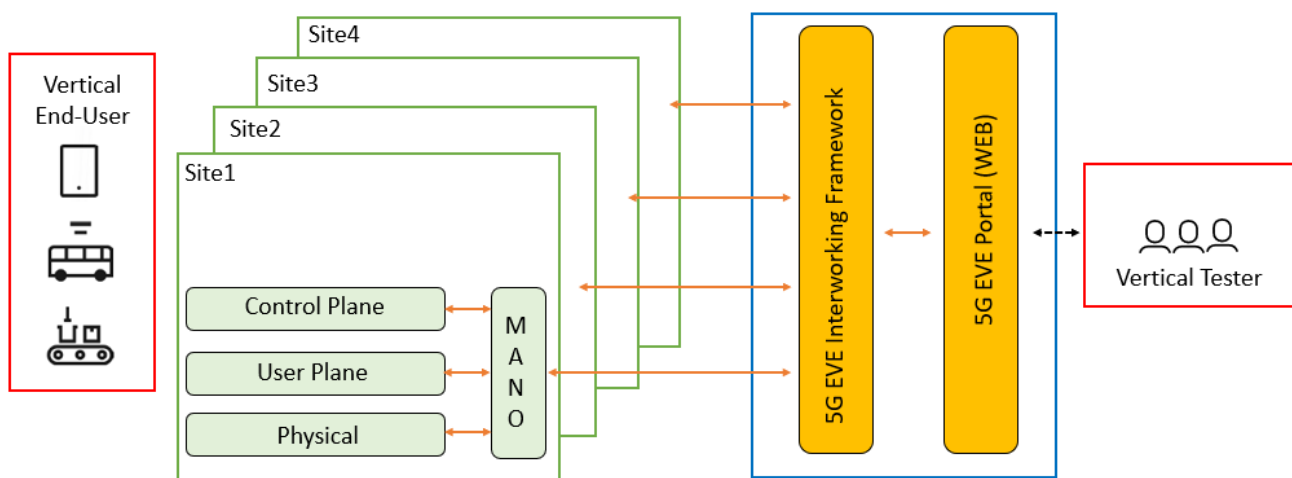

Figure 58: 5G EVE Architecture - Verticals' View

For the verticals/*Experimenter*, the interfaces in the 5G EVE platform are the following:

- 5G NSA supported devices in the first phase of the project.
- ETSI-MEC application boarding for their required application as needed. As the ETSI-MEC supports diversity in the location and implementation of the MEC servers, on each site a different approach could be deployed.
- Web Interfaces (secure web browser) for the *Experimenter* to interact with the 5G EVE Portal.

6.2.2 5G EVE Platform Control Plane Interfaces

The control plane function in 3GPP networks provides the Access Mobility and Management function (AMF) in 5G networks, the Mobility Management Entity (MME) function in 4G networks, and the Serving General Packet Radio Service (GPRS) Support Node (SGSN) function in 2G/3G networks. These systems also support functions as the cellular serving gateway node (C-SGN) for the optimized Internet of Things (IoT) services. The interfaces deliver the scalability, flexibility, high-availability, and performance to meet growing network signalling loads for consumer mobile and Internet of Things (IoT)/Machine Type Communications (MTC) services.

The Control Plane system implemented as a cloud-native architecture will provide the webscale and state-efficient design needed to meet the growing control plane demands and increase in core signalling traffic. The implementation as a cloud-native architecture implementation will be the main preference as it provides a highly scalable, flexible architecture to support an expanded range of services, including mission-critical services and disaster recovery for government, public safety and military, as well as IoT/MTC for energy, transportation, and health care industries.

The main provided functions will include the following components with standardized interfaces:

- **AMF:** As a standalone AMF, the 3GPP packet core authentication and mobility management functions in 5G networks:
 - Termination of radio access network (RAN) control plane interface and Non-Access Stratum (NAS) ciphering and integrity protection.
 - Manages user equipment (UE) registration, access authorization, and authentication, mobility, reachability and connection management.
 - Provides transport for session management (SM) messages between UE and Session Management Function (SMF) and transparent proxy for routing SM messages.
 - Supports Inter-Radio Access Technology (I-RAT) handovers between and within 5G and 4G networks and non-3GPP networks to provide and maintain UE services as users move about the network.
- **MME and SGSN:** these components perform the 3GPP packet core authentication and mobility management functions in 2G/3G/4G networks:
 - Termination of RAN control plane interface, and NAS ciphering and integrity protection.
 - Manages UE/mobile terminal (MT) registration, access authorization and authentication, mobility, reachability and session management.
 - Manages UE bearer setup and management for data and VoLTE services.
 - Manages UE Packet Data Protocol (PDP) context/bearer setup and management for data services.
 - Supports Inter-Radio Access Technology (I-RAT) handovers between and within LTE and 2G/3G networks and non-3GPP networks to provide and maintain UE services as users move about the network.
- **C-SGN:** The system must support also the C-SGN configuration for Cellular IoT (CIoT) networks. This configuration supports 3GPP Release 12 [52], 3GPP Release 13 [53] and 3GPP Release 14 [44] CIoT optimization features that reduce signalling increase scaling and improve device battery life.

In order to leverage the maximum interoperability or the different experimentation sites it is strongly recommended to follow the following 3GPP and IETF standards:

- 3GPP standards: TS 23.003 [54], TS 23.007 [55], TS 23.060 [56], TS 23.216 [57], TS 23.246 [58], TS 23.271 [59], TS 23.272 [60], TS 23.401 [61], TS 23.402 [62], TS 23.501 [25], TS 23.502 [63], TS

24.008 [64], TS 24.171 [65], TS 24.301 [66], TS 25.413 [67], TS 25.415 [68], TS 29.002 [69], TS 29.060 [70], TS 29.118 [71], TS 29.168 [72], TS 29.171 [73], TS 29.172 [74], TS 29.274 [75], TS 29.280 [76], TS 29.303 [77], TS 29.502 [78], TS 29.518 [79], TS 32.426 [80], TS 33.107 [81], TS 33.401 [82], TS 36.412 [83], TS 36.413 [84], TS 36.414 [85], TS 36.444 [86], TS 44.064 [87], TS 44.065 [88], TS 48.016 [89] and TS 48.018 [90].

- IETF standards: RFC 768 (UDP) [91], RFC 791 (IP) [92], RFC 793 (TCP) [93], RFC 1034 (DNS) [94], RFC 1035 (DNS) [95], RFC 4960 (SCTP) [96], RFC 6241 (NETCONF) [97], RFC 6733 (Diameter) [98] and RFC 7540 (HTTP/2) [99].

6.2.3 5G EVE Platform User Plane Interfaces

In order to provide maximum coherence and interoperability in the different sites, the multi-functional packet core mobile gateway should provide increased deployment flexibility, elastic scale, high reliability and the capacity to deliver a full range of mobile and IP services. The cloud networking and state-efficient design will meet the growing bandwidth and device connectivity demands for 4G, 5G and the Internet of Things (IoT). The provided system could be operated in both virtualized and cloud network environments. It can be managed in either a cloud/IT life-cycle management or a traditional Telco network management operations model with a common packet core management system. The system gives communications service providers (CSPs) and enterprises a cloud-native architecture that supports the transition to cloud and software-defined networking (SDN) while providing both 5G non-stand-alone (NSA) and stand-alone (SA) core functions.

It is suggested to implement a disaggregated, decentralized Virtual Network Function (VNF) tiered architecture in the system design:

- Operations, administration, and maintenance (OAM): Performs the control plane functions for the CMG, including management of the individual tiers and routing protocols.
- Supported management interfaces: SNMP/Telnet/SSH/CLI and NETCONF/YANG.
- Common data layer: Stores subscriber state and provides backup of session information.
- Load balancer: Provides external network connectivity (input/output) to mobile gateway functions and load distribution across the CMG VNF. It supports the CMG micro-nets, response time monitoring, RTM, multiple VPRN/VRF, VPLS and contains the mobile gateway tunnel endpoint identifier (TEID) table. The load balancer forwards session and signalling traffic to the assigned control plane processing instance and optionally the user data traffic to the user plane forwarding instance. Optionally the load balancer can be removed from the CMG user plane VNF, providing increased throughput capacity for certain applications.
- User plane forwarding: Performs the packet processing, forwarding and policy enforcement of session data flows of the supported mobile gateway functions. User plane forwarding can be provided with and without the load balancing and either on server-based or physical hardware-based platforms delivering even greater capacity and performance.

The architecture interfaces must support multiple network functions in the 3GPP mobile packet core, both individually as separate VNF instances or in combination as a single VNF instance.

- SGW: The SGW forwards user data packets and acts as the local mobility anchor for the user plane during LTE RAN handovers, as well as handovers with other 3GPP technologies. The system could support both a stand-alone SGW instance or a combined SGW/PGW/GGSN single instance.
- PGW and GGSN: As a stand-alone PGW, GGSN or combined PGW/GGSN, the system interfaces provide connectivity for user equipment (UE) to external packet data networks and is the mobile network IP anchor point. The CMG performs policy enforcement, packet filtering, charging support, lawful interception and packet inspection for each packet flow.
- ePDG and TWAG: The system interfaces function as either a stand-alone ePDG or TWAG function or as a combined Wi-Fi access gateway combining the functions into a single instance supporting both trusted and untrusted Wi-Fi access. As an ePDG in an untrusted non-3GPP access (public) network, it provides a secure entry point through an IPsec tunnel from the mobile device into the CSP packet core. Both open and closed SSID access devices are supported. The system ePDG capabilities could support a variety of wholesale and retail deployment scenarios, enabling both wireline and wireless providers

to leverage unlicensed Wi-Fi as an access technology. As an ePDG, it coordinates with the CSP's back-end subscriber, policy and billing infrastructure for the authentication and parameters needed to create subscriber context.

- **SMF:** The system SMF establishes, modifies and releases 5G sessions for all 5G access types to the 5G Core, provides UE IP address allocation and management, and selection and control of the UPF. It interfaces with the Policy Control Function (PCF), provides the control part of policy enforcement and QoS, as well as lawful intercept. The SMF can be provided as a stand-alone function or in combination with the UPF. PGW-c/SMF and PGW-U/UPF combos are also supported for seamless 4G/5G interworking.
- **UPF:** As the anchor point for intra and inter-RAT mobility as well as the interconnect to the data network, the CMG performs the user plane forwarding and routing for the mobile network as well as packet inspection, policy enforcement and lawful intercept user plane collection. It also performs QoS, uplink/downlink rate enforcement and marking at the transport level as well as uplink classification.
- **NRF:** As the NRF in the 5G Core, the system should support the discovery of services by receiving a discovery request from a Network Function (NF) instance and providing details of the discovered NF instances to the NRF. It maintains the NF profile of the available NF instances in the network and their supported services.
- **NSSF:** As the NSSF in the 5G Core, the CMG selects the appropriate set of Network Slices from the available set of instances serving the UE and determines the appropriate AMF(s) to serve the UE for that set of Network Slices. This can be pre-configured or presented as a list of candidate AMF(s) through NRF query.
- **Mobile Application Assurance:** Nokia Mobile Application Assurance (AA) capabilities provided by the system interfaces deliver a range of high-touch packet processing functions. These may be deployed within the PGW/UPF as integrated Application Detection and Control (ADC), policy and charging enforcement, or in the SSG as a stand-alone 3GPP traffic detection function (TDF) along with other specialized SSG functions. Nokia Mobile AA provides Layer 4 to Layer 7 packet inspection, classification, control and charging capabilities for advanced packet processing and service intelligence in addition to traffic optimization, dynamic congestion control, and Layer 7 stateful firewall. AA provides classification of flows into applications and app-groups, in addition to using machine learning heuristics to classify flow attribute metadata for all flows, including encrypted traffic.
- **SSG:** The system interfaces also support an SSG function, which is located on the CSP SGi-LAN interface and provides service classification and enhanced traffic steering features that optimize the mobile end user experience and generate new service revenue opportunities. In addition to TDF, it also could support Layer 7 charging, TCP-optimization, multi-path TCP hybrid-access gateway, RAN congestion detection and control, carrier-grade Network Address Translation, firewall- and policy-driven traffic steering and service chaining. The SSG could enable the system value-added use cases to be deployed as a stand-alone function for use in conjunction with existing SGW/PGW/UPF functions. This frees up the SGW/PGW/UPF processing resources for bearer management and packet forwarding.

The system interfaces that supports these function message types and procedures are defined in the 3GPP for the 5G Core network functions: TS 23.060 [56], TS 23.203 [54], TS 23.234 [101], TS 23.401 [82], TS 23.402 [62], TS 23.501 [25], TS 23.502 [63], TS 23.503 [102], TS 24.302 [103], TS 29.060 [70], TS 29.212 [104], TS 29.244 [105], TS 29.273 [106], TS 29.274 [75], TS 29.275 [107], TS 29.281 [108], TS 32.251 [109], TS 32.295 [110], TS 32.297 [111], TS 32.298 [112], TS 32.299 [113], TS 33.102 [114], TS 33.106 [115], TS 33.107 [81], TS 33.108 [116] and TS 33.402 [117].

Conclusions

This deliverable has described the 5G end-to-end facility architecture that will support vertical industries that approach to 5G EVE platform, to verify and test their applications and execute experiments in a test environment with 5G-enabled infrastructure but with the flexibility that facilitates to reproduce to some extend live network operation conditions.

The document explains the different functional layers of 5G EVE platform and for each of them, the technologies that will be integrated on each of them are depicted. Additional released documents include detailed technical information of the interfaces and interaction flow among the different components of technologies of the Service Layer or "5G EVE common blocks" (5G EVE portal and I/W Framework) can be found in D4.1 "Experimentation Tools and VNF Repository" [6], D3.1 "Interworking capability definition and gap analysis document" [22], D3.2 "Interworking reference model" [50], D5.1 "Disjoint testing and validation tools" [18] and D5.2 "Model-based testing framework document" [51]. On the other hand, detailed information of integrated and implementation plan per 5G site for "5G EVE site-specific blocks" technologies can be found in D2.1, "Initial detailed architectural and functional site facilities description" [7] and D2.2, "Sites facilities planning" [8].

Along with 5G EVE platform architecture description, and to facilitate a smooth approach of verticals industries to the 5G EVE platform, the document illustrates the typical experiment lifecycle phases (also referred as experiment flow phases in this document), and includes full details for each of them, covering:

- Activities and actors involved.
- Inputs and Outputs.
- Templates examples for files / documents to be used along the experimentation flow process
- 5G EVE platform tools supporting the activity / phase, plus information of when these tools are expected to be available.
- Interaction workflows between 5G EVE users and 5G EVE platform.

Finally, the document also includes information with regards to the expected 5G system performance capabilities of 5G EVE platform along project lifetime.

Acknowledgment

This project has received funding from the EU H2020 research and innovation programme under Grant Agreement No. 815074.

References

- [1] 5G Infrastructure PPP Phase 2 projects (2017-2019). Available: <https://5g-ppp.eu/5g-ppp-phase-2-projects/>
- [2] 5G Infrastructure PPP Phase 3 projects. Available: <https://5g-ppp.eu/5g-ppp-phase-3-projects/>
- [3] 5G EVE D1.1, "Requirements definition and analysis from participant vertical industries", October 2018
- [4] 3GPP Release 15. Available: <https://www.3gpp.org/release-15>
- [5] IMT-2020. Available: <https://www.itu.int/en/ITU-R/study-groups/rsg5/rwp5d/imt-2020/Pages/default.aspx>
- [6] 5G EVE D4.1, "Experimentation Tools and VNF Repository", October 2019
- [7] 5G EVE D2.1, "Initial detailed architectural and functional site facilities description", September 2018
- [8] 5G EVE D2.2, "Sites facilities planning", October 2018
- [9] ETSI GS NFV-SOL 001, "Network Functions Virtualisation (NFV) Release 2; Protocols and Data Models; NFV descriptors based on TOSCA specification", v2.6.1, May 2019
- [10] 5G EVE D1.4 "KPI collection Framework", June 2019
- [11] ETSI GS NFV-SOL 004, "Network Functions Virtualisation (NFV) Release 2; Protocols and Data Models; VNF Package Specification", v2.6.1, April 2019
- [12] <http://5g-transformer.eu/>
- [13] ETSI GS NFV-IFA 014, "Network Functions Virtualisation (NFV) Release 3; Management and Orchestration; Network Service Templates Specification", v3.1.1, August 2018
- [14] ETSI GS NFV-IFA 011, "Network Functions Virtualisation (NFV) Release 3; Management and Orchestration; VNF Descriptor and Packaging Specification", v3.1.1, August 2018
- [15] ETSI GS NFV-SOL 007, "Network Functions Virtualisation (NFV) Release 2; Protocols and Data Models; Network Service Descriptor File Structure Specification", v2.6.1, March 2019
- [16] ETSI GS NFV-SOL 004, "Network Functions Virtualisation (NFV) Release 2; Protocols and Data Models; VNF Package Specification", v2.6.1, April 2019
- [17] ETSI GS NFV-SOL 005, "Network Functions Virtualisation (NFV) Release 2; Protocols and Data Models; RESTful protocols specification for the Os-Ma-nfvo Reference Point", v2.6.1, April 2019
- [18] 5G EVE D5.1, "Disjoint testing and validation tools", April 2019.
- [19] ITU-R M.2083-0, "IMT Vision – Framework and overall objectives of the future development of IMT for 2020 and beyond", September 2015.
- [20] ITU-R M.2410-0, "Minimum requirements related to technical performance for IMT-2020 radio interface(s)", November 2017.
- [21] 3GPP Release 16. Available: <https://www.3gpp.org/release-16>
- [22] 5G EVE D3.1, "Interworking capability definition and gap analysis document", December 2018
- [23] 3GPP TS 28.530, "Management and orchestration; Concepts, use cases and requirements", V15.1.0, December 2018.
- [24] ITU Y.3100, "Terms and definitions for IMT-2020 network", 09/2017
- [25] 3GPP TS 23.501, "System architecture for the 5G System", v15.4.0, December 2018
- [26] 3GPP TS 28.801, "Study on management and orchestration of network slicing for next generation network", v15.1.0, January 2018
- [27] ETSI GR NFV-EVE 012, "Report on Network Slicing Support with ETSI NFV Architecture Framework", v3.1.1, December 2017
- [28] ETSI GS NFV-MAN 001 "(NFV) Management and Orchestration", v1.1.1, December 2014
- [29] <https://www.slideshare.net/EricssonSlides/ericsson-distributed-cloud>
- [30] Mobile-Edge Computing - Introductory Technical White Paper, September 2014
- [31] ETSI White Paper No. 28 "MEC in 5G networks", June 2018
- [32] ETSI White Paper "Network Functions Virtualisation – Introductory White Paper", October 2012
- [33] <https://www.3gpp.org/specifications/releases>
- [34] 3GPP TS 38.401, "NG-RAN; Architecture description", v15.4.0, December 2018
- [35] <https://www.ericsson.com/en/blog/2018/9/5g-nr-release-16--start-of-the-5g-evolution>

- [36] 3GPP TS 38.101-1, "NR; User Equipment (UE) radio transmission and reception; Part 1: Range 1 Standalone", v16.1.0, September 2019
- [37] 3GPP TS 38.101-2, "NR; User Equipment (UE) radio transmission and reception; Part 2: Range 2 Standalone", v16.1.0, September 2019
- [38] 3GPP TS 38.211, "NR; Physical channels and modulation", v15.7.0, September 2019
- [39] 5G PPP Architecture Working Group, "View on 5G Architecture", v3.0, June 2019
- [40] <https://5g-ppp.eu/wp-content/uploads/2017/03/5GPPP-brochure-final-web-MWC.pdf>
- [41] https://bscw.5g-ppp.eu/pub/bscw.cgi/d276025-3/*/*/*DOI-SLICENET-D2.3.html
- [42] https://www.etsi.org/deliver/etsi_ts/123500_123599/123501/15.02.00_60/ts_123501v150200p.pdf
- [43] http://www.3gpp.org/NEWS-EVENTS/3GPP-NEWS/1930-SYS_ARCHITECTURE
- [44] 3GPP Release 14. Available: <https://www.3gpp.org/release-14>
- [45] 3GPP TR 32.842, "Study on network management of virtualized networks", v13.1.0, December 2015
- [46] <https://www.etsi.org/technologies/nfv>
- [47] ETSI GR NFV-IFA 028, "Network Functions Virtualisation (NFV) Release 3; Management and Orchestration; Report on architecture options to support multiple administrative domains", v3.1.1, September 2018
- [48] ETSI GS NFV-IFA 030, "Network Functions Virtualisation (NFV) Release 3; Management and Orchestration; Multiple Administrative Domain Aspect Interfaces Specification", v3.1.1, September 2018
- [49] <https://www.elastic.co/what-is/elk-stack>
- [50] 5G EVE D3.2, "Interworking reference model", June 2019
- [51] 5G EVE D5.2, "Model-based testing framework document", December 2019.
- [52] 3GPP Release 12. Available: <https://www.3gpp.org/release-12>
- [53] 3GPP Release 13. Available: <https://www.3gpp.org/release-13>
- [54] 3GPP TS 23.003, "Numbering, addressing and identification", v15.8.0, 2019-09-18
- [55] 3GPP TS 23.007, "Restoration procedures", 15.4.0, 2019-09-18
- [56] 3GPP TS 23.060, "General Packet Radio Service (GPRS); Service description; Stage 2", 16.0.0, 2019-03-25
- [57] 3GPP TS 23.216, "Single Radio Voice Call Continuity (SRVCC); Stage 2", 16.2.0, 2019-09-24
- [58] 3GPP TS 23.246, "Multimedia Broadcast/Multicast Service (MBMS); Architecture and functional description", 16.1.0, 2019-09-24
- [59] 3GPP TS 23.271, "Functional stage 2 description of Location Services (LCS)", 15.1.0, 2018-09-17
- [60] 3GPP TS 23.272, "Circuit Switched (CS) fallback in Evolved Packet System (EPS); Stage 2", 15.0.0, 2017-12-22
- [61] 3GPP TS 23.401, "General Packet Radio Service (GPRS) enhancements for Evolved Universal Terrestrial Radio Access Network (E-UTRAN) access", 16.4.0, 2019-09-24
- [62] 3GPP TS 23.402, "Architecture enhancements for non-3GPP accesses", 16.0.0, 2019-06-11
- [63] 3GPP TS 23.502, "Procedures for the 5G System (5GS)", 16.2.0, 2019-09-24
- [64] 3GPP TS 24.008, "Mobile radio interface Layer 3 specification; Core network protocols; Stage 3", 16.2.0, 2019-09-24
- [65] 3GPP TS 24.171, "Control Plane Location Services (LCS) procedures in the Evolved Packet System (EPS)", 15.0.0, 2018-06-22
- [66] 3GPP TS 24.301, "Non-Access-Stratum (NAS) protocol for Evolved Packet System (EPS); Stage 3", 16.2.0, 2019-09-24
- [67] 3GPP TS 25.413, "UTRAN Iu interface Radio Access Network Application Part (RANAP) signalling"
- [68] 3GPP TS 25.415, "UTRAN Iu interface user plane protocols", 15.0.0, 2018-07-02
- [69] 3GPP TS 29.002, "Mobile Application Part (MAP) specification", 15.5.0, 2019-06-13
- [70] 3GPP TS 29.060, "General Packet Radio Service (GPRS); GPRS Tunnelling Protocol (GTP) across the Gn and Gp interface", 15.5.0, 2019-06-13
- [71] 3GPP TS 29.118, "Mobility Management Entity (MME) - Visitor Location Register (VLR) SGs interface specification", 15.2.0, 2018-03-28
- [72] 3GPP TS 29.168, "Cell Broadcast Centre interfaces with the Evolved Packet Core; Stage 3", 15.1.0, 2018-09-24

- [73] 3GPP TS 29.171, "Location Services (LCS); LCS Application Protocol (LCS-AP) between the Mobile Management Entity (MME) and Evolved Serving Mobile Location Centre (E-SMLC); SLs interface", 15.3.0, 2019-09-18
- [74] 3GPP TS 29.172, "Location Services (LCS); Evolved Packet Core (EPC) LCS Protocol (ELP) between the Gateway Mobile Location Centre (GMLC) and the Mobile Management Entity (MME); SLg interface", 15.1.0, 2019-09-18
- [75] 3GPP TS 29.274, "3GPP Evolved Packet System (EPS); Evolved General Packet Radio Service (GPRS) Tunnelling Protocol for Control plane (GTPv2-C); Stage 3", 16.1.0, 2019-09-19
- [76] 3GPP TS 29.280, "Evolved Packet System (EPS); 3GPP Sv interface (MME to MSC, and SGSN to MSC) for SRVCC", 15.0.0, 2018-06-23
- [77] 3GPP TS 29.303, "Domain Name System Procedures; Stage 3", 16.0.0, 2019-09-24
- [78] 3GPP TS 29.502, "5G System; Session Management Services; Stage 3", 16.1.1, 2019-10-23
- [79] 3GPP TS 29.518, "5G System; Access and Mobility Management Services; Stage 3", 16.1.1, 2019-10-23
- [80] 3GPP TS 32.426, "Telecommunication management; Performance Management (PM); Performance measurements Evolved Packet Core (EPC) network", 15.3.0, 2019-09-25
- [81] 3GPP TS 33.107, "3G security; Lawful interception architecture and functions", 15.6.0, 2019-06-17
- [82] 3GPP TS 33.401, "3GPP System Architecture Evolution (SAE); Security architecture", 16.0.0, 2019-09-25
- [83] 3GPP TS 36.412, "Evolved Universal Terrestrial Radio Access Network (E-UTRAN); S1 signalling transport", 15.0.0, 2018-06-22
- [84] 3GPP TS 36.413, "Evolved Universal Terrestrial Radio Access Network (E-UTRAN); S1 Application Protocol (S1AP)", 15.7.1, 2019-10-04
- [85] 3GPP TS 36.414, "Evolved Universal Terrestrial Radio Access Network (E-UTRAN); S1 data transport", 15.0.0, 2018-06-22
- [86] 3GPP TS 36.444, "Evolved Universal Terrestrial Radio Access Network (E-UTRAN); M3 Application Protocol (M3AP)", 15.0.0, 2018-09-25
- [87] 3GPP TS 44.064, "Mobile Station - Serving GPRS Support Node (MS-SGSN); Logical Link Control (LLC) Layer Specification", 15.0.0, 2018-06-22
- [88] 3GPP TS 44.065, "Mobile Station (MS) - Serving GPRS Support Node (SGSN); Subnetwork Dependent Convergence Protocol (SNDCP)", 15.0.0, 2018-06-22
- [89] 3GPP TS 48.016, "General Packet Radio Service (GPRS); Base Station System (BSS) - Serving GPRS Support Node (SGSN) interface; Network service", 15.0.0, 2018-06-28
- [90] 3GPP TS 48.018, "General Packet Radio Service (GPRS); Base Station System (BSS) - Serving GPRS Support Node (SGSN); BSS GPRS protocol (BSSGP)", 15.0.0, 2018-06-25
- [91] IETF RFC 768 (UDP), "User Datagram Protocol", 28 August 1980
- [92] IETF RFC 791 (IP), "INTERNET PROTOCOL", September 1981
- [93] IETF RFC 793 (TCP), "TRANSMISSION CONTROL PROTOCOL", September 1981
- [94] IETF RFC 1034 (DNS), "DOMAIN NAMES - CONCEPTS AND FACILITIES", November 1987
- [95] IETF RFC 1035 (DNS), "DOMAIN NAMES - IMPLEMENTATION AND SPECIFICATION", November 1987
- [96] IETF RFC 4960 (SCTP), "Stream Control Transmission Protocol", September 2007
- [97] IETF RFC 6241 (NETCONF), "Network Configuration Protocol (NETCONF)", June 2011
- [98] IETF RFC 6733 (Diameter), "Diameter Base Protocol", October 2012
- [99] IETF RFC 7540 (HTTP/2), "Hypertext Transfer Protocol Version 2 (HTTP/2)", May 2015
- [100] 3GPP TS 23.203, "Policy and charging control architecture", 16.1.0, 2019-06-11
- [101] 3GPP TS 23.234, "3GPP system to Wireless Local Area Network (WLAN) interworking; System description", 13.1.0, 2017-03-13
- [102] 3GPP TS 23.503, "Policy and charging control framework for the 5G System (5GS); Stage 2", 16.2.0, 2019-09-24
- [103] 3GPP TS 24.302, "Access to the 3GPP Evolved Packet Core (EPC) via non-3GPP access networks; Stage 3", 16.2.0, 2019-09-24
- [104] 3GPP TS 29.212, "Policy and Charging Control (PCC); Reference points", 16.1.0, 2019-09-27
- [105] 3GPP TS 29.244, "Interface between the Control Plane and the User Plane nodes", 16.1.0, 2019-09-18
- [106] 3GPP TS 29.273, "Evolved Packet System (EPS); 3GPP EPS AAA interfaces", 15.4.0, 2019-09-24

- [107] 3GPP TS 29.275, "3GPP Evolved Packet System (EPS); Evolved General Packet Radio Service (GPRS) Tunnelling Protocol for Control plane (GTPv2-C); Stage 3", 16.1.0, 2019-09-19
- [108] 3GPP TS 29.281, "General Packet Radio System (GPRS) Tunnelling Protocol User Plane (GTPv1-U)", 15.6.0, 2019-09-24
- [109] 3GPP TS 32.251, "Telecommunication management;Charging management;Packet Switched (PS) domain charging", 15.5.0, 2019-06-12
- [110] 3GPP TS 32.295, "Telecommunication management; Charging management; Charging Data Record (CDR) transfer", 15.0.0, 2018-06-21
- [111] 3GPP TS 32.297, "Telecommunication management; Charging management; Charging Data Record (CDR) file format and transfer", 16.0.0, 2019-09-25
- [112] 3GPP TS 32.298, "Telecommunication management; Charging management; Charging Data Record (CDR) parameter description", 16.2.0, 2019-09-25
- [113] 3GPP TS 32.299, "Telecommunication management; Charging management; Diameter charging applications", 16.1.0, 2019-06-12
- [114] 3GPP TS 33.102, "3G security; Security architecture", 15.1.0, 2018-12-18
- [115] 3GPP TS 33.106, "3G security; Lawful interception requirements", 15.1.0, 2018-06-21
- [116] 3GPP TS 33.108, "3G security; Handover interface for Lawful Interception (LI)", 15.6.0, 2019-09-28
- [117] 3GPP TS 33.402, "3GPP System Architecture Evolution (SAE); Security aspects of non-3GPP accesses", 15.1.0, 2018-06-21

Annex A.1 Experiment template for verticals

TO BE FILLED BY THE VERTICAL: please, include a brief description of the experiment to be executed, including what are your expected capabilities from the 5G-EVE infrastructure (3-5 lines).

Experiment Description:
Expected Capabilities:

TO BE FILLED BY THE VERTICAL: please, include a brief description of your own components that you will be deploying on top of 5G-EVE infrastructure as part of this experiment. Please, include also the deployment requirements for these components. For virtual elements, these requirements may include RAM, disk, vCPUs, etc.; for physical ones, information about size, power requirements, etc. will be required. Main objective with this section is to help determining the required capabilities on the hosting sites.

Table 1: Experiment components

Component Name	Description	Deployment requirements

TO BE FILLED BY THE VERTICAL: please, include a brief description or figure on how the previous components interact with each other. This way we can derive the connectivity requirements for your experiment.

Experiment architecture:

TO BE FILLED BY THE VERTICAL: please, include a list of all the KPIs (network related or internal to your application) that are of interest for you during experimentation. For each of these, please determine if they can be empirically measured directly during experimentation (either by your own components or by external ones), and, for those which are not network related, if there is a known relationship with network parameters like latency, jitter, throughput, etc. For experiments with KPIs that cannot be empirically measured, or with not known relationships with network parameters, it may still be possible to execute them on 5G-EVE, but the Vertical should only expect validations based on its own local human analysis.

Table 2: Meaningful KPIs

KPI	Is it measurable during experimentation?	Is there a known relationship with network parameters?

TO BE FILLED BY THE VERTICAL. INSTRUCTIONS:

- There should be (ideally one and only) one test case for each high-level KPI which is meaningful for the Vertical running the experiment.
- The required information implies the minimum required for 5G-EVE partners to derive the low-level test plan, meaningful from an infrastructure point of view. Fields include:
 - Target KPI: should include which KPI wants to be measured (one per test case)
 - Measurement method: should include the procedure the vertical uses to measure the target KPI in its own tests. E.g. component A is measuring KPI A, putting results in a database in component B, from where they can be accessed
 - Parameters: should include which variables (external conditions) the vertical uses to ensure the experiment conditions match those of the production environment. E.g. number of users, background traffic, etc.
 - Validation conditions: should include the conditions the target KPI should meet to consider the test as passed. E.g. KPI A should be below a certain threshold during the whole experiment. If the objective of the test is actually to measure the KPI under different conditions, this field may just include “To measure the KPI”. That type of tests will not generate a pass/not passed result in the test report, but will just provide the measurements.

Test Case 1	
Test Name:	
Target KPI:	
Measurement Method:	
Parameters:	
Validation Conditions:	

Figure 59: Experiment template for verticals

Annex A.2 Example of Low Level Test Plan Template

TO BE FILLED BY THE 5G-EVE CONSORTIUM. INSTRUCTIONS:

- There should be (ideally one and only) one test case for each high-level KPI which is meaningful for the Vertical running the experiment.
- If derived from the external conditions, the “expected results” change, then this can be reflected in different Test Sub-cases. Ideally, the Test Objective, Prerequisites, and Required Capabilities will be common, while the rest of the fields will be completed on a per sub-case basis.
- The fields on each Test Case are:
 - Test Objective, to be derived mainly from “Target KPI” in Vertical Test Plan
 - Test Prerequisites, to be derived mainly from “Experiment Description” and/or “Measurement Method” in Vertical Test Plan. This reflects if any initial conditions are to be met before launching the test
 - Required Capabilities, to be derived mainly from “Experiment Description” and/or “Measurement Method” in Vertical Test Plan. This reflects the requirements imposed to the potential hosting sites, to make sure they can support the experiment.]
- The fields associated with each Test Sub-case are:
 - Test Topology, to be derived mainly from “Experiment Description”
 - Test Variables, to be derived mainly from “Parameters” in Vertical Test Plan
 - Test Procedure, to be derived mainly from “Experiment Description” and “Measurement Method” in Vertical Test Plan
 - Expected Results, to be derived mainly from “Expected Results” in Vertical Test Plan

Test Case 1	
Test Name:	
Test Objective:	
Test Prerequisites:	
Required Capabilities:	
Sub-Case 1	Test Topology:
	Test Variables:
	Test Procedure:
	Expected results:
Sub-Case 2	Test Topology:
	Test Variables:
	Test Procedure:
	Expected results:

Figure 60: Example of Low Level Test Plan Template

Annex A.3 Example of VSB

```
{
  "version": "0.1",
  "name": "AstiAGVControl",
  "description": "Asti AGV control service ",
  "parameters": [
    {
      "parameterId": "sensor_amount",
      "parameterName": "sensor_amount",
      "parameterType": "number",
      "parameterDescription": "number of guiding sensors",
      "applicabilityField": "efactory"
    },
    {
      "parameterId": "sensor_amount",
      "parameterName": "sensor_amount",
      "parameterType": "number",
      "parameterDescription": "number of guiding sensors",
      "applicabilityField": "efactory"
    }
  ],
  "atomicComponents": [
    {
      "componentId": "masterPLC",
      "serversNumber": 3,
      "endPointsIds": [
        "mplc_data_ext"
      ]
    },
    {
      "componentId": "EPC",
      "serversNumber": 1,
      "endPointsIds": [
        "pEPC_data"
      ]
    }
  ],
  "endPoints": [
    {
      "endPointId": "agv_sap_data",
      "external": true,
      "management": true,
      "ranConnection": true
    },
    {
      "endPointId": "mplc_data_ext",
      "external": true,
      "management": true,
      "ranConnection": false
    },
    {
      "endPointId": "pEPC_data",
      "external": true,
      "management": true,
      "ranConnection": false
    }
  ],
  "connectivityServices": [
    {
```

```
    "endPointIds": [
      "agv_sap_data",
      "mplc_data_ext",
      "pEPC_data"
    ],
    "external": true
  }
],
"serviceSequence": [
  {
    "hopEndPoints" [
      {
        "vsComponentId": "masterPLC",
        "endPointId": "mplc_data_ext"
      }
    ]
  },
  {
    "hopEndPoints" [
      {
        "vsComponentId": "EPC",
        "endPointId": "pEPC_data",
      }
    ]
  }
],
"compatibleContextBlueprints": [
  "traffic_generation",
  "network_delay_emulation"
],
"compatibleSites": [
  "ITALY_TURIN"
]
}
```

Annex A.4 Example of CB

```

{
  "version": "0.1",
  "name": "traffic_generation",
  "description": "Generator of network traffic",
  "parameters": [
    {
      "parameterId": "tg_001",
      "parameterName": "bandwidth",
      "parameterType": "number",
      "parameterDescription": "target bandwidth in bits/sec",
      "applicabilityField": "all"
    },
    {
      "parameterId": "tg_002",
      "parameterName": "streams",
      "parameterType": "number",
      "parameterDescription": "number of parallel connections",
      "applicabilityField": "all"
    }
  ],
  "atomicComponents": [
    {
      "componentId": "client",
      "serversNumber": 1,
      "endPointsIds": [
        "source",
        "client_mgt"
      ]
    },
    {
      "componentId": "server",
      "serversNumber": 1,
      "endPointsIds": [
        "sink",
        "server_mgt"
      ]
    }
  ],
  "endPoints": [
    {
      "endPointId": "source",
      "external": false,
      "management": false,
      "ranConnection": false
    },
    {
      "endPointId": "client_mgt",
      "external": true,
      "management": true,
      "ranConnection": false
    },
    {
      "endPointId": "sink",
      "external": false,
      "management": false,
      "ranConnection": false
    }
  ]
}

```

```
    "endPointId": "server_mgt",
    "external": true,
    "management": true,
    "ranConnection": false
  },
  {
    "endPointId": "mgt_sap",
    "external": true,
    "management": true,
    "ranConnection": false
  }
],
"connectivityServices": [
  {
    "endPointIds": [
      "mgt_sap",
      "client_mgt",
      "server_mgt"
    ],
    "external": true
  },
  {
    "endPointIds": [
      "source",
      "sink"
    ],
    "external": false
  }
],
"serviceSequence": [
  {
    "hopEndPoints" [
      {
        "vsComponentId": "client",
        "endPointId": "source"
      }
    ]
  },
  {
    "hopEndPoints" [
      {
        "vsComponentId": "server",
        "endPointId": "sink",
      }
    ]
  }
],
"compatibleSites": [
  "ITALY_TURIN",
  "GREECE_ATHENS",
  "SPAIN_5TONIC"
]
}
```

Annex A.5 Example of ExpB

```

{
  "expBlueprint": {
    "name": "ASTI control loop stress experiment",
    "sites": [
      "ITALY_TURIN"
    ],
    "tcBlueprintIds": [
      "{{tcb_id}}"
    ],
    "version": 0.1,
    "vsBlueprintId": {{vsb_id}},
    "ctxBlueprintIds": [
      "{{cb_id}}"
    ],
    "description": "ASTI Control loop stress experiment",
    "kpis": [
      {
        "formula": "kpi_formula",
        "interval": "kpi_interval",
        "kpiId": "kpi_id",
        "metricIds": [
          "test_metric_id",
          "ctx_app_metric_id"
        ],
        "name": "string",
        "unit": "string"
      }
    ],
    "metrics": [
      {
        "iMetricType": "LOST_PKT",
        "interval": "string",
        "metricCollectionType": "CUMULATIVE",
        "metricId": "exp_metric_id",
        "name": "exp_metric_name",
        "unit": "exp_metric_unit"
      }
    ]
  },
  "translationRules": [
    {
      "nsdId": "string",
      "nsdVersion": "string",
      "nsFlavourId": "string",
      "nsInstantiationLevelId": "string",
      "input": [
        {
          "parameterId": "string",
          "minValue": 0,
          "maxValue": 0
        }
      ],
      "blueprintId": "string"
    }
  ],
  "nsds": [
    {
      "nsdIdentifier": "astiExpNsd",

```



```

"designer": "NXW",
"version": "0.1",
"nsdName": "ASTI Experiment NSD",
"nsdInvariantId": "Traffic Generator Service",
"vnfdId": [

],
"nestedNsdId": [
    "trafficGenerator",
    "nsAstiAgvControl"
],
"sapd": [

],
"virtualLinkDesc": [

],
"nsDf": [
    {
        "nsDfId": "nsExp_df",
        "flavourKey": "nsExp_fk",
        "vnfProfile": [

],
        "virtualLinkProfile": [

],
        "nsInstantiationLevel": [
            {
                "nsLevelId": "nsExp_il",
                "description": "Default instantiation level for the Exp NS",
                "vnfToLevelMapping": [

],
                "virtualLinkToLevelMapping": [

],
                "nsToLevelMapping": [
                    {
                        "nsProfileId": "nsAstiAgvControl_profile",
                        "numberOfInstances": 1
                    }, {
                        "nsProfileId": "trafficGenerator_profile",
                        "numberOfInstances": 1
                    }
                ]
            }
        ],
        "defaultNsInstantiationLevelId": "nsExp_il",
        "dependencies": []
    }
],
"security": {
    "signature": "NSD_SIGNATURE",
    "algorithm": "NSD_ALGORITHM",
    "certificate": "NSD_CERTIFICATE"
}
}
]
}

```

Annex A.6 Example of TCB

```
{
  "testCaseBlueprint": {
    "description": "string",
    "infrastructureParameters": {
      "additionalProp1": "string",
      "additionalProp2": "string",
      "additionalProp3": "string"
    },
    "name": "string",
    "script": "string",
    "userParameters": {
      "additionalProp1": "string",
      "additionalProp2": "string",
      "additionalProp3": "string"
    },
    "version": "string"
  }
}
```

Annex A.7 Example of ExpD

```

{
  "contextDetails": [
    {
      "blueprintId": "{{cb_id}}",
      "parameters": {
        "flow_amount": "10"
      }
    }
  ],
  "experimentBlueprintId": "{{expb_id}}",
  "kpiThresholds": {
    "additionalProp1": "string",
    "additionalProp2": "string",
    "additionalProp3": "string"
  },
  "name": "ASTI STRESS TEST",
  "tenantId": "{{tenant}}",
  "testCaseConfiguration": [
    {
      "blueprintId": "{{tcb_id}}",
      "parameters": {
        "additionalProp1": "string",
        "additionalProp2": "string",
        "additionalProp3": "string"
      }
    }
  ],
  "version": "0.1",
  "vsDescriptor": {
    "managementType": "PROVIDER_MANAGED",
    "name": "string",
    "qosParameters": {
      "vehicle_amount": 10
    }
  },
  "serviceConstraints": [
    {
      "atomicComponentId": "string",
      "canIncludeSharedElements": true,
      "nonPreferredProviders": [
        "string"
      ],
      "preferredProviders": [
        "string"
      ],
      "priority": "LOW",
      "prohibitedProviders": [
        "string"
      ],
      "sharable": true
    }
  ],
  "sla": {
    "availabilityCoverage": "AVAILABILITY_COVERAGE_HIGH",
    "lowCostRequired": true,
    "serviceCreationTime": "SERVICE_CREATION_TIME_LOW"
  },
  "sst": "NONE",

```

```
"version": "string",  
  "vsBlueprintId": "{{vsb_id}}"  
}
```

Annex A.8 Example of NSD

```

{
  "nsd": {
    "nsdIdentifier": "nsAstiAgvControl",
    "designer": "NXW",
    "version": "0.1",
    "nsdName": "Autonomous Guided Vehicle Control service @ 5GEVE",
    "nsdInvariantId": "Autonomous Guided Vehicle Control service @ 5GEVE",
    "vnfdId": [
      "masterPLC"
    ],
    "pnfdId": [
      "EPC"
    ],
    "sapd": [{
      "cpdId": "agv_sap_data",
      "description": "SAP for all the AGV service",
      "layerProtocol": "IPV4",
      "cpRole": "ROOT",
      "addressData": [{
        "addressType": "IP_ADDRESS",
        "ipAddressAssignment": false,
        "floatingIpActivated": true,
        "ipAddressType": "IPv4",
        "numberOfIpAddress": 1
      }],
      "sapAddressAssignment": false,
      "nsVirtualLinkDescId": "agv_vl_data"
    }],
    "virtualLinkDesc": [{
      "virtualLinkDescId": "agv_vl_data",
      "virtualLinkDescProvider": "NXW",
      "virtualLinkDescVersion": "0.1",
      "connectivityType": {
        "layerProtocol": "IPV4"
      }
    }],
    "virtualLinkDf": [{
      "flavourId": "fc_vl_df_data",
      "qos": {
        "latency": 0,
        "packetDelayVariation": 0,
        "packetLossRatio": 0,
        "priority": 0
      },
      "serviceAvailabilityLevel": "LEVEL_1",
      "bitrateRequirements": {
        "root": 2,
        "leaf": 2
      }
    }],
    "description": "Network to connect to the AGV devices"
  }],
  "nsDf": [{
    "nsDfId": "nsAgv_df",
    "flavourKey": "nsAgv_fk",
    "vnfProfile": [{
      "vnfProfileId": "vAgv_profile",
      "vnfdId": "masterPLC",
      "flavourId": "masterPLC_df",

```



```
    }, {
      "nsLevelId": "nsAgv_il_big",
      "description": "Big instantiation level for AGV service",
      "vnfToLevelMapping": [{
        "vnfProfileId": "masterPLC_profile",
        "numberOfInstances": 3
      }],
      "virtualLinkToLevelMapping": [{
        "virtualLinkProfileId": "agv_vl_profile_data",
        "bitRateRequirements": {
          "root": "1",
          "leaf": "1"
        }
      }
    ]
  },
  ],
  "defaultNsInstantiationLevelId": "nsAgv_il_small"
}],
"security": {
  "signature": "FC_NSD_SIGNATURE",
  "algorithm": "FC_NSD_ALGORITHM",
  "certificate": "FC_NSD_CERTIFICATE"
}
}
```