



Paylaşım Kültürü ve Açık Lisanslar

Orçun Madran

Creative Commons Türkiye, Şube Lideri

Kimin için AÇIK?

 OPEN ACCESS WEEK 2019

OCTOBER
21-27

¿ABIERTO PARA QUIÉN?

EQUIDAD EN EL CONOCIMIENTO ABIERTO
मुक्त प्रवेश किसके लिए खुला? खुले ज्ञान में समानता

OPEN FOR WHOM?

EQUITY IN OPEN KNOWLEDGE

حر لمن؟ الإنصاف في المعرفة المفتوحة

OUVERT POUR QUI?

ÉQUITÉ DANS LE SAVOIR OUVERT

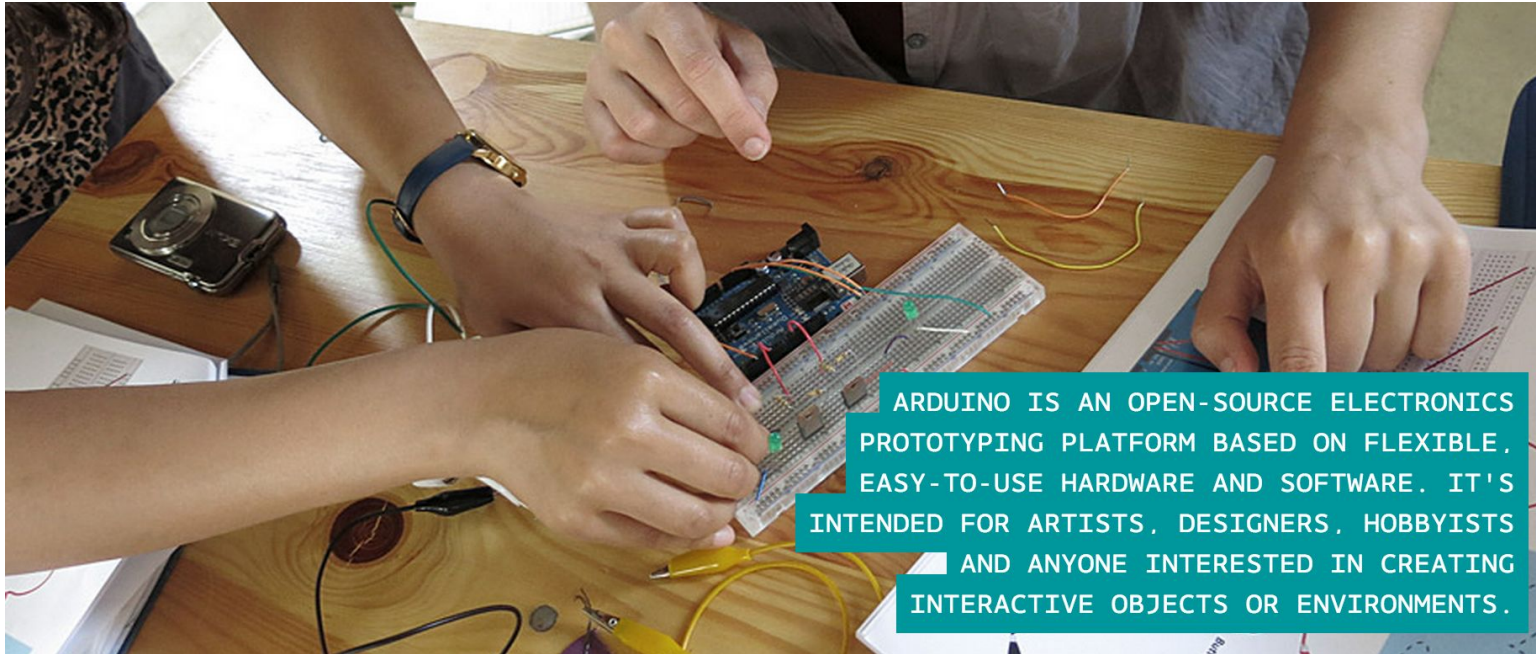

ARDUINO IS AN OPEN-SOURCE ELECTRONICS
PROTOTYPING PLATFORM BASED ON FLEXIBLE,
EASY-TO-USE HARDWARE AND SOFTWARE. IT'S
INTENDED FOR ARTISTS, DESIGNERS, HOBBYISTS
AND ANYONE INTERESTED IN CREATING
INTERACTIVE OBJECTS OR ENVIRONMENTS.

Örnek Proje: Arduino - arduino.cc

Arduino(TM) UNO Rev3

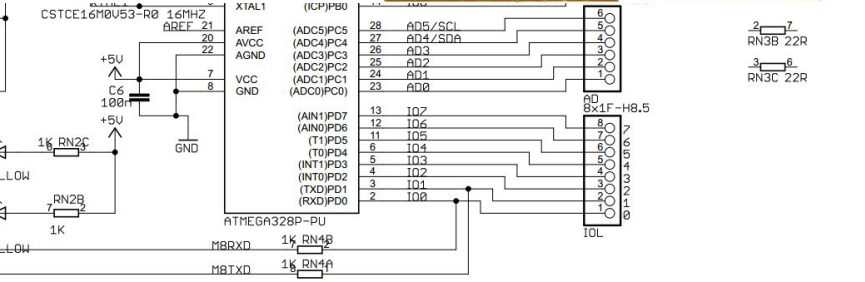
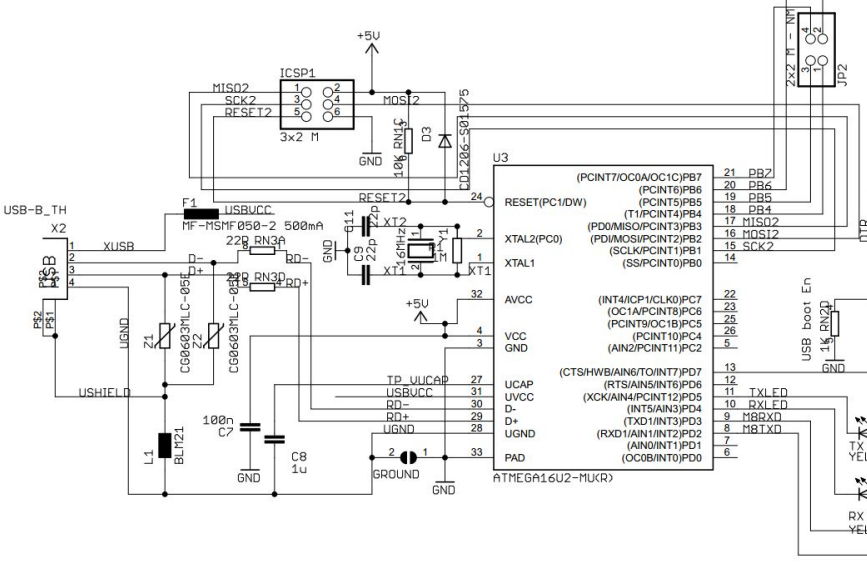
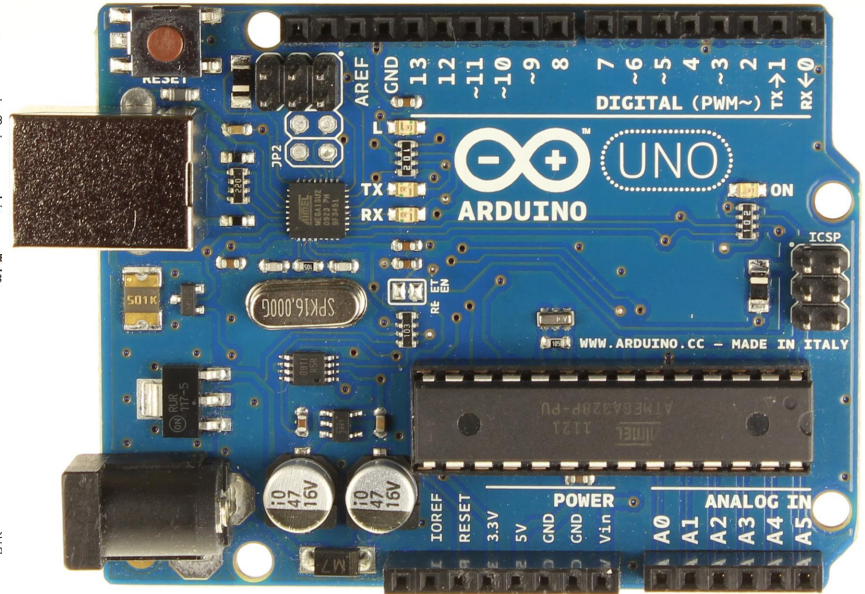
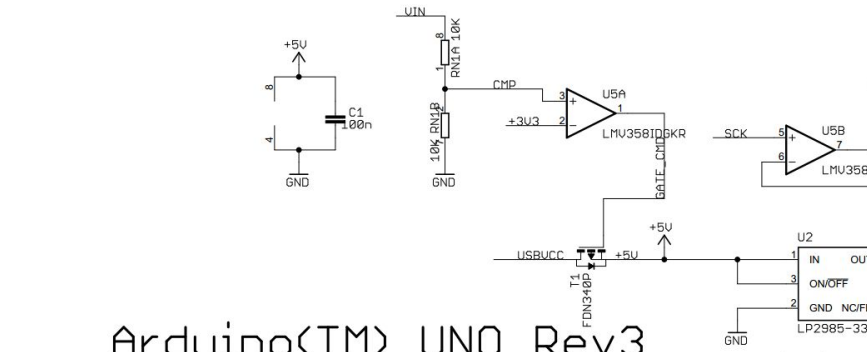

Açık Donanım

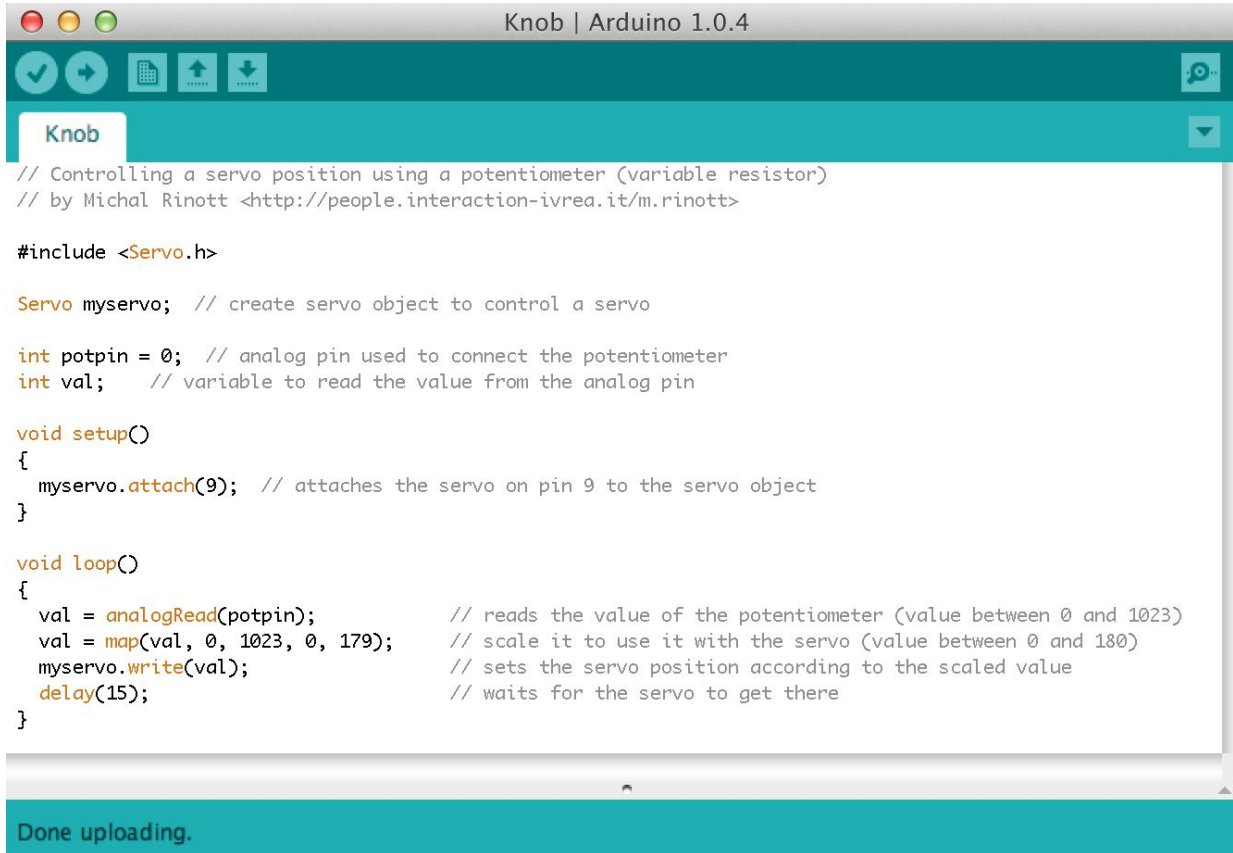

```
// Controlling a servo position using a potentiometer (variable resistor)
// by Michal Rinott <http://people.interaction-ivrea.it/m.rinott>

#include <Servo.h>

Servo myservo; // create servo object to control a servo

int potpin = 0; // analog pin used to connect the potentiometer
int val; // variable to read the value from the analog pin

void setup()
{
  myservo.attach(9); // attaches the servo on pin 9 to the servo object
}

void loop()
{
  val = analogRead(potpin); // reads the value of the potentiometer (value between 0 and 1023)
  val = map(val, 0, 1023, 0, 179); // scale it to use it with the servo (value between 0 and 180)
  myservo.write(val); // sets the servo position according to the scaled value
  delay(15); // waits for the servo to get there
}
```

Done uploading.

Açık Kaynak Kod

 [Advanced Search](#)

In: Journals Articles

Search results: Found 14

Listing 1 - 10 of 14

<< page 1 of 2 >>

Sort by



Article

Remote Educational Experiment Applied To Electrical Engineering

Authors: João Mota Neto --- Roderval Marcelino --- Carlos Eduardo Pereira --- Vilson Gruber --- et al.

Journal: International Journal of Online Engineering (iJOE) **ISSN/EISSN:** 18612121 **Year:** 2013

Volume: 9 **Issue:** 1 **Pages:** 47-51 **DOI:** 10.3991/ijoe.v9i1.2298

Publisher: Kassel University Press

[Abstract](#) | [Keywords](#) | [Fulltext](#) | [Export](#) | [TOC](#) |  [SHARE](#)



Article

Performance Evaluation of MMA7260QT and ADXL345 on Self Balancing Robot

Authors: Hany Ferdinando --- Handry Khoswanto --- Djoko Purwanto

Journal: TELKOMNIKA **ISSN/EISSN:** 16936930 **Year:** 2013 **Volume:** 11 **Issue:** 1 **Pages:** 1-10

Publisher: Ahmad Dahlan University

[Abstract](#) | [Keywords](#) | [Fulltext](#) | [Export](#) | [TOC](#) |  [SHARE](#)

Narrow your search

Resource type

- article (14) 

Language

- english (14) 

License

- CC by (11)
- CC by-nc-nd (3)

Publication fee

- With charges (14) 

Year

From To 

Açık Erişim

[Buy](#) ▾[Download](#)[Products](#)[Learning](#) ▾[Reference](#)[Support](#) ▾[Blog](#)[LOG IN](#)[SIGN UP](#)

Getting Started with Arduino

Introduction: What Arduino is and why you'd want to use it.

Installation: Step-by-step instructions for setting up the Arduino software and connecting it to an Arduino Uno, Mega2560, Duemilanove, Mega, or Diecimila.

- [Windows](#)
- [Mac OS X](#)
- [Linux](#) (on the playground wiki)

Environment: Description of the Arduino development environment and how to change the default language.

Libraries: Using and installing Arduino libraries.

Troubleshooting: Advice on what to do if things don't work.

Instructions for other boards:

- [Arduino BT](#)
- [Arduino Due](#)
- [Arduino Fio](#)
- [Arduino Leonardo and Micro](#)
- [Arduino Esplora](#)
- [LilyPad Arduino USB](#)
- [LilyPad Arduino](#)
- [Arduino Mini](#)
- [Arduino Nano](#)
- [Arduino Pro](#)
- [Arduino Pro Mini](#)
- [Arduino Robot](#)
- [Arduino Yún](#)
- [Ethernet shield](#)
- [GSM shield](#)
- [TFT LCD Screen](#)
- [Wireless shield](#)
- [WiFi shield](#)

The text of the Arduino getting started guide is licensed under a [Creative Commons Attribution-ShareAlike 3.0 License](#).

Code samples in the guide are released into the public domain.

Açık Ders Malzemesi - Arduino Playground



BROWSE BY:

CHANNELS

TYPE

SPOTLIGHT

SURPRISE ME



Arduino Tutorial #1

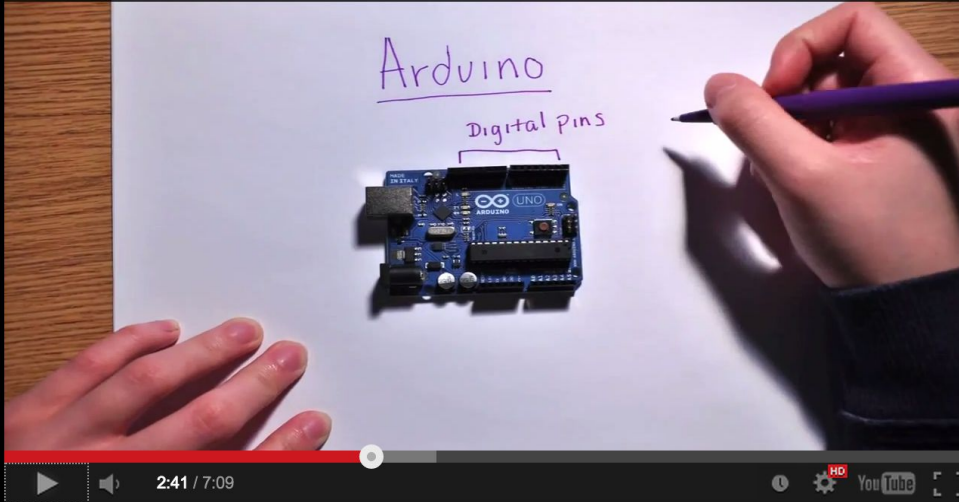

POPOUT



FLAG



SHARE

<http://mit.tv/laW3jw>

EMBED

CHANNEL

[MIT+K12, Engineering](#)

TYPE

[Educational, Demonstration](#)

SOURCE

[MIT+K12](#)

TAGS

Arduino Tutorial #1

Learn about electronics using an Arduino.

Açık Ders Malzemesi - MIT Video



CC Lisanslarını Keşfedelim

CC lisansları üç katmanlı bir yapıya sahiptirler.

1. Hukuksal Metin (Legal Code)
2. İnsan Tarafından Okunabilen (Human Readable)
3. Makina Tarafından Okunabilen (Machine Readable)



Hukuksal Metin (Legal Code)

- Her lisans için geleneksel bir hukuk aracıdır.
- Farklı dillerde (İngilizce, Almanca, Türkçe, Çince, ...) ve metin formatındadır
- Çoğu hukuk insanı bu yapıyı bilir ve sever..!



Attribution 4.0 International

Official translations of this license are available [in other languages](#).



Creative Commons Corporation ("Creative Commons") is not a law firm and does not provide legal services or legal advice. Distribution of Creative Commons public licenses does not create a lawyer-client or other relationship. Creative Commons makes its licenses and related information available on an "as-is" basis. Creative Commons gives no warranties regarding its licenses, any material licensed under their terms and conditions, or any related information. Creative Commons disclaims all liability for damages resulting from their use to the fullest extent possible.

Using Creative Commons Public Licenses

Creative Commons public licenses provide a standard set of terms and conditions that creators and other rights holders may use to share original works of authorship and other material subject to copyright and certain other rights specified in the public license below. The following considerations are for informational purposes only, are not exhaustive, and do not form part of our licenses.

Considerations for licensors: Our public licenses are intended for use by those authorized to give the public permission to use material in ways otherwise restricted by copyright and certain other rights. Our licenses are irrevocable. Licensors should read and understand the terms and conditions of the license they choose before applying it. Licensors should also secure all rights necessary before applying our licenses so that the public can reuse the material as expected. Licensors should clearly mark any material not subject to the license. This includes other CC-licensed material, or material used under an exception or limitation to copyright. [More considerations for licensors](#).

İnsan Tarafından Okunabilen (Human Readable)

- Lisansların sıradan insanlar tarafından okunabilen halidir
- Ortak Tapu (Commons Deed) olarak da bilinirler
- Ortak Tapular, Hukulsa Metinlerin kullanıcı dostu halleridir.



Attribution 4.0 International (CC BY 4.0)

This is a human-readable summary of (and not a substitute for) the [license](#).

[Disclaimer](#)



You are free to:

- Share** — copy and redistribute the material in any medium or format
- Adapt** — remix, transform, and build upon the material for any purpose, even commercially.

The licensor cannot revoke these freedoms as long as you follow the license terms.

Under the following terms:

- Attribution** — You must give [appropriate credit](#), provide a link to the license, and [indicate if changes were made](#). You may do so in any reasonable manner, but not in any way that suggests the licensor endorses you or your use.

No additional restrictions — You may not apply legal terms or [technological measures](#) that legally restrict others from doing anything the license permits.

Makina Tarafından Okunabilen (Machine Readable)

- Bilgi sistemleri, arama motorları ve harmanlama teknolojilerini kullanan yazılımlar tarafından paylaşım koşullarının anlaşılabilmesini sağlar
- CC Hakları İfade Dili'ni kullanır (Rights Expression Language) (CC REL)

```
1. the study by VOLKAN TEMEL is licensed under a
2.
3. <a rel="license" href="http://creativecommons.org/licenses/by-nc/3.0/">Creative Commons
4. Attribution Non-Commercial 3.0 License</a>.
5. Permissions beyond the scope of this license may be available at
6. <a xmlns:cc="http://creativecommons.org/ns#" rel="cc:morePermissions"
7. href="http://www.hindawi.com/journal/arp/
8.
9. === Advanced ===
10. <pre>
11. <span xmlns:cc="http://creativecommons.org/ns#" xmlns:dc="http://purl.org/dc/terms/">
12.
13. <span rel="dc:type" href="http://purl.org/dc/dcmitype/Text" property="dc:title">My Book</span> by
14. <a rel="cc:attributionURL" property="cc:attributionName" href="http://rejon.org/my_book">Jon Phillips</a>
15.
16. is licensed under a
17.
18. <a rel="license" href="http://creativecommons.org/licenses/by-nc/3.0/">Creative Commons
19. Attribution Non-Commercial 3.0 License</a>.
20.
21. <span rel="dc:source" href="http://deerfang.org/her_book/">
22. Permissions beyond the scope of this license may be available at
23. <a rel="cc:morePermissions"
24. href="http://somecompany.com/revenue_sharing_agreement">somecompany.com</a>.
25.
26. </span>
```

CC İkonlarını Tanıyalım

Dört Ana Lisans İkonu



Atıf - Attribution (BY)



AynıLisanslaPaylaş - ShareAlike (SA)



GayriTicari - NonCommercial (NC)



Türetilemez - NoDerivatives (ND)

Telifsiz Eserlerde Creative Commons



Hiçbir hakkı saklı değildir - No Rights Reserved (CC0)

Eser sahibinin telif hakkı ve bağı haklarından feragat ettiği durumdur. Bilim insanları, eğitimciler, sanatçılar ve diğer yaratıcıların ihtiyaçlarına yanıt olarak doğmuştur.



Kamu malı - No Known Copyright - Public Domain Mark (PDM)

Telif süresi bitmiş, kamunun malı olmuş eserler için kullanılır. Telif süresi ülkeden ülkeye değişmekle birlikte, 50 yıl (ör: Türkiye'de 70 yıl) ve daha uzun süreler ile korunmaktadır.



Atıf
CC BY



Atıf - AynıLisanslaPaylaş
CC BY-SA



Atıf - Türetilemez
CC BY-ND



Atıf - Gayriticari
CC BY-NC



Atıf - Gayriticari - AynıLisanslaPaylaş
CC BY-NC-SA



Atıf - Gayriticari - Türetilemez
CC BY-NC-ND

**Eserlerimizi CC ile
nasıl lisanslarız?**

Share your work on a Creative Commons platform

We work with platforms like Wikipedia, Flickr, and Vimeo to provide their users with the option of licensing works with CC licenses. Through these platforms, over 1.4 billion works have been shared and counting!

The Flickr logo, featuring the word "flickr" in a lowercase, sans-serif font. The "f" is blue, and the "lickr" is pink.The Bandcamp logo, consisting of a blue parallelogram icon followed by the word "bandcamp" in a lowercase, sans-serif font.The Wikipedia logo, featuring the word "WIKIPEDIA" in a bold, uppercase, serif font.The YouTube logo, featuring the word "You" in black and "Tube" in white inside a red rounded rectangle.The 500 logo, featuring the number "500" in a blue, stylized font.The Internet Archive logo, featuring the words "INTERNET ARCHIVE" in a vertical stack on the left and a stylized classical building icon on the right.The Vimeo logo, featuring the word "vimeo" in a lowercase, blue, sans-serif font.The Wikimedia Commons logo, featuring a blue circular icon with a red dot and a white arrow, and the words "WIKIMEDIA COMMONS" below it.The FMA logo, featuring the letters "FMA" in a bold, black, sans-serif font.The Skills Commons logo, featuring the words "SKILLS COMMONS" in a bold, black, sans-serif font, with "open for learning" in a smaller font below it.The Europeana logo, featuring a stylized "e" icon and the words "europeana think culture" in a lowercase, sans-serif font.The Tribe of Noise logo, featuring a square icon with a stylized figure and the words "Tribe of Noise" in a lowercase, sans-serif font.The Jamendo logo, featuring the word "jamendo" in a lowercase, purple, sans-serif font.The MIT OpenCourseWare logo, featuring the words "MIT OPEN COURSEWARE" in a bold, black, sans-serif font, with "MASSACHUSETTS INSTITUTE OF TECHNOLOGY" in a smaller font below it.The PLOS logo, featuring a stylized globe icon and the word "PLOS" in a bold, black, sans-serif font.



Share your work

Use & remix

What we do

Blog

Help us build a vibrant, collaborative global commons



Donate Now

Share, Collaborate, Remix, Reuse

We're changing the way people share around the world with our Global Community and 1.4 billion pieces of content under our simple, easy-to-use open licenses.

State of the Commons



<https://creativecommons.org/>

Choose a license

This chooser helps you determine which Creative Commons License is right for you in a few easy steps. If you are new to Creative Commons, you may also want to read [Licensing Considerations](#) before you get started.



**Choose
Features**



**Optional
Info**



**Get
License**

Get Started

<https://creativecommons.org/share-your-work/>

New to Creative Commons? [Consider]
Explore the Creative Commons
[Looking for earlier]

Licens

Your choices on this panel w

Allow adaptatio

Yes No

Allow comn

This page is available in the following languages:

Castellano Castellano (España) Català Dansk Deutsch English Esperanto français Galego
hrvatski Indonesia Italiano Latviski Lietuvių Magyar Melayu Nederlands Norsk polski Português
Português (BR) Português (Portugal) română Slovenščina Suomeksi svenska **Türkçe** Íslenska
česky Ελληνικά Беларуская русский українська العربية پارسی 中文 日本語 華語 (台灣)
한국어

Selected License

Attribution 4.0 International



This is a Free Culture License!



<https://creativecommons.org/choose/?lang=tr>

<https://creativecommons.org/choose/>

Lisans Özellikleri

Bu paneldeki tercihiniz diğer panellerdeki bilgileri günceller.

Eserinizin adaptasyonlarının paylaşılmasına izin veriyor musunuz?



- Evet Hayır Aynı lisansla dağıtıldığı sürece, evet

Ticari amaçla kullanılmasına izin verilsin mi?



- Evet Hayır

<https://creativecommons.org/choose/?lang=tr>



Seçilmiř Lisans

Alıntı 4.0 Uluslararası



Bu bir Free Culture Lisansıdır!





<https://creativecommons.org/choose/?lang=tr>

Lisans Özellikleri

Bu paneldeki tercihiniz diğer panellerdeki bilgileri günceller.

Eserinizin adaptasyonlarının paylaşılmasına izin veriyor musunuz?

- Evet Hayır Aynı lisansla dağıtıldığı sürece, evet
-  

Ticari amaçla kullanılmasına izin verilsin mi?

- Evet Hayır
-  

<https://creativecommons.org/choose/?lang=tr>



Seçilmiş Lisans

Alıntı-Gayriticari-Türetilemez 4.0 Uluslararası



Bu bir Free Culture Lisansı değildir.



<https://creativecommons.org/choose/?lang=tr>

Diğerlerinin size atıf yapmasına yardımcı olun!

Bu kısım tercihe bağılıdır, fakat doldurulması HTML kodu içine makina tarafından okunabilen metada ekleyecektir!







<https://creativecommons.org/choose/?lang=tr>

Diğerlerinin size atıf yapmasına yardımcı olun!

Bu kısım tercihe bağılıdır, fakat doldurulması HTML kodu içine makina tarafından okunabilen metada ekleyecektir!

<https://creativecommons.org/choose/?lang=tr>

Bu kısım tercihe bağlıdır, fakat doldurulması HTML kodu içine makina tarafından okunabilen metada ekleyecektir!

Eserinizin başlığı	<input type="text"/>	
Eseri bir ad ile alıntı vermek	<input type="text"/>	
Eseri bir URL ile alıntı vermek	<input type="text"/>	
Kaynak eser URL	<input type="text"/>	
Daha fazla izin URL	<input type="text"/>	
Eserin formatı	<input type="text" value="Diğer / Çoğul formatlar"/>	
Lisans işareti	<input type="text" value="HTML+RDFa"/>	

<https://creativecommons.org/choose/?lang=tr#metadata>

Web sayfanız mı var?



Bu eser [Creative Commons Alıntı-Gayriticari-Türetilemez 4.0 Uluslararası Lisansı](https://creativecommons.org/licenses/by-nc-nd/4.0/) ile lisanslanmıştır.

Ziyaretçilerinizin bilmesi için bu kodu kopyalayın!

```
<a rel="license"
href="http://creativecommons.org/licenses/by-nc-nd/4.0/"><img alt="Creative Commons Lisansı"
style="border-width:0"
src="https://i.creativecommons.org/l/by-nc-
```

<https://creativecommons.org/choose/?lang=tr#metadata>

?

Seçilmiş Lisans

Alıntı-LisansDevam 4.0 Uluslararası



Bu bir Free Culture Lisansıdır!



?

Seçilmiş Lisans

Alıntı-Gayriticari-Türetilemez 4.0 Uluslararası



Bu bir Free Culture Lisansı değildir.



Free Culture (Özgür Kültür) kavramı

Understanding Free Cultural Works

Creative Commons provides a range of licenses, each of which grants different rights to use the materials licensed under them. All of these licenses offer more permissions than “all rights reserved.”

To help show more clearly what the different CC licenses let people do, CC marks the most permissive of its licenses as “Approved for Free Cultural Works.” When you apply these licenses to material you create, it meets [the Freedom Defined definition](#) of a “Free Cultural Work.” Free cultural works are the ones that can be most readily used, shared, and remixed by others, and go furthest toward creating a commons of freely reusable materials.

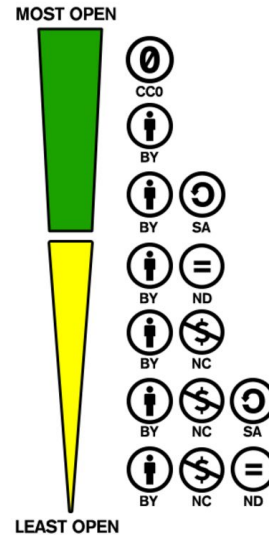

In this section

- ▶ [Licensing considerations](#)
- ▶ [Licensing types](#)
- ▶ [Public domain](#)
 - ▶ [CC0](#)
 - ▶ [Public Domain Mark](#)
 - ▶ [Understanding Free Cultural Works](#)
- ▶ [Places to share](#)
- ▶ [For developers](#)



CONNECT WITH CREATIVE COMMONS

Your email

Sign up to Our Newsletter

<https://creativecommons.org/share-your-work/public-domain/freeworks/>

CC Lisanslı Eserleri Nasıl Buluruz?

flickr

bandcamp

WIKIPEDIA

YouTube

500

INTERNET ARCHIVE

vimeo

WIKIMEDIA
COMMONS

FMA

SKILLS COMMONS
open for learning

 europeana
think culture

 Tribe of Noise

jamendo

MIT OPEN COURSEWARE
MASSACHUSETTS INSTITUTE OF TECHNOLOGY

 PLOS



Everyone's photos

[View all 643](#)



<https://www.flickr.com/search/?l=commderv&q=kitab>



Home

Lists

About

Search the commons...



Feedback

"Sunrise In The Alps" by Markus Trienke is licensed under CC BY-SA 2.0

<https://ccsearch.creativecommons.org/>

Cycling

Search

Filter

3207 Cycling Photos

Grid Options: Contain image



Feedback

<https://ccsearch.creativecommons.org/search?q=Cycling>



[« Back to search results](#)



PHOTO INFO

Title
Cycling in Oxford

Creator
[Tejvan Pettinger](#)

License
CC BY 2.0



Source
[Flickr](#)

Dimensions
2560 X 1920 pixels

PHOTO ATTRIBUTION

"Cycling in Oxford" by [Tejvan Pettinger](#) is licensed under CC BY 2.0

[Copy to HTML](#)

[Copy to Text](#)

Feedback

#AEHaftası: Paylaşım Kültürü ve Açık Lisanslar Semineri

Ekim 23, 2018 by Creative Commons Türkiye

Açık Erişim Haftası kapsamında Creative Commons Türkiye olarak etkinliklerimize devam ediyoruz. 24 Ekim 2018, Çarşamba günü 12:30 – 13:30 arası Bilkent Üniversitesi Özgür Yazılım ve İnternet Teknolojileri Topluluğu'nun davetlisi olarak Bilkent Üniversitesi Kütüphanesi'nde "Paylaşım Kültürü ve Açık Lisanslar" konulu bir seminer gerçekleştireceğiz. Creative Commons Türkiye Şube Lideri Orçun Madran tarafından verilecek olacak seminerde Paylaşım Kültürü kavramı ... [Read more](#)

📁 CCTR Etkinlik Serisi

🔗 Açık Erişim Haftası, Açık Lisanslar, Bilkent Üniversitesi, Orçun Madran, Paylaşım Kültürü

💬 Leave a comment

CC Lisansını Seç

🐦 Takip et @CCturkiye

✓ Beğen Paylaş Sen ve 279 diğer kişi bunu beğendiniz.



<http://creativecommons.org.tr/>

Entellektüel Birikimler ve Bilimsel Arařtırmalar Nasıl “Açık Kültür” Haline Dönüřür?

Açık Bilim nasıl hayat bulur?

- Açık Kaynak Kod
- Açık Eriřim
- Açık Veri
- Açık Eđitim
- Açık Donanım
- Açık Lisans



8

7. Ulusal Açık Bilim Konferansı
ve OpenAIRE Advance Çalıştayı
19-20 Kasım 2019
E.Ü Atatürk Kültür Merkezi, Konak, İzmir

Grup Çalışmaları

Açık Lisanslar - Odak Konular

Çalıştay Odak Konusu - 1

- Araştırma verilerinin paylaşımında açık lisansların rolü.
- “Açık Lisanslar” ile ilgili farkındalık sağlanmış olup olmamasının araştırma verilerinin paylaşımı için önemli
- Teknik ve hukuki açıdan araştırma verilerinin paylaşımında açık lisansların kullanımı

Çalıştay Odak Konusu - 2

- Araştırma verileri dışında kamu hizmetleri sonucu ortaya çıkan verinin (anonimleştirilerek) açık veri olarak paylaşımına sunulmasının inovasyona katkısı
- Kamu hizmetleri sonucu oluşan büyük verinin açık veri olarak kullanılabilmesi
- Kamu verisinin kullanımı için proje önerileri (ör: belediyeler)

Çalıştay Odak Konusu - 3

- GKAM (Galeriler, Kütüphaneler, Arşivler, Müzeler) / GLAM
- GKAM'larda yer alan koleksiyonun dijitalleştirilmesi sonrası yaşanan telif tekeli (Kamu malı - CC0)
- Telif hakkının sona ermesi ile kamu malına dönüşen içeriğin özgürleştirilmesi

Çalıştay Odak Konusu - 4

- Açık Lisanslar (ve tüm açık bilim) ile ilgili çevrim içi eğitim içeriğinin geliştirilmesi: OpenMOOC
- OpenMOOC'un yerelleştirilmesi
- OpenMOOC için içeriğinin Türkiye için özelleştirilmesi
- Yükseköğretim'de müfredatın bir parçası olması

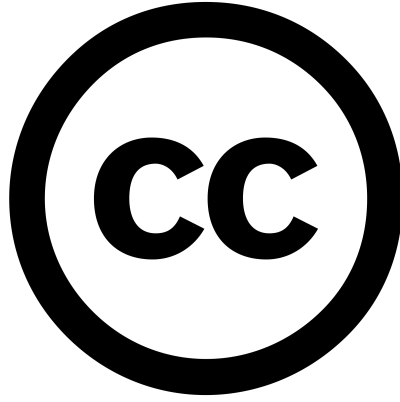

Teşekkürler :))