

## Status of new safety measures considered for European Sodium Fast Reactor in the ESFR-SMART project

J. Guidez<sup>1\*</sup>, J. Bodi<sup>2</sup>, K. Mikityuk<sup>2</sup>, A. Rineiski<sup>3</sup>, E. Girardi<sup>4</sup>

<sup>1</sup>CEA, CEN Saclay 91190 Gif sur Yvette France

<sup>2</sup>Paul Scherrer Institut, Forschungsstrasse 111, 5232 Villigen PSI, Switzerland

<sup>3</sup>Karlsruhe Institute of Technology, IKET, B.421, 76344 Eggenstein-Leopoldshafen, Germany

<sup>4</sup>EDF Lab Paris-Saclay, Safety and Fuel Cycle group, 7, bd Gaspard Monge, 91120, Palaiseau, France

\*Corresponding Author, E-mail: Joel.GUIDEZ@cea.fr

Following up the previous European projects EFR and CP ESFR, a new EU project, called ESFR-SMART, was launched in September 2017. This project applies the new safety rules taking into account the Fukushima accident in order to increase the safety level of the European Sodium Fast Reactor (ESFR) and reach the highest safety standards by simplifying the design and by using all the positive features of the Sodium Fast Reactors (SFR). The first ideas about the new safety measures proposed to increase the intrinsic safety level of the reactor have been presented at ICAPP 2018. This paper gives more detailed description of the new safety measures proposed for ESFR. The main measures are followings:

- *Core design with improved safety parameters:* special geometry and composition was designed to significantly decrease the global void reactivity effect and reduce the probabilities of severe accidents. Three types of control rods are considered, including active, *i.e.* human-activated, and passive, *i.e.* activated by physical parameters, *e.g.* by sodium temperature or flowrate.
- *Improved primary sodium confinement:* The new design of the reactor pit is proposed to be able to confine the primary sodium leaking from the reactor vessel. The level of sodium in the reactor vessel in this case is designed to remain high enough to assure natural convection through the core. A massive metallic roof above the reactor pit is assumed to assure the sodium containment even in the case of the worst severe accidents. A number of other measures are selected to avoid primary sodium leaks out of the reactor pit and the roof.
- *Secondary loops design efficient in natural convection:* Even in case of loss of feedwater in steam generators and loss of electricity supply for secondary pumps, the measures are taken on the secondary loops to assure an efficient decay heat removal by active or passive ways. These measures will include an optimized geometry of the secondary loops to promote the natural convection of the secondary sodium, the use of fully passive thermal pumps to increase the cooling flow rate, and the use of the steam generators modules to promote the cooling of their external surfaces by the natural convection of atmospheric air.
- *Special devices for the decay heat removal systems.*

The main drawings of the modified ESFR, including the above-described measures, have been made and the main results are presented in the paper. Using these drawings, several calculations have begun to evaluate these measures and to demonstrate the final compliance of the proposed design to safety requirements. In the next phases of the ESFR-SMART project, the project will also recommend additional R&D needed for implementations of these safety measures in the future.

**KEYWORDS:** *safety measures, sodium fast reactor, ESFR-SMART*

### Introduction: safety and simplicity

The ESFR-SMART project is a four-year EU project that began in September 2017. It follows the EU CP ESFR project which was also a follow-up to the European project EFR (European Fast Reactor). One of the purposes of this project is to propose and assess the new safety measures, based on the previous projects taking into account the new safety rules induced after the Fukushima accident. Rather than adding devices to improve safety, we propose to simplify the reactor design (we believe that “simpler is safer”) and to promote passivity or intrinsic safety of the protection systems. In this paper we present how we simplified the design (suppression of the reactor dome, suppression of the safety vessel, suppression of the decay heat removal (DHR) systems with independent sodium circuits in the primary vessel, *etc.*) and how we increased the passivity of the safety systems (passively-actuated control rods, passive decay heat removal, *etc.*) and the intrinsic safety. A deliverable proposing a list of the new safety measures and a new preliminary design of the European Sodium Fast Reactor (ESFR) was issued in July 2018 [14]. The paper presents in a compact way the content of this deliverable.

Mis en forme : Police :(Par défaut)  
Arial, Non Gras

## General safety objectives for Generation-IV SFR

For Generation-IV SFRs, a probabilistic objective of the core-meltdown accident prevention is proposed to be the same as for Generation-III Pressurized Water Reactors (*i.e.* a core damage frequency below  $10^{-5}$  per reactor-year for all events including external hazards, with considerations of uncertainties [8]). An additional and prescriptive reduction of the core-meltdown probability is not justified and might be even counterproductive. Indeed, the current probabilistic objectives are already ambitious and at the edge of representativeness. On the other hand, the effort for Generation-IV SFRs should focus on the safety demonstration. In particular, for Generation-IV SFRs, for which limited experience feedback is available, the safety demonstration will rely primarily on deterministic methods so as to cover the defence-in-depth levels and to implement measures for prevention and mitigation of core-meltdown accidents. Probabilistic methods, whenever relevant, will provide an additional insight.

The Fukushima accident lessons have led to the following guidelines so as to make the plant more robust against natural hazards:

- to ensure that sufficient design margins are available on the equipment necessary to avoid cliff effects in terms of off-site radiological consequences, for natural hazards more severe than those considered in the plant design basis domain;
- to favour a plant significant autonomy, for example by promoting passivity or grace period in operation;
- to promote implementation of internal or external measures of intervention on the site in a damaged state.

For Generation-IV reactors the methodology of practical elimination is to be applied from the beginning of the design studies, to identify possibilities of all severe accident situations and to make them extremely rare with a high level of confidence through appropriate design and operating provisions [22].

Mis en forme : Police :(Par défaut)  
Arial, Non Gras

Despite this high level of core-meltdown prevention, mitigation provisions for this accident are adopted under the fourth level of defence in depth. In the event of a core-meltdown accident, the objective is to have very low radiological releases, and according to current thresholds, such that no off-site measures have to be implemented. If measures are nevertheless needed (*e.g.* restrictions on the consumption of crops), these must be limited in time and space, with sufficient time for their implementation. The even-temporary evacuation of populations should not be necessary and only their sheltering, limited in time and space, would be required.

## Safety measures to improve the control of the reactivity

Several measures are proposed with the goal to improve the core reactivity control in ESFR-SMART, with related targets of redundancy, independence and diversity.

### ***New core concept with reduced sodium void effect***

In order to prevent core power excursion, a core design is proposed with a number of innovations, including increase of the fuel pin diameter, introduction of a sodium plenum above the fuel bundles, axial heterogeneity (fertile and fissile parts) of the core, *etc.* [33]. This new core concept is characterized by a close-to-zero global sodium void effect and may provide a more favourable natural behaviour in most of the accidental transient sequences, such as Unprotected Loss of Flow (“unprotected” means a failure of scram).

Mis en forme : Police :(Par défaut)  
Arial, Non Gras

### ***Passive control rod***

Passive control rods are proposed as self-actuated reactivity control devices for the core. The absorber insertion into the reactor thus occurs passively, *i.e.* when some criteria on physical parameters are met, *e.g.* low primary sodium flow rate or high primary sodium temperature [33] and without any use of Instrumentation and Control (I&C).

Mis en forme : Police :(Par défaut)  
Arial, Non Gras

### ***Ultra-sonic measurements for knowledge of the core geometry***

It is suggested to study the potential of ultrasonic measures at the core periphery to monitor its global geometry during operations and to verify the absence of significant gaps between subassemblies (thus further preventing the risk of significant core compaction).

## Safety measures to improve the confinement of radioactive materials

### **Recovery of the safety vessel functions by the reactor pit**

The CP-ESFR safety vessel function was to contain the sodium in the event of the main vessel leakage, while maintaining a level of sodium sufficient to allow the sodium inlet into the intermediate heat exchanger (IHX) and keeping a sodium circulation for the core cooling. We propose to suppress this safety vessel and to recover this function by the reactor pit. For that, we propose to design the reactor pit with a metal-sheet liner so as to withstand a possible sodium leak and to bring the reactor pit closer to the reactor vessel so that the volume between the vessel and pit is lower than the sodium volume leading to uncovering of the IHX inlet.

This option allows the following anticipated advantages:

- The replacement of the safety vessel by a liner with a DHR system attached, increase decay heat removal capabilities through the reactor pit.
- The safety demonstration with respect to a potential question related to the double leak of the two vessels is provided.
- The reactor pit design is well adapted to the severe accident mitigation functions.
- The reactor vessel in-service inspection remains possible (by using the space between the vessel and liner).

The design of the reactor pit without safety vessel as well as preliminary estimates of the heat removal efficiency through the reactor pit is presented in a separate ICAPP 2019 paper [44].

Mis en forme : Police :(Par défaut)  
Arial, Non Gras

### **Massive metallic roof**

The Superphenix SFR experience [55] leads to the recommendation that the bottom of the reactor roof should be kept hot (so as to minimize the aerosol deposits) and should have no water cooling. This last recommendation will be a key point for demonstrating the practical elimination of a significant water ingress into the primary system. The massive metallic roof was therefore selected in the EFR project. This choice has many other advantages such as neutron shielding and mechanical resistance. The reactor roof thickness is to be defined by the industrial manufacturing possibilities, but should have a thickness of about 80 cm. In the upper part, a heat insulator will eventually be installed so as to limit the heat flux to be evacuated during nominal operation by air flow in forced or even natural convection.

Mis en forme : Police :(Par défaut)  
Arial, Non Gras

### **Suppression of dome or polar table**

Primary sodium leakage through the roof in case of an energetic core meltdown scenario is very difficult to predict and therefore can lead to very conservative estimations, including conservative calculations of overpressures in the containment. That makes it necessary to implement as an additional barriers such systems as dome or polar table which are expensive, quite complex and complicating the reactor operation.

Minimization of the reactor roof penetrations is proposed with the goal to practically eliminate any primary sodium leaks and to suppress dome or polar table in the design. In particular:

- Such large components as pumps and heat exchangers are already firmly bolted to prevent earthquake issues. For these components a sealing shell is proposed to be welded so as to provide leak tightness in fast overpressure transients. These components are not intended to be frequently handled, but if this handling is required, a welding joint cutting will enable their easy removal and replacement.
- For rotating plugs independently of the possible inflatable seals, the leak tightness with eutectic seals, which are liquefied during the handling phases so as to enable the rotation [55, 66], is recommended. Conversely, in normal operation these seals are solidified and the design should eventually be such that there is no leakage possibility in the case of a severe accident with energy release. The design and safety investigations will be necessary to reach this goal.
- Consistently with this strategy, to improve the primary sodium confinement in the reactor vessel, it is also proposed to consider:
  - a primary sodium cold trap installed inside the reactor vessel, likewise at Superphenix, so as to avoid any primary sodium circulation outside the vessel;
  - a sufficiently low argon pressure in the cover gas to avoid any sodium-fountain effect of a plunging pipe.

Mis en forme : Police :(Par défaut)  
Arial, Non Gras

Mis en forme : Police :(Par défaut)  
Arial, Non Gras

## Safety measures to improve decay heat removal systems

Three DHR systems (Figure 1Figure-4) are proposed and briefly introduced below.. They take in account also objectives of redundancy and independence.

Mis en forme : Police :(Par défaut)  
Arial

### Decay heat removal by the secondary loops

The secondary circuits are the normal power removal circuits (Figure 2Figure-2). Their application for DHR is very useful since that allows creating in the IHX a cold column of the primary sodium essential for the establishment of a good natural convection in the primary circuit in case of loss of primary pumps. The secondary circuit design will be optimized so as to enable a good heat removal by air in natural convection, that is to say, in the extreme situation when both the feedwater and the electrical power supply have been lost. For this purpose, several measures are proposed:

Mis en forme : Police :(Par défaut)  
Arial

- A loop design enabling an easy establishment of natural convection will be studied.
- The design for steam generators (SGs) used in the CP ESFR project, with six modules per loop will be kept. We will take advantage of the large external surface, related to the SG modular design, to have opportunities for cooling these modules by atmospheric air in natural or forced convection through openings of windows in the SG casings (see Figure 1Figure-4), likewise at Phenix reactor, as shown in [66]. This will be the heat sink for the secondary loop in case of feedwater loss.
- One or more thermal pumps (see Figure 2Figure-2) are proposed to be added to the secondary circuits. Thermal pumps (see Figure 5Figure-5b) are passive electromagnetic pumps using thermoelectricity generated by the difference in temperatures and with no need for external electricity supply. The thermal pumps operate also in nominal conditions.

Mis en forme : Police :(Par défaut)  
Arial

Mis en forme : Police :(Par défaut)  
Arial, Non Gras

Mis en forme : Police :(Par défaut)  
Arial

Mis en forme : Police :(Par défaut)  
Arial

### Decay heat removal by the reactor pit

In addition to the secondary DHR loops, there are two independent cooling circuits in the reactor pit, one with oil system brazed on the liner and one with water inside the concrete capable to maintain the pit concrete at temperatures below 70°C in all situations including severe accident consequences mitigation. These systems are presented in [44]. After about three days these systems can provide full decay heat removal.

Mis en forme : Police :(Par défaut)  
Arial, Non Gras

### Passive decay heat removal systems connected to the IHX

To demonstrate the practical elimination (probability below  $10^{-7}$ ) of the DHR function loss, it is proposed to add cooling circuits (DHRS-1) with sodium/air heat exchangers connected to the IHXs (Figure 3Figure-3). These six circuits use secondary sodium and have several advantages compared to independent systems located in the primary circuit (formerly used in the CP-ESFR project):

Mis en forme : Police :(Par défaut)  
Arial

- No additional penetrations in the reactor roof are required (gain on the reactor vessel diameter and the reactor roof leak tightness).
- The cold column is maintained in the IHX, which is the guarantee of an efficient natural convection of the primary sodium through the core.
- DHRS-1 uses secondary sodium and therefore already existing purification circuit of the corresponding secondary loop and minimizes the number of sodium circuits to be managed by the operator.
- It is still available even when the secondary loop is drained, because the IHX remains full of sodium.
- The circuit operates in natural convection, but the addition of a thermal pump can further increase its capabilities and helps for starting of the operation without a risk of freezing.
- Reduction of the risk of primary sodium leak out of the primary vessel due to minimization of the reactor roof penetrations.
- More resilient in case of energy release in the core during a severe accident, because located out of the reactor vessel and protected by the IHX structures.

To summarize: they are three DHR systems as shown in Figure 1Figure 4:

Mis en forme : Police :(Par défaut)  
Arial

- Six passive systems (called DHRS-1) able to remove power even if the secondary loop is drained, in natural convection (by atmospheric air).
- Six secondary loops able to remove decay heat in active (by feedwater) and/or passive ways (by atmospheric air, called DHRS-2).
- Two active circuits in oil and water in the pit (called DHRS-3) described and calculated in [44].

Mis en forme : Police :(Par défaut)  
Arial, Non Gras, Vérifier l'orthographe et la grammaire

A common failure of these systems seems very unlikely, because redundancy of systems, and because, ~~even if~~ we drain all secondary loops (DHRS2), the DHRS 1 remain ~~available~~ available.

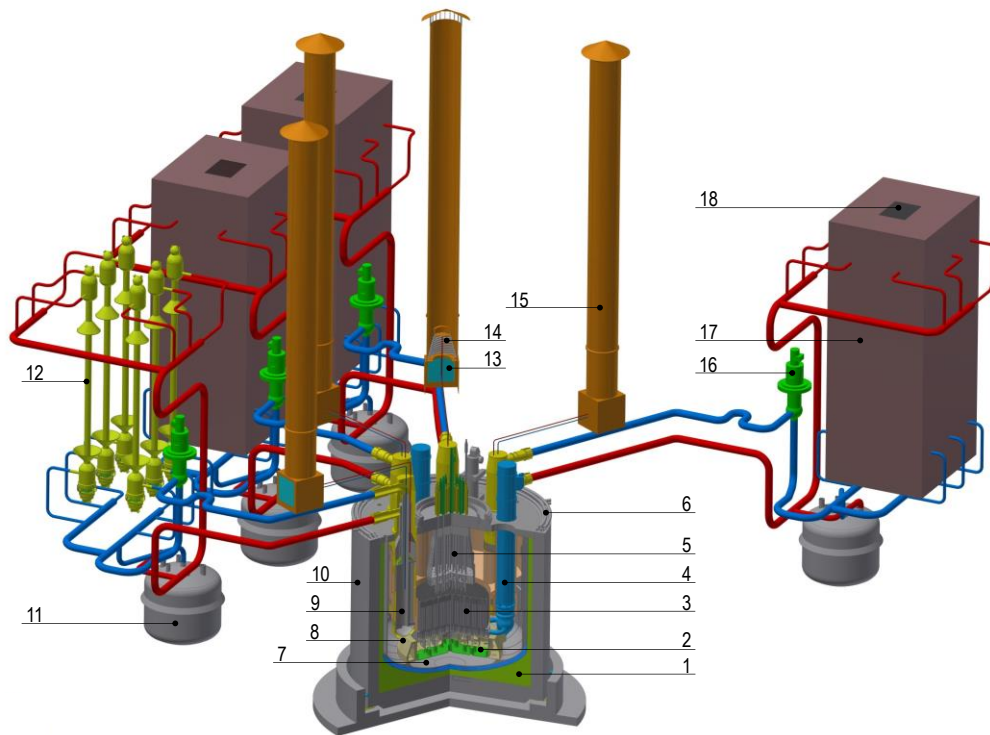

- |                                   |   |
|-----------------------------------|---|
| 1: Insulation with metallic liner | 10: Reactor pit                         |
| 2: Core catcher                   | 11: Secondary sodium tank               |
| 3: Core                           | 12: Steam generator                     |
| 4: Primary pump                   | 13: Window for air circulation (DHRS-1) |
| 5: Above-core structure           | 14: Sodium-air HX (DHRS-1)              |
| 6: Pit cooling system (DHRS-3)    | 15: Air chimney (DHRS-1)                |
| 7: Main vessel                    | 16: Secondary pump                      |
| 8: Strongback                     | 17: Casing of SGs (DHRS-2)              |
| 9: IHX                            | 18: Window for air circulation (DHRS-2) |

Figure 1: General view of ESRF design as proposed in the ESRF-SMART project

### Severe accident mitigation

The proposed safety measures (in particular, the core design providing the low sodium void reactivity effect) are expected to result in reduction of severe accident probability and decrease of energy released in severe accidents compared to the previous ESRF design (CP ESRF project). Moreover, a more robust design is proposed for severe accident mitigation using the following measures:

- The same Pu content used in inner and outer fuel zones exclude the possibility of a positive reactivity insertion during mixing of inner and outer zones with different Pu contents in a molten fuel pool in case of a hypothetical severe accident.
- Mitigation devices inside the core (corium discharge tubes) are intended to channel the molten fuel to the core catcher (Figure 4 and Figure 5a) reducing the probability of a large molten fuel/steel pool formation compared to the previous designs.
- An in-vessel core catcher is provided at the bottom of the vessel, aiming at receiving the whole core meltdown (Figure 4). The re-criticality of the corium in the core catcher should be

Mis en forme : Police :(Par défaut)  
 Arial, 10 pt

Mis en forme : Police :(Par défaut)  
 Arial, 10 pt

Mis en forme : Police :(Par défaut)  
 Arial, 10 pt

prevented by using dedicated absorbing material such as hafnium. The long-term removal of the decay heat generated by the corium should be provided by common operation of all DHR systems (DHRs-1, -2 and -3) taking into account possible failures according to the safety requirements.

- The reactor pit is designed to withstand the sodium leakage and with its upper thick metal roof should form a robust containment system.

The final objective is to demonstrate that here is no significant radioactivity release and no needs of population evacuation in case of severe accident.

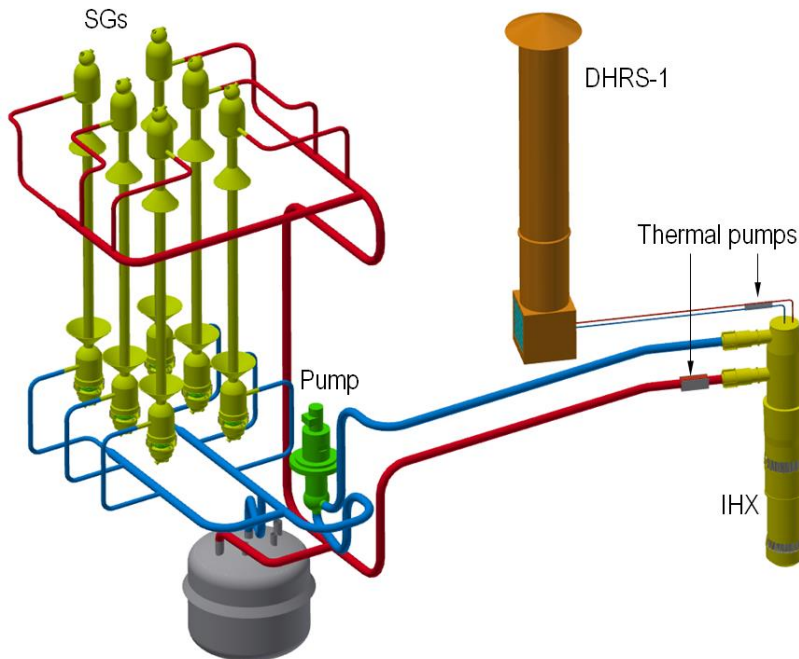

Figure 2: General view of one ESFR secondary loop

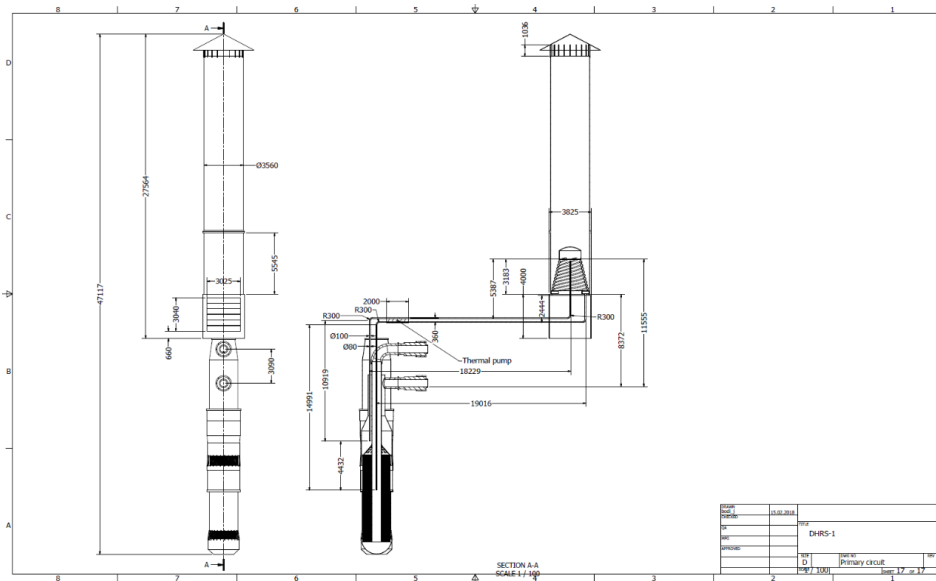

Figure 3: Example of drawing of passive DHRS-1 connected to IHX

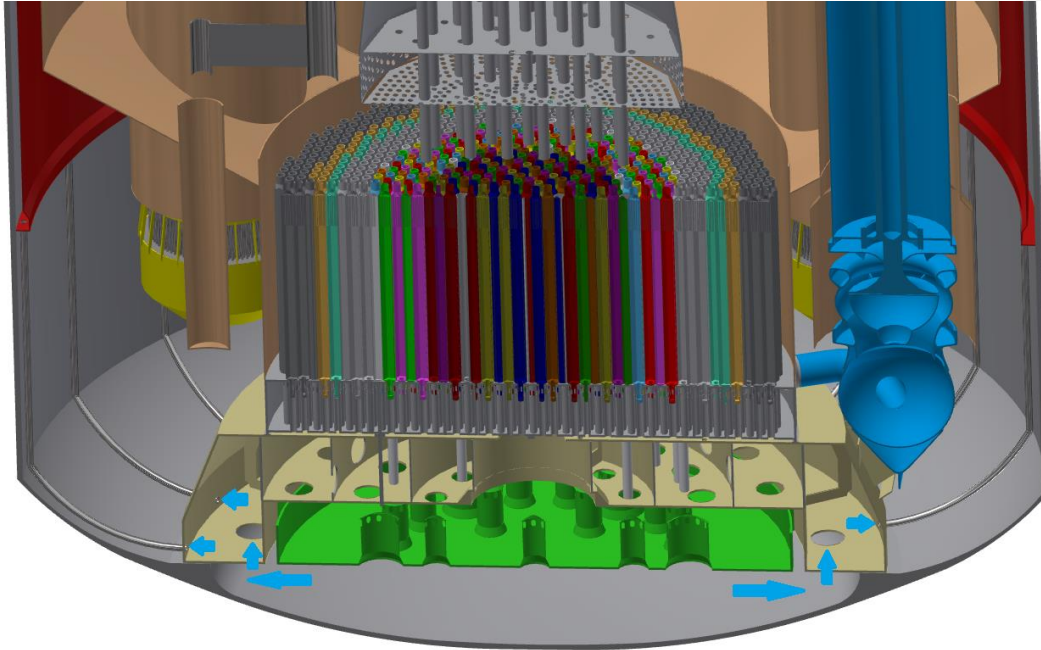

Figure 4: Lower part of the primary system

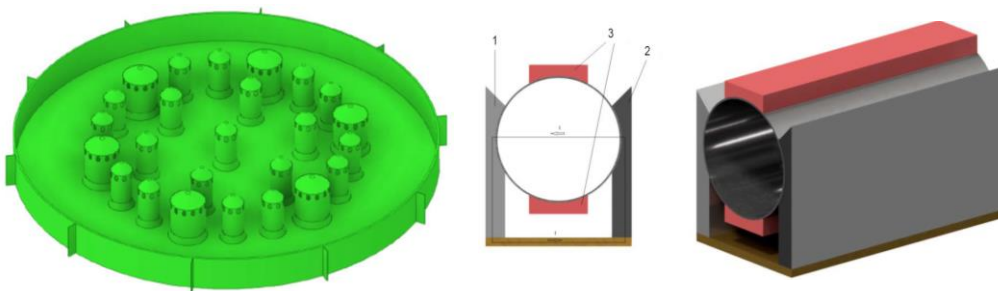

Figure 5: (a) Core catcher concept and (b) concept of thermal pump for secondary system  
 (1 – Alumel; 2 – Chromel; 3 – Permanent magnet)

### Passive and intrinsic safety

As a reminder, the passive and intrinsic safety of ESFR relies on the following safety measures:

- Passive control rods that shutdown the reactor when the selected thresholds are reached by physical parameters (coolant temperature and/or flowrate).
- Low sodium void reactivity effect in particular in case of severe accidents, e.g. ULOF.
- Passive decay heat removal by DHRS by 12 independent loops (6 DHRS-1 and 6 DHRS-2) in natural convection, using only atmospheric air as a final heat sink.
- Thermal pumps to increase the DHRS efficiency.

- Large thermal inertia and long grace time before necessity of operator action, even in case of loss of feedwater and loss of electricity supply.



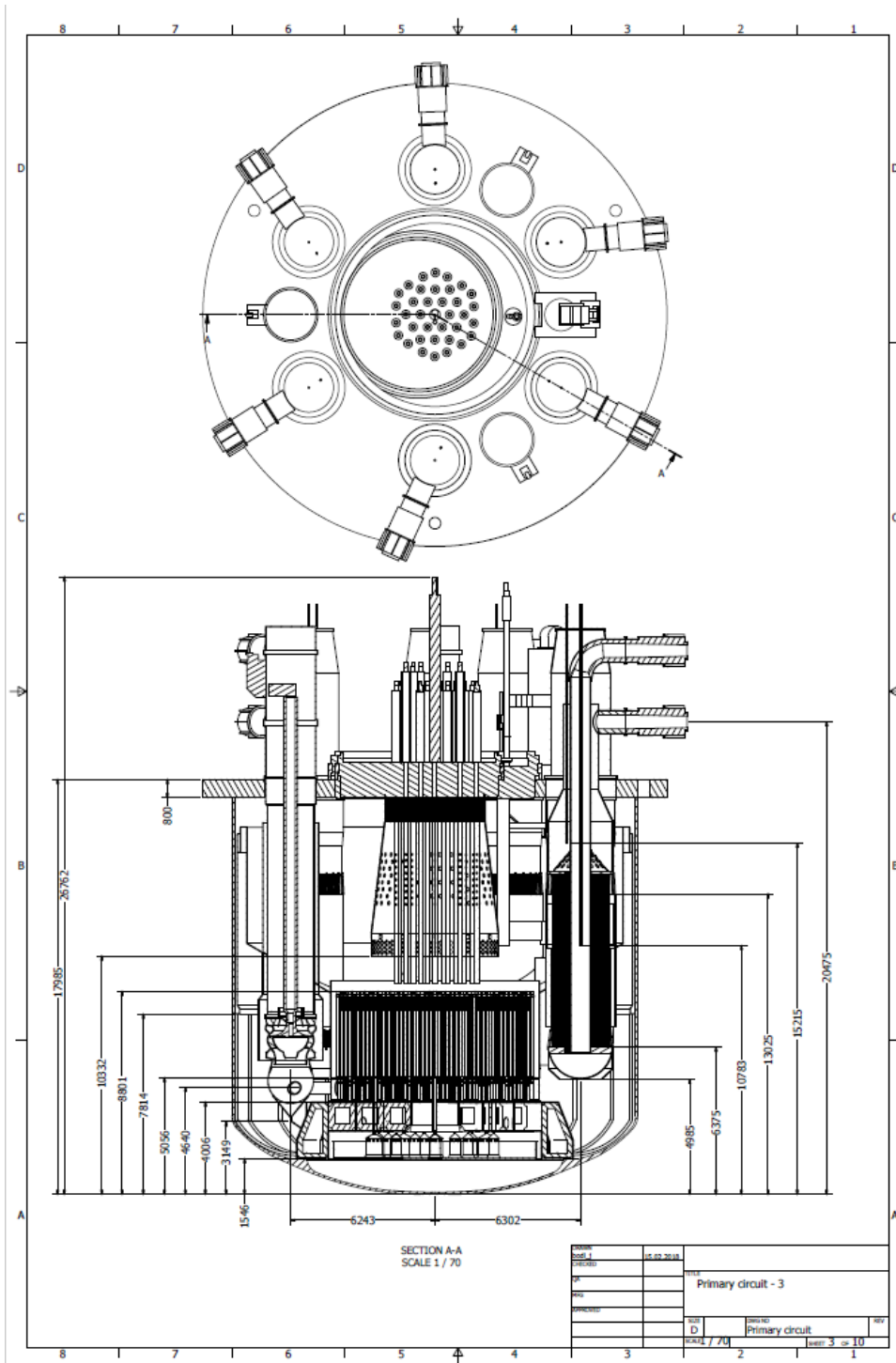

Figure 6: Primary circuit drawing

## Status of evaluations of safety measures at the end of 2018 and near-term plans

All drawings of the plant components are done and presented in [14] and [77]; see e.g. one of the primary system drawings in [Figure 6](#). On the basis of these drawings, several calculations have been started in 2018:

- The reactor pit conceptual design have been proposed and preliminary CFD calculations of heat transfer capabilities including DHRS-3 efficiency have been performed by JRC using ANSYS CFX [44].
- Calculations of the DHRS-2 efficiency under natural convection conditions have been started by EDF using the CATHARE code.
- Calculations of decay heat removal from the corium located in the core catcher under conditions of the primary sodium natural convection have been started by CIEMAT.
- The whole reactor thermal-hydraulic model was developed using the TRACE system code by PSI.
- The compliance of the DHR systems with safety requirement and overall DHR architecture will be verified by Framatome in 2019.
- Evaluation of the thermal pump concept and efficiency will start in 2019.

Mis en forme : Police :(Par défaut)  
Arial, Non Gras

Mis en forme : Police :(Par défaut)  
Arial, Non Gras

Mis en forme : Police :(Par défaut)  
Arial

Mis en forme : Police :(Par défaut)  
Arial, Non Gras

## R&D for the future. Cost challenge

Another advantage of the design simplification is the cost reduction. Today SFR has a handicap of being more expensive than PWR due to the fact that the existing prototypes do not benefit from the economy of scale, but also due to some intrinsic issues, e.g. big intermediate loops necessary for this type of reactor. An analysis made during the EFR project by comparing the masses of materials between PWR and SFR has identified a cost difference of about 30%. The design simplifications proposed in the ESFR-SMART project should reduce this cost difference due to:

- Suppression of dome (or polar table) and safety vessel (functions taken over by the reactor pit) with improvement of primary sodium containment due to a massive metallic roof and other measures;
- Suppression of a dedicated DHR system with independent sodium circuits in the primary vessel (no supplementary sodium circuits to manage).

Other modifications could be studied in the future to optimize the secondary circuits and reduce their cost, especially, for the steam generator modules which are large in size (more than 30 meters) and requires big and costly secondary buildings. The study of the new compact steam generator designs with sodium/water plates shows theoretical possibility to design modules of about one meter able to produce steam at 140 bars. This type of modules would allow re-designing of the secondary loops with a potential reduction in weight, volume and cost. The use of new materials with lower thermal expansion coefficients would also allow some reduction of the length of the secondary pipes and corresponding costs.

Other hand, some additional R&D will be necessary to validate the CFV core concept, the mitigation system as corium behaviour in interaction with primary sodium and the new passive systems (passive control rod, thermal pumps, etc.) to demonstrate their efficiency. For example, thermal pumps (see [Figure 5](#)) are robust devices. A magnetic field is created by permanent magnets. An electric current is created by thermoelectric elements. The thermal pump creates a pressure head and increases flowrate. This system was studied and operated on loops in the 80s. It was used in the SILOE reactor as a pump for the test loops. Technological studies and some tests would be necessary so as to design and validate these devices.

Mis en forme : Police :(Par défaut)  
Arial

All these studies should allow having a better understanding of the additional cost reduction for SFR with the objective of PWR cost. In addition we have to take in account the cost advantages of the SFR fuel cycle based on the use of available depleted uranium and plutonium obtained by the PWR spent fuel reprocessing. Finally the cost analysis should take into account ecologic advantages of using this reactor type able to provide electricity for millenniums using as fuel available waste (spent fuel) and without need of uranium mines or enrichment capacities.

## Conclusions

The new safety measures proposed for the European Sodium Fast Reactor in frame of the ESFR-SMART project are briefly described in the paper and illustrated by the key drawings. More details are provided in the corresponding deliverable [14]. “Simplification” and “passive safety” were two key goals we aimed at while selecting the design modifications. The proposed design relies on technical measures of different degree of validation and in most of cases additional studies will be conducted to verify, confirm or modify the proposed measures. These studies will be done in the ESFR-SMART project or proposed for the follow-up project. In particular, compliance of the proposed ESFR design modifications with the safety requirements updated after the Fukushima accident will be checked in the project. This analysis will validate the relevance of the whole design to the final safety objectives.

Mis en forme : Police :(Par défaut)  
Arial, Non Gras

## Acknowledgement

The research leading to these results has received funding from the EURATOM research and training programme 2014-2018 under grant agreement No 754501.

## References

1. J. Guidez, J. Bodi, K. Mikityuk , S. Beils, “Specification of the new system safety measures” EU ESFR-SMART project, Deliverable D1.1.3, 16.07.2018.
2. J. Guidez, L. Costes, P. Gauthé, P. LoPinto, S. Beils, B. Carluéc, E. Courtin, L. Bourgue, “Application of practical elimination approach for GEN IV reactors design”, GIF Symposium UIC, Paris, France, October 16-17, 2018.
3. A. Rineiski, C. Meriot, M. Marchetti, and J. Krepel, Core Safety Measures in ESFR-SMART, Proc. of PHYSOR 2018, Cancun, Mexico, April 22-26, 2018.
4. J. Guidez, A. Gerschenfeld, E. Girardi, K. Mikityuk , J. Bodi, A. Grah, “European Sodium Fast Reactor: innovative design of reactor pit aiming at suppression of safety vessel”, 2019 International Congress on Advances in Nuclear Power Plants (ICAPP 19), Juan-les-Pins, France, May 12-15, 2019.
5. J. Guidez and G. Prêle “Superphenix. Technical and scientific achievements”, Edition Springer, 2017, ISBN 978-94-6239-245-8.
6. J. Guidez “Phenix experience feedback”, Edition EDP Sciences, 2014, EAN13: 9791092041057.
7. J. Bodi, K. Mikityuk, A. Ponomarev, J. Guidez, “Use of CAD models in ESFR-SMART project”, GIF Symposium UIC, Paris, France, October 16-17, 2018.
8. P. Gauthé, J. Guidez , S. Beils, B. Carluéc,, L. Bourgues, “Considerations on GEN IV safety goals and how to implement them in future Sodium-cooled Fast Reactors.” , AIEA "International Conference on Fast Reactors and Related Fuel Cycles (FR17), Yekaterinburg, Russian Federation, June 26-29, 2017