

Towards a Direct Measurement of the Neutrino Mass

The KATRIN experiment

Neutrino Telescopes / Venice / 20.03.2019
Stephan Dyba for the KATRIN collaboration



Outline

- Neutrino and mass measurements
- KATRIN experiment
 - Tritium source and Transport
 - Spectrometer and Detector
- Spectrometer Background
- Milestones
- System stability and next steps

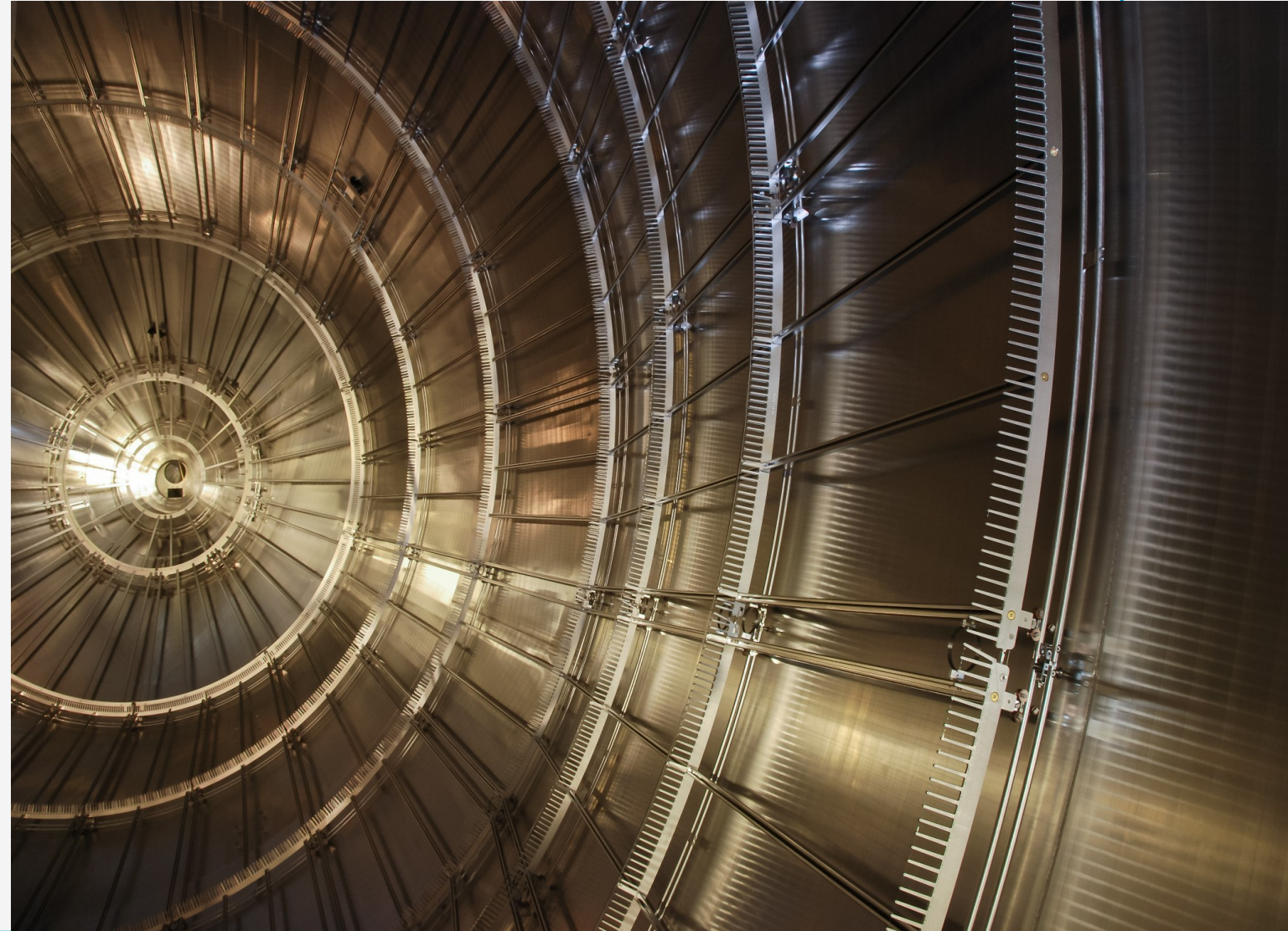

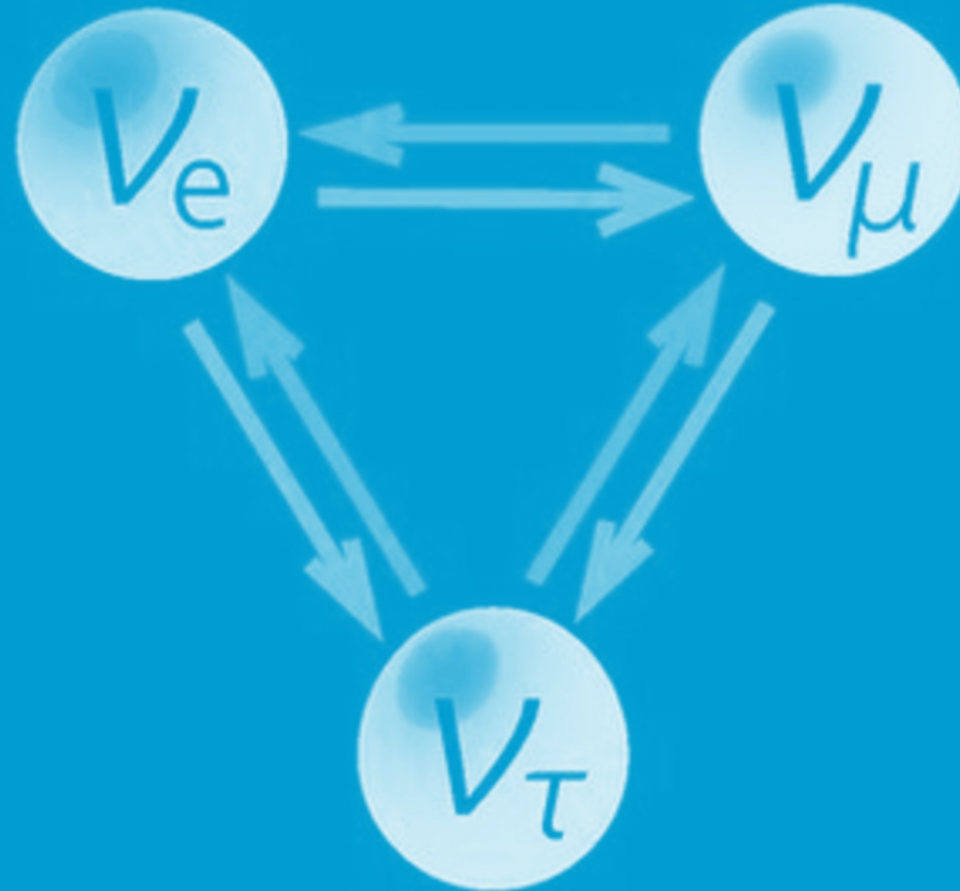

Neutrinos and mass measurements

Neutrinos and the Standard Model of Particle Physics

Standard Model of particle physics describes:

- 12 fermions and 12 bosons as mediators of the interactions
- Includes 3 neutrinos (ν_e, ν_μ, ν_τ)
- Neutral particle, spin $1/2$
- Weak interacting

Standard Model mass terms:

Left and right handed particles couple to Higgs

↪ neutrino only left handed

↪ Yukawa coupling to Higgs not existing in SM

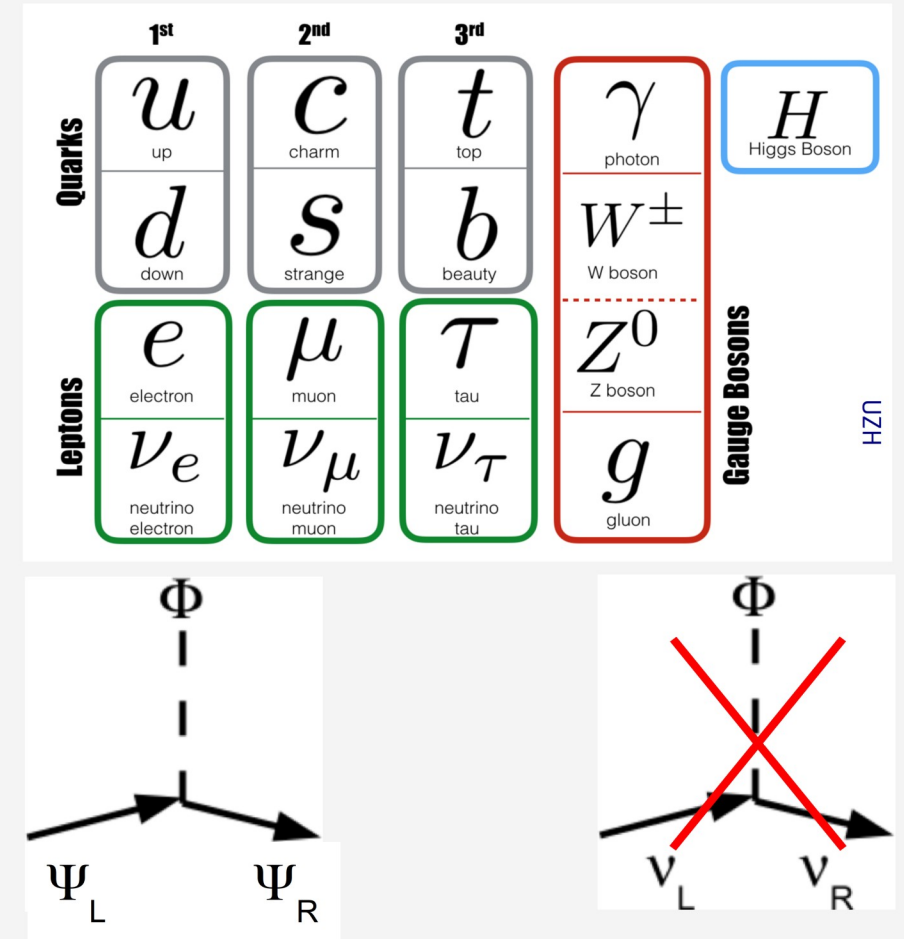

Discovery of neutrino oscillation

Neutrino oscillation observed:

- Nobel price 2015: T. Kajita and A. B. McDonald
- Neutrinos are massive $\implies m(\nu) \neq 0$
- Flavor eigenstates \neq mass eigenstates
- Connected by unitary mixing matrix $\implies \begin{pmatrix} \nu_e \\ \nu_\mu \\ \nu_\tau \end{pmatrix} = U_{\text{PNMS}} \cdot \begin{pmatrix} \nu_1 \\ \nu_2 \\ \nu_3 \end{pmatrix}$

Evidence for oscillations found in experiments

- **Atmospheric**
(Kamiokande, Super-Kamiokande, IceCube, ANTARES)
- **Accelerator**
(K2K, T2K, MINOS, OPERA, MiniBoone)
- **Solar**
(Homestake, Gallex, Sage, Super-Kamiokande, SNO, Borexino)
- **Reactor**
(KamLAND, CHOOZ, Daya Bay, Double CHOOZ, RENO)

Neutrinos and mass measurements

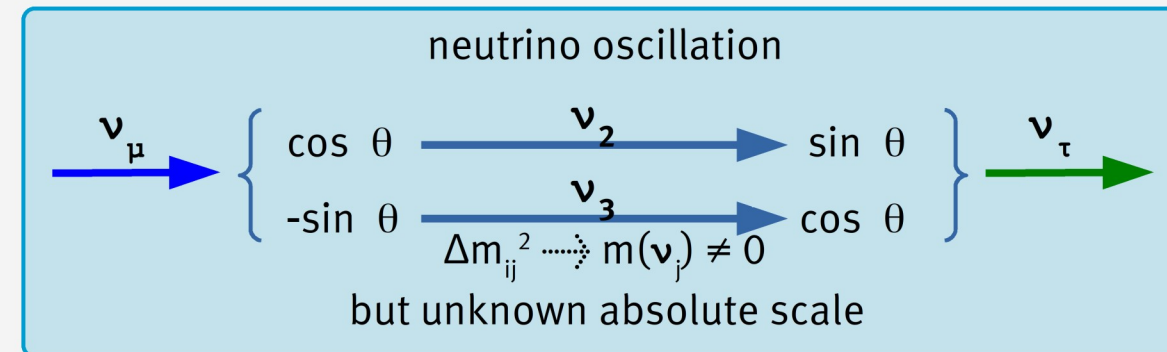

Determine mass property of neutrino

From oscillation experiments:

- Three mixing angles: $\theta_{23}, \theta_{12}, \theta_{13}$
- Two mass differences: $|\Delta m_{13}^2|, \Delta m_{12}^2$

↪ cannot measurement absolute value

Need dedicated experiments:

- Measure mass scale
- Neutrino mass degenerated?
- structure formation / e.g. seesaw type II
- Hierarchical ordered masses?
- smallness of masses / e.g. seesaw type I

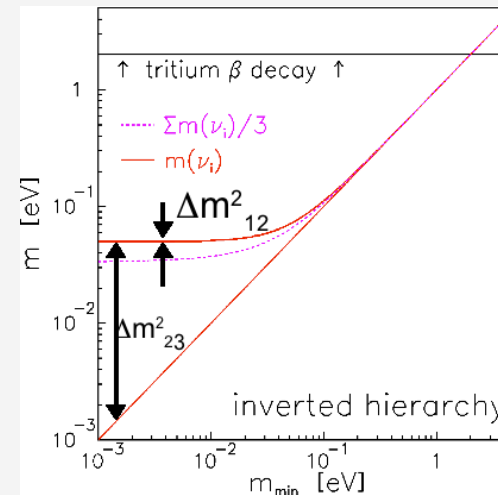
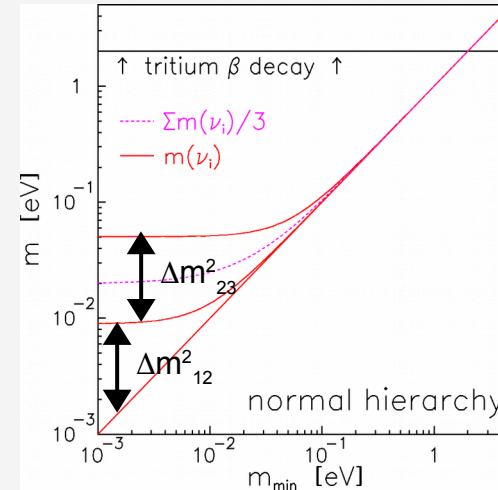

Neutrinos and mass measurements

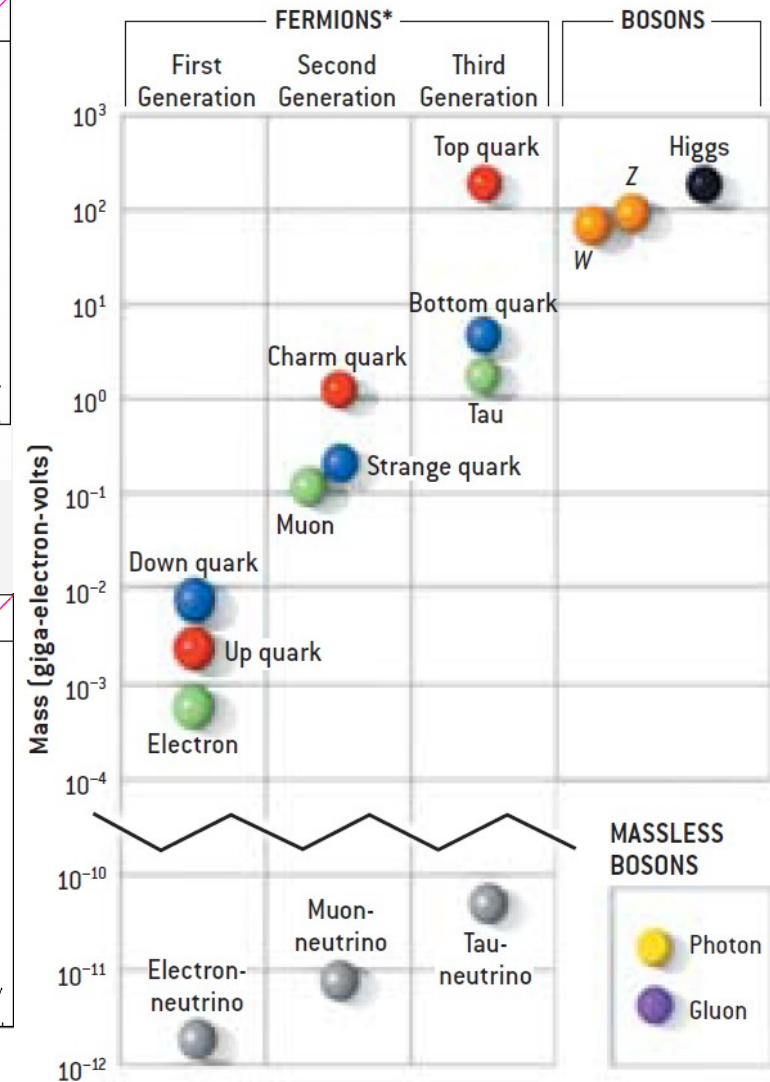

Approaches to measure the neutrino mass

Neutrino Mass Measurements

model independent, kinematics

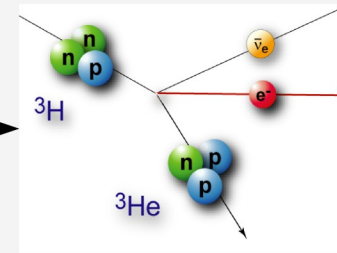

β -decay: absolute ν -mass

status: $m_\nu < 2.3$ eV

potential: $m_\nu \approx 0.2$ eV

e.g.: KATRIN, Project-8, ECHO
HOLMES, NuMECS

model-dependent (CP-phases)

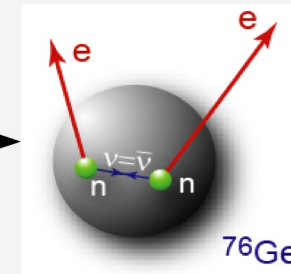

$0\nu\beta\beta$ -decay: eff. Majorana mass

status: $m_{\beta\beta} < 0.31$ eV

potential: $m_{\beta\beta} \approx 20$ -50 meV

e.g.: GERDA, CUORE, EXO, SNO+, Majorana,
Nemo 3, COBRA, KamLAND-Zen

model dependent, analysis of CMB and structure formation data

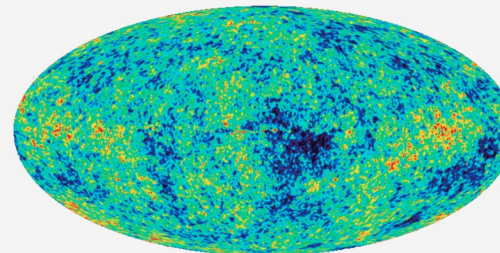

cosmology: ν hot dark matter Ω_ν

status: $\Sigma m_\nu < 0.23$ eV

(Planck Collaboration, A&A 594 (2016) A13)

possible signal: $\Sigma m_\nu = 0.11 \pm 0.03$ eV

(Emami et al., arXiv:1711.05210)

Direct determination of neutrino mass

$$\frac{d\Gamma}{dE} = C p(E+m_e)(E_0-E)\sqrt{(E_0-E)^2-m_{\nu_e}^2} F(Z+1, E)\Theta(E_0-E-m_{\nu_e})S(E)$$

$$C = \frac{G_F^2}{2\pi^3} \cos^2 \theta_C |M|^2$$

$$m_{\nu_e} = \sqrt{\sum_{i=1}^3 |U_{ei}|^2 m_i^2}$$

(modified by final state distribution, recoil corrections, radiative corrections, ...)

Need:

low endpoint energy
very high energy resolution &
very high luminosity &
very low background

→ Tritium ^3H

→ MAC-E-Filter

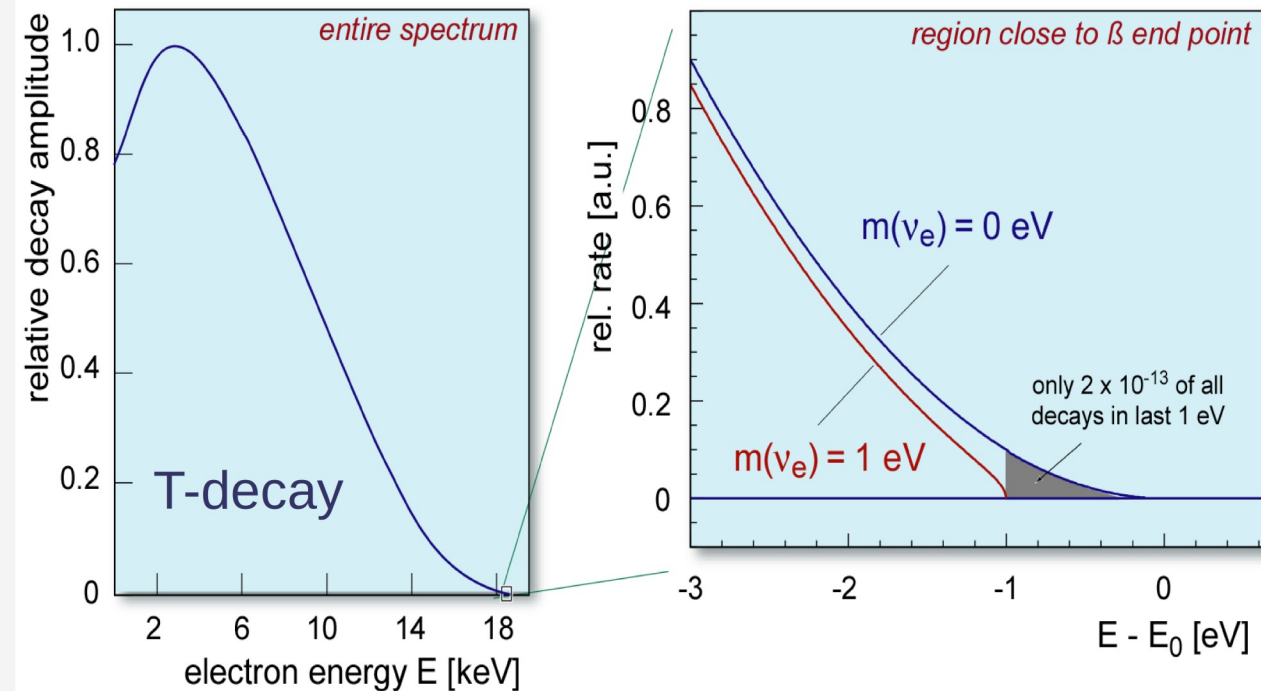



The Karlsruhe Tritium Neutrino experiment (KATRIN)

cali-
bration

windowless
gaseous T₂ source
10¹¹ e⁻ / s

tritium pumping
& e⁻ transport
10¹⁰ e⁻ / s

pre
spec
10³ e⁻ / s

MAC-E type spectrometer
10 m diameter, 24 m length

electron
detector
< 1 e⁻ / s

Basic ideas of KATRIN:

- Windowless gaseous molecular tritium source

→ ultra-high luminosity and small systematics

- Huge spectrometer of MAC-E-Filter type

→ ultra-high energy resolution

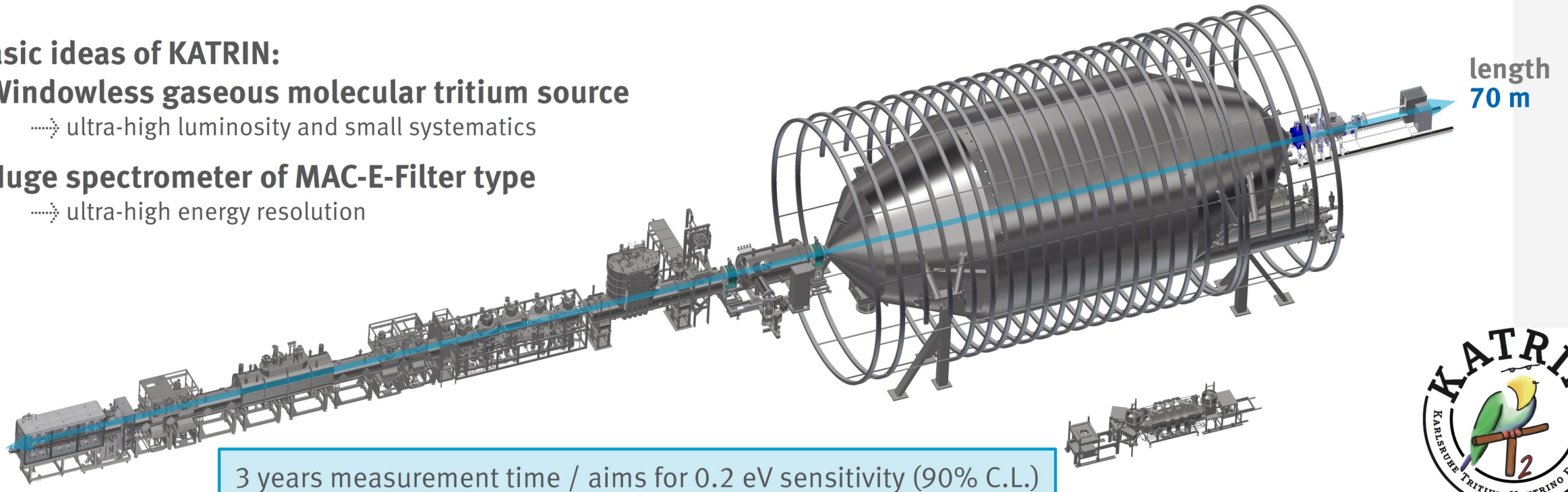

3 years measurement time / aims for 0.2 eV sensitivity (90% C.L.)



The KATRIN Collaboration



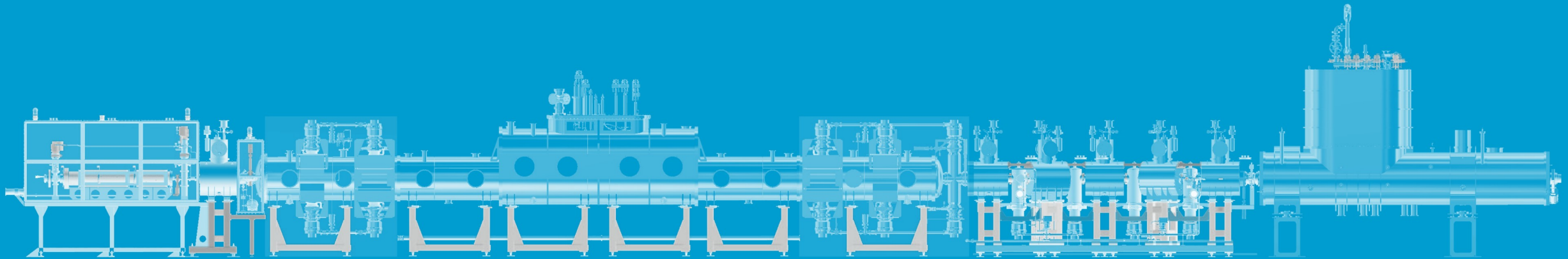

Beamline: Tritium source and Transport section

Windowless gaseous tritium source

beam tube	$\varnothing = 9 \text{ cm}$, $L = 10 \text{ m}$
guiding field	3.6 T
temperature	$T = 30 \text{ K} \pm 30 \text{ mK}$
T_2 flow rate	$5 \cdot 10^{19}$ molecules/s (40 g of T_2 / day)
T_2 purity	$95\% \pm 0.1 \%$
T_2 inlet pressure	$10^{-3} \text{ mbar} \pm 0.1 \%$
column density	$5 \cdot 10^{17} T_2 / \text{cm}^2$
luminosity	$1.7 \cdot 10^{11} \text{ Bq}$

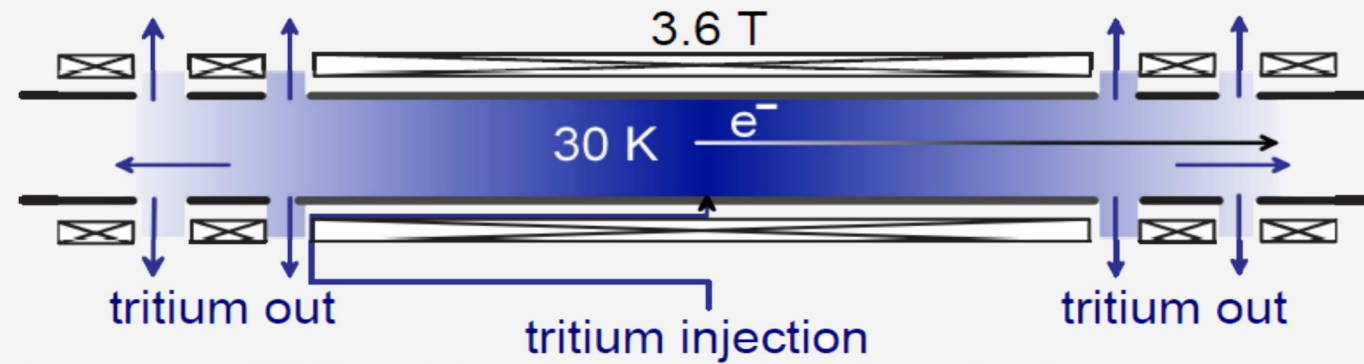
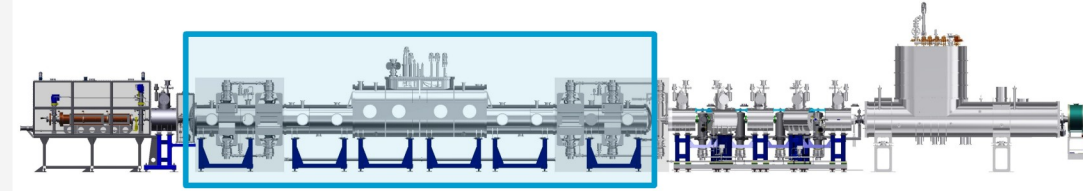

WGTS at Tritium Laboratory Karlsruhe

Tritium suppression by differential and cryo pumping

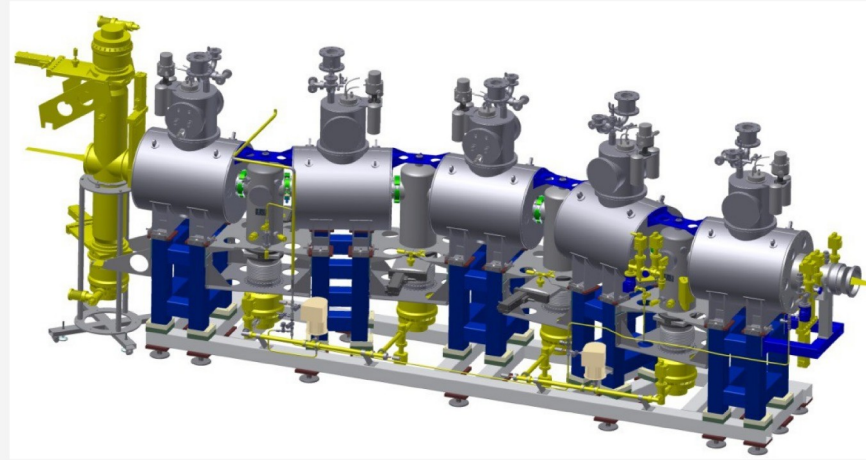
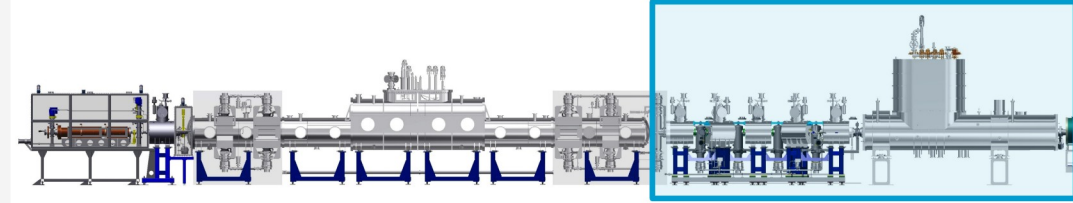

Differential pumping section

- active pumping: 4 TMPs
- Tritium retention: 10^5
- magnetic field: 5.6 T
- Ion monitoring and ion manipulation by dipole and monopole electrodes inside

Cryogenic pumping section

- based on by cryo-sorption at Ar snow at 3-4 K
- Tritium retention: $>10^7$
- magnetic field: 5.6 T

... ❖ Retention by 14 orders of magnitude

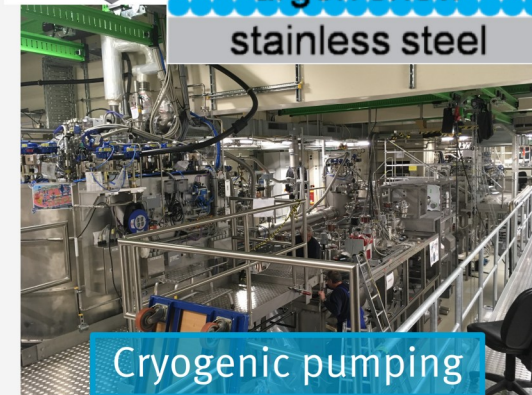
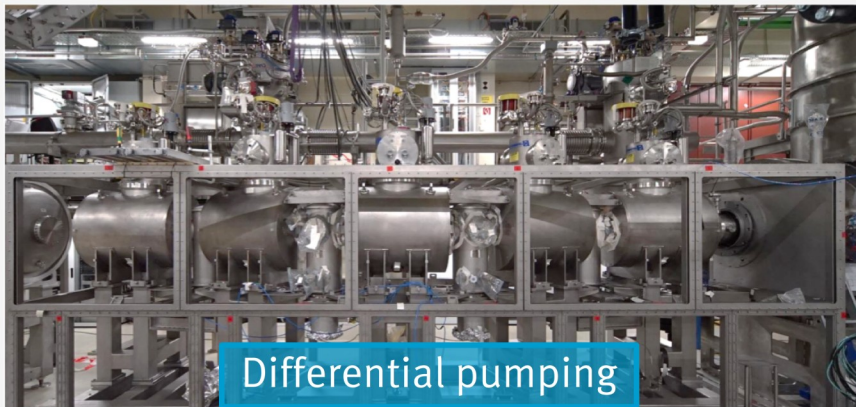
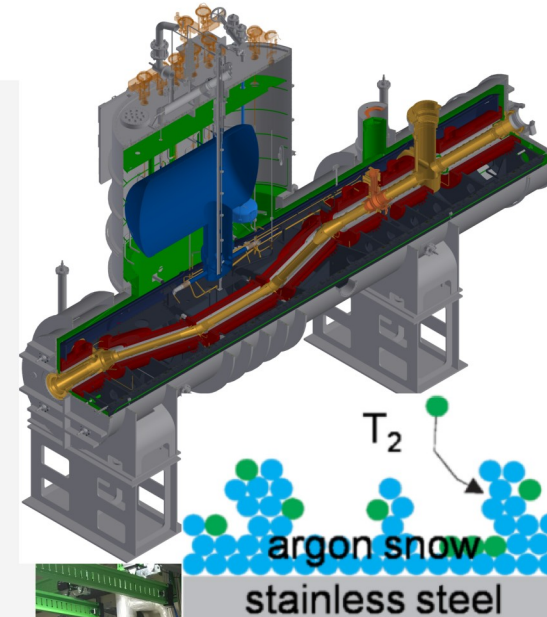

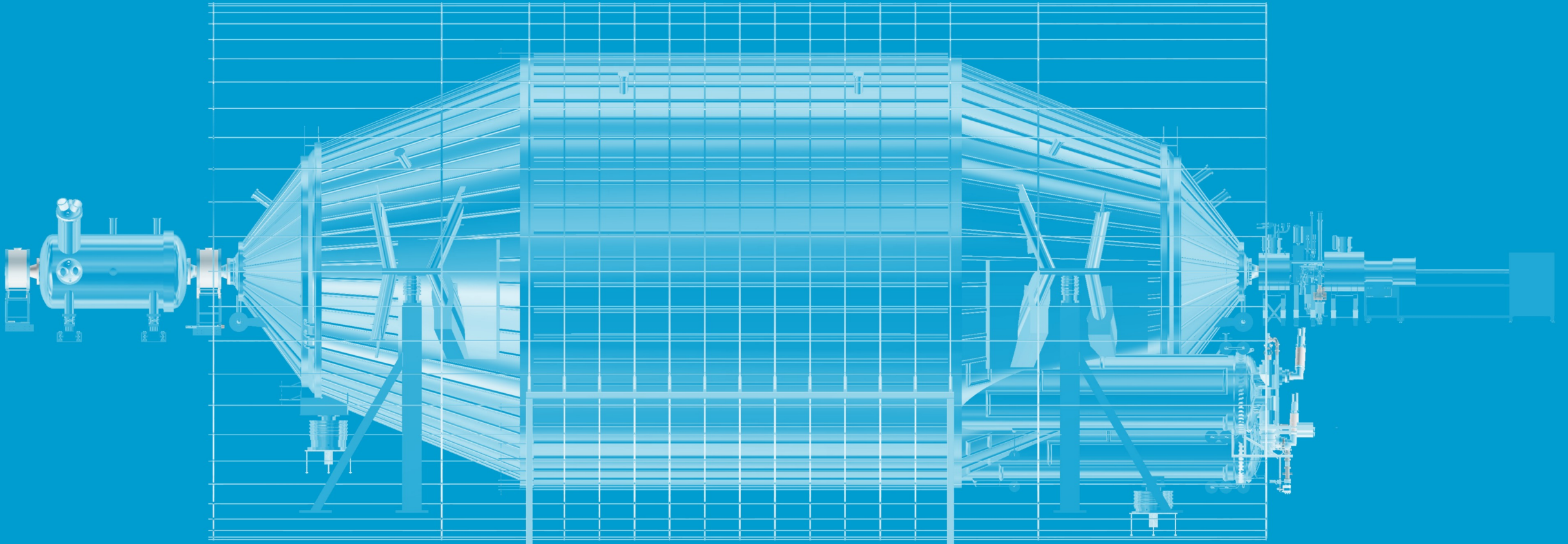

Beamline: Spectrometer and Detector section

Pre spectrometer

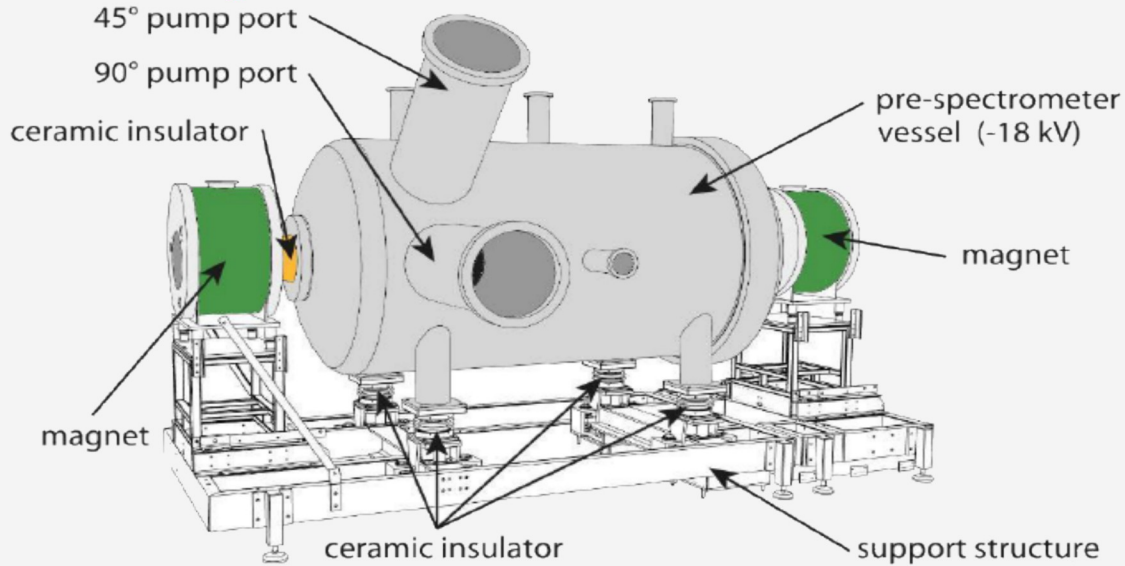

Pre-filter with a fixed potential: $E = 18.3 \text{ keV}$

Transmission of high energy electrons only

→ reduction from 10^{10} to $10^3 \text{ e}^-/\text{s}$

→ reduction of background due to scattering in the main spectrometer

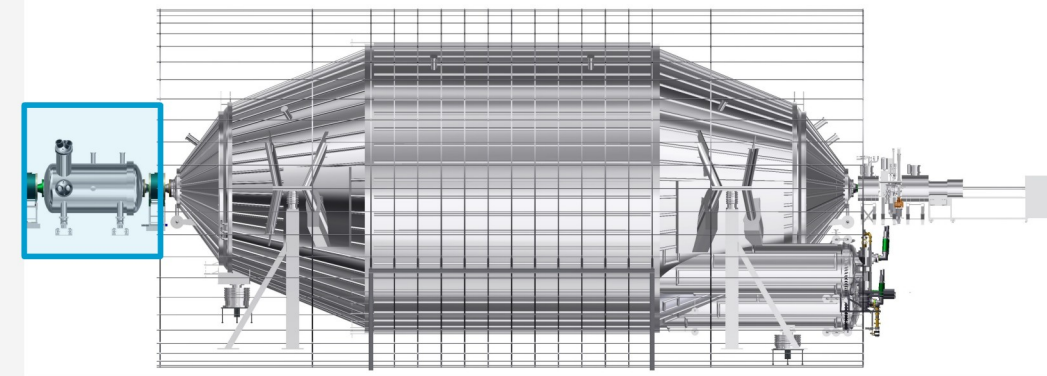

Testing ground for many systematic effects and background sources, e.g.:

Removal of Penning traps
(special electrode shapes)

Compensation of high frequency HV noise
(triode shunt circuit)

Removal of trapped particles
(dipole mode, HF excitation)

Removal of Radon induced background
(LN2 baffle)

Remaining background $\approx 20 \text{ mHz}$

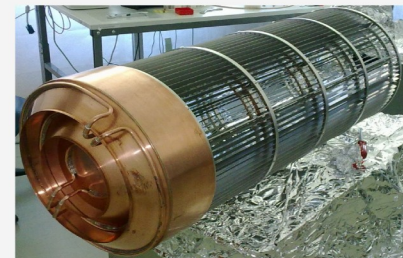
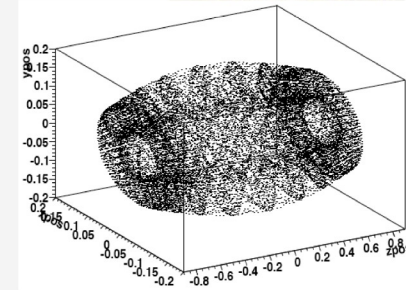
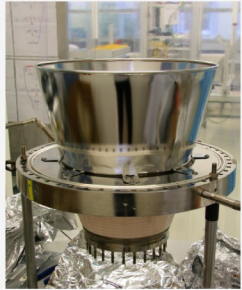

Main spectrometer

- 18.6 kV retardation voltage, $\sigma < 60$ meV
- 0.93 eV resolution
- pressure $< 10^{-11}$ mbar
- Air coils for earth magnetic field compensation
- Double layer wire electrode for background reduction and field shaping

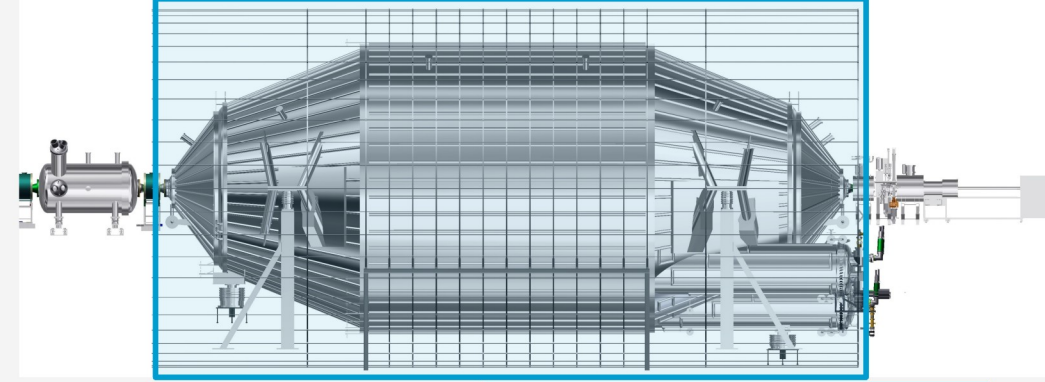

LN₂ baffles in pump ports for radon trapping

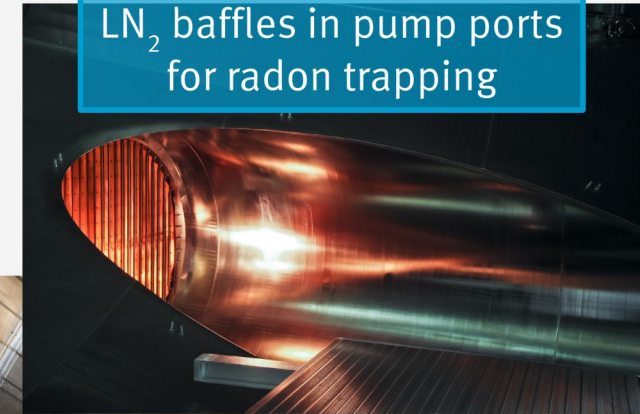

Huge spectrometer:
High energy resolution & acceptance

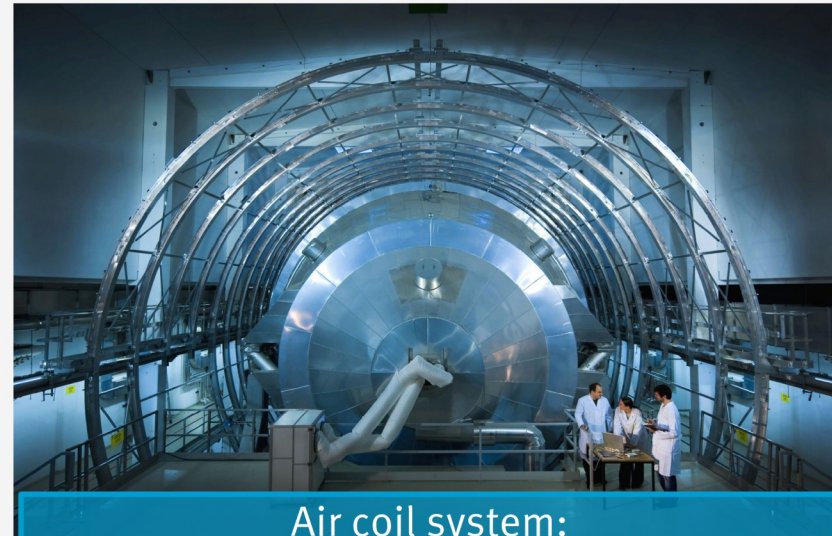

Air coil system:
Background suppression & B field shaping

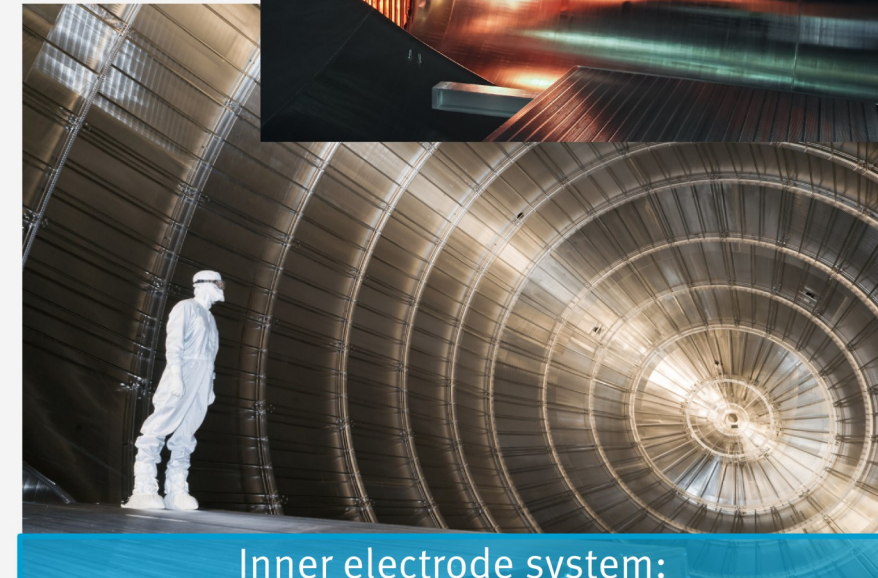

Inner electrode system:
Background suppression & potential shaping

Energy filtering with a MAC-E filter

Magnetic adiabatic collimation with electrostatic filter (MAC-E)

- Adiabatic collimation of electron momentum by magnetic field gradient (superconducting selenoid / air coils)

$$\mu = \frac{E_{\perp}}{B} = \text{const.}$$

- Energy filtering by applying electric potential (electrode structure)

$$\Delta E = qU \frac{B_{\min}}{B_{\max}}$$

- Analyzing plane defined by maximal electric potential and minimal magnetic field

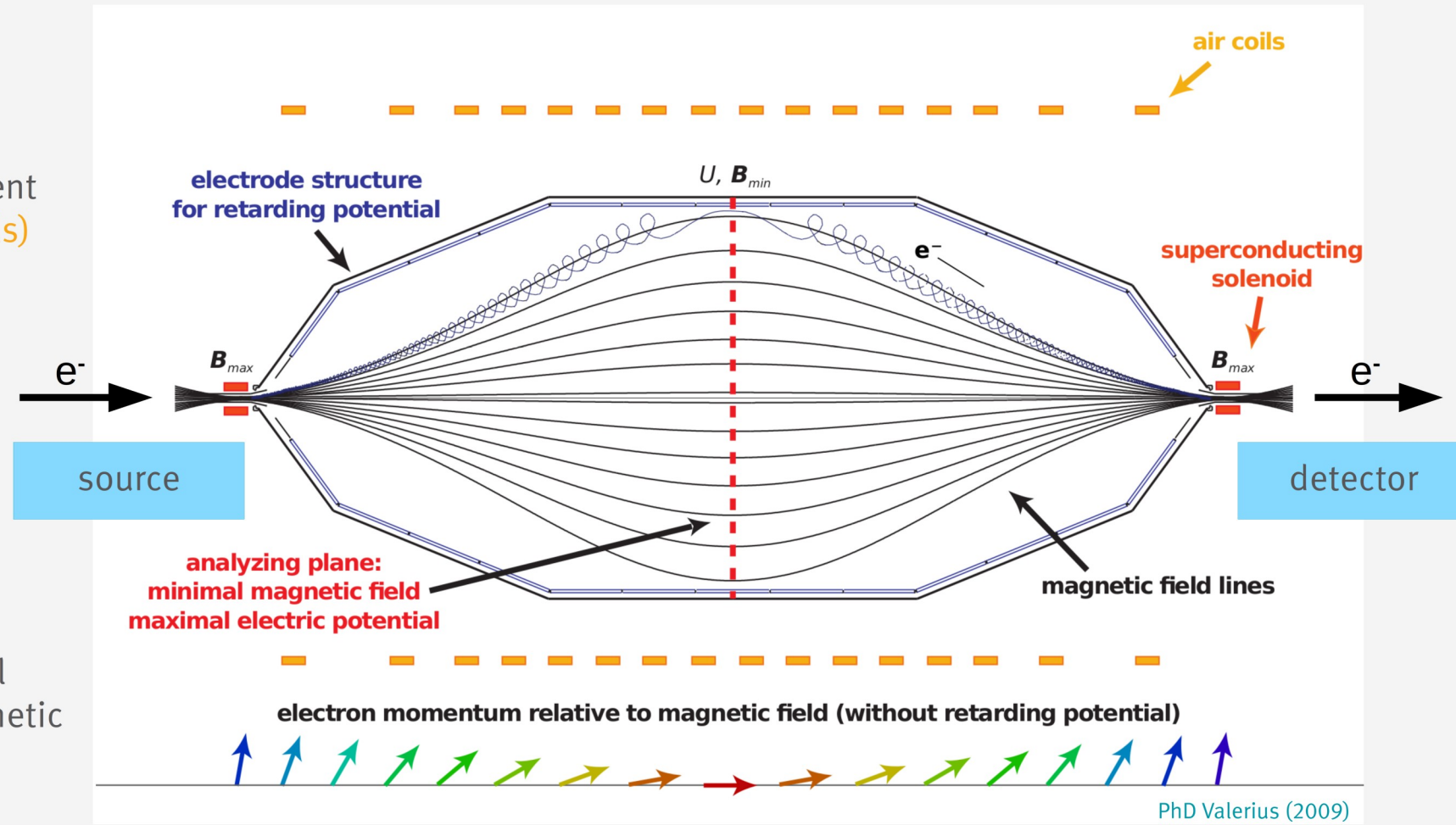

Focal Plane Detector

- segmented Si-PIN diode:
90 mm Ø, 148 pixels, 50 nm dead layer
- energy resolution ≈ 1 keV
- pinch and detector magnets up to 6 T
- post acceleration (10kV)
- active veto shield

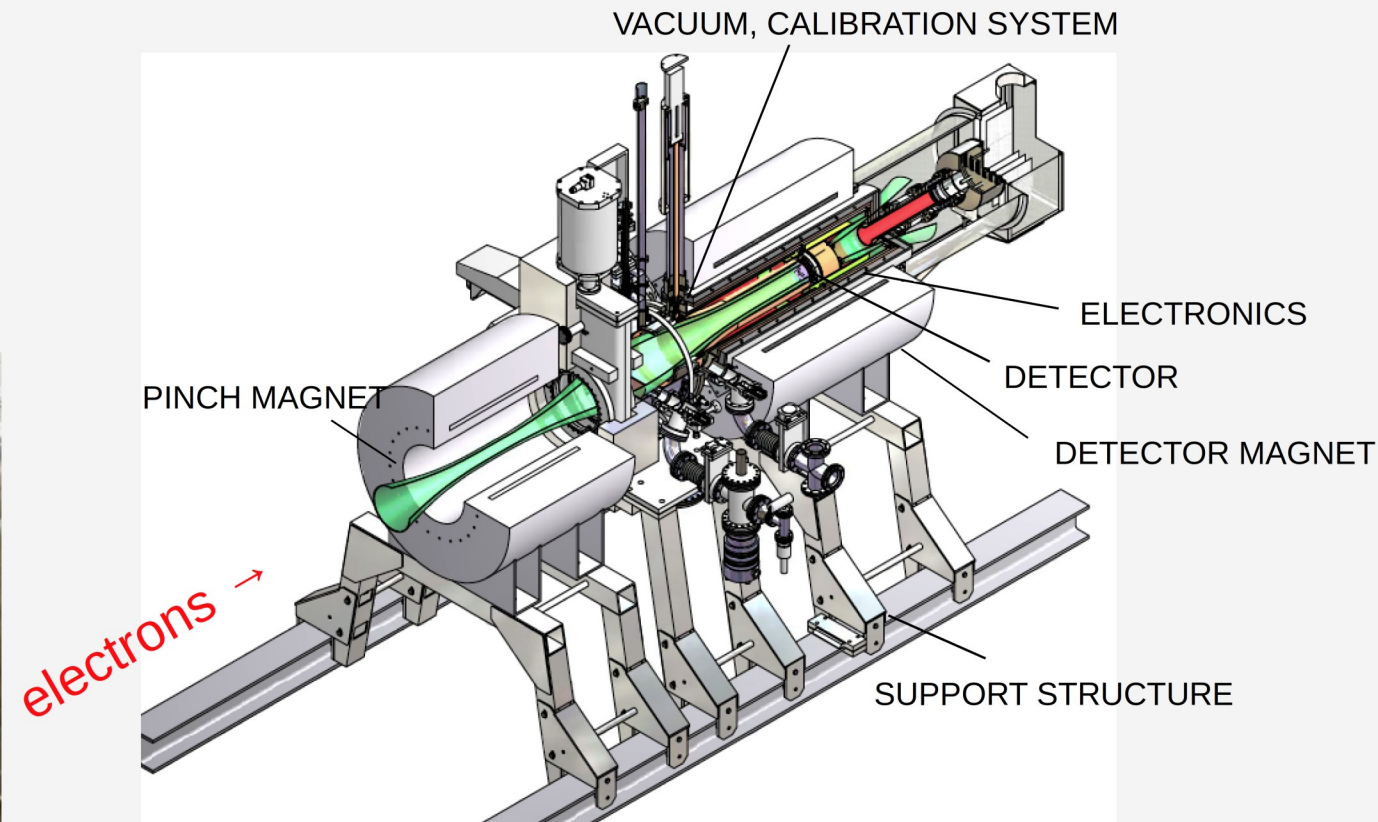
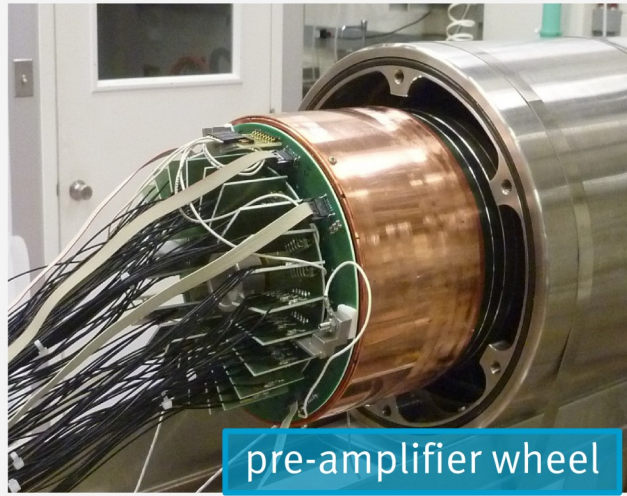
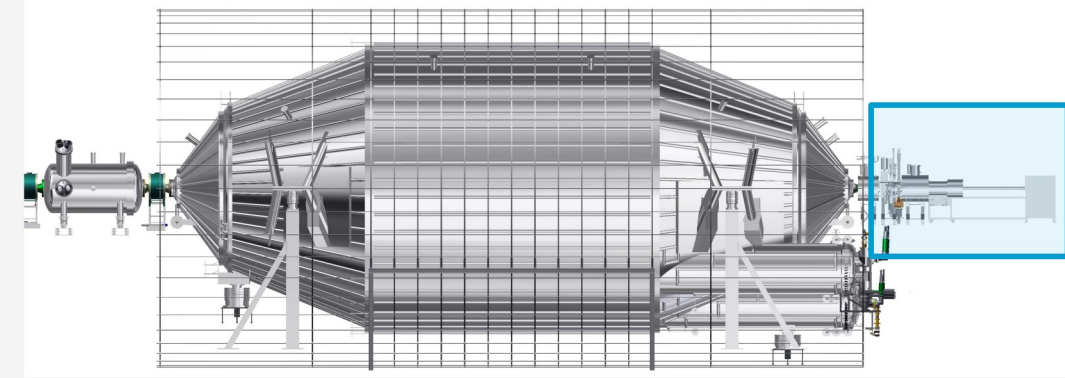

Characterizing the Main Spectrometer

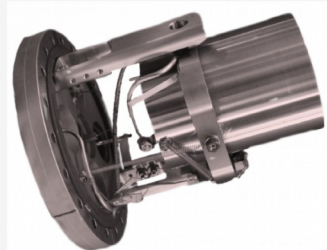
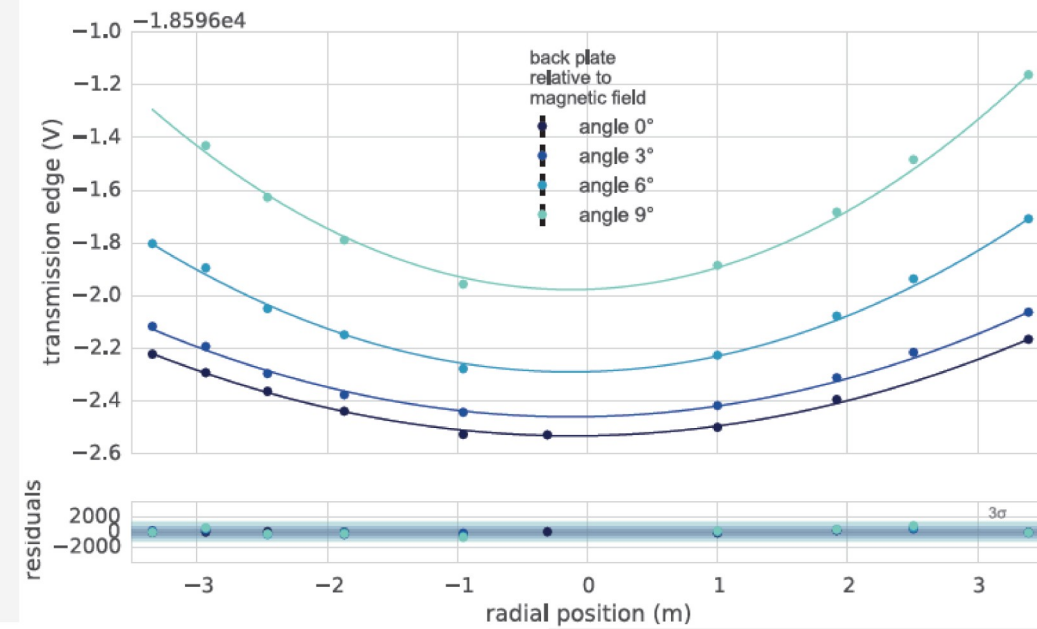
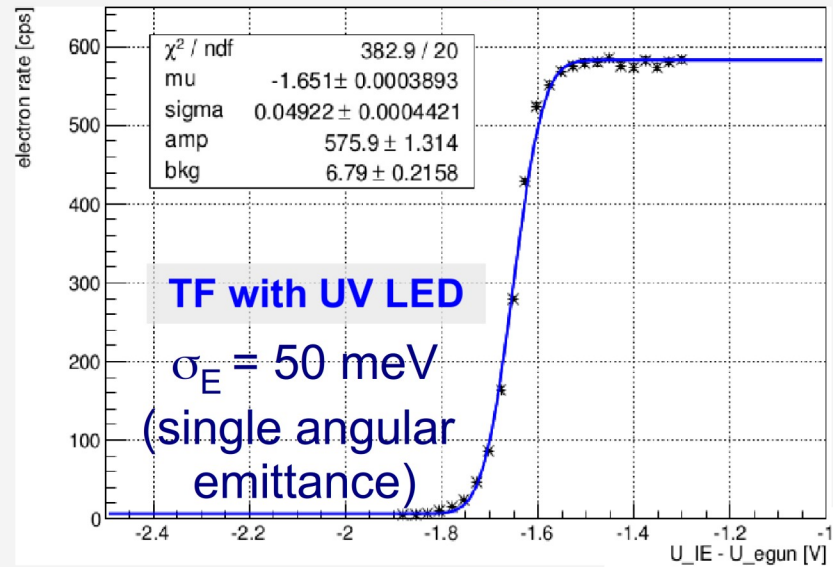

Angular-selective pulsed Photo-electron source

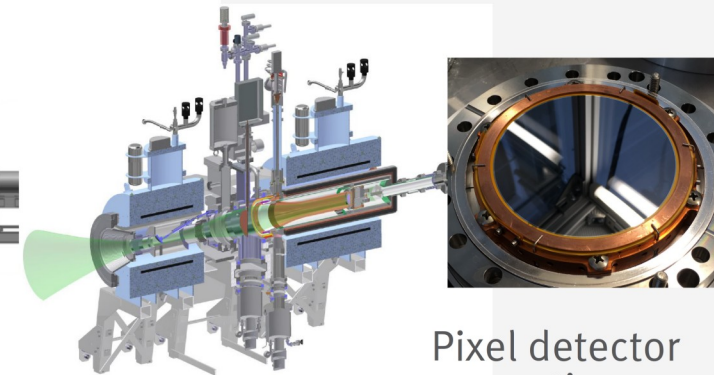
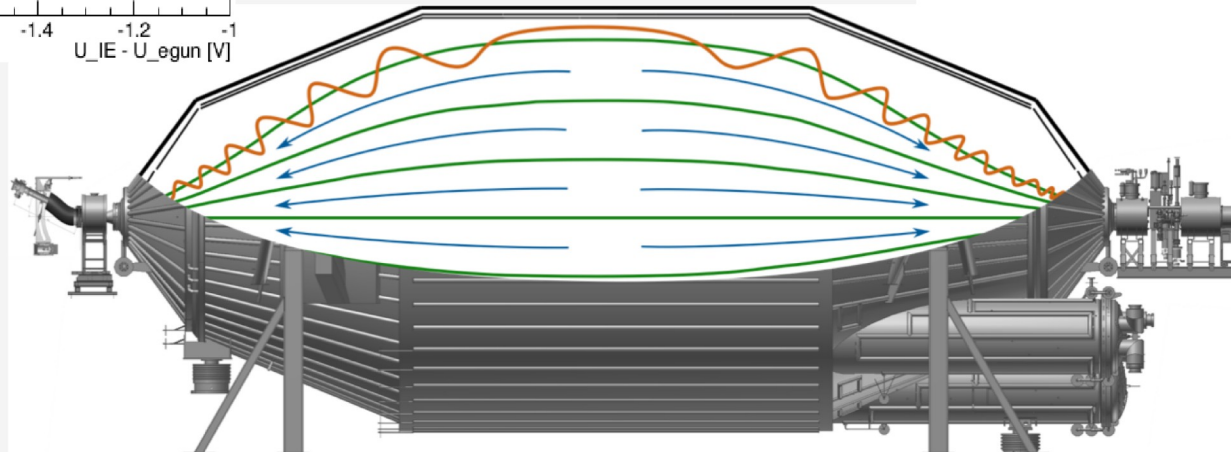

Pixel detector section

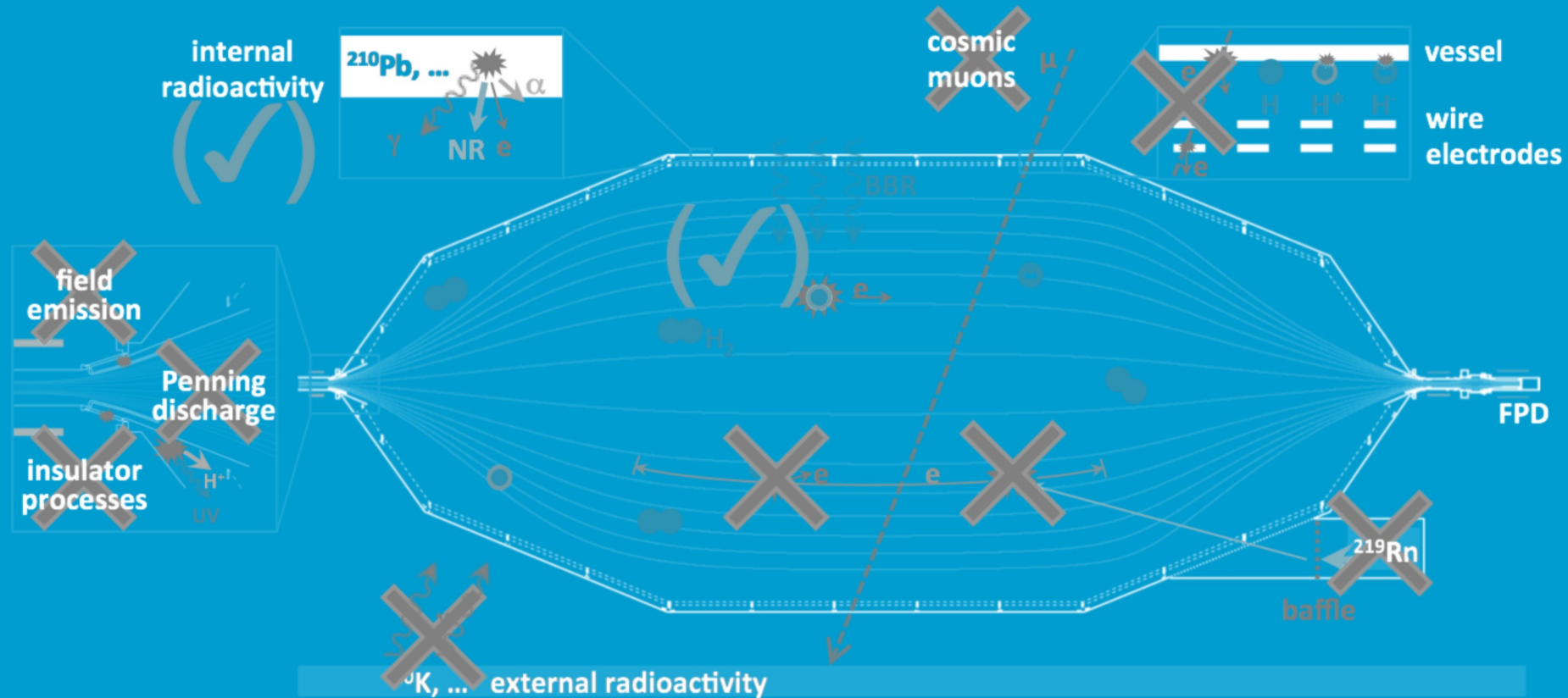

Spectrometer background

Spectrometer Background

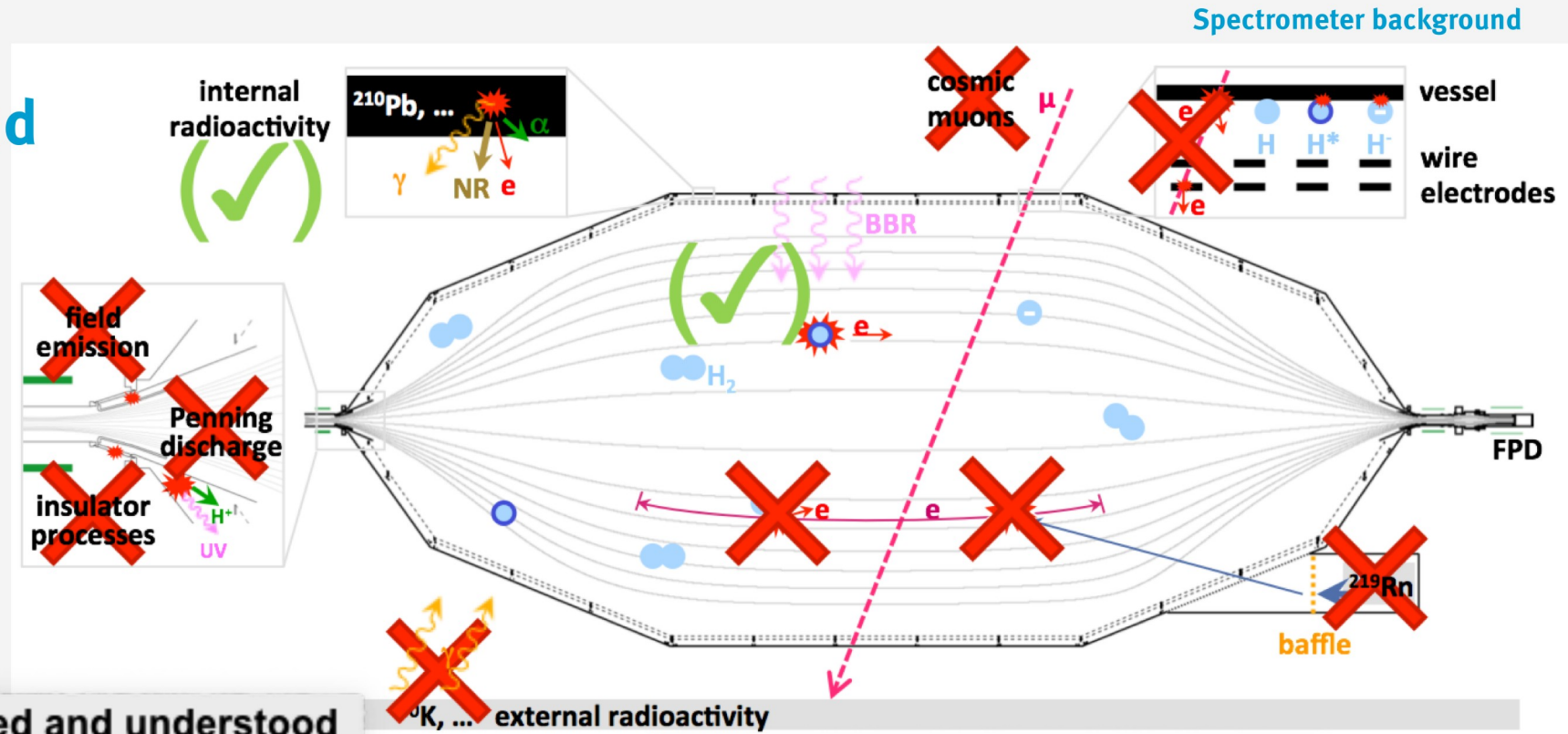

- 8 sources of background investigated and understood
- 7 out of 8 avoided or actively eliminated by
 - fine-shaping of special electrodes
 - symmetric magnetic fields
 - LN₂-cooled baffles (cold traps)
 - wire electrode grids

- 1 out of 8 remaining:
caused by ^{210}Pb on spectrometer walls (neutral H^* atoms ionised by black-body radiation in spectrometer)

Neutral decays in Spectrometer - ^{219}Rn (getter) and ^{220}Rn (artificial source)

^{219}Rn atoms:

- ^{219}Rn emanates from NEG
- stored electrons eV...keV
- bg-rate: ~ 500 mcps

countermeasure (passive):

- cryotraps in front of NEG
- 3 LN₂-cooled Cu-baffles eliminate $\sim 97\%$ of emanated ^{219}Rn atoms

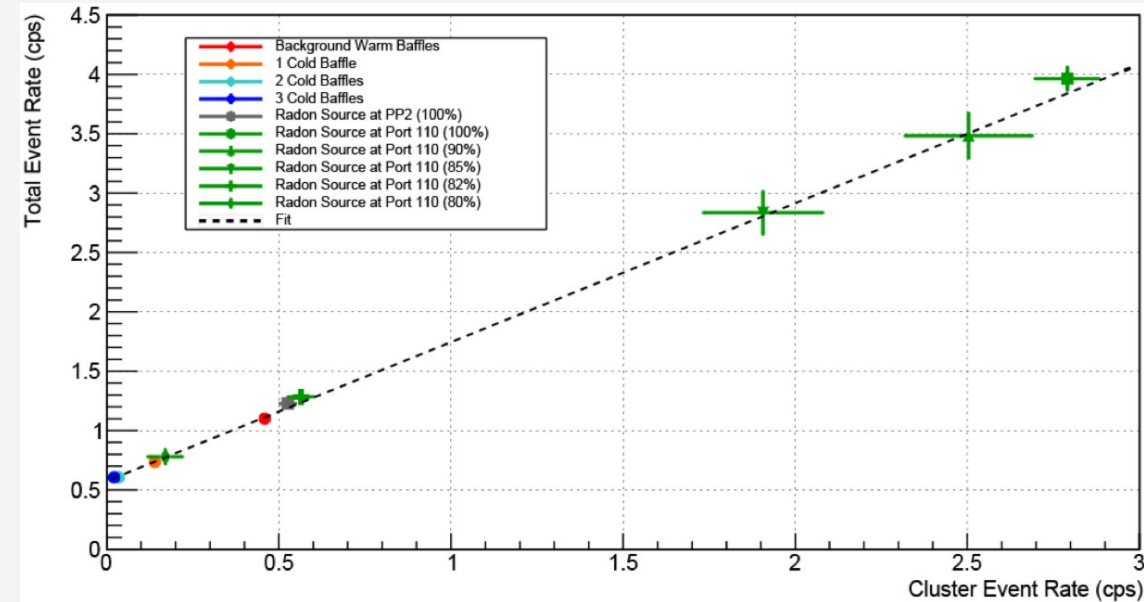
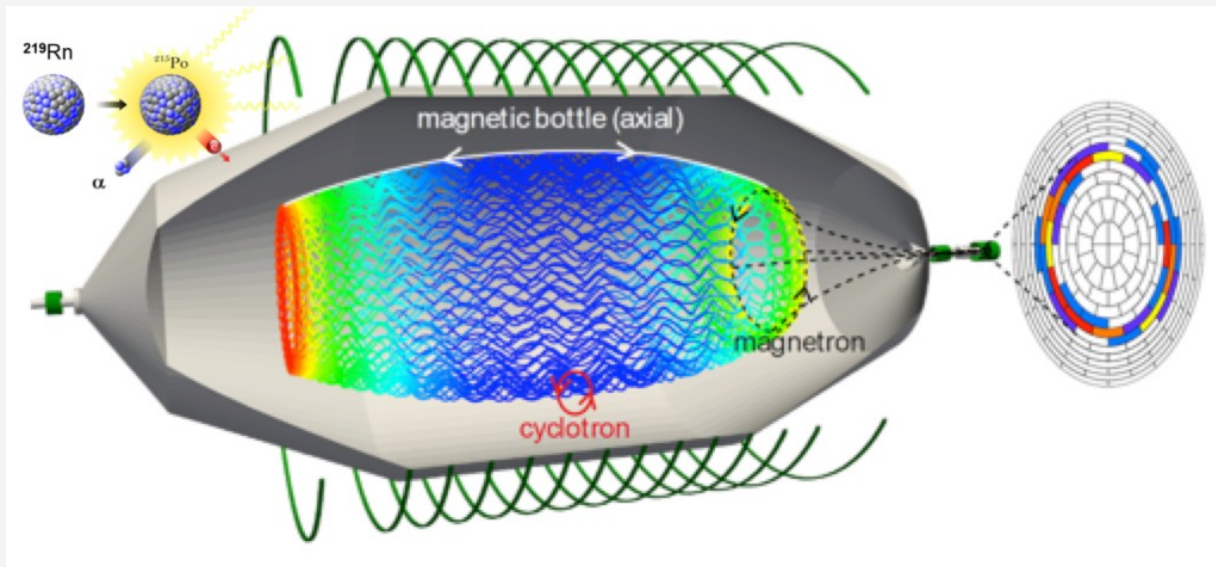

Ionization of Rydberg atoms sputtered off by alpha decays

Rydberg (or autoionising) atoms:

- ejected from walls due to ^{206}Pb recoil ions from ^{210}Po decays
- ionized by black body radiation (291 K)
- non-trapped electrons on meV-scale
 → bg-rate: ~ 0.5 cps

counter measures:

- apply stronger voltage (field ionisation) at wire electrode system
- reduce flux tube
- cover main spectrometer walls (maybe in future)

Testing this hypothesis: artificially contaminating the spectrometer with implanted short-living daughters of ^{220}Rn (and ^{219}Rn)

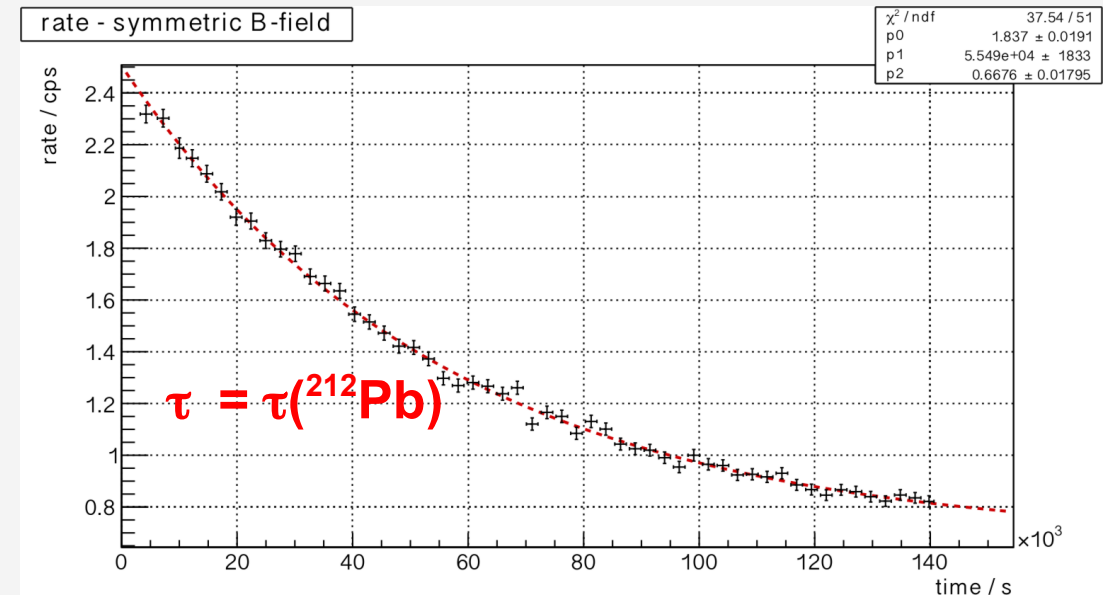
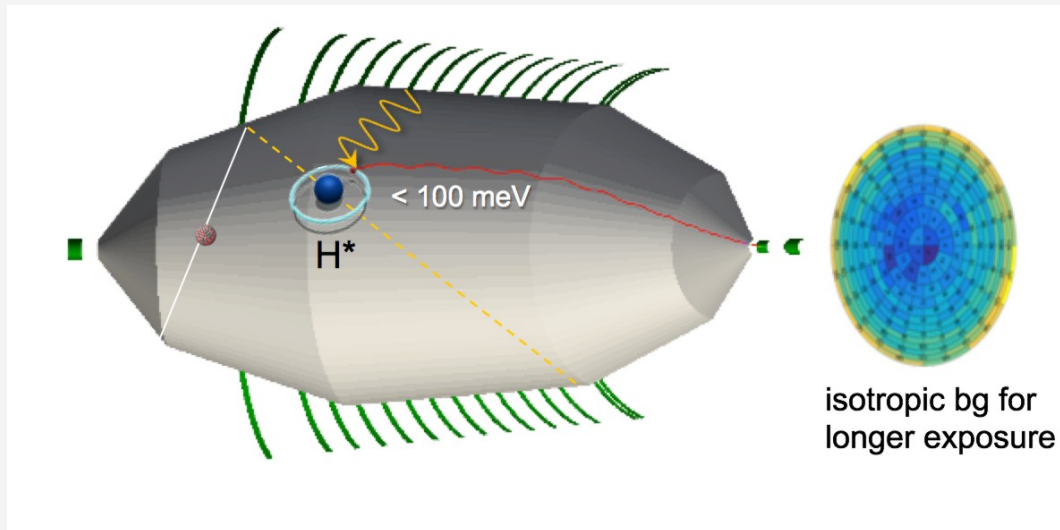

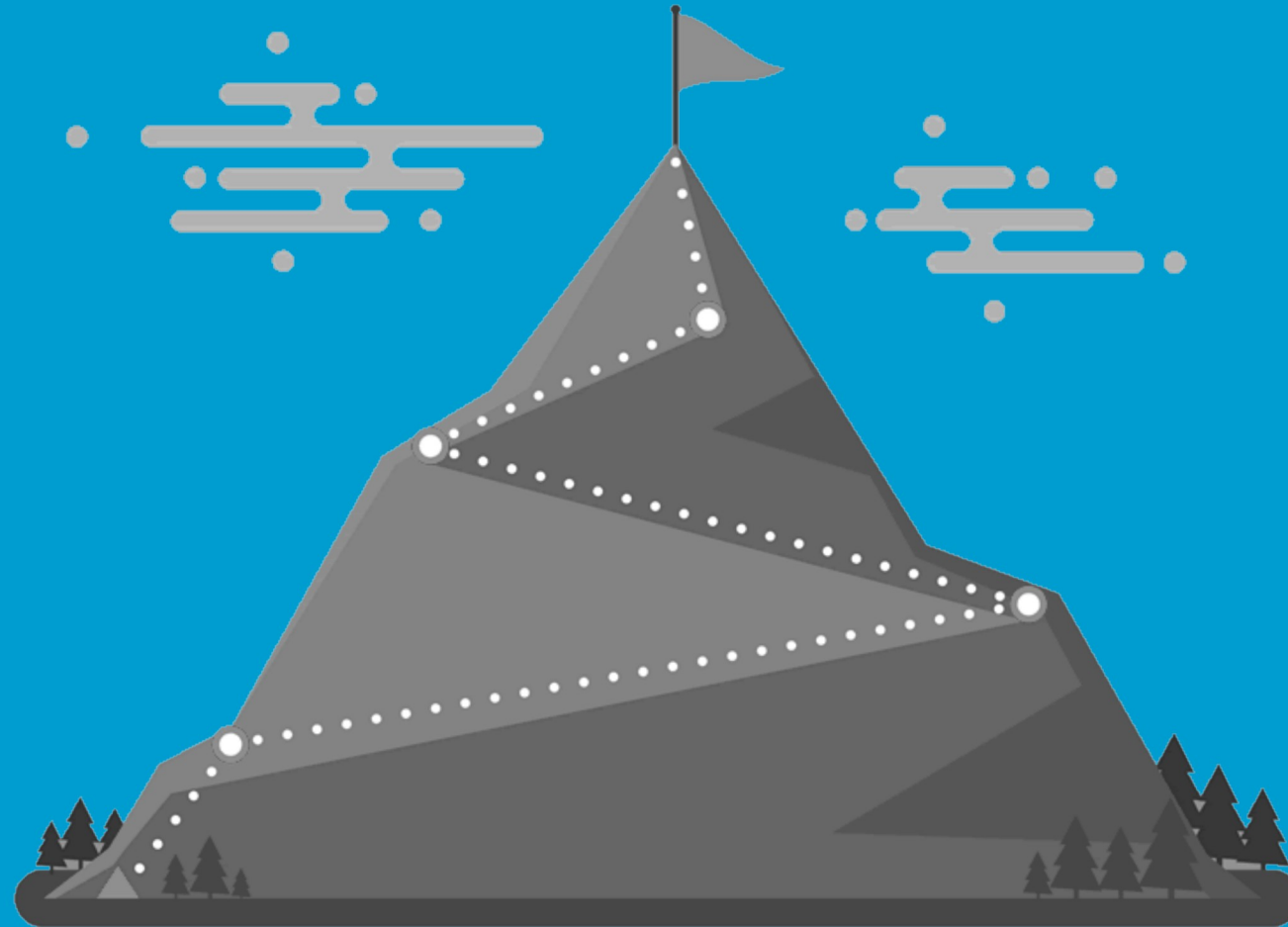

Milestones towards the Neutrino Mass

Technical inauguration of KATRIN – October 2016

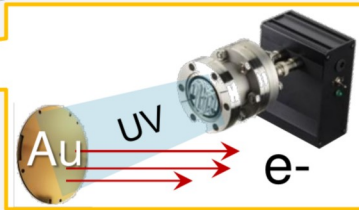
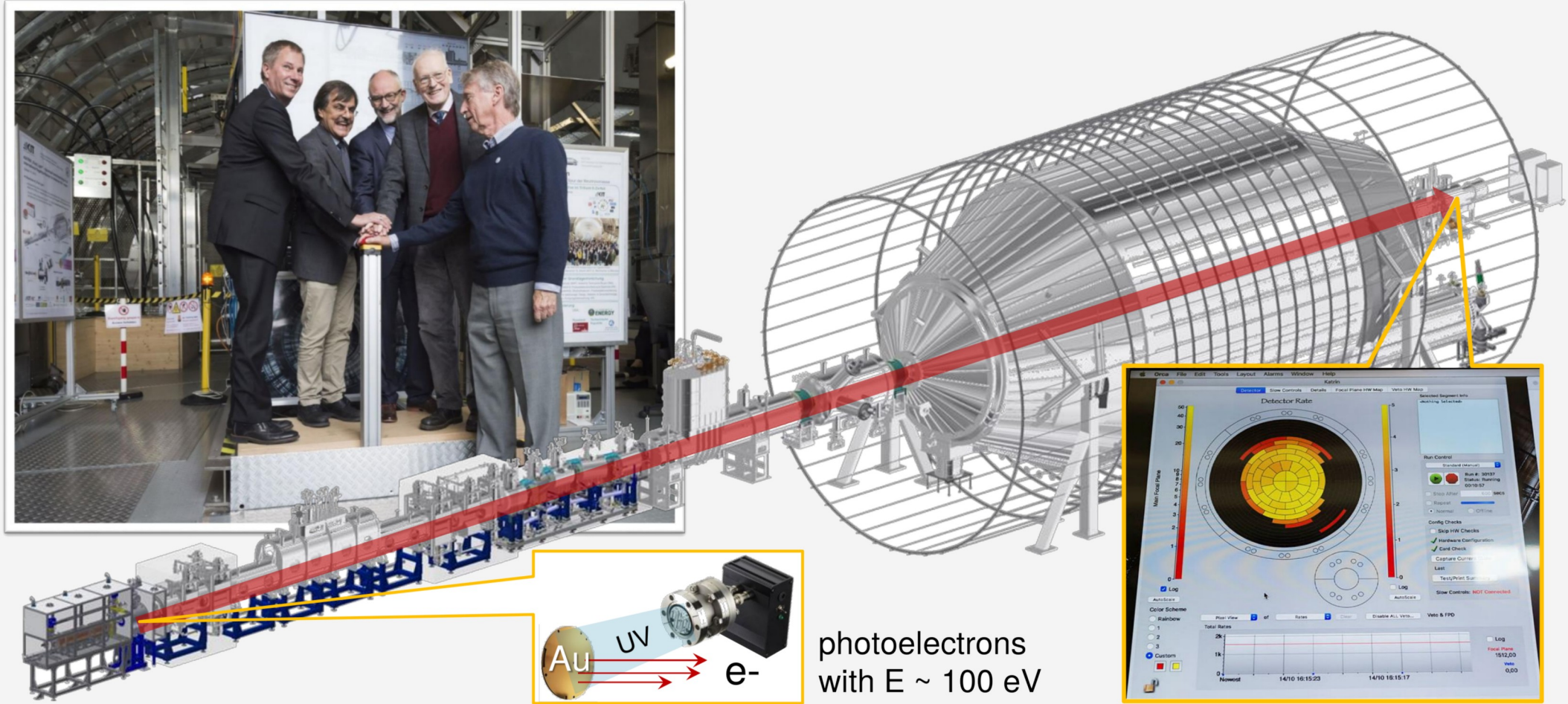

photoelectrons
with $E \sim 100$ eV

KATRIN collab.,
JINST 13 P04020 (2018)

Krypton summer 2017

Use of **monoenergetic conversion electrons from ^{83m}Kr** sources to investigate stability and MAC-E filter spectroscopic properties

gaseous Kr: > 10 m long, full flux tube

condensed Kr: sub-monolayer, spot-like

gaseous Kr-source
in WGTS (T=100 K)

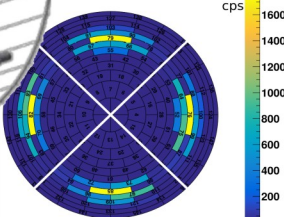
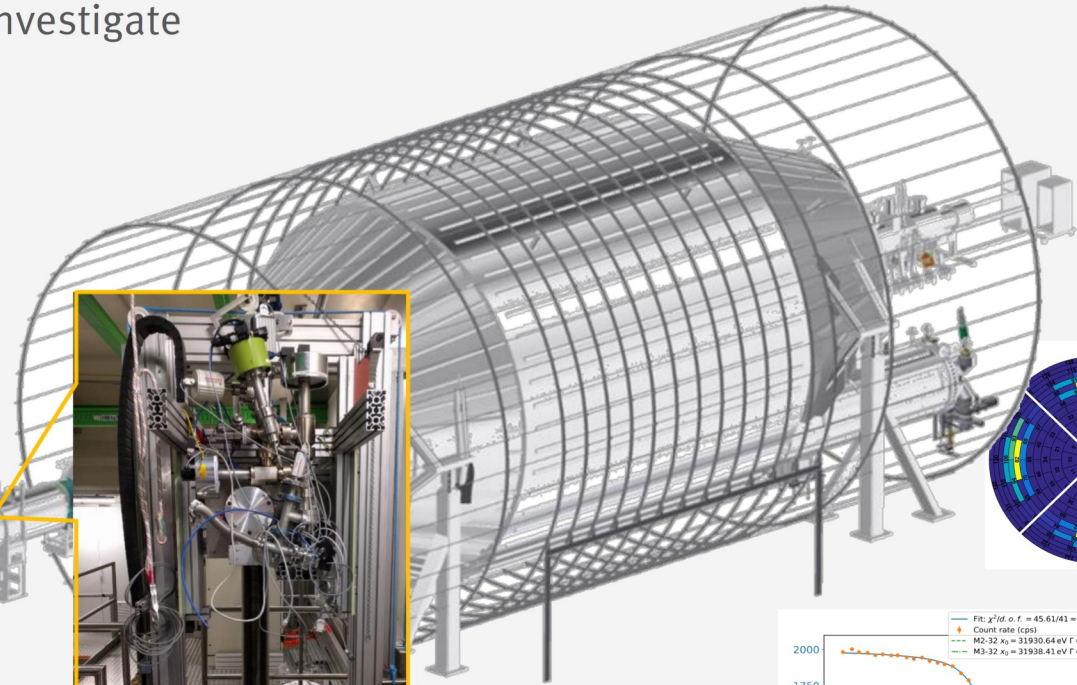
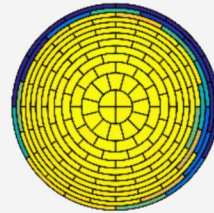

^{83m}Kr from 1 GBq
 ^{83}Rb source

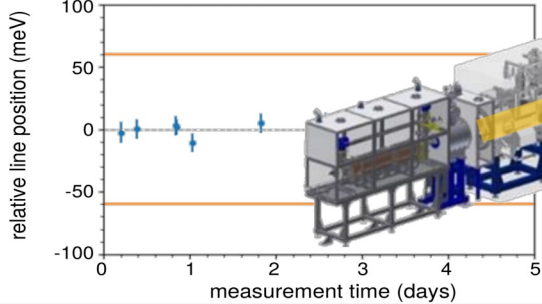

repeated scans of L3-32
line over a week:
required ± 60 meV
GKrS measured

→ excellent long term stability

CKrS line
stability with
pre-plating
 $\approx 1\text{meV/h}$

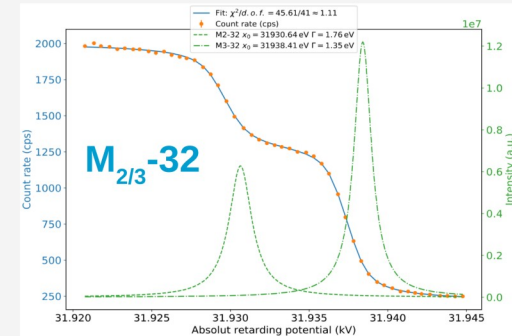

Official inauguration in 2018 – First tritium (engineering run)

method:

- inject known gas mix from prepared cylinders (80% of nominal pd, ~1% DT and ~99% D₂ corresponds to <1% of nominal activity ≈ 500 Mbq)
- verify functionality of all system components and demonstrate 0.1% global stability
- study beta spectrum for systematic effects and test analysis strategies

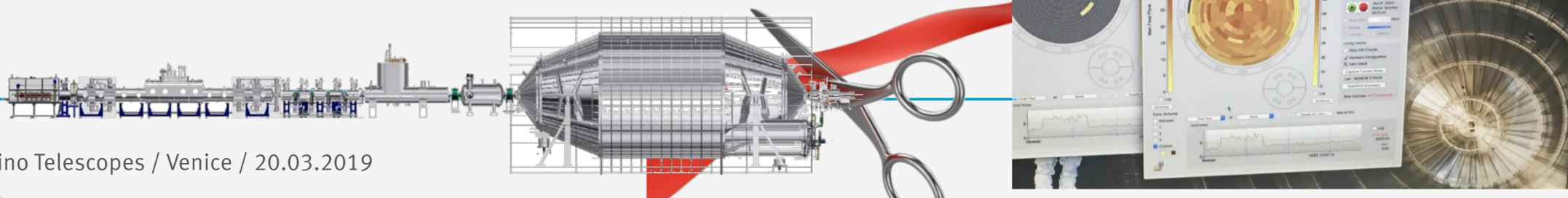



System stability and next steps

Source stability over 12 h

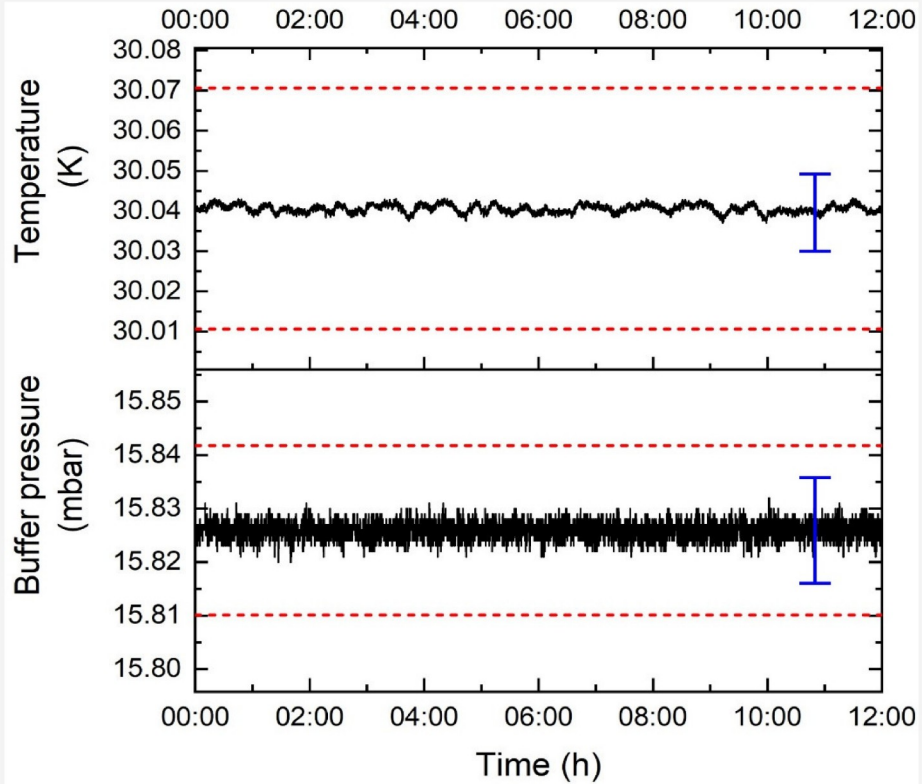

Blue arrow: systematic uncertainty
Red dashed line: $\pm 0.1\%$ stability
required for neutrino mass taking

Source parameters are stable and within the specifications

Schlösser et al.,
J. Mol. Spect. 1044 61 (2013)

System stability

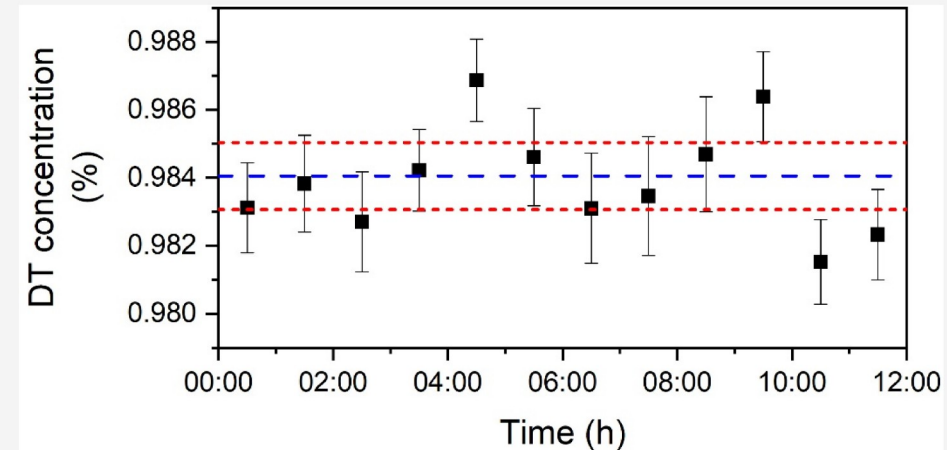
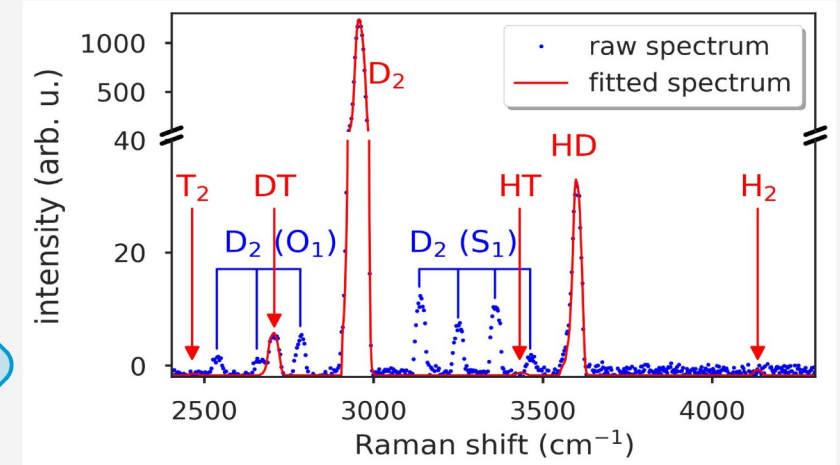

DT concentration measured by
laser Raman spectroscopy

First tritium - Model fits

System stability

Analysis of first tritium scan (200 eV):

model gives very good understanding of both rate and shape (even up to 2 keV!!)

fit (E0, bckg., Amp.) results agree with expectations

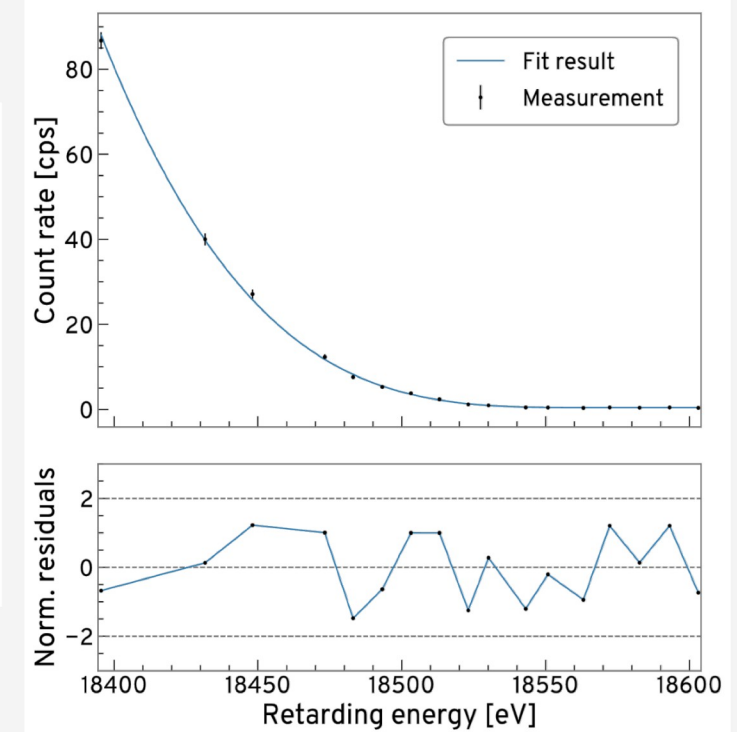
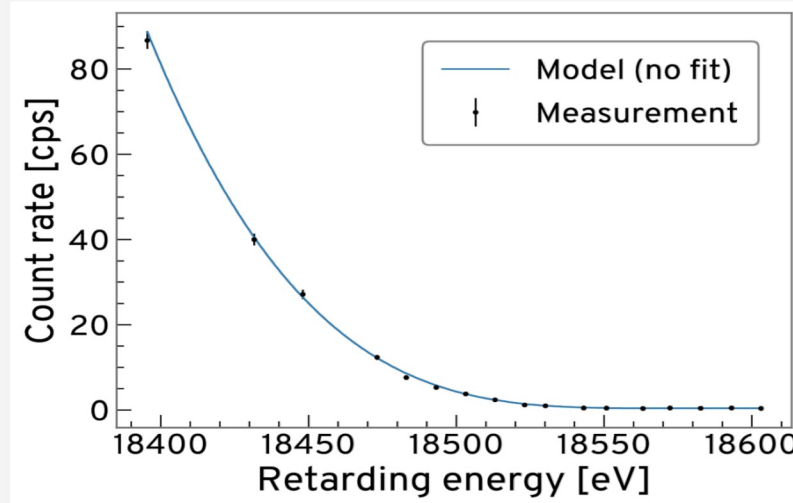

Endpoint stability

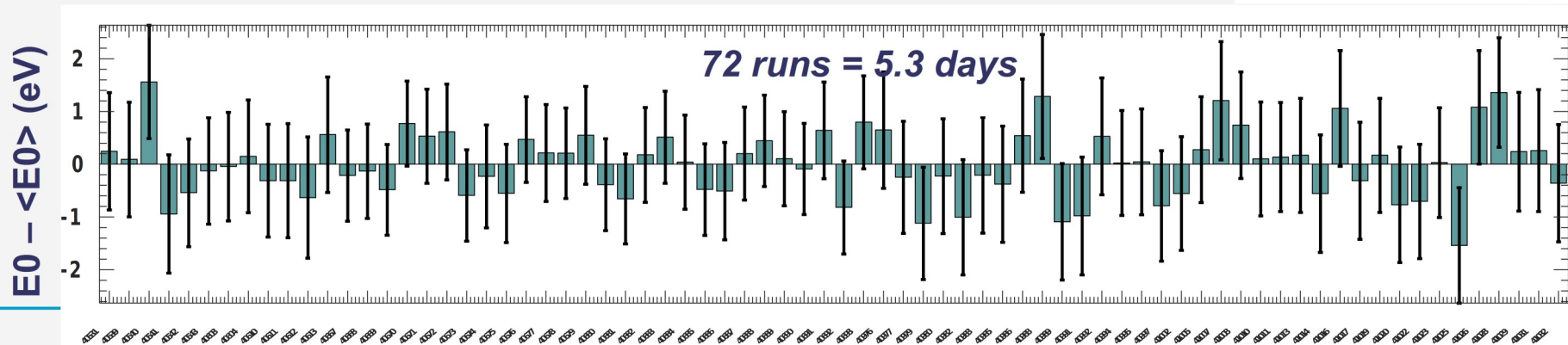

Science Run 0

- Ramping up system to full column density
- First scientific run in March/April 2019
- 30 days of data taking
- Expected mass sensitivity $< 1\text{eV}$

KATRIN started!



KATRIN Spectrometer and Detector Section Status Overview

Page refreshed: Tuesday, 19-Mar-19 09:15:11 CET
Data extracted: Tuesday, 19-Mar-19 09:15:05 CET

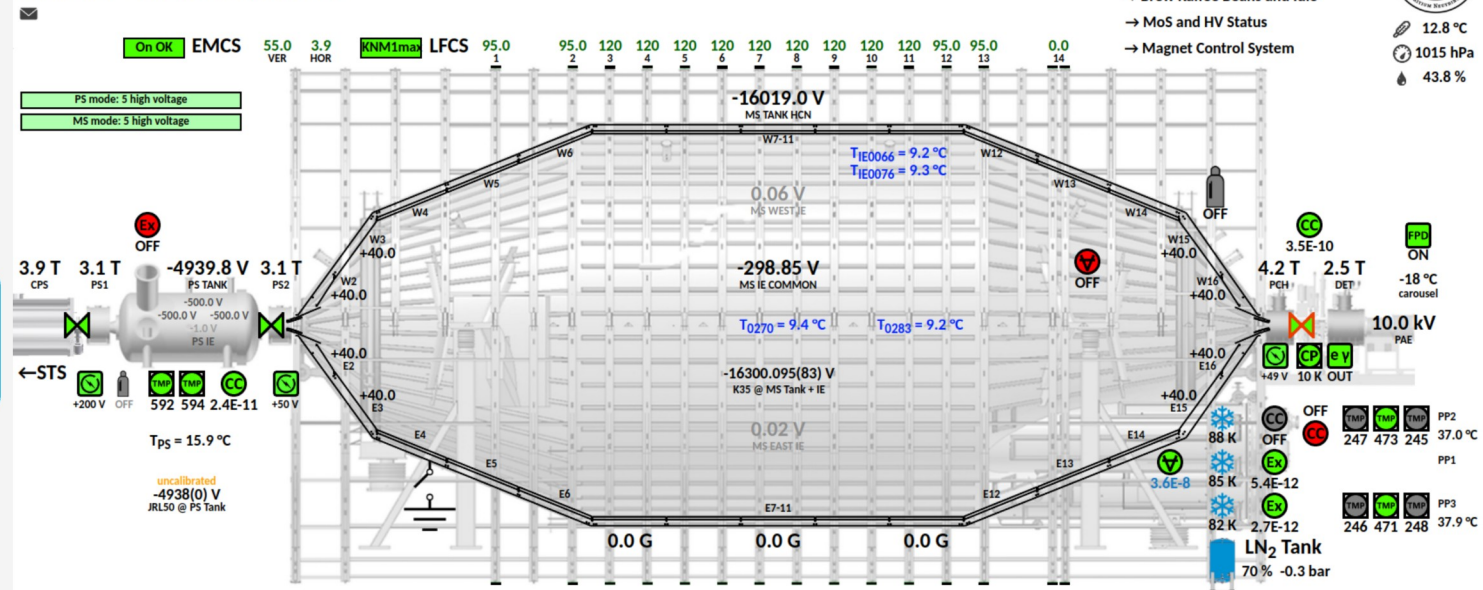

Baffle timestamp: Tue, 19 Mar 2019 09:14:36 +0100
Vacuum timestamp: Thu, 07 Feb 2019 10:32:57 +0100
HV timestamp: Tue, 19 Mar 2019 09:14:51 +0100

Next steps - Sterile Neutrinos

- Extension of KATRIN to search for eV – keV sterile neutrinos
 - Tiny, but characteristic signal further away from the endpoint
- Challenge: ppm sensitivity needed (high statistics, small systematics)
 - New detector system!
- R&D of multi-pixel Silicon Drift Detector (SDD) system ongoing
 - Excellent performance demonstrated with prototype detector system

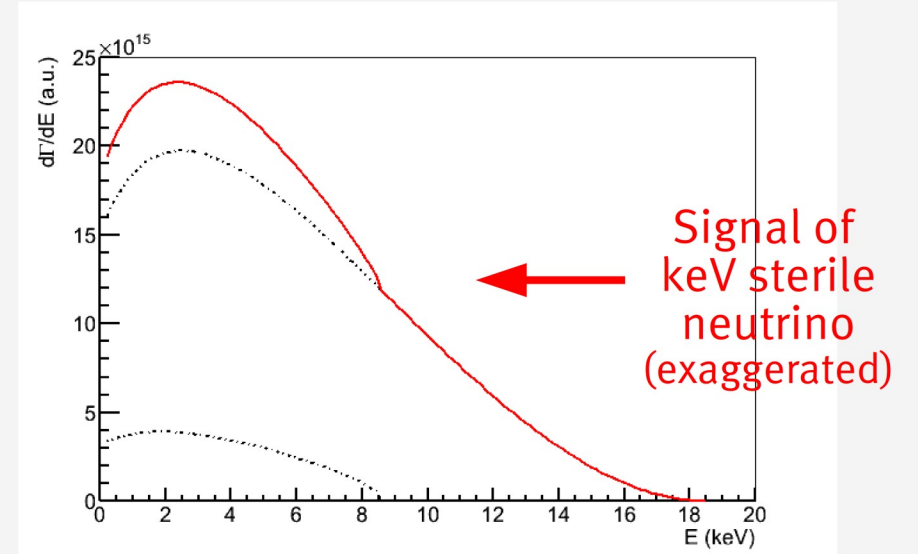

S. Mertens, T. Lasserre *et al.* Phys.Rev. D91 (2015) 4, 042005
 S. Mertens, K. Dolde, M. Korzeczek, *et al.* JCAP 1502 (2015) 02, 020
 K. Dolde, S. Mertens, D. Radford *et al.* NIM-A 848 (2017)
 M. Drewes *et al.*, JCAP 1701 (2017) no.01, 025
 A. Boyarsky, M. Drewes, T. Lasserre, S. Mertens, O. Ruchayskiy,
 arXiv:1807.07938
 S. Mertens, *et al.*: arXiv:1810.06711 [physics.ins-det] (2018)

7 pixel
TRISTAN
prototype

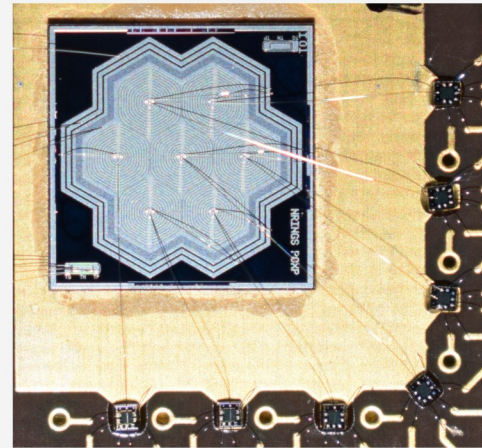

Design of
3500 ch
SDD system

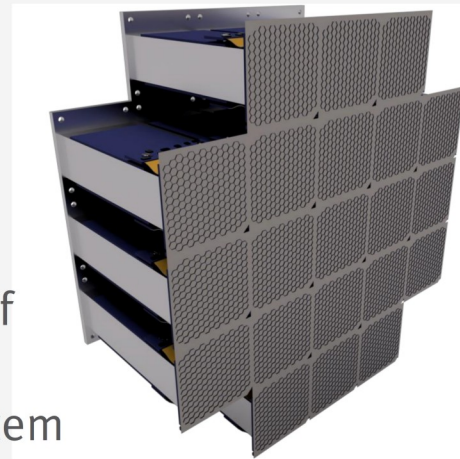

Conclusion and outlook

Neutrino oscillations showed that neutrinos obtain mass but absolute mass scale is unknown

→ Different approaches to measure the absolute mass

KATRIN aims to measure electron anti-neutrino mass with 0.2 eV sensitivity (90% C.L.)

→ Precise measurement of the endpoint region of tritium β decay

KATRIN beamline consisting of a high luminosity windowless gaseous tritium source, transport, spectrometer and detector section

→ System is fully commissioned and in 2018 the official inauguration took place

Currently the KATRIN system gets ramped up

→ Perform the first science run in March/April

Future KATRIN measurement possibilities

→ New detector design for sterile neutrino search

