

# Bandwidth Improvement and Reduced Size MPA Design using HIS

Muhammad Saleem Khan<sup>1</sup>, Irfan Khattak<sup>2</sup>, Muhammad Salman Khan<sup>3</sup>, Asaf Khan<sup>4</sup>

<sup>1,2,3,4</sup>University of Engineering and Technology Peshawar Pakistan

saleemkk51@yahoo.com<sup>1</sup>, m.i.khattak@uetpeshawar.edu.pk<sup>2</sup>, engrcalman.khan@yahoo.com<sup>3</sup>,  
asafkhan@yahoo.com<sup>4</sup>

Received: 09 March, Revised: 22 March, Accepted: 28 March

**Abstract**— Recently, there has been extensive research on high impedance structure (HIS) and their applications in microstrip antennas and transmission lines. These periodic structures have unique property of preventing the propagation of electromagnetic waves for specific frequencies and directions which are defined by the shape, size, symmetry, and material used in their construction. These structures also facilitate in bandwidth enhancement of planar antennas. In this article, a microstrip patch antenna (MPA) is designed to operate at 3.5 GHz. Then a mushroom type HIS ground plane is designed in the operating band of MPA which is further integrated. Aim of this configuration is to enhance bandwidth of the MPA through incorporation of HIS plane, Bandwidth of the MPA is evaluated with and without HIS plane. All the designs and simulations are carried out in CST microwave studio.

**Keywords**— Microstrip patch antenna, high impedance surface, substrate, bandwidth

## I. INTRODUCTION

Multiple elements fashioned from composite materials, like plastic or metals, are assembled and arranged in a repeating patterns result in Metamaterials. Metamaterials do not exist naturally and their electromagnetic properties as well as performance is superior and different from their base materials [1]. This change of properties like permittivity, permeability, refractive index etc. of the host material occurs due to the cutoffs or inclusions of integral elements. Therefore, for achieving a particular electromagnetic performance such materials can be well-thought-out. Metamaterials type Single Negative [2, 3], Double Negative [4, 5] and Electromagnetic Band Gap of planar type structures [6] are in demanding study since 1990s. Sievenpiper [7] introduced mushroom type 2- Dimensional EBG surfaces composed of a regular pattern array of unit cells in a 2 dimensional pattern. The unit cell is sandwiched in between of-patches (conducting) and ground (conducting) with a dielectric substrate. To connect the top metal patches to the ground vias are used to form a mushroom like structure.

For a desired bandwidth, AMC ground plane finds their application and to overpower surface waves propagation. The characteristic properties of AMC ground plane will effect by the dimensions of the EBG unit-cell and substrate thickness. The unit cell is of rectangular or square type. Mushroom,

loop, or spiral may be used as the resonating element. It has been observed that on PEC or conventional EBGs, sense of polarization of incident plane wave reverses resulting in polarization mismatch between-reflected and incident wave. To sidestep this mismatch in several applications [8-11], Polarization dependent EBGs (PDEBGs) are introduced.

In modern wireless communication system, Microstrip patch antenna is considered a smart solution because of their several advantages. It consumes small volume, planarly configurable, mechanically robust and having lightest weight as compared to other antennas. Also its integration is easy with microwave integrated circuits (MICs). Besides various advantages of microstrip patch antennas, main drawbacks are narrow bandwidth, low gain and surface wave excitation. Several techniques can be used to overcome these main issues [12]. First of all, the choice of using a thicker substrate having low dielectric constant is best but the antenna size will increase and thus it will not remain a low-profile. The use of multi resonator stack configuration is another possible solution but again resulting to a large thickness prototype [13, 14]. To minimize the surface waves, electromagnetic band-gap structures are used. The use of EBGs is considered to be a best solution for improving MPA performance among antenna research community [15-17].

Metamaterials like Frequency selective surfaces (FSS) [18-20], which provide either AMC or EBG behavior, is alternative solution to microwave circuits and antenna problems. This option has been used in previous works [20-29].

L probe and U slot have been used by Shakelford et al. [30] in designing a small Microstrip patch antenna. Different designs have been proposed by these authors who utilized various techniques for size reduction: make use of a microwave substrate material, addition of a shorting wall and a shorting pin. A significant improvement in bandwidth is observed in all the designs.

Another method employed by researchers is using compound techniques [31]. These techniques include adjusting the patches displacement, setting two pairs conducting bars loading a capacitive disk on the top of probe and the lower patch as parasitic radiator. A new type of stacked MPA is studied using these compound techniques and the frequency bandwidth has been remarkably improved. In [32], the bandwidth of an aperture coupled MPA has been studied and improved by using an appropriate impedance matching network using filter design techniques. The initial

useful antenna characteristics were maintained for the proposed new feed configuration.

The use of two triangular structures for MPA to improve the bandwidth has also been studied [33] in which two separate triangular patches are used to form patch antenna with a small spacing left between the two triangular patches. A full-wave technique in spatial-domain together with the closed-form Green's function is employed for obtaining the S-parameters of MPA and measurement results confirm a considerable improvement in bandwidth.

In the design of patch antenna, the use of unbalanced structures to improve VSWR characteristic has also been studied previously [34]. Similar to [33], a full wave spatial domain MoM technique together with the closed-form Green functions have been working for characterizing high-frequency S-parameters of Microstrip discontinuities. The obtained results (numerical) are compared with existing measurement data which show a decent agreement to each other. To improve the bandwidth of patch antennas, electromagnetic bandgap (EBG) structures [35] is using different shapes and sizes of EBG. These structures have led to considerable improvement in patch antennas bandwidth. In this article, design of Microstrip antenna along with high impedance structure is demonstrated. Main goal is to improve bandwidth of microstrip patch antenna designed for 3.5 GHz through incorporation of mushroom type high impedance surface (HIS) which is also designed to operate in the same band as that of MPA. The designed HIS ground plane is integrated with MPA and then the integrated design is evaluated for operating band.

Sequence of the paper is as following. Section II mainly deals with theory of MPA and discusses its different pros and cons. Section III deals with design parameters of HIS. Section IV presents design of MPA for 3.5 GHz, design of HIS plane for 3.5 GHz and their integration as well along with discussion of results. At the end conclusion of the research work is presented.

## II. MICROSTRIP PATCH ANTENNA

The basic layered structure with two parallel conductors detached by a thin dielectric substrate is shown in the Figure 1. The upper conductor called patch with a length that is an appreciable fraction of a wavelength ( $\lambda$ ), approximately half a wavelength ( $\lambda/2$ ).

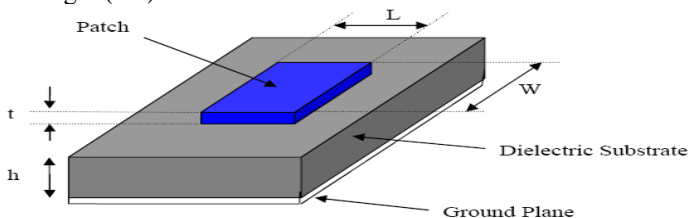

Figure 1. Microstrip patch antenna [36]

The upper conductor patch is generally made of copper and can take any possible shape as shown in Figure 2.

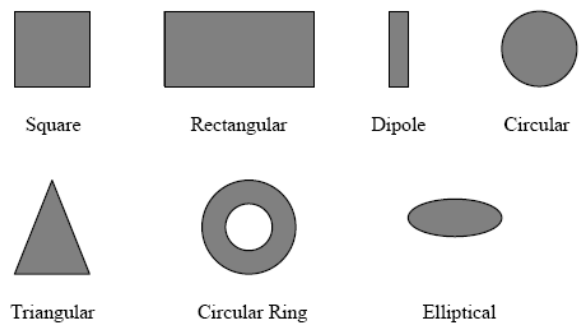

Figure 2. Geometrical shapes and sizes of patch [36]

On the dielectric substrate, the radiating patch and feed lines are usually photo etched. Because of the fringing fields between the ground plane and the patch edge, micro strip patch antennas radiate primarily. Some advantages of MPA discussed by [36] and Kumar and Ray [37] are:

- Low volume and Light weight and lowest fabrication cost.
- Planar configuration and different types polarization support.
- Integration with microwave integrated circuits (MICs) is easy
- Multiple Frequency band operations
- Robust mechanically.

Disadvantages discussed by Kumar and Ray in [37] and Garget al. in [12] are:

- Narrow BW and low efficiency
- Low Gain
- Unnecessary radiation from feeds and junctions
- Power handling capacity is low

The discussion of losses is worth to note here. Different types of losses associated to patch antenna are conduction losses, radiation losses, dielectric and surface wave excitation losses. The quality factor (Q) of Microstrip patch antennas is very high which denote losses of patch antenna. For very thin substrates, all types of losses can be neglected. However, when thickness of the substrate increases, an increasing fraction of the total power delivered by the source goes into a surface wave. This unwanted power loss in surface wave contribution is considered since it is ultimately scattered at the dielectric bends and causes degradation in antenna characteristics.

## III. HIGH IMPEDANCE SURFACE

This article specifically talks about the use of EBG by utilizing its high impedance feature for achieving size reduction in terms of substrate height when incorporated to MPA. Rahmat Samii [38] describes EBG as a periodic or a periodic configuration of multi dimension having power to stop or enhance the transmission of electromagnetic waves in a certain frequency range with no conditional limit of incident angel and polarization. Bandgap is the frequency range in which the surface waves are suppressed. Substrate thickness

and dimensions of the EBG unit-cell affect the band gap characteristic. The unit cell may be either square or rectangular in shape. The mushroom, loop, or spiral may be the resonating element. Rahmat-Samii [39] and Sievenpiper [40] designed several kinds of EBG and HIS configuration

which were further used and find its application in a variety of low profile linear and circularly polarized antennas. HIS design by Sievenpiper is shown below in Figure 3 and 4.

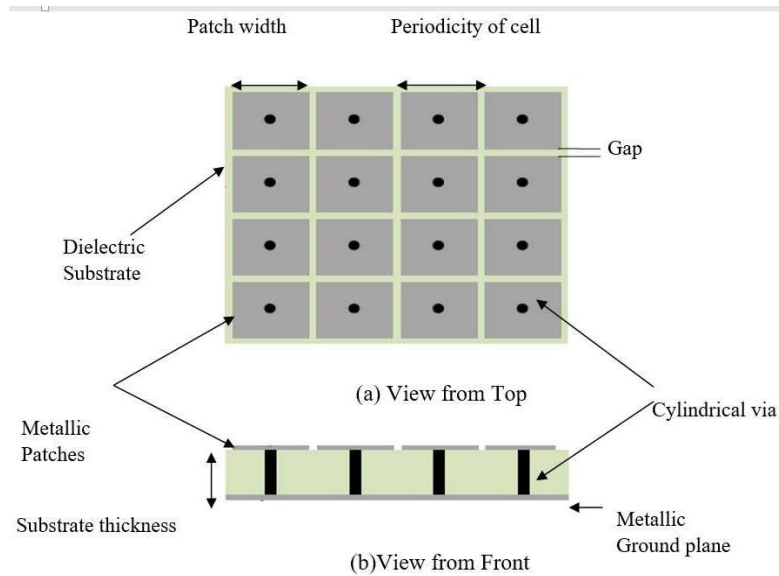

Figure 3. High impedance Surface (Sievenpiper) (a) Top-View (b) Front-View

Planar structures give in-phase reflection and suppress surface propagation in a particular frequency band. Additionally, the antenna currents are in-phase with the image currents, therefore both constructively interfere and provide better antenna performance[41].

$$C = \frac{W(\epsilon_0 + \epsilon_r)}{\pi} \cos$$

Here

- W = Width of the patch
- g = Gap between two adjacent patches
- $\epsilon_r$  = EBG substrate relative permittivity
- h = Thickness of the substrate used
- $\mu$  = Medium permeability

Following equation expressed resonant frequency

From above equation the Frequency Band Gap (BW) can be come near to as

$$E$$

Here  $\eta$  is the intrinsic impedance of free-space =  $120\pi$

By suppressing surface waves, these assemblies are very co-operative just in case of planer antennas resulting in directivity, efficiency of the antenna and achieving high gain [42-43]. EBGs can also be utilized for GPS applications [44-45]. It has been observed that when EM wave in plane orientation incident on Perfect Electric Conductor or planner EBGs, sense of polarization reverses resulting in mismatching in polarization. In order to side-step this kind of mismatch,

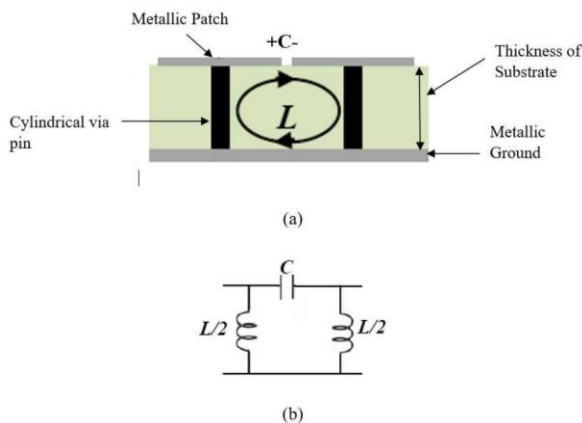

Figure 4. Equivalent circuit (LC) model (a) Front-View (b) Equivalent resonant circuit (LC)

To explain operation of HIS, consider Figure 4. It can be seen that HIS behavior is just parallel resonant circuit. The charge distribution among neighboring cells correspondent to capacitance C while the current flow through metallic via from top and bottom results to inductance L. Following formula determines L and C values [39].

PDEBGs (Polarization dependent EBGs) in several applications are introduced [46-47].

#### IV. RESULTS AND DISCUSSIONS

Planar antennas are normally desired in most of wireless communication systems. MPA is one of widely used planar antenna which is desired in several applications. In this research we will mainly focus on MPA design which will further be evaluated for bandwidth enhancement through incorporation of HIS.

Here MPA is designed for 3.5GHz having structural configurations and dimensions as depicted in Figure 5.

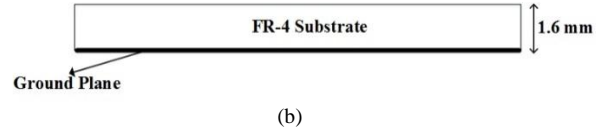
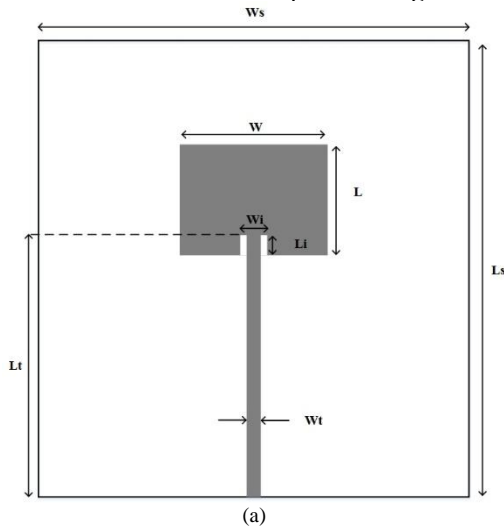

Figure 5. Illustration of geometry for Microstrip Patch antenna (a) Top View (b) Side View

TABLE I: DIMENSIONS FOR MPA

Dimension	Value (mm)
$W_s$	130
$L_s$	130
$W$	20
$L$	18
$W_t$	2.5
$L_t$	60
$W_i$	7
$L_i$	5.5

Here FR4 material is used for substrate of the antenna.  $W_s$  and  $L_s$  are width and length of the substrate material. Similarly patch element of the antenna has length  $L$  and width  $W$ . microstrip line having 50-ohm impedance is used to excite the antenna that has length  $L_t$  and width  $W_t$ . For matching purpose an inset cut of  $L_i \times W_i$  is made in patch of the antenna. This modeling and designing is performed in CST microwave studio. Operating band of the antenna is given in Figure 6.

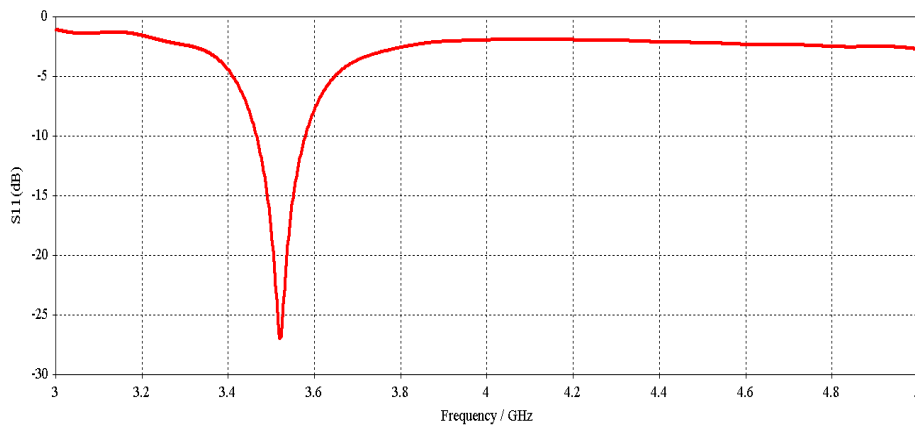
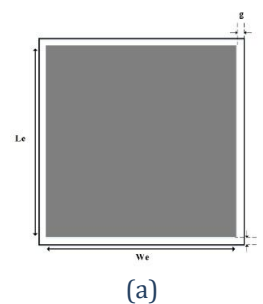
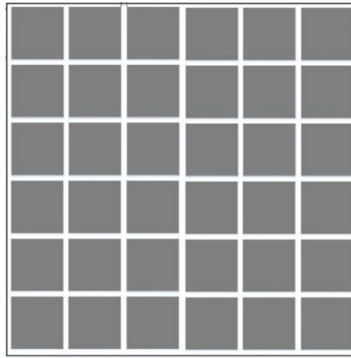

Figure 6. MPA response designed for 3.5 GHz

Here we can see that MPA is resonating at 3.5 GHz having -27 dB return loss value. Bandwidth of the antenna is 116 MHz ranging from 3.463 GHz to 3.5803 GHz.

Next step is design of high impedance surface in the operating band of MPA. For this purpose mushroom type high impedance surface is modeled and designed in CST microwave studio. Here a via less design is utilized for the sake of simplicity. Unit cell along with in-phase reflection response of the HIS plane is given in Figure 7





(b)

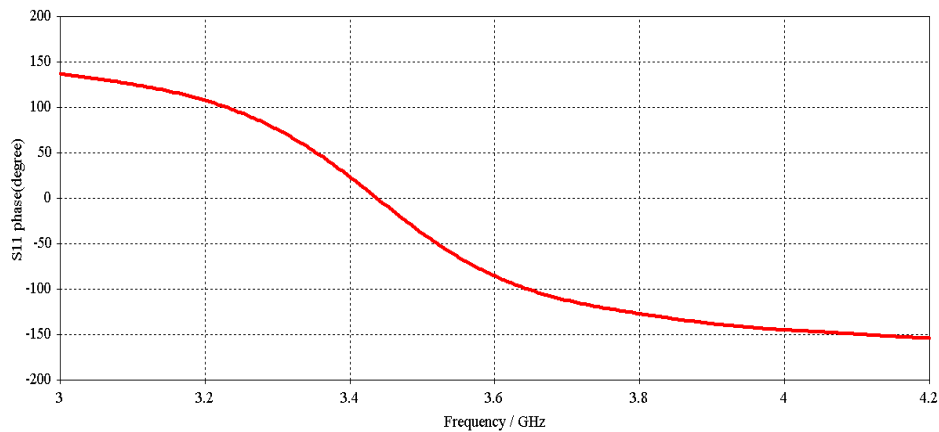

(c)

Figure 7. HIS Ground plane with results (a) Unit Cell (b) Configuration of 6x6 patch HIS ground plane (c) In-phase reflection response of HIS plane

Dimension of unit cell is 18 mm x 18 mm having a gap of 0.125 mm which is utilized to form a 6 x 6 patches of HIS ground plane. Reflection phase response as depicted in Figure 7 show that in-phase reflection occurs near 3.45 GHz.

wide band frequency response was observed as can be seen in Figure 8.

After design of HIS plane, the MPA was integrated to it. For this purpose, ground plane of MPA was removed and replaced with the HIS ground plane thus forming the integrated antenna. Upon exciting the integrated antenna, a

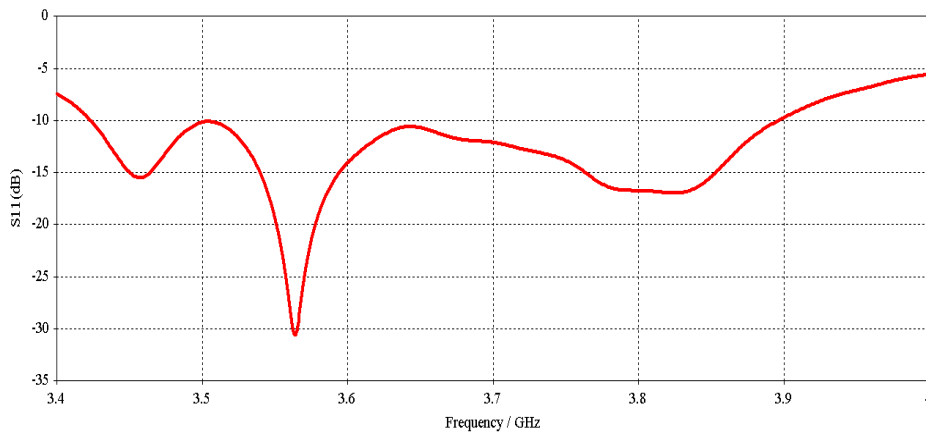

Figure 8. Operating band of integrated antenna

As can be seen that integrated antenna for 3.5 GHz has operating bandwidth of 485MHz ranging from 3.4221GHz to 3.9077GHz. Hence 318.1 % increase in operating bandwidth is observed as compare to bandwidth of MPA which is only 116MHz before integration.

#### CONCUSLION

This article discusses microstrip patch antenna design issue and its resolution through incorporation if high impedance structure. The aim is to counter narrow bandwidth, being a critical design constraint of MPA, through integration of HIS ground plane to the antenna. For this purpose, MPA is initially designed to operate at 3.5 GHz. The antenna is resonating at 3.5 GHz with a return loss value of -27 dB and a bandwidth of 116 MHz ranging from 3.463 GHz to 3.5803 GHz is observed. Afterwards, HIS ground plane was designed in the operating band of MPA which shows in-phase reflection at 3.45 GHz. This HIS was utilized as ground plane of MPA to form the integrated design. It has been observed that integrated antenna was also resonating at 3.5 GHz with a bandwidth of 485 MHz ranging from 3.4221GHz to 3.9077GHz. Hence 318.1 % increase in operating bandwidth is observed as compare to bandwidth of MPA which is only 116MHz before integration.

#### REFERENCES

- [1] A. Pirhadi, F. Keshmiri, M.Hakkak, and M. Tayarani, "Analysis and design of dual band high directivity EBG resonator antenna using square loop FSS AS superstrate layer," *Progress in Electromagnetics Research*, vol. 70, pp. 1–20, 2007.
- [2] A. Sihvola, "Electromagnetic emergence in metamaterials", *Advances in Electromagnetics of Complex Media and Metamaterials*, vol. 89, pp. 1–17, 2003.
- [3] J. Zehentner and J. Machac, "Volumetric single negative metamaterials", *Proceedings of Metamaterials Congress*, pp. 22–24, 2007
- [4] N. Engheta, "Metamaterials with negative permittivity and permeability: background, salient features, and new trends", *IEEE MTT-S International Microwave Symposium Digest*, pp. 187-190, 2003.
- [5] N. Engheta, "Design, fabrication, and testing of double negative metamaterials", *IEEE Transactions on Antennas and Propagation*, vol. 51, issue. 7, pp. 1516-1529, 2003
- [6] W. R. Ziolkowski and N. Engheta, "Metamaterials: Physics and Engineering Explorations", *John Wiley & Sons, Inc.*, 18 September 2006.
- [7] D. Sievenpiper, "High Impedance Electromagnetic Surfaces", Ph.D. dissertation, Electrical Engineering Department, University of California, Los Angeles, 1999.
- [8] P. Kovács, Z. Raida, M. Martínez-Vázquez, "Parametric study of mushroom-like and planar periodic Structures in terms of simultaneous AMC and EBG Properties", *Radio Engineering*, vol. 17, no. 4, pp. 19-24, December 2008.
- [9] S. K. Hampel, O. Schmitz, O. Klemp, and H. Eul, "Design of Sievenpiper HIS for use in planar broadband antennas by means of effective medium theory", *Adv. Radio Sci.*, pp. 87-94, 2007.
- [10] F. Yang and Y. Rahmat-samii, "Reflection phase characterisation of EBG ground plane for low profile wire antenna applications", *IEEE Transactions on Antennas and Propagation*, vol. 51, no. 10, October 2003
- [11] D. F. Sievenpiper, J. H. Schaffner, H. J. Song, R. Y. Loo, "Two-dimensional beam steering using an electrically tunable impedance surface", *IEEE Transactions on Antennas and Propagation*, vol. 51, no. 10, pp. 2713-2722, October 2003.
- [12] G. Poilasne, "Antennas on High impedance ground planes: on the importance of the antenna isolation," *Progress in Electromagnetics Research*, vol. 41, pp. 237–255, 2003.
- [13] S. Zhu and R. Langley, "Dual-band wearable textile antenna on an EBG substrate," *IEEE Transactions on Antennas and Propagation*, vol. 57, no. 4, pp. 926–935, 2009.
- [14] M. Mantash, A. C. Tarot, S. Collardey, and K. Mahdjoubi, "Dual-band antenna for WLAN application with EBG," in the 4th International Congress on Advanced Electromagnetic Materials in Microwaves and Optics, pp. 794–796, Karlsruhe, Germany, September 2010.
- [15] M. Mantash, A. C. Tarot, S. Collardey, and K. Mahdjoubi, "Dual-band CPW-fed G-antenna using an EBG structure," in *Antennas and Propagation Conference (LAPC)*, pp. 453–456, Loughborough, UK, 2010.
- [16] Shakelford, A., Lee, K.F., Luk, K.M., "Design of small-size wide-bandwidth microstrip patch antennas," *Antennas and Propagation Magazine, IEEE*, vol. 45, Issue 1, pp. 75-83, Feb. 2003.
- [17] Ting-Hua Liu and Wen Xun Zhang, "Compound techniques for broadening the bandwidth of microstrip patch antenna," *Microwave Conference Proceedings*, vol. 1, pp. 241-244, Dec. 1997.
- [18] Adilena Slavova, A. Abdel Rahman and A.S. Omar, "Broadband bandwidth enhancement of an Aperture coupled microstrip patch antenna," *Antennas and Propagation Society International Symposium*, vol. 4, pp. 3737-3740, June 2004.
- [19] Tao Yuan, Jian-Ying Li, Le-Wei Li, Lei Zhang, and Mook-Seng Leong, "Improvement of Microstrip Antenna Performance Using Two Triangular Structures", *Digest of 2005 IEEE Antennas and Propagation Society International Symposium*, vol. 1A, pp. 301-304, 3-8 July 2005.
- [20] J.Y. Li, Zaw-ZawOo, and Le-Wei Li, "Improvement of characteristics of microstrip antennas using unbalanced structures," *IEEE Antennas and wireless Propagat. Lett.*, vol. 1, pp. 71-73, 2002
- [21] E. Yablonvitch, "Photonic band-gap structures," *J. Opt. Soc. Amer. B, Opt. Phys.*, vol. 10, no. 2, pp. 283-295, Feb 1993.
- [22] Balanis, C.A., *Antenna Theory: Analysis and Design*, John Wiley & Sons, Inc, 1997.
- [23] Kumar, G. and Ray, K.P., *Broadband Microstrip Antennas*, Artech House, Inc, 2003.
- [24] Cisco, "Antenna Pattern and Their Meaning," Copyright © 1992–2007 Cisco Systems, Inc.
- [25] B. Jecko, T. Monediere, L. Leger, "High Gain EBG Resonator Antenna", 18th International Conference on Applied Electromagnetics and Communications, ICECom 2005, pp. 1-3, 12-14 Oct. 2005 [2] R. Garg, I. Bhartia, I. Bahl, and A. Ittipiboon, *Microstrip Antenna Design Handbook*, Artech House, Boston, Mass, USA, 2001.
- [26] G. Kumar and K. C. Gupta, "Directly coupled multiple resonator wide-band microstrip antenna," *IEEE Transactions on Antennas and Propagation*, vol. 33, no. 6, pp. 588–593, 1985.
- [27] F. Yang, X. X. Zhang, X. Ye, and Y. Rahmat-Samii, "Wide-band E-shaped patch antennas for wireless communications," *IEEE Transactions on Antennas and Propagation*, vol. 49, no. 7, pp. 1094–1100, 2001.
- [28] E. Rajo-Iglesias, L. Incl'an-S'anchez, and O. Quevedo-Teruel, "Back radiation reduction in patch antennas using planar soft surfaces," *Progress In Electromagnetics Research Letters*, vol. 6, pp. 123–130, 2009.
- [29] Z. Duan, S. Qu, and Y. Hou, "Electrically small antenna inspired by spired split ring resonator," *Progress In Electromagnetics Research Letters*, vol. 7, pp. 47–57, 2009.
- [30] F. Yang and Y. Rahmat-Samii, "Electromagnetic Band-Gap Structures in Antenna Engineering", *The Cambridge RF and Microwave Engineering Series*, Cambridge University Press, Cambridge, Mass, USA, 2008.
- [31] M. E. De Cos, F. L. Heras, and M. Franco, "Design of planar artificial magnetic conductor ground plane using frequency selective surfaces for frequencies below 1GHz," *IEEE Antennas and Wireless Propagation Letters*, vol. 8, pp. 951–954, 2009.

- [32] O. Luukkonen, C. R. Simovski, and S. A. Tretyakov, "Grounded uniaxial material slabs as magnetic conductors," *Progress in Electromagnetics Research B*, no. 15, pp. 267–283, 2009.
- [33] H. Shaban, H. Elmikaty, and A. A. Shaalan, "Study the effects of electromagnetic band-gap (EBG) substrate on two patch microstrip antenna," *Progress in Electromagnetics Research B*, vol. 10, pp. 55–74, 2008.
- [34] F. Yang and Y. Rahmat-Samii, "Reflection phase characterizations of the EBG ground plane for low profile wire antenna," *IEEE Transactions on Antennas and Propagation*, vol. 51, no. 10, pp. 2691–2703, 2003.
- [35] J. R. Sohn, K. Y. Kim, H. S. Tae, and J. H. Lee, "Comparative study on various artificial magnetic conductors for low-profile antenna," *Progress in Electromagnetics Research*, vol. 61, pp. 27–37, 2006.
- [36] S. Chaimool, K. L. Chung, and P. Akkaraekthalin, "Bandwidth and gain enhancement of microstrip patch antennas using reflective metasurface," *IEICE Transactions on Communications*, vol. E93-B, no. 10, pp. 2496–2503, 2010.
- [37] J. Liang and H. Y. D. Yang, "Radiation characteristics of a microstrip patch over an electromagnetic bandgap surface," *IEEE Transactions on Antennas and Propagation*, vol. 55, no. 6, pp. 1691–1697, 2007.
- [38] D. Sievenpiper, L. Zhang and E. Yablonovitch, "High-Impedance Electromagnetic Ground Planes", *IEEE MIT-S Digest*, vol. 4, pp. 1529-1532, 1999.
- [39] Qian Y., Coccioli R., Sievenpiper D., Radisic V., Yablonovitch E., and Itoh T., "A Microstrip Patch Antenna using novel photonic bandgap structures", *Microwave J.*, vol 42, pp. 66-76, Jan 1999.
- [40] Z. Duan, D. Linton, W. Scanlon, and G. Conway, "Using EBG to Improve Antenna Efficiency in Proximity to the Human Body", *Institution of Engineering and Technology Seminar on Wideband, Multiband Antennas and Arrays for Defence or Civil Applications*, pp. 173-180, London, 13-13 March 2008.
- [41] X. L. Bao, G. Ruvio, M. J. Ammann, and M. John, "A novel GPS patch antenna on fractal Hi-Impedance surface Substrate", *IEEE Antenna and Wireless Propagation Letters*, vol. 5, 2006.
- [42] R. Baggen, M. Martínez-Vázquez and J. Leiss, "Low Profile GALILEO Antenna using EBG Technology", *IEEE Transactions on Antennas and Propagation*, vol. 56, no. 3, pp. 667-674, March 2008.
- [43] F. Yang, Y. Rahmat-Samii, "Polarization-Dependent Electromagnetic Band Gap (PDEBG) structures: designs and applications", *Microwave and Optical Technology Letters*, vol. 41, issue. 6, pp. 439–444, June 20, 2004.
- [44] Y. Fu and N. Yuan, "Surface-wave bandgap of Polarisation dependent Electromagnetic bandgap Structures", *Microwave and Optical Technology Letters*, vol. 49, issue 4, pp. 946–949, 26 February 2007.
- [45] D. Yan, Q. Gao, C. Wang, C. Zhu, N. Yuan, "A novel polarisation convert surface based on artificial magnetic conductor", *Asia-Pacific Microwave Conference Proceedings, APMC 2005*, vol. 3, pp. 4-7, December 2005.
- [46] P. J. Ferrer, B. Kelem and C. Craeye, "Design of broadband transpolarizing surfaces", *Microwave and Optical Technology Letters*, vol. 48, no. 12, pp. 2606-2611, December 2006.