

Optimised Control of 10 MW Photovoltaic (PV) Plant with 1MW / 1MWh Battery

Per Nørgaard, Henrik Bindner, Anders Thavlov
Center for Electric Power and Energy
Technical University of Denmark
Roskilde, Denmark

Michalis Florides, Venizelos Venizelou, Minas Patsalides, Charalambos Anastassiou, George Makrides, Venizelos Efthymiou, George E. Georghiou
PV Technology Laboratory, FOSS Research Centre for Sustainable Energy
University of Cyprus
Panepistimiou 1 Avenue, Nicosia, Cyprus

Abstract - With the existing energy systems and electricity grids worldwide being developed as smart systems and grids with increased renewable energy in general, there are critical needs in smart grid knowledge, development, testing, demonstration, evaluation, education and training. The University of Cyprus (UCY) is presently establishing a complete new green-field campus in Nicosia and is looking at the opportunity to introduce smart, sustainable and cost and energy efficient solutions for the energy services at the campus as a truly smart grid living lab. As part of this vision, UCY plans to install 10MWp PV capacity and 1MW/1MWh battery storage at the campus. This paper presents the specific context of the power system in Cyprus and the future UCY microgrid along with the possible and expected impacts of the PV plant and Battery Energy Storage System. The battery control strategies are tested at the experimental facility SYSLAB at The Technical University of Denmark (DTU).

Keywords-component: microgrid, PV, battery, energy management

I. INTRODUCTION

The recent years have witnessed a profound reassessment of the electric power infrastructure, and the series of radical initiatives that have been planned to revitalise the grid have been grouped under the evocative term of a microgrid (μ G) programme. A μ G accommodates not only large, centralised power plants, but also the growing array of customer-sited distributed energy resources.

The University of Cyprus (UCY) has the aspiration to become an institution that fosters and disseminates environmental awareness and sustainable development in the local community by achieving a balance between economic, social and environmental parameters. The University plans to install a 10MW solar power plant and a 1MW/1MWh battery at the university campus as part of sustainable energy solutions for the campus, also functioning as a smart energy living lab for research, education and innovation.

Introducing such a large scale solar power in the system represents a challenge for the operation of the integrated system. The Distribution System Operator (DSO) has therefore specified requirements for the operation of the 10MW solar power plant. In order to investigate the integration of the PV plant and the battery energy storage system (BESS) into the University a simulation was performed to determine the optimum control algorithm parameters [1]. More specifically, the objective was to study the impact on busbar voltage of the μ G system at the point of common coupling (PCC) under a certain control algorithm [2] which aims to minimize the electricity bill cost.

Testing experimental controllers on a real-world grid is difficult and often not very practical at the same time, because the cost of an accidental disturbance would be prohibitive [3]. A small experimental grid can be a useful compromise, where many fundamental principles of power system operation can be applied and tested, while the consequences of failure are minimal. Results obtained on such a μ G can aid the development of a larger real life μ G. Therefore, a small experimental grid like the experimental facility SYSLAB, located at Technical University of Denmark (DTU), can be useful for this kind of research purposes.

For this experiment, the PV capacity and BESS size will not be the actual ones that will be installed at the UCY campus. They are just a first approximation of what it is planned to be installed in order to demonstrate the effects of such a large scale system on voltage levels at the PCC.

In what follows, the description of the future μ G at UCY campus and the SYSLAB experimental facility are presented. Then, the modelling of the μ G is explained along with the methodology used in the experiment. Finally, the results and conclusions are presented.

II. THE UCY CAMPUS MICROGRID

For the time being, UCY has a peak load of 2.4MWp and a local PV generation of 400kWp connected and operated as self-consumption. However, the load demand

is expected to almost double by 2017 due to the planned campus expansion. In addition to the construction of the new buildings, several other utility scale projects have been rationally developed to contribute to the aim of the University to minimize its energy footprint.

One of the major projects that are being planned to help achieve the ambitious goal of the University to eventually become a carbon neutral institution is a PV plant with a capacity of 10MWp. The plant aims to generate the electricity necessary to totally offset the energy consumption of the whole campus making it a net-zero energy campus. The plant is envisioned to also include an electric storage facility of 1MW/1MWh capacity (estimated but not optimised yet). Both projects are expected to be fully operational by the end of 2017. Furthermore, UCY will utilize a full broad-band connectivity with the local DSO using fiber optic cables and power line communication (PLC) infrastructure allowing bi-directional flow of data at the PCC along with smart meter facilities capable of offering valuable data and local control for the development of an effective demand side management (DSM) policy for the whole UCY Campus.

The application of all these different technologies within a concentrated area provides unique research opportunities to further study and investigate the integration of these into the energy mix of a small community such as the University Campus. It is easily realized that a lot of optimization questions arise when different technologies are present in terms of the operating conditions that provide the best energy and economic operation management [4]. Fig.2 illustrates the future UCY μ G.

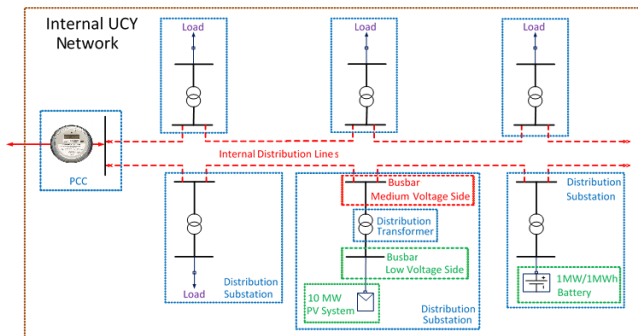

Figure 1. The envisaged UCY μ G connection diagram.

III. SYSLAB EXPERIMENTAL FACILITY

SYSLAB is a laboratory for research within a broad range of topics in distributed power systems, such as control in power systems with a high penetration from renewable energy, communication and interoperability, as well as software engineering and cyber security. The facility is located at the DTU Risø Campus near Roskilde, Denmark, and consists of many diverse distributed energy resources (DER), i.e. with generation, consumption and storage capabilities.

Each site features a local substation switchboard with 400V three-phase AC busbars, one of which can be connected to the public grid [5]. A central crossbar switchboard allows automated topology changes during operation. At present the DERs comprise of 25kW

distributed photovoltaics (3 sites), 20kW distributed wind turbines (2 sites), a 50kW diesel power plant, 75kW dumb load/load bank, three 35kW mobile dumb loads, a 15kW/120kWh vanadium redox battery (VRB), a 45kVA back-to-back converter, three intelligent buildings (2 residential and 1 office) and several electric vehicles (EV), some of which have vehicle-to-grid (V2G) capabilities. [3]

Grid circuit breakers allow the laboratory grid to be isolated, and thus experiments can be run in island mode. The laboratory facilities are located at four main sites, which can be connected via a centralized cross-busbar. This leads to a very flexible configuration, which allows the laboratory DERs to be connected in virtually any configuration.

A dedicated node corresponds to each DER node. The node is a self-contained unit, which maintains low-level control of the DER, local data logging and provides a software interface to the SYSLAB computer network, which allows interaction with the rest of the system. Interacting with the node, using the software interface, requires a Matlab interface which allows researchers to interact with the system. In this way, the laboratory gives access to a broader range of researchers, with little or no experience in software development. This enables researchers to shift away from pure simulations to testing their control algorithms in a laboratory, by including hardware in simulations, i.e. with hardware in the loop. Trialing algorithms in a live laboratory environment allows real problems (such as external disturbances and delay in communication, etc.) which are hard to emulate in a pure simulation environment to be considered.

IV. POWER SYSTEM MODELLING

The expected impact of the PV plant and value of the control algorithm of the battery was experimentally tested by setting up an experiment at the facilities of SYSLAB at DTU.

The experimental setup included the following SYSLAB components:

- 1) 20kWp PV;
- 2) 15kW/120kWh VRB battery plus controller;
- 3) A 35kW controllable resistive load that emulates the UCY load pattern;
- 4) A connection to the grid rated at 200 kVA.

The above setup was used to replicate a down-scaled μ G of the future UCY μ G. The available PV capacity at DTU was 20kWp and the planned PV capacity for UCY is 10MWp which results in a ratio of 1:500. This ratio was used for sizing the battery (power and energy) and scaling the UCY load. The UCY load (4.8MW peak), which was scaled down based on a time series of actual loads at UCY campus, resulted in a 9.6kW peak load and it was emulated by the controllable resistive load. Only 2kW/2kWh of the VRB battery capacity was utilised as to match the down-scaled μ G ratings. Fig. 2 illustrates the diagram of the experimental setup with the down-scaled values of the components.

In the SYSLAB setup, the central power generation in Cyprus could either be represented by the diesel-generator

set (with a capacity of 60kVA), and thereby operated in island mode, or by a connection to the public grid. Due to various technical/practical problems and time constraints, the first option was never realised.

A wind turbine with a rated capacity of 10kW (in practice 5kW) could also be included, representing the wind power in Cyprus. Additionally, the power load in Cyprus could be represented in SYSLAB by a controllable dump load, controlled by time series measurements of the actual total power loads in Cyprus. As the diesel-generator option was never realised, both of these options were not relevant.

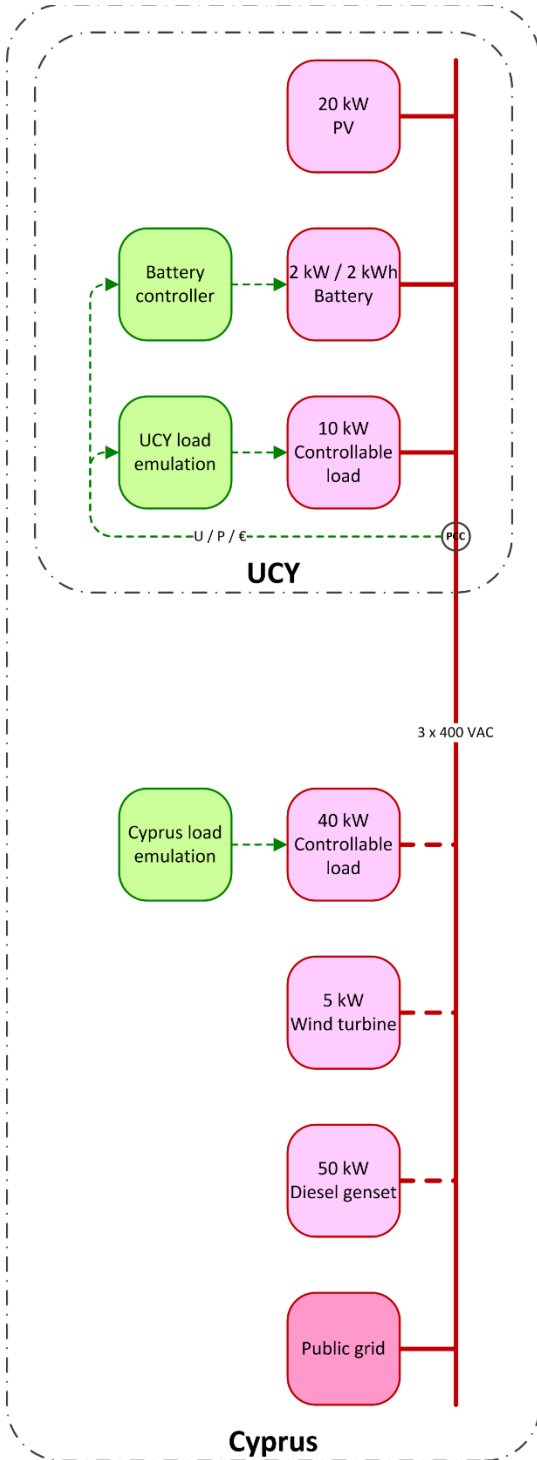

Figure 2. Diagram of the experimental setup at SYSLAB.

Therefore, the experiment was set up with a connection to the DTU grid rather in an islanded mode and the main target was to study how the voltage at the PCC was affected by the control algorithm energy management. The actual experimental setup at SYSLAB is shown in Fig. 3.

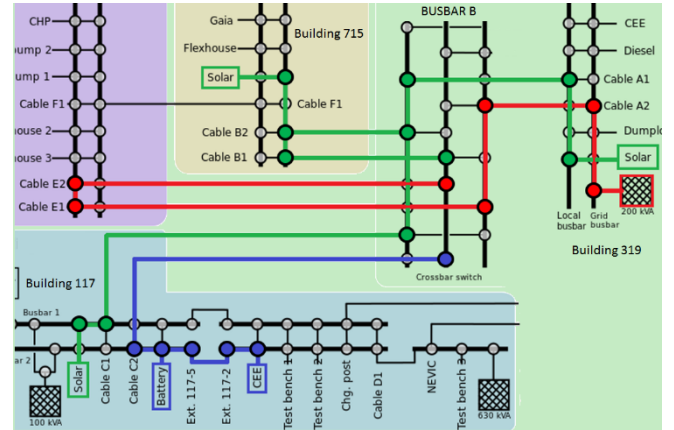

Figure 3. Diagram of the actual experimental setup at SYSLAB showing the switchboard connections. The PCC is replicated by Busbar B.

The 20kW PV consisted of three different PV sites within DTU (“Solar” nodes) connected together on the same busbar and then connected via cable B₁ to the PCC. The battery (“Battery” node) and the controllable resistive load (“CEE” node) were connected on the same busbar and then via cable C₂ to the PCC. The PCC was connected to the grid via a long cable (E₂-E₁-A₂) to represent the UCY Campus PCC connection to the distribution substation of the national grid.

All the measurements, which were done via electricity meters at each busbar node, were recorded at 1 second intervals.

The various voltage and power values were measured at the following points:

- 1) Grid: Building 319, Cable A₂ with Grid busbar node;
- 2) PCC: Building 319, Cable E₂ with Busbar B node;
- 3) PV: Building 715, Cable B₁ with Busbar 2 node;
- 4) Battery: Building 117, Battery node;
- 5) Load: Building 117, CEE node.

V. METHODOLOGY

The hardware in the loop method was used in order to emulate the UCY load profile by using a resistive load. The UCY load profile was introduced into Matlab and a control algorithm was developed by using a Script for managing the battery power and energy. The Script uses Java commands in the background to communicate with the battery and the resistive load in order to set the power demand [6]. What is more, there is communication with various electricity meters for measuring the voltage and power at the PV, battery, load and grid nodes.

The control algorithm was based on the current tariff scheme of UCY which falls within the Tariff 66 as

contracted by EAC and the electricity bill is based on Time of Use (ToU) tariffs as shown in Table I.

TABLE I. TARIFF PERIODS

	Hours
Off-Peak Period	23:00 – 07:00
Peak Period (June to September and from Monday to Friday inclusive)	09:00 – 17:00
Intermediate Period	all remaining hours

The tariffs differentiate based on the “Monthly Load Factor” (LF) which is the average load expressed as a percentage of the peak load. It is calculated as the ratio of the total energy consumption recorded during the month to the maximum demand. For the load profile being used, the LF for UCY lies between 31-60%. Table II summarizes the costs based on the monthly LF and the time periods.

TABLE II. TIME OF USE TARIFFS FOR UCY BASED ON LF

	Monthly Load Factor (LF)		
	0-30%	31-60%	61-100%
For every kVA of the Monthly Maximum Demand recorded during Peak Periods, depending on the Monthly LF	€13.99	€15.81	€16.99
For every kVA of the Monthly Maximum Demand recorded during Intermediate Periods, depending on the Monthly LF	€1.36	€1.97	€4.54
Per unit (kWh) charge during Peak Periods, depending on the Monthly LF	€0.1604	€0.1268	€0.1159
Per unit (kWh) charge during Intermediate Periods, depending on the Monthly LF	€0.1276	€0.1197	€0.1075
Per unit (kWh) charge during Off-Peak Periods, depending on the monthly LF	€0.1087	€0.1059	€0.1048

The battery control algorithm was designed so that the electricity bill is minimized. To achieve this, the hours of a day were divided into the different tariff periods. During the Off-Peak period, when the kWh tariff is the lowest, the battery charges at a constant rate of 2kW up to 50% from the grid in order to make peak shaving possible during the next day until there is PV power available. On the other hand, during the Peak period the battery charges only if the PV production is higher than the load consumption, otherwise it discharges only if the load is higher than a predetermined threshold (load shave value) and only if the State of Charge (SOC) is sufficient. The same applies for the Intermediate period. This was done, in order to avoid dealing with the high costs of the monthly maximum kVA demands during Peak and Intermediate hours.

At each time step and at the end of the 24-hour simulation, the electricity bill cost (based on actual power values, not scaled down) was calculated respectively for 30 days by using equations (1, 2 and 3). The same PV and load profile were assumed for each day.

$$\text{Cost}_{\text{kWh}} = \text{Cost}_{\text{kWh_OffPeakHours}} + \text{Cost}_{\text{kWh_PeakHours}} + \text{Cost}_{\text{kWh_InterHours}} \quad (1)$$

$$\text{Cost}_{\text{kVA}} = \text{Cost}_{\text{kVA_PeakHours}} + \text{Cost}_{\text{kVA_InterHours}} \quad (2)$$

$$\text{Cost}_{\text{Total}} = \text{Cost}_{\text{kWh}} + \text{Cost}_{\text{kVA}} \quad (3)$$

Prior to the experimental results, the same control algorithm was used in Matlab simulations [7], [8] for different load peak shave values in order to find the optimum value which will result in the lowest electricity bill [9].

All references to power values in the methodology refer to scaled-down values.

VI. RESULTS

The results obtained from the experiment are presented in this section.

The simulation results for finding the optimum peak shave value are shown in Table III. The optimum peak shave value was found to be 4.8kW which represents the real 2.4MW UCY load. The calculated cost based on the real UCY load denotes that there will be a saving of €138,600 per month compared to the case without the PV and BESS.

TABLE III. SIMULATED MONTHLY COST OF THE PV WITH BESS BY ASSUMING THE SAME PV AND LOAD PROFILE EVERY DAY

Condition	Monthly Demand and Cost				
	Load Shave (kW)	Cost kWh per Month (€)	Peak Hours Cost kVA per Month (€)	Intermediate Hours Cost kVA per Month (€)	Total Cost per Month (€)
no PV no BESS	NA	289,740	80,190	7,940	377,870
PV+ BESS	1.8	188,540	55,450	7,770	251,760
PV+ BESS	2.8	188,540	55,450	7,770	251,760
PV+ BESS	3.8	188,540	55,450	7,770	251,760
PV+ BESS	4.8	188,630	42,880	7,770	239,270
PV+ BESS	5.8	188,740	48,260	7,770	244,770
PV+ BESS	6.8	188,850	55,450	7,050	251,360
PV+ BESS	7.8	191,020	55,450	7,770	254,240
PV+ BESS	8.8	191,020	55,450	7,770	254,240

The optimal peak shave value of 4.8kW which was found by the simulation was used for the experimental setup at SYSLAB. Fig. 4 presents the future load variation of the UCY campus, the PV production, the battery demand and the net load (grid power).

During the Intermediate hours (07:00-09:00), the battery supplies power (positive power) to the load in order to achieve peak shaving due to insufficient PV production. When the PV production exceeds the load, power is exported (negative power) to the grid or it is used to charge (negative power) the battery if required. As it can be seen, this occurs during Peak hours at which the PV production is high. In addition, peak shaving occurs during peak hours (15:30-17:00). During the Off-Peak hours (23:00-07:00) when the kWh tariff is the lowest, the battery is charged up to 50% from the grid in order to make peak shaving possible during the next day. Therefore, the control algorithm behaves as expected.

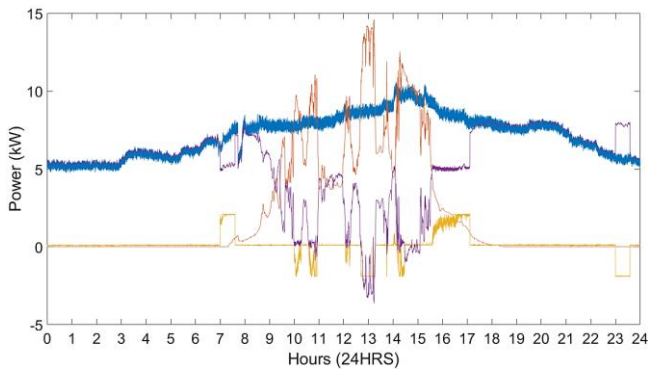

Figure 4. Power measurements of UCY load (blue), PV production (orange), battery demand (yellow) and net load (grid power) (purple).

Fig. 5 depicts the voltage levels for the grid, the PCC, the battery and the PV. The results obtained by the simulation show no rating violations of grid assets and operation as the voltage of the battery, the PV and PCC tend to follow the voltage of the grid, being within the nominal range and system limits. This was expected as the PV and battery systems are relatively small in capacity compared to the grid.

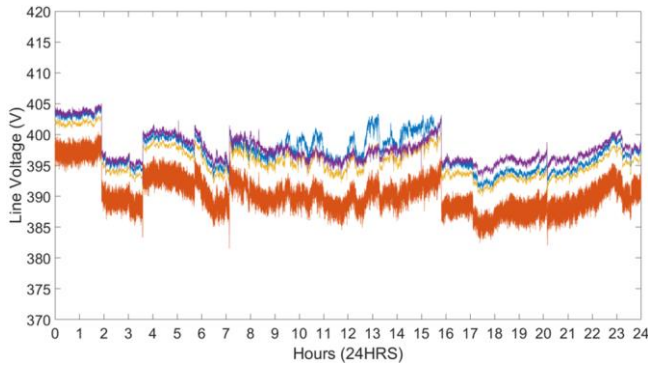

Figure 5. Voltage levels of the PV (blue), the battery (orange), the PCC (yellow) and the grid (purple).

As already stated, the battery control algorithm was designed so that the PV plant can supply the UCY load while the excess energy will be injected to the grid or will be used to charge the battery. When the energy produced by the PV system is not sufficient to fulfill the load demand, the battery will cover the energy deficit. As it can be seen in Fig. 6, the battery charges and discharges according to the demanded power by the control algorithm and its charge is within the predefined SOC limits.

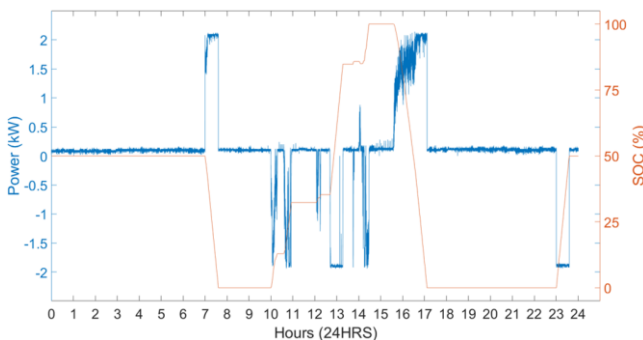

Figure 6. Power demand (blue) and SOC (orange) of the battery.

VII. CONCLUSIONS

The University of Cyprus (UCY) strives to become a carbon neutral institution through the implementation of a microgrid (μ G) with a 10MWp photovoltaic (PV) plant and 1MWh/1MWh battery making the whole university a net-zero energy campus. This provided the opportunity to study the integration of these technologies with the national grid and the development of a control algorithm for the optimum energy management.

In this paper, the control algorithm parameters were optimised by using Matlab through numerous simulations in order to reduce the electricity bill of UCY. It was found that savings of €138,600 per month can be achieved with the proposed μ G compared to a system without PV and storage.

The developed control algorithm was also tested at SYSLAB to study the voltage variation at the point of common coupling (PCC). The experimental results showed a steady-state voltage at the PCC. The peak shaving control algorithm has shown promising results, however, if the PV production is insufficient, the battery capacity will not be enough to achieve peak shaving and hence reduce the electricity bill.

Peak shaving is important for UCY because the kVA per month is charged at a high premium. Also, peak shaving can achieve a higher load factor (LF) and hence reduce the kWh rating of the UCY electricity bill.

Work is currently being undertaken on developing an algorithm for optimizing the required PV power and battery size (power and capacity), control and technology based on the University's load profile and the solar insolation in Cyprus. The cost of the proposed solution and operational reliability/flexibility of the system will be compared for a centralized and distributed storage solution with the use of SYSLAB.

ACKNOWLEDGEMENTS

This work is part of 'TwinPV - Stimulating scientific excellence through twinning in the quest for sustainable energy', a H2020 Twining project.

REFERENCES

- [1] A. Chaouachi, R. M. Kamel, R. Andoulsi, and K. N. Member, "Multiobjective Intelligent Energy Management for a Microgrid," no. c, pp. 1–12, 2011.
- [2] E. S. Committee, *IEEE Recommended Practice for Energy Management in Industrial and Commercial Facilities*, vol. 1995, no. Lcc. 1996.
- [3] O. Gehrke and H. Bindner, "Building a test platform for agents in power system control : Experience from SYSLAB."
- [4] "A. Ravichandran et al., 'The Critical Role of Microgrids in Transition to a Smarter Grid: A Technical Review', IEEE Transportation Electrification Conference and Expo (ITEC), 2013."
- [5] L. Mihet-popa, V. Groza, and F. Isleifsson, "Experimental Testing for Stability Analysis of Distributed Energy Resources Components with Storage Devices and Loads," 2012.
- [6] P. Petkov, *SYSLAB - an interactive system for analysis and*

design of linear multivariable systems. .

- [7] D. Quiggin, S. Cornell, M. Tierney, and R. Buswell, "A simulation and optimisation study: Towards a decentralised microgrid, using real world fluctuation data," *Energy*, vol. 41, no. 1, pp. 549–559, 2012.
- [8] S. Bando, Y. Sasaki, H. Asano, and S. Tagami, "Balancing control method of a microgrid with intermittent renewable energy generators and small battery storage," pp. 3–8, 2008.
- [9] L. Xu, S. Member, and D. Chen, "Control and Operation of a DC Microgrid With Variable Generation and Energy Storage," vol. 26, no. 4, pp. 2513–2522, 2011.