

THE  
PHYSICAL REVIEW.

---

ON THE IRREGULARITIES OF MOTION OF THE FOUCAULT  
PENDULUM.

BY A. C. LONGDEN.

**SYNOPSIS.** In a brief historical statement, emphasis is put upon the current opinion that a Foucault pendulum must be very long and very heavy in order to be successful. It is then shown that the elliptical motion so common in Foucault pendulum experiments is not due to insufficient length or weight, or even to atmospheric disturbances, but simply and solely to unequal freedom of motion in different directions. The disturbing influences are within the pendulum itself. Different forms of support and suspension are discussed, and methods of eliminating the disturbing influences are suggested. What the author describes as a double roller support is shown to be superior to any other form of support thus far proposed. With this support and a perfectly annealed double bifilar suspension, a  $2\frac{1}{2}$ -meter pendulum weighing a single kilogram succeeds perfectly.

**T**HE pendulum experiment of Léon Foucault, by means of which he demonstrated the axial rotation of the earth, is held in reverence by physicists and astronomers, not simply as one of the successful experiments of the nineteenth century, but as one of the brilliant experiments of all time.

Foucault began his work on this problem with a pendulum not more than 2 meters long, but finding the results unsatisfactory, he increased the length to 11 meters, and finally, under the great dome of the Pantheon, to 67 meters. Taking advantage of the height of the great cathedral towers of Europe, the experiment was more or less successfully repeated at Cologne, Reims, Amiens, St. Jacques, and elsewhere, where towers of great height could be made available.

Many attempts have been made to reduce this classic experiment to lecture room dimensions, but by common consent the short wire and small mass have been condemned as unsatisfactory. More than a score of well-known physicists and astronomers are on record as affirming that the Foucault pendulum must be very long and very heavy in order to give satisfactory results—some say, to prevent cross vibrations or to keep the pendulum from falling into an elliptical path. Many insist

that it must be set in motion with great care and protected from external disturbances, which, it is said, develop irregularities in its motion. In a recent article in a scientific journal on "A Laboratory Method of Demonstrating the Earth's Rotation," it is stated that the Foucault pendulum method is inapplicable in many laboratories because there is no convenient place to hang a sufficiently long and heavy pendulum.

We shall probably never be quite certain of the exact conditions under which Foucault's celebrated experiment was performed. Our sources of information, in addition to the very brief records of the French Academy of Sciences,<sup>1</sup> are the papers published by Mme. Foucault,<sup>2</sup> ten years after Foucault's death, and the contributions of Lissajous<sup>3</sup> and Flammarion,<sup>4</sup> published still later.

Most of the important information concerning the pendulum of the Pantheon in its final form, is found in one of the papers in Mme. Foucault's "Recuile," entitled "Explications sur l'expérience relative au mouvement de la terre." This paper was without date and had not been published by Foucault himself, though he is said to have published a similar paper in le Journal des Debats in March, 1851.

That the work was rushed through in great haste is indicated by Flammarion's statement that it was undertaken in January, 1851, and Mme. Foucault's statement that it was presented to the French Academy of Sciences, February 3 of the same year.

The records are not in perfect agreement concerning the dimensions of the pendulum in its final form, but the evidence is abundant that it consisted of a mass of 28 kilograms, suspended by a steel wire about 67 meters long, strained somewhat beyond its elastic limit. The fact that the wire was greatly strained is important later on.

A few years ago I set up a 60-foot Foucault pendulum consisting of an iron ball weighing about 8 kilograms, suspended by a No. 18 brass wire, from a tolerably good though by no means perfect double knife-edge support. The ball was provided with a spike at the bottom to enable the observer to determine its position, as it moved back and forth over a chart provided with a circular scale calibrated in degrees.

The performances of this pendulum were not very satisfactory and I attributed its partial failure to the presence of air currents in the shaft. However, after trying the pendulum a number of times, I found that its eccentric behavior was repeated over and over again in much the same

<sup>1</sup> *Compte Rendu*, t. XXXII., p. 135.

<sup>2</sup> *Recuile des Travaux Scientifiques de Léon Foucault*. Publié par Madame Veuve Foucault, Sa Mère. Paris, 1878.

<sup>3</sup> *Notice Historique sur la vie et les travaux de Léon Foucault*.

<sup>4</sup> *Notice scientifique sur la pendule du Panthéon*.

way. I could not convince myself that such *regular* "irregularities" were accidental, and I was quite sure they were not due to the uncertain shifting of air currents.

For the purpose of making a closer study of the Foucault pendulum and its behavior, I moved this pendulum to the lecture room, suspending the 8 kilogram ball from a more carefully constructed double knife-edge support attached to one of the ceiling beams over the lecture table. The pendulum was now a little more than  $2\frac{1}{2}$  meters long. It was started swinging by tying the ball back and burning the thread, in the usual way. It was allowed to swing through an arc of about  $10^\circ$ .

A few preliminary experiments gave me reason to believe that none of the seemingly irregular movements of the pendulum were in any way chance or accidental, but that they could all be produced and reproduced under perfectly definite conditions.

The double knife-edge support used is shown in detail in Figs. 1 and 2.

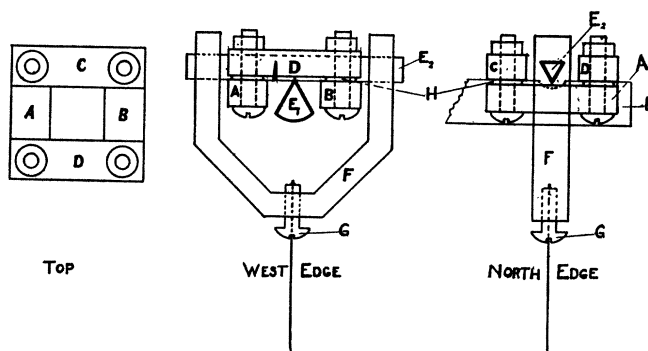

Figs. 1 and 2.

$E_1$  and  $E_2$  are the knife-edges,  $ABCD$ , the rocker, consisting of hardened and polished steel plates bolted together at the corners, and  $F$ , a brass hanger, carrying the wire in a machine screw,  $G$ , which facilitates substituting one wire for another.

The upper knife-edge could be raised or lowered by varying the vertical distance between the plates of which the rocker was made. This might be done by means of micrometer screws, but in these experiments it was done by inserting thin metal plates between the upper and lower halves of the rocker, as at  $H$ , in Figs. 1 and 2.

With this support the behavior was that of a Blackburn pendulum with slightly different periods in two directions at right angles to each other. Since the elliptical motion of a Blackburn pendulum depends upon the ratio of these two periods, it ought to be possible to adjust

the distance between the planes of the double knife-edge support in such a way as to get any desired amount of eccentricity, or to eliminate it altogether.

In one of the preliminary experiments with the double knife-edge support adjusted at random, the pendulum started on its elliptical path,

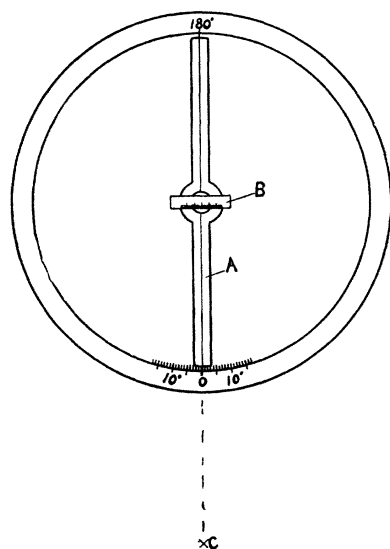

Fig. 3.

rotating clockwise as viewed from above; and I noticed that as the minor axis of the ellipse increased in length, the shift of the plane of vibration of the pendulum, as marked by the position of the major axis of the ellipse, increased at an abnormal rate. After verifying this fact by repeated observations, I undertook to investigate the relation of the length of the minor axis of the ellipse, to the position of the major axis.

I placed a movable index, *A*, Fig. 3, upon the circular scale over which the pendulum was swinging and mounted a scale of millimeters, *B*, at right angles to it at the center of the circle. The index consisted of a

light wooden bar with a screw running through it at the center, and with a fine black line running lengthwise along the bar from zero to  $180^\circ$  on the scale.

With a pendulum provided with a sharp spike travelling close to the black line on the movable index, and with a suitable lens placed as at

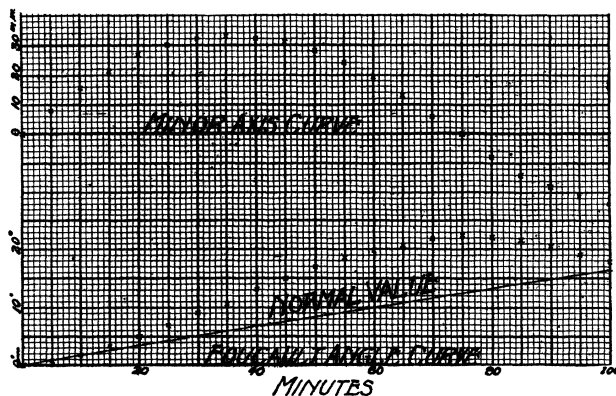

Fig. 4.

*C*, in Fig. 3, it is always possible to read the length of the minor axis of the ellipse to single millimeters and in many cases to approximate tenths of millimeters; while the position of the major axis can be read to within  $\frac{1}{10}^\circ$  with ease and certainty, or to  $\frac{1}{100}^\circ$  approximately.

Starting the pendulum swinging from north to south, with an amplitude of 20 centimeters (an arc of about  $9^\circ$ ), I read the length of the minor axis of the ellipse, and the angle between the major axis and the meridian every 5 minutes for an hour and three quarters. The results are tabulated below and plotted in the curves shown in Fig. 4. In the column marked "Direction of Rotation," clockwise or direct is marked "*D*," and counterclockwise or reverse is marked "*R*." In the plot, the minor axis curve is above and the curve representing the position of the major axis in angular displacement from the meridian, and which we shall hereafter call the Foucault angle curve, is below. The length of the minor axis is in millimeters and the Foucault angle is in degrees, on the *Y* axis. Both are in minutes on the *X* axis. The full curves are not actually drawn, because the points plotted are so close together that it was not thought necessary to connect them.

Time in Minutes.	Minor Axis in Mm.	Direction of Rotation.	Foucault Angle in Degrees.
0	0		0
5	8.0	D	.65
10	15.5	"	1.8
15	21.0	"	3.1
20	26.2	"	5.0
25	30.0	"	6.8
30	32.0	"	9.0
35	32.5	"	10.5
40	32.0	"	13.0
45	30.5	"	14.9
50	28.0	"	16.9
55	24.0	"	18.5
60	19.2	"	19.85
65	13.0	"	20.8
70	6.0	"	21.8
75	0	"	22.2
80	8.0	R	22.1
85	14.0	"	21.6
90	18.0	"	20.3
95	21.5	"	18.9
100	24.0	"	17.7

The minor axis curve is certainly a close approach to a simple sine curve. It probably would be a perfect sine curve if it were not for the fact that the amplitude of the pendulum is diminishing all the time and this affects the length of the minor axis of the ellipse as well as the major axis.

Note that the length of the minor axis increased to 32.5 millimeters in 35 minutes and then diminished to zero at the end of 75 minutes, when it crossed the  $X$  axis of the plot and the pendulum began to rotate counterclockwise. Note also that while the pendulum was rotating clockwise, the Foucault angle increased abnormally; but that when the pendulum began to rotate counterclockwise, the Foucault angle began to diminish.

The calculated value of the Foucault angle for the latitude of Galesburg is  $9.83^\circ$  per hour. The straight line in the Foucault angle plot, running from the origin to the  $9.83^\circ$  point at the 60-minute line, represents this value. It will be noted that the plotted curve is much above this line most of the time, but that it reaches its greatest height and starts down again when the minor axis curve falls below the  $X$  axis of the plot, that is, when the pendulum begins to rotate counterclockwise.

At the end of this series of observations the pendulum was accidentally thrown out of adjustment. After readjusting, it was started swinging in the usual way, but this time it started rotating counterclockwise, and continued rotating in that direction during the entire series of

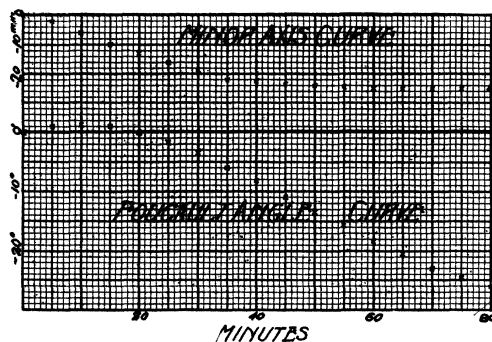

Fig. 5.

observations which followed. That is, it did not complete a half cycle and reverse its direction of rotation as it did in the preceding series.

The curves for this series are shown in Fig. 5.

Our first glance at these curves failed to reveal the fact that they had anything in common with those in Fig. 4, but further inspection shows that they are alike in the fact that they both show that counterclockwise rotation of the pendulum tends to reverse the direction in which its plane of vibration is shifting.

However, I had in Fig. 4 a part of a cycle in which the rotation of the pendulum was mostly clockwise, and in Fig. 5 a part of a cycle in which the rotation was entirely counterclockwise.

It then occurred to me to shorten the cycle, so that I might have an opportunity to compare the minor axis curve with the Foucault angle curve through several complete cycles, before the amplitude of the pendulum became very greatly reduced. This was easily accomplished by readjusting the distance between the planes of the double knife-edge support, so as to change the length of the pendulum in one direction without changing it in the other.

After adjusting the support for about 3 or 4 cycles per hour, I made the series of observations represented in the curves shown in Fig. 6.

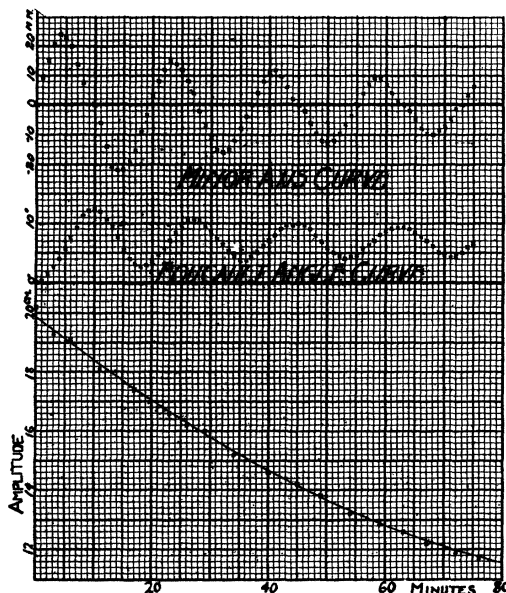

Fig. 6.

In this series, both readings were made *every minute* for an hour and a quarter. Also occasional readings of the amplitude of vibration of the pendulum, along the major axis of the ellipse, for the purpose of determining the decrement.

These curves show in a most striking manner, the relation of the elliptical motion of the pendulum to the shift in its plane of vibration. In every case, when the direction of rotation changes (when the minor axis curve changes sign) the direction of the shift in the plane of vibration also changes. Expressing it in another way, whenever the rotation of the pendulum is clockwise, the Foucault angle is increasing, and whenever the rotation is counterclockwise, the Foucault angle is decreasing. There is a slight time lag as the Foucault angle curve rises, and the

reverse as it falls, because the net effect plotted is the minor axis effect plus or minus the real Foucault effect.

At this point I thought my troubles were over, for it now seemed that in order to get a normal Foucault angle, it would only be necessary to adjust the double knife-edge support for equal lengths of the pendulum in both directions. Then there would be no elliptical motion, and consequently no shifting of the plane of vibration except that due to the rotation of the earth on its axis,—the normal Foucault angle.

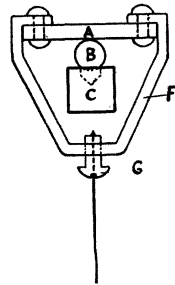

Fig. 7.

I expected to arrive with very little difficulty at an adjustment which would eliminate the elliptical motion, but all my efforts in this direction were futile. In sheer desperation I abandoned the double knife-edge and designed the following ball and plane support:

In Fig. 7, *A*, is the edge of a hardened steel plate 30 millimeters square. The lower surface of this plate is plane and highly polished. It rests at its center upon a polished steel ball, *B*, which in turn rests in a depression drilled in the upper side of a square steel rod, the end of which is shown at *C*. The hanger, *F*, is symmetrical, having four arms (only two are shown in the drawing) running obliquely down from the four corners of the plate to the small brass plate carrying the machine screw, *G*, through which the suspension wire passes.

As this hanger was perfectly symmetrical, and the pendulum free to swing in any direction from the upper surface of the ball as its point of suspension, it seemed that there could be no possibility of elliptical motion due to difference of length in two directions. Still the elliptical motion persisted.

In the first experiment with the ball and plane support, the minor axis of the elliptical path of the pendulum would increase to a maximum, the rotation being in one direction, then the axis would shorten to zero and rotation would begin in the opposite direction. These changes in the length of the minor axis of the ellipse, accompanied by corresponding changes in the direction of rotation of the pendulum, followed each other with great regularity.

This elliptical path seemed to be a splendid example of a resultant of two simple harmonic motions at right angles to each other and differing in period by a small amount which could be easily calculated, or which could be determined experimentally. Since I had eliminated the possibility of the pendulum having two lengths in different directions, by the use of the ball and plane support, I wrongly attributed the elliptical



motion to unevenness in the wire, although numerous measurements failed to reveal any great lack of roundness and there was nothing to indicate imperfections of any kind. I could not see that it would have made any difference if the wire had not been round or even if it had been more flexible in one direction than in the other, for with the ball and plane support, the pendulum was perfectly free to swing in any direction and the wire was not expected to bend at all. It was expected to swing with perfect freedom from the point of contact between the ball and plane. The correctness of this assumption was demonstrated later by substituting a flat steel ribbon for a round wire.

Nevertheless the pendulum behaved as if it had two periods. Furthermore it *always started* rotating clockwise, *never* counterclockwise. This fact remained a puzzle until another wire was substituted for the wire which I had been using. The two wires were cut from the same piece, and were certainly as nearly alike as two wires could well be, and yet the pendulum now *invariably* started rotating *counterclockwise—never clockwise*.

I immediately hit upon the curl in the wire as the cause of the elliptical motion. The wire was brass spring wire, and had been lying in a coil about 25 centimeters in diameter, until the "set" in it was very pronounced.

After starting the pendulum a number of times with the new wire and getting always the same results, *counterclockwise* motion at the start, I rotated the *wire* 180 degrees on its own axis, without disturbing either the pendulum ball or the support. The wire may be rotated by turning the screw *G*, Fig. 7, without disturbing the hanger, and a similar arrangement at the bottom enables us to rotate the wire without rotating the ball. Now, the pendulum started rotating *clockwise*.

In a series of experiments which followed, for the purpose of studying the effects of the curl in the wire, I decided not to use the ball and plane support on account of its tendency to rotate at the upper surface of the ball.

The ball and plane support has no advantage over a perfectly constructed double knife-edge support. It even has some disadvantages; but it at least proved valuable in detecting some of the defects in the wire, which perhaps would not have been detected otherwise.

In order to eliminate the effects due to the rotation of the hanger in the ball and plane support, and also the possibility of two periods, resulting from lack of perfect adjustment of the double knife-edge support, and yet to retain a rotary adjustment of the wire, I designed the following torsion head plate support.

*A*, in Fig. 8, is a cast iron cylinder, 30 millimeters long and having an internal diameter of 30 millimeters. It is bored true on the inside and faced at the ends. *B, B*, are steel rods, 13 millimeters in diameter, screwed into shoulders on opposite sides of the cylinder. These rods are held in strong clamps attached to the ceiling beam. *C* is a brass head plate 10 millimeters thick, and turned in the lathe to fit into the cylinder as shown. A circular scale, not shown in the drawing, is cut

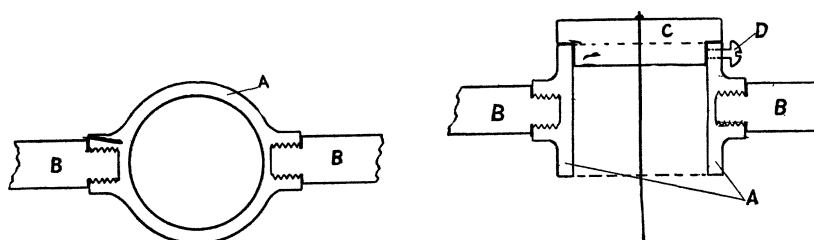

Fig. 8.

upon the edge of the head plate, and a reference mark is placed on the side of the cylinder, so that when the head plate, carrying the wire, is rotated, its position can be read on the scale on its edge. *D* is a set screw, to hold the head plate firmly in any desired position. There are three of these set screws, placed 120 degrees apart, in order to prevent any slight tendency to wobble.

As the wire must bend at the lower edge of the head plate when the

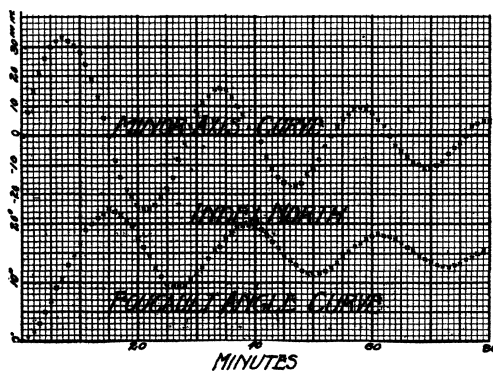

Fig. 9.

pendulum swings, it is important that there should be no looseness at this point, and particularly that there should be no greater freedom of motion in one direction than in another.

To realize these conditions, the hole in the head plate was drilled

from the upper side and the plate was faced on the lower side afterwards, leaving the edges of the hole perfectly sharp at the circumference of the wire. The hole was made with a drill a size smaller than the wire. The plate was then heated and put in place on the wire by the "shrinking on" process. Finally, the wire was bent over and soldered at the upper surface of the plate, to prevent its being pulled out when the weight was placed upon it.

It is also important that the ceiling beam or other structural element to which this support is clamped, should be as rigid as possible, for it is obvious that any lack of rigidity in the support would be likely to offer greater freedom of motion in one direction than in another.

The experiments with this form of support were conducted with a steel piano wire a trifle more than a millimeter in diameter, as a suspension. The wire had been lying in a closely bound coil, 10 centimeters in diameter, and when opened up, the coil expanded to a diameter of 19 centimeters.

In the first experiment it was my intention to adjust the torsion head so that the convex side of the wire would be in some particular direction,—say north; but, as the wire,  $2\frac{1}{2}$  meters long, curled several times between its extremities, the position of the convex side was different at different points. It would be difficult to determine the direction in which the resultant of all the forces exerted by the wire acted upon the pendulum. However, assuming that such a resultant acted in some direction and produced a definite effect upon the motion of the pendulum, an index was placed upon the torsion head, so that any position arbitrarily chosen could be noted.

A series of observations was then made, on the position of the plane of vibration of the pendulum, and the length of the minor axis of its elliptical path, with the index on the torsion head pointing north. The results are shown in Fig. 9. The wire was then rotated  $45^\circ$  clockwise (index northeast), and another series of observations made. The results are shown in Fig. 10. In Fig. 10 and the succeeding figures, the minor axis curve is marked *A*, and the Foucault angle curve, *B*. Other observations were made with the index in other positions as shown in the curves down to and including Fig. 16.

A simple inspection of these curves in pairs leaves no room for doubt about the correctness of our inference from the curves in Fig. 6. In every case, the dependence of the Foucault angle curve upon the minor axis curve is obvious. Whatever the *cause* of the elliptical motion, the *effect* is a perfectly definite shift in the plane of vibration. In the present case, the elliptical motion was due to elastic reactions in a highly tempered steel wire.

To produce a perfect Foucault pendulum the disturbing effect dependent upon the double knife-edge is easily controlled by adjustment. The effect due to the elastic reactions within the wire, ought to be eliminated by *annealing the wire*. A number of more or less successful attempts in this direction were made.

In one experiment with the torsion head plate support I used a rather poorly annealed iron wire. The observations on this wire are shown in Fig. 17. I could not believe my observations had been so careless as the kinks in these curves indicated, but I repeated the series about

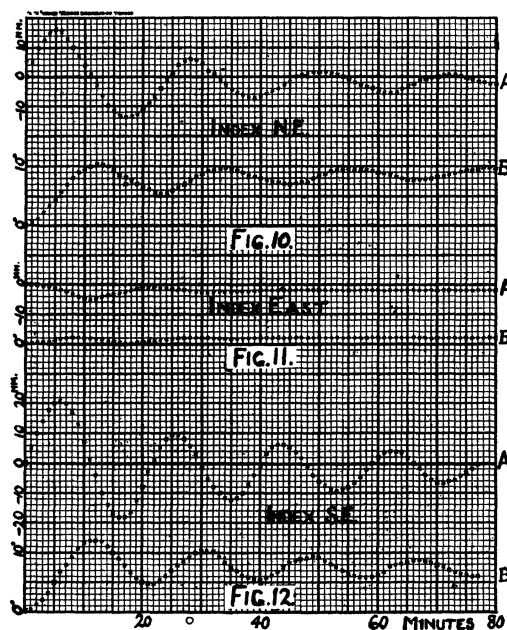

Figs. 10, 11, 12.

sixteen hours later, the pendulum having remained undisturbed during the interval. This time I got the results indicated in Fig. 18.

The curves in Fig. 18 show the same irregularities as those in Fig. 17, but in a less pronounced degree. The wire was gradually straightening out, under the influence of the weight which was upon it. The irregularities are less conspicuous in the Foucault angle curves than in the minor axis curves. In fact they are not perceptible in the Foucault angle curve in Fig. 18. I have drawn a smooth curve through both the Foucault angle curves from the 39 minute point to the 82 minute point. This hits practically every point on the Foucault angle curve in Fig. 18, but shows perceptible variations from it in Fig. 17, at about 58, 72, and 78 minutes.

I then ran a Bunsen burner flame up and down the entire length of the wire several times as it hung with the 8 kilogram weight upon it; after which, a third series of observations resulted as shown in Fig. 19. The kinks are entirely smoothed out of both curves. Evidently I had finished annealing the wire. If this wire had not been required to bend at the point of suspension, that is, if it had been used with a double knife-edge support instead of a torsion head plate support, it might have been a good Foucault pendulum after it was perfectly annealed.

To illustrate the effect of continued bending upon very soft wire I cite the following case: The 8 kilogram ball was suspended by a No. 18

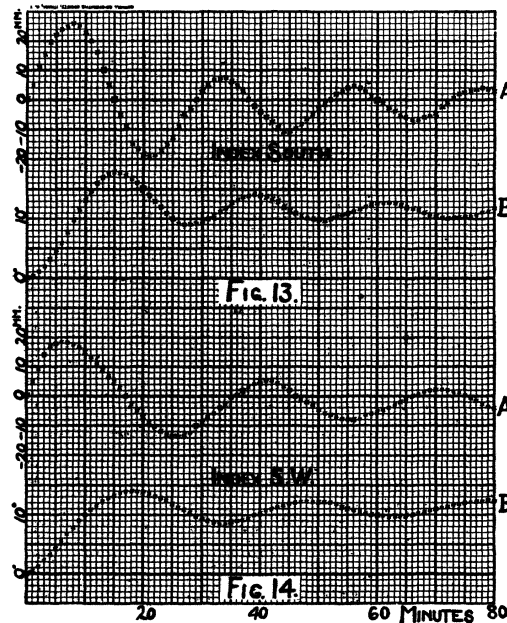

Figs. 13, 14.

(B. & S. gauge) soft copper wire capable of sustaining a steady pull of about 30 kilograms. The upper end of this wire was soldered into a No. 60 hole (drill gauge size) in a brass torsion head plate. This pendulum was started swinging with an amplitude of 20 centimeters and ran with no perceptible tendency toward elliptical motion and with no perceptible variation from the true Foucault angle, but the wire became brittle and broke off close up to the plate after running about five minutes.

Any wire which is required to bend at the point of suspension must not only be perfectly annealed and perfectly round and perfectly homogeneous in all respects, but it must also be free from wear at the point of

suspension and it must not be allowed to become brittle at the point where it bends. There are so many chances of violating one or more of these requirements that we may hardly expect success with a torsion head plate support.

The double knife-edge support is ideal in some respects but it has one defect which must be looked upon as serious. The knife-edges must be *perfectly sharp* and the planes upon which they rest must be so *hard* that the knife-edges will not cut them *in any degree whatever*. These are conditions which can not be fully realized, and if realized, could not be maintained. Any wear on the knife-edges converts them into cylindrical bearings, and any wear on the planes upon which they

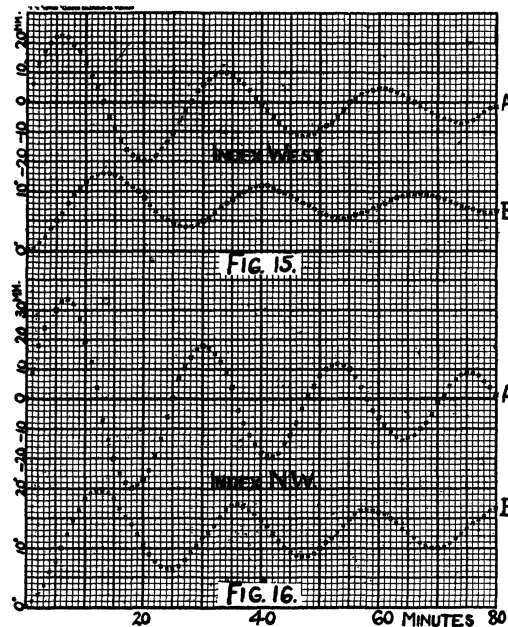

Fig. 15, 16.

rest converts them into cylindrical troughs, so that after a time we have a cylinder rolling inside of a larger cylinder instead of a knife-edge resting upon a plane. The axis of suspension of a pendulum with a knife-edge support is at the surface of the plane upon which the knife-edge rests; but if a cylindrical roller be substituted for the knife-edge, the axis of suspension of the pendulum is no longer at the surface of the plane but at the center of the roller. We have therefore changed the length of the pendulum by an amount equal to the radius of the cylindrical roller. As the knife-edges wear, the effective length of the pendulum is

increased in one direction and diminished in the other and our Foucault pendulum is gradually converted into a Blackburn pendulum.

Of course the wear can be compensated for by readjusting the distance between the planes, or in some cases by means of a counterpoise above the support; but these adjustments are really somewhat difficult to make, and as the wear continues the pendulum is never in a perfectly satisfactory condition.

The most satisfactory support which I have been able to construct is a double roller support, in which hard polished steel rollers of considerable size have been deliberately substituted for knife-edges. The wear

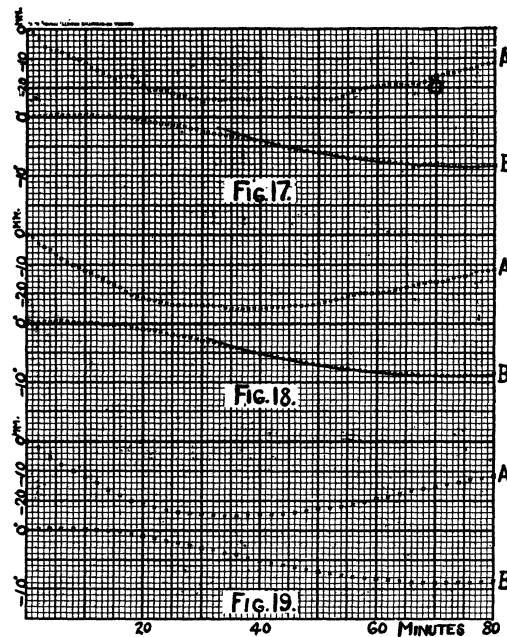

Figs. 17, 18, 19.

is thus reduced to an inappreciable minimum, the radius of curvature is perfectly definite and constant and the adjustment when once made is permanent.

This support is simple and easily constructed and possesses a number of features which ought to recommend it. The details of construction are shown in Fig. 20.

A is a hard steel plate, 25 millimeters square and 3 millimeters thick, with shallow grooves in the upper and lower surfaces at right angles to each other as shown at B. The bearing surfaces, C, and the hardened steel rollers, D and E, which are in contact with them, are highly polished.

A double bifilar suspension,  $F$ , is used, consisting of soft copper wire small enough to be easily stretched when the weight of the ball,  $L$ , rests upon it. No. 30 (B. & S. gauge) is a suitable size for a 1 kilogram ball. The wire is simply looped over the ends of the upper roller, and *under* the ends of a short crossbar,  $K$ , at the top of the ball,  $L$ . Shallow grooves may be cut near the ends of the roller and crossbar, to keep the wire from slipping. If the wires are not quite equal in length, they may be equalized by carefully administering a gentle pressure directly downward upon the ball, while the upper roller is held rigidly in a horizontal

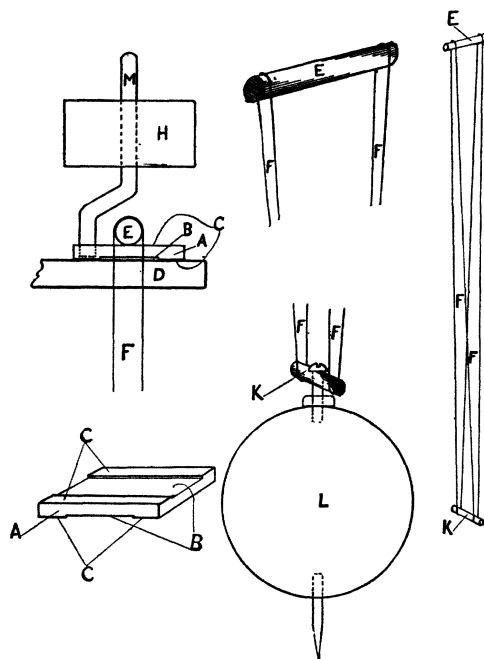

Fig. 20.

position. The lower roller,  $D$ , acts as fixed support and should be rigidly held in its position by means of a strong clamp of some kind. If  $D$  is mounted in an east and west position, when the pendulum is swinging east and west, the upper roller,  $E$ , rolls on the plate,  $A$ . When the pendulum is swinging north and south, the plate,  $A$ , rocks upon the lower roller,  $D$ .  $H$  is a counterpoise to compensate for the difference of length of the pendulum in the two directions. This counterpoise may be run up or down on the threaded rod,  $M$ . (Threads not shown in the drawing.) When  $H$  is properly adjusted, the period of the pendulum is the same in both directions. There is then no elliptical motion and no



shift in the plane of vibration of the pendulum, except that due to the rotation of the earth upon its axis.

In the apparatus which I have just described, the rollers are 6.35 millimeters in diameter and the counterpoise weighs 140 grams. The counterpoise is provided with a circular scale to facilitate fine adjustment. Of course the adjustment is affected not only by the mass and position of the counterpoise, but also by the thickness of the rollers and the thickness of the plate. It is also true that changing the angle between the rollers will disturb the adjustment. For this reason, great care should be exercised in making other adjustments, not to shift the position of the upper roller or the plate. Within small limits, canting the upper roller might be used as a method of adjusting.

It has been shown that the tendency of the pendulum to run in an elliptical path may be the result of any one or more of a variety of causes, but whatever the cause, we may always develop a counter tendency by raising or lowering the counterpoise in the device now under consideration, and perfect compensation is always possible. Of course, the final adjustment must always be made by experiment, and although the process may be a little tedious, it is not difficult, and when once made, the results are all that could be desired.

If the amplitude of the pendulum is large, there is a tendency of the rollers to slip on the polished surfaces of the plate. I find an amplitude of 20 centimeters (40 centimeter path) is very satisfactory for a pendulum  $2\frac{1}{2}$  meters long.

The double roller support used in connection with a double bifilar suspension of soft copper wire is so satisfactory that I do not find it necessary to use a pendulum having a length of more than  $2\frac{1}{2}$  meters or a mass of more than 1 kilogram. In fact I have been quite successful with a pendulum only one meter long and weighing only 240 grams, but of course there is no need of going to such an extreme as this, except to demonstrate that it can be done. A pendulum weighing a kilogram, and swinging over the lecture table, from a rigid beam in the ceiling of the lecture room, is ideal.

Foucault unquestionably succeeded in minimizing his difficulties by using a very long and very heavy pendulum, but his results may not have been as exact as some of us have supposed. I find nothing in any of the original papers or early comments upon them, to indicate a high degree of accuracy. Indeed the only statements bearing upon this point indicate that the results of the experiment were only approximately correct. For example: "Quoique ces oscillations diminuent d'amplitude assez rapidement, au bout de cinq à six heures elles sont encore assez

grandes pour permettre d'observer la déviation que est alors de 60 à 70 degrés." Or, "La montre à la main, ou voit que, à Paris, la déviation est du un degré en cinq minutes."

Such statements can not be thought of as representing precise measurements. They are good enough to leave no doubt in regard to the general proposition that the earth rotates on its axis, but they are not by any means exact. If success depends upon great length and great mass, Foucault's results ought to have been very exact. The fact that they were not, indicates that there was something else to be reckoned with. I have already referred to the fact that his wire was strained beyond its elastic limit, and I have no doubt this condition of the wire contributed to his success quite as much as its great length. Of course the great mass of the ball was responsible for the strain upon the wire, but if the wire had been *annealed*, the great mass would not have been necessary.

To use a pendulum of very great mass in order to prevent atmospheric disturbances is also quite unnecessary. Air currents, if forcible enough, do disturb the pendulum slightly, but such disturbances never "develop large irregularities" in the motion of the pendulum, in spite of certain ingenious theories intended to explain how they do it. In fact they never *develop* any irregularities at all. They always die out gradually, and at the same rate as the decrement in the principal motion of the pendulum along the major axis of the ellipse, when the amplitude has been reduced to the same value. Would you dare present any other view of the case to your students if you were discussing the second law of motion?

How unimportant slight atmospheric disturbances are, may be indicated by the fact that I have succeeded perfectly with a 1 kilogram pendulum in an ordinary lecture room with all the doors and windows open (2 doors and 7 windows) and a good breeze flowing through the room.

The majestic oscillations of the Pendulum of the Pantheon, as Flammarion fittingly describes them, must have produced a profound impression upon those who had the good fortune to observe them; but it is not possible to repeat the experiment in every lecture room on such a magnificent scale. To reduce the experiment to convenient lecture room dimensions, ought to greatly extend its field of usefulness.

KNOX COLLEGE,  
GALESBURG, ILL.,  
October, 1918.