

A MERCURY VOLUMETER¹

By ERNEST F. GOODNER

ABSTRACT

A new volumeter using mercury as the liquid for determining volumes of solids.

Existing volumeters.—The eight principal volumeters which have been in use during the past few years are discussed, the disadvantages and advantages being pointed out and the requisites of a satisfactory volumeter are outlined.

Description of new mercury volumeter.—The volumeter consists of a burette which may be raised or lowered by means of a rack and pinion. To the lower end of the burette there is a rubber tube attached which connects at the other end with a reservoir. This reservoir is at a fixed point, level with the bottom of the burette when raised to its highest point and is partially filled with mercury. The whole volumeter is, in action, a large "U"-tube with one movable limb (the burette). The volume is obtained by placing the briquette in the reservoir, causing a rise in the level of the mercury in both limbs of the "U"-tube. The burette is then lowered until the mercury has resumed its former level, this movement being the measure of the volume which is read directly from the graduations on the burette.

Mathematical analysis.—It is shown that a ratio of 1:1 of the reservoir and burette areas of free mercury surface will enable the reading of volumes as accurately as one can obtain the burette reading.

Comparative tests with other volumeters.—Tests of the action of mercury, water and kerosene show that they behave alike in obtaining volumes. No saturation of burned or dry briquettes is necessary when using mercury as the liquid. Volumes with pycnometer and overflow types of volumeters checked those obtained with mercury volumeter to within $\frac{6}{100}$ a cc.

Per cent variation of readings.—Results of three operators working independently indicate that for volumes above 25.00 cc. the volumeter is consistent within 0.2 per cent which is also the accuracy of the result.

Disadvantages.—1. The initial cost of about two pounds of mercury. 2. The slight tendency of the mercury to remain in cracks and holes of some briquettes, although readily shaken back into the reservoir. 3. A slight difficulty in obtaining the reading for the first dozen determinations.

Advantages.—1. No 12-hour soaking in kerosene is necessary for dry briquettes. 2. There is no draining of briquettes after immersion. 3. No

¹ Received Feb. 17, 1921. Published by permission of the Director, U. S. Bureau of Mines.

draining of liquid is necessary. 4. It is direct reading. 5. It is very speedy and accurate. 6. No adjustment is necessary before each volume is taken, and, when adjustment is required, it is very quickly accomplished. 7. There is no adjusting of ground glass stoppers.

Existing Volumeters

Throughout the country several types of volumeters, employing diverse principles, are in use for quick measurement of the volumes of ceramic products. A brief consideration of the disadvantages of each of these types will make clear the need for an improved volumeter.

Seger Volumeter.¹—The Seger type of volumeter is the one recommended by the committee on standards of the American Ceramic Society for obtaining volumes of clay samples—plastic, dry, and fired. The only advantage which it possesses over the others is that it can handle a larger volume. The disadvantages have been summarized by Schurecht.² His criticisms are well-merited and apparent to anyone who has used this type of volumeter.

Pycnometer (Schurecht).—In order to overcome some of the objections, Schurecht used a true pycnometer method in which the weight of the briquette in air, the weight immersed in a liquid, and the weight of the liquid displaced, are used in determining its volume. This method involves two weighings for each volume, and a check-weighing of the pycnometer and liquid at frequent intervals.

In order to reduce the time of weighing, the balance is loaded so that the swing of the pointer represents exactly 0.1 gm. per scale division. This plan allows rapid determinations of the weights. For computing the volumes from the data thus obtained, a set of tables is used in which the values have been computed from laboratory data which depend upon the size of briquette and pycnometer used.

Shaw³ has discussed and summed up the disadvantages of the pycnometer method in which weighing is necessary.

¹ Iowa Geological Survey, *Annual Report*, 14, 115 (1903).

² Schurecht, *THIS JOURNAL*, 1, 556 (1918).

³ Shaw, *THIS JOURNAL*, 2, 487 (1919).

Direct Reading Pycnometer (Shaw).—Shaw illustrates a similar apparatus in the same paper which reads volumes directly by placing the briquette in a glass bottle and filling to a mark, removing the stopper and briquette, replacing the stopper and then refilling the bottle to the mark by means of a burette delivering through a tube in the stopper. The volume of liquid run from the burette into the bottle then represents the volume previously occupied by the briquette. The advantages listed by Shaw for his apparatus are: "(1) Speed; (2) simplicity; (3) low cost; (4) sufficient accuracy."

In the manipulation of the Shaw apparatus the briquette must be wiped so that there is no free liquid on the surface, and must be allowed to drain back into the bottle after removing until no free liquid remains on the surface, for two drops of water or three of kerosene are equal to 0.1 cc., and since the volume is to be determined to tenths of a cc., this amount could readily introduce an appreciable error. Obviously, this draining will take time. Any method in which the briquette is removed from a measured volume of liquid before the volume of the briquette is determined is bound to introduce this factor of draining. Again, the stopper must be replaced exactly as it was at first to insure the same internal volume, and lastly, the burette must be allowed to drain for at least three minutes in order to obtain an accurate reading.

Hubbard and Jackson Volumeter.—This volumeter is described by Hubbard and Jackson,¹ who give detailed results of tests upon different types of apparent-specific-gravity apparatus.

Goldbeck Volumeter.—In Hubbard and Jackson's article a description is also given of an apparatus in which the liquid displaced by the briquette is allowed to overflow into a beaker and is then weighed. This is, therefore, essentially an overflow type of volumeter in which weighings must be made, and the transfer of the liquid from one vessel to another is not an accurate method for fast work.

¹ *Proc. Am. Soc. Test. Mat.*, 16, 378-401 (1916).

Staley Apparatus.—Staley¹ has developed a volumeter which causes the rise in level of a liquid due to immersing the briquette in a reservoir, to be magnified by having the rise take place in a tube inclined slightly from the horizontal and attached to the reservoir. The above method has the following faults. The least variation in the angle of inclination of the reading tube will vitiate the results; the volumeter must be calibrated, and considerable care exercised in its manipulation; the zero point must be adjusted every time a volume is taken. Although the apparatus is very accurate, if handled properly, it is rather fragile and hard to keep set accurately.

Spurrier Volumeter.—Spurrier² describes a sensitive volumeter in which volumes are read directly by means of magnifying the rise in the level of a liquid by forcing the displaced volume of liquid into a capillary tube. The operation consists of filling a reservoir to a given level, placing the sample in the reservoir, and then forcing the displaced liquid into a capillary tube by means of lung pressure applied through a rubber tube attached to the top of the reservoir. This does not require any draining of the sample after placing it in the volumeter and the volume is read directly on the capillary tube.

Spurrier uses this volumeter for small volumes only; a correction must be made for capillarity and the readings must be made under practically constant temperature conditions. Also, in returning the liquid to its original level, considerable care must be exercised in order that the exact level be reached. He states that no claims are made for speed or convenience, although the instrument is exceedingly accurate and very neatly designed.

Overflow Type of Volumeter³ (Schurecht).—In this type the bar is placed in a cylinder or reservoir having an internal tube which discharges the liquid displaced by the briquette directly into a burette, where it is measured. This type has been in use

¹ U. S. Bur. Stands. Report on Construction and Tests of a Staley Volumeter, Verbal Request of The Committee on Standards of The American Ceramic Society, Feb. 5, 1919.

² Spurrier, *THIS JOURNAL*, 3, 400 (1920).

³ Schurecht, *THIS JOURNAL*, 3, 730 (1910).

at the U. S. Bureau of Mines stations at Columbus, Ohio, and Seattle, Wash., for some time.

The disadvantages of this method are as follows: When water is used, a hard, thin coating of dirt often forms upon the inside of the burette, causing slow drainage and the clinging of drops of water to the upper part of the tube. Any vibration of the burette to cause better draining is inadvisable because this would result in a further flow from the cylinder. The waiting, as a result, slows up the operation. The same briquette does not give the same volume, if dropped or lowered rapidly into the cylinder as is obtained if it is lowered slowly, due to little ripples flowing over the top of the tube. In rapid work the volume reading of the same briquette, when placed in different sets, varies as much as three-tenths of a cubic centimeter. The liquid, particularly water, is liable to cling to any dirt lodged upon the overflow tube, causing an error, which is particularly liable to happen with crumbly briquettes. Undoubtedly, if sufficient care and time are taken, the results may be made to check closely enough for the ordinary volumes needed in ceramic control work. These disadvantages apply in a lesser degree to the use of kerosene for measuring plastic volumes.

The advantages of this volumeter are: (1) Simplicity of construction and operation; (2) no glass stoppers are used; (3) no draining back of liquid from briquette to the volumeter is necessary; (4) if twelve to twenty-four volumeters are used, a large number of volumes may be determined rapidly.

Requisites of a satisfactory Volumeter

The requisites of a satisfactory volumeter are, briefly, the following: (1) The briquette should not be removed from the container in order to obtain its volume; (2) the volume should be obtainable by direct reading; (3) filling the container to a definite level or recharging for each determination should be avoided; (4) saturation of the briquette before immersion should be avoided; (5) the results should be consistent and accurate to 0.1 cc.

If a volumeter can meet these requirements, it will be unusually fast and accurate.

A New Mercury Volumeter

While making preliminary tests of clay samples collected in the course of a survey of the ceramic resources of the State of Washington, the writer found that the existing types of volumeters required too much time to operate. Since eighteen volume determinations for each of three hundred samples of clays burned to different temperatures were required, a volumeter was designed with the object of increased speed of operation. Mercury was adopted as the liquid for obtaining the volumes, mainly for the reason that it does not "wet" the briquettes, whether they are in the plastic, dry, or fired state. The mercury does, however, fill the holes and cracks, thereby giving correct bulk volumes. The volumeter has been tried out very carefully in actual work as well as in comparative tests and has proved satisfactory.

Principle of Operation.—The principle of the new mercury volumeter is somewhat akin to that of the apparatus used by Spurrier, although differing in the method of obtaining the zero point, and is an adaptation of the gas analysis apparatus known as a "nitrometer," which is used for determining the volume of nitric oxide liberated during the analysis of nitrates. The briquette is placed in a reservoir containing mercury, which is connected by a piece of rubber pressure-tubing to a burette¹ having an enlarged end to receive a one-hole stopper. The mercury stands ordinarily at zero. When a briquette is introduced, it causes a rise in level in both the reservoir and the burette. The burette is then lowered until the mercury has resumed its former level. This is accomplished by having the burette mounted upon a sliding frame which is actuated by means of a rack and pinion. The lowering of the burette adds more glass tubing to the circuit, which, of course, takes care of the displaced mercury. The volume is then read directly from the burette. The top of the mercury meniscus forms an excellent mirror upon which to see the reflection of the zero point.

Construction.—The construction of the volumeter is not difficult and all of the material is at hand in nearly every labora-

¹ The burette is a graduated tube from Schumann's specific gravity bottle and reads from 0 at bottom to 50 at top. Cost about \$3.50.

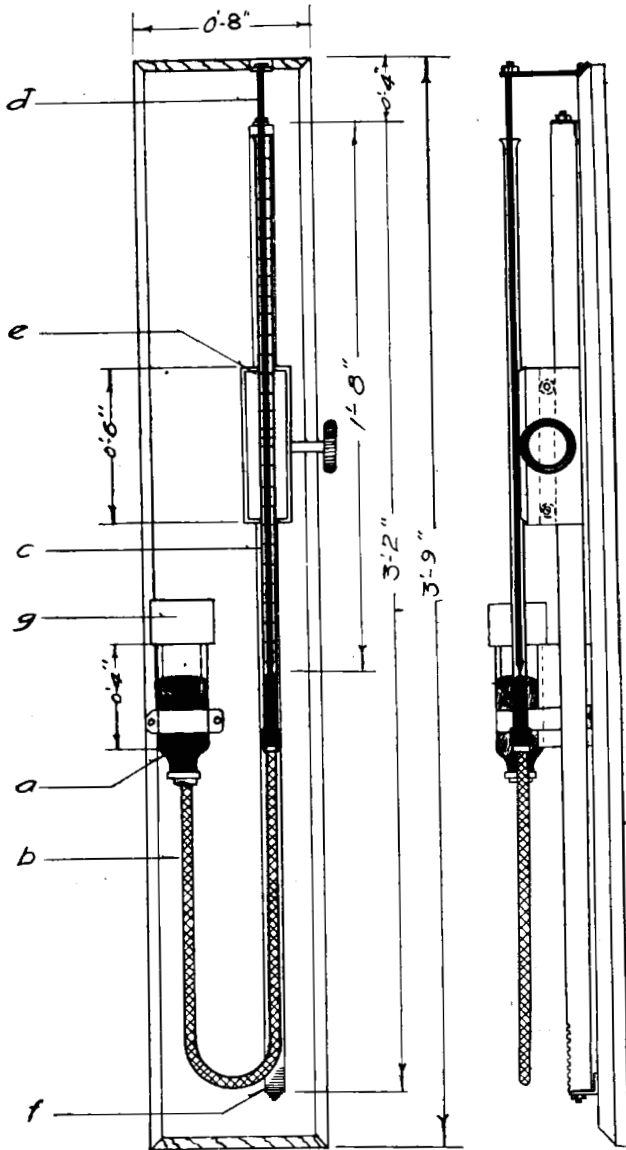

FIG. 1.

tory. The reservoir, "a" (Fig. 1), can be made from a tall, round or square bottle having a narrow neck. In this laboratory a reservoir made of glazed porcelain is being used. The diameter or width should be about $1\frac{3}{4}$ inches for standard dry test pieces. The bottom can be cut off by grinding on the edge of an emery wheel just above the seam between the bottom and sides. A rubber stopper is forced into the neck of the bottle and a 3-foot piece of rubber pressure-tubing, such as that used on suction apparatus, is attached by means of a short glass tube with a bulge at each end. The joint should be wired tightly and then waxed very securely. The other end of the tube is attached to burette "c" in a similar fashion. If a rack and pinion is to be used for raising and lowering the burette, the method shown in the drawing will be found very satisfactory.

In order to have a good, readable zero point, a pointed quarter-inch rod, "d," is bolted to the board by an iron brace and extends down inside the burette, ending at the zero point. This rod may be connected to one terminal of a bell circuit and the mercury made the other terminal, which will cause the bell to ring until the zero point is passed. However, with clean mercury, the end of the rod is reflected in the convex meniscus and the exact zero point is easily obtained.

Manipulation.—The manipulation is simple. First, after mounting solidly, the burette is raised until the lower end of the rod is exactly opposite the zero line on the burette. Then mercury is poured into the system until it touches the end of the rod, care being taken that the briquette holder is in place when the final adjustment for zero is made. The burette should then be run past this point several times in order to see that the mercury is running freely. Experience shows that on the first two or three trials one is apt to misjudge the point. However, when it has once been determined, there is no difficulty in duplicating it. The burette should always be raised in reaching the final adjustment in order to expose a clean and bright mercury surface.

The volumeter being ready for use, the briquette is placed in the holder, pushed under the mercury, and the burette then lowered until the point of the rod emerges from the mercury. The

setting is then readily obtained. The distance between the top of the mercury and the end of the rod is an indicator of the movement required for adjustment. Thus a difference of two-tenths of a cubic centimeter between the end of the rod and the top of the mercury requires about one centimeter movement of the burette. In regard to the setting of the zero point, this will have to be re-adjusted from time to time, either by adding a drop or two of mercury or by lowering or raising rod, "d." This is necessary after about every fifteen or twenty briquettes and may be readily checked by raising the burette to the zero point at fairly frequent intervals.

Tests of the New Volumeter

Mathematical Considerations.—The accuracy with which the volumes may be determined depends directly upon the ratio of the areas of reservoir and burette. Let us suppose that the area of the mercury surface in the reservoir is 16 sq. cm. and in the burette 1 sq. cm. Since area A times height H equals volume V , or,

$$\frac{V}{A} = H, \text{ then } \frac{V}{16 + 1} = H$$

Suppose that the volume V of the briquette is 25 cc. This volume is distributed throughout the system causing a rise of 25/17 or 1.47 cm. rise in each limb of the circuit. Hence, in a volumeter with the ratio of 16 to 1, the 25 cc. briquette would cause a rise of only 0.0587 cm. for each cc. of the briquette. With a reflection of the pointer, such as takes place in the mercury surface, it is possible to read to a much smaller length than 0.05 cm. However, let us use a volumeter with the ratio of 1 to 1. Then 25/2 or 12.5 cm. is the rise in each limb for the briquette. This is 0.5 cm. rise for each cc. of volume, or 0.05 cm. for each tenth cc. Extensive checking of the present instrument with a microscope-cathetometer showed unquestionably that the pointer may be adjusted with the naked eye to 0.003 cm. without fail. This corroborates observations by many physicists that the method of reflection reading of a point is extremely accurate.

These considerations must not be construed to mean that in reading the volume of a briquette with this mercury volumeter

one must estimate distances less than a tenth of a centimeter, for after the burette has been lowered or raised so that the mercury is at its original level, as when set at zero, *all* of the displaced volume of liquid is in the burette and the volume is read to tenths just as in the ordinary burette reading. But if in adjusting so that the reflection is just tipping the actual pointer, an error of

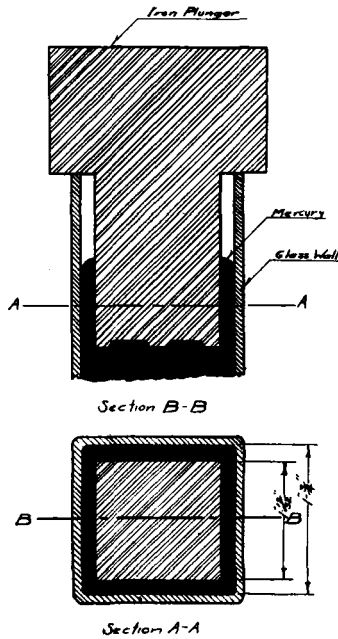

FIG. 2.

0.05 cm. is made, this will correspond to an actual error of 0.1 cc. in the burette volume.

In order to obtain the ratio of approximately one to one for the area of the mercury reservoir to the area of the burette, it is necessary to reduce the area of free surface of mercury in the reservoir, since the cross section of the burette is necessarily fixed. This reduction is accomplished by using a heavy metal plug or plunger which has an area about one sq. cm. less than the reservoir. It is set so that it extends below the surface of the mercury when set at zero. When a bar of clay is introduced, the heavy metal plun-

ger keeps it from floating, and also confines the mercury surface to that which is free between the sides of the reservoir and the sides of the plunger (see Fig. 2). The bottom of the plunger is grooved to allow free access of the mercury above the briquette.

The question of expansion of the rubber tube, due to greater pressure caused by the increased length of mercury column when a briquette is placed in the reservoir, was answered in the following manner.

The diameter of the tube was measured by means of the cathetometer at three different points: four inches below each end, and at the lower point. A briquette of 47.0 cc. was then placed in the volumeter and the exact volume determined. The diameters were then re-measured at the same points. A maximum increase in diameter of one-fortieth of a millimeter was found at the lowest point in the tube, which may be reasonably attributed to experimental error or to increased pressure. Such an expansion throughout the total length of the tube would introduce an error of 0.005 cc. in the reading. A volume of 50.0 cc. of mercury at 13.2 gm. per cc. would weigh 660 gm. which would be distributed over the internal area of the rubber tube, or 2.03 gm./sq. cm., which is an insignificant increase in pressure for even thin tubing.

Comparative Tests.—In testing out this volumeter five burned briquettes were measured. Dry, or when saturated with water, the volumes were exactly the same. Then the saturated volumes were taken in an overflow type of volumeter using every care possible to avoid errors. The results checked within less than 0.05 cc. Plastic volumes were checked in a similar manner.

Then water was substituted for the mercury in the new volumeter, and the volumes re-determined. The same values were obtained as before. This indicates that for this purpose the action of the mercury in surrounding a briquette is the same as that of water. Finally, the volumes were measured by means of a Schurecht pycnometer and the results checked those of the mercury volumeter almost exactly.

Following this same line of reasoning, one could substitute mercury for water or kerosene in the overflow type of volumeter, and thus remove some of the draining difficulties. However, the refilling of the reservoir and setting to zero would still be necessary.

Laboratory Tests.—As an independent check, two graduate fellows from the Department of Chemistry in the University of Washington were asked to use this volumeter in determining the volumes of 200, 100, 50, 20, and 10-gram weights. The volumes were unknown to the operators and independent determinations were run. The actual volumes were determined by taking the weights in air and immersed in water, correcting for the volume of the wire support, and thus determining their true volumes. This was done after the volumeter readings had been taken. The results follow.

Weight.....	200.00	100.00	50.00	20.00	10.00	Observer,
Reading.....	25.10	12.95	6.60	2.45	1.45	1
	25.10	12.95	6.50	2.45	1.45	1
	25.10	13.00	6.50	2.45	1.45	1
	25.15	13.00	6.55	2.45	1.45	2
	25.10	13.00	6.55	2.50	1.48	2
	25.10	13.00	6.50	2.45	1.45	3
	25.10	12.95	3
	25.10	13.00	3
	25.15	13.00	3
Mean.....	25.11	12.98	6.53	2.46	1.455	
Per cent variation....	0.1592	0.2311	1.07	1.625	0.344	
Exact vol.....	25.150	13.001	6.53	2.475	1.40	
Per cent error.....	0.1590	0.1540	0.00	0.601	3.930	

The above results indicate that the volumeter is very consistent, for the variations were less than two-tenths of one per cent, even with different operators, while measuring volumes comparable with those of test clay briquettes, and finally, that for the volumes greater than 10 cc. the error of the mercury volumeter is less than two-tenths of one per cent based upon the true volumes as determined by loss in weight when immersed in water.

Summary

Disadvantages.—The disadvantages may be summed up as follows: (1) the initial cost of about two pounds of mercury; (2) slight tendency of mercury to remain in small holes and cracks of some briquettes, although it is readily shaken back into the

reservoir, and (3) a slight difficulty in obtaining readings for the first dozen determinations.

The precautions to be taken are these: Make absolutely rigid and tight connections with rubber pressure-tubing; use clean mercury, and check zero point after every few volume readings.

To clean mercury, it is only necessary to press it through the mesh of a clean handkerchief. Dust and dirt will float to the top of the mercury in the reservoir and can be easily blown off by means of a rubber tube and the breath. Occasionally the burette should be wiped clean by means of a burette brush, removal of the mercury during this operation not being necessary.

Advantages.—The advantages of this volumeter are as follows: (1) No twelve-hour soaking in kerosene is necessary for dry briquettes; (2) no draining of briquettes after immersion; (3) no draining of liquid; (4) it is direct reading; (5) it is very speedy and accurate; (6) no adjustment is necessary for every volume taken and when adjustment is required it is very quickly accomplished; (7) there is no adjusting of ground glass stoppers.

The writer wishes to acknowledge his indebtedness to Professor Hewitt Wilson, head of the Ceramics Department of the University of Washington and ceramist of the U. S. Bureau of Mines, for his interest and many helpful suggestions during the development of the volumeter, and also to Dr. H. V. Tartar, who kindly placed the physical chemistry laboratory of the University of Washington at the disposal of the writer for testing the volumeter.

COLLEGE OF MINES, UNIVERSITY OF WASHINGTON
SEATTLE, AND NORTHWEST EXPERIMENT STATION
U. S. BUREAU OF MINES