



Sustainable sewage sludge management fostering phosphorus recovery and energy efficiency



Project supported by the European Commission within the Seventh
Framework Programme Grant agreement No. 308645



Revision track

Author	Content	Date of issue
Christian Remy	v1	11.09.2015

Deliverable D 9.2

Life Cycle Assessment of selected processes for P recovery
from sewage sludge, sludge liquor, or ash

Work package	WP09: Comparative Life Cycle Assessment of treatment-recovery paths
Deliverable number	D 9.2
Deliverable title	Life Cycle Assessment of selected processes for P recovery from sewage sludge, sludge liquor, or ash
Due date	Month 30
Actual submission date	11.09.2015
Start date of project	01.09.2012
Participants (Partner short names)	KWB (editor)
Authors in alphabetic order	Paul Jossa, Christian Remy
Contact for queries	Christian Remy Cicerostr. 24, D-10709 Berlin Phone: +49 30 536 53 808 Email: christian.remy@kompetenz-wasser.de
Dissemination level: (P ublic, R estricted to other P rogrammes P articipants, R estricted to a group specified by the consortium, C onfidential- only for members of the consortium)	PU
Deliverable Status:	Version 1

Table of content

1	Introduction	1
2	Basics of Life Cycle Assessment and literature review	5
2.1	LCA framework	5
2.2	Literature review of LCA studies of P recovery	6
3	Goal and scope definition	7
3.1	Goal and target group	7
3.2	Function and functional unit	7
3.3	Reference flow: mixed raw sludge	8
3.4	System boundaries	9
3.5	Scenarios for P recovery.....	10
3.5.1	Ref_EBPR and Ref_ChemP (reference scenarios).....	12
3.5.2	Sludge precipitation (Airprex™)	13
3.5.3	Liquor precipitation 1 (Pearl®).....	14
3.5.4	Liquor precipitation 2 (Struvia™)	16
3.5.5	Sludge leaching 1 (Gifhorn)	17
3.5.6	Sludge leaching 2 (Stuttgart).....	18
3.5.7	Sludge or ash metallurgic (Mephrec®).....	19
3.5.8	Ash leaching 1 (Leachphos)	20
3.5.9	Ash leaching 2 (Ecophos).....	21
3.5.10	Ash thermo-chemical (Ash Dec)	22
3.6	Data quality.....	23
3.7	Selection of indicators for LCA impact assessment.....	24
3.8	Normalisation	26
3.9	Sensitivity analysis	26
4	Life Cycle Inventory (input data)	28
4.1	Reference system	28
4.1.1	Digester and CHP plant.....	28
4.1.2	Dewatering in centrifuge	29
4.1.3	Return load treatment in mainstream WWTP	29
4.1.4	Mono-incineration and ash disposal.....	30
4.2	P recovery processes	31

4.2.1	P recovery from digested sludge or liquor	31
4.2.2	P recovery processes from dried sludge or ash.....	33
4.2.3	Quality of recycled P products.....	36
4.3	Background processes	36
4.3.1	Energy, chemicals, materials, transport	36
4.3.2	Credits for substituted products.....	38
5	Life Cycle Impact Assessment	39
5.1	Cumulative energy demand	39
5.2	Global warming potential	43
5.3	Metal depletion potential.....	46
5.4	Terrestrial acidification potential.....	46
5.5	Eutrophication (freshwater and marine).....	47
5.6	Ecotoxicity (freshwater)	48
5.7	Human Toxicity.....	50
5.8	Normalisation	52
5.9	Sensitivity analysis	54
5.9.1	Alternative disposal routes for combining energy and P recovery.....	54
5.9.2	Alternative indicators for human and ecotoxicity.....	59
5.9.3	P content of liquor	61
5.9.4	Increase in dewatering by sludge precipitation	62
6	Interpretation and conclusions.....	63
6.1	Environmental profiles of P recovery processes and pathways.....	63
6.2	Limitations of this study.....	66
6.3	Outlook.....	68
7	References.....	69
8	Annex.....	72
8.1	Umberto® model	72
8.2	Infrastructure data	73
8.3	Aggregated data of Life Cycle Inventory.....	74
8.4	Additional results of Life Cycle Impact Assessment.....	76

List of figures

Figure 1-1: Pathways for P recovery from wastewater sludge and respective relative potential for P recovery related to total load in wastewater.....	2
Figure 2-1: General framework of LCA for water treatment processes.....	5
Figure 3-1: System boundaries of LCA for P recovery processes.....	10
Figure 3-2: Reference scenarios Ref_EBPR and Ref_ChemP.....	13
Figure 3-3: Process scheme of Airprex™ process.....	14
Figure 3-4: Process scheme of Pearl® process.....	15
Figure 3-5: Process scheme of Struvia™ process.....	16
Figure 3-6: Process scheme of Gifhorn process.....	17
Figure 3-7: Process scheme of Stuttgart process.....	18
Figure 3-8: Process scheme of Mephrec® process.....	19
Figure 3-9: Process scheme of LeachPhos process.....	21
Figure 3-10: Process scheme of Ecophos process.....	22
Figure 3-11: Process scheme of Ashdec process.....	23
Figure 4-1: Reference system.....	28
Figure 5-1: Total cumulative energy demand (fossil) of P recovery from sludge or liquor.....	39
Figure 5-2: Total cumulative energy demand (fossil) of P recovery from dried sludge or ash.....	40
Figure 5-3: Total cumulative energy demand (fossil) related to P recovery potential.....	41
Figure 5-4: Cumulative energy demand (fossil) per kg P related to P recovery potential.....	42
Figure 5-5: Total global warming potential (100a) for P recovery from sludge or liquor.....	43
Figure 5-6: Total global warming potential (100a) for P recovery from dried sludge or ash.....	44
Figure 5-7: Total global warming potential (100a) related to P recovery potential.....	45
Figure 5-8: Global warming potential (100a) per kg P related to P recovery potential.....	45
Figure 5-9: Total metal depletion potential of P recovery from sludge or liquor.....	46
Figure 5-10: Total metal depletion potential of P recovery from dried sludge or ash.....	47
Figure 5-11: Total freshwater eutrophication potential for P recovery from sludge or liquor.....	48
Figure 5-12: Total freshwater eutrophication potential for P recovery from dried sludge or ash.....	48
Figure 5-13: Total ecotoxicity (freshwater) of P recovery from sludge or liquor.....	49
Figure 5-14: Total ecotoxicity (freshwater) of P recovery from dried sludge or ash.....	49
Figure 5-15: Total ecotoxicity (freshwater) related to P recovery potential.....	50
Figure 5-16: Total human toxicity of P recovery from sludge or liquor.....	51
Figure 5-17: Total human toxicity of P recovery from dried sludge or ash.....	51
Figure 5-18: Total human toxicity related to P recovery potential.....	52
Figure 5-19: Normalised scores of all P recovery scenarios.....	53
Figure 5-20: Normalised scores of all P recovery scenarios (human and ecotoxicity excluded).....	53

Figure 5-21: Fossil energy balance of mono-incineration and co-incineration for original sludge from BAT facility (left) and P-REX sludge (right).....	55
Figure 5-22: Total cumulative energy demand (fossil) of selected scenarios assuming co-incineration or application in agriculture.....	56
Figure 5-23: Total global warming potential (100a) of selected scenarios assuming co-incineration or application in agriculture	57
Figure 5-24: Total ecotoxicity (freshwater) of selected scenarios assuming co-incineration or application in agriculture	58
Figure 5-25: Total human toxicity of selected scenarios assuming co-incineration or application in agriculture.....	58
Figure 5-26: Freshwater aquatic ecotoxicity potential (inf) for P recovery from sludge or liquor.....	59
Figure 5-27: Freshwater aquatic ecotoxicity potential (inf) for P recovery from dried sludge or ash.....	60
Figure 5-28: Human toxicity potential (inf) for P recovery from sludge or liquor	60
Figure 5-29: Human toxicity potential (inf) for P recovery from dried sludge or ash	61
Figure 5-30: Cumulative energy demand (fossil) per kg P for sludge and liquor precipitation depending on dissolved PO ₄ -P concentration in sludge.....	62
Figure 5-31: Cumulative energy demand (fossil) of sludge precipitation depending on TS increase in sludge dewatering	62
Figure 8-1: Reference scenario in Umberto NXT LCA	72
Figure 8-2: Total cumulative energy demand (nuclear) of P recovery from sludge or liquor.....	76
Figure 8-3: Total cumulative energy demand (nuclear) of P recovery from dried sludge or ash.....	76
Figure 8-4: Total terrestrial acidification potential (100a) for P recovery from sludge or liquor.....	77
Figure 8-5: Total terrestrial acidification potential (100a) for P recovery from dried sludge or ash.....	77
Figure 8-6: Total marine eutrophication potential for P recovery from sludge or liquor	78
Figure 8-7: Total marine eutrophication potential for P recovery from dried sludge or ash.....	78

List of tables

Table 1-1: Technologies for P recovery assessed in this LCA study.....	3
Table 3-1: Composition of reference flow (mixed raw sludge).....	8
Table 3-2: List of LCA scenarios.....	11
Table 3-3: Data quality of input data	24
Table 3-4: Indicators for impact assessment	25
Table 3-5: Normalization data for impact indicators	26
Table 4-1: Composition of sludge liquor in reference system	29
Table 4-2: Composition of ash in reference system	30
Table 4-3: Inventory of P recovery processes from sludge and liquor	33
Table 4-4: Inventory of P recovery processes from dried sludge and ash	35

Table 4-5: Heavy metal content of P products	36
Table 4-6: Ecoinvent datasets for background processes	37
Table 4-7: Ecoinvent datasets for substitution of products and by-products	38
Table 6-1: Environmental impacts of P recovery from sludge, liquor, or ash in relation to a reference model of sludge treatment and disposal in mono-incineraion for a 1 Mio pe WWTP	63
Table 8-1: Infrastructure data for sludge/liquor processes.....	73
Table 8-2: Infrastructure data for processes for dried sludge or ash.....	73
Table 8-3: Selected annual data of Life Cycle Inventory for P recovery from sludge or liquor.....	74
Table 8-4: Selected annual data of Life Cycle Inventory for P recovery from ash	75

List of abbreviations

BAT	-	Best available technology
CED	-	Cumulative energy demand
ChemP	-	Chemical phosphorus removal
CHP	-	Combined heat and power
COD	-	Chemical oxygen demand
CSTR	-	Continuously stirred tank reactor
DS	-	Dry solids
EBPR	-	Enhanced biological phosphorus removal
ETP	-	Ecotoxicity potential
FEP	-	Freshwater eutrophication potential
GHG	-	Greenhouse gas
GWP	-	Global warming potential
HRT	-	Hydraulic retention time
HTP	-	Human toxicity potential
LCA	-	Life Cycle Assessment
MDP	-	Metal depletion potential
MEP	-	Marine eutrophication potential
MSWI	-	Municipal solid waste incineration
N	-	Nitrogen
ORC	-	Organic Rankine Cycle
P	-	Phosphorus
TAP	-	Terrestrial acidification potential
TS	-	Total solids
VS	-	Volatile solids
WWTP	-	Wastewater Treatment Plant

Abstract

The recovery of phosphorus (P) from sewage sludge, sludge liquor, or ash from mono-incineration can be realized with different processes which have been developed, tested or already realized in full-scale in recent years. However, these pathways and processes differ in their amount of P that can be recovered in relation to the total P content in sludge, in the quality of the recovered P product, and in their efforts in energy, chemicals, fuels, and infrastructure required for P recovery. This study analyses selected processes for P recovery from sludge, liquor, or ash in their potential environmental impacts, following the method of Life Cycle Assessment (LCA, ISO 14040/44). Based on available process data from technology providers and end users, these processes are implemented in a hypothetical reference system for sludge digestion, dewatering and disposal in mono-incineration, including potential side-effects on mainstream wastewater treatment with the return load from sludge dewatering. Recovered products (e.g. P or N fertilizer, electricity, district heating) are accounted as credits for substituting equivalent industrial products. Depending on the maturity of the investigated process, collected process data of process efficiency, product quality, and energy and material demand originates from full-scale plants, pilot trials, or prospective modeling (status in 2014). This data is validated with the technology providers, transferred to the reference system and evaluated with a set of environmental indicators for energy demand, global warming, acidification, abiotic resource depletion, eutrophication, and human and ecotoxicity.

Results show that pathways and processes for P recovery differ heavily in their amount of recovered P, but also in energy and related environmental impacts (e.g. greenhouse gas emissions). As direct struvite precipitation in sludge or liquor relies on the dissolved amount of P in digested sludge, these processes are only applicable in wastewater treatment plants with biological P removal. Here, they can recover 4-18% of total P in sludge with a relatively low effort in energy and chemicals, reducing return load to the mainstream process and eventually improving sludge dewaterability in case of direct precipitation in sludge. Acidic leaching of P from digested sludge can yield up to 48% of P for recovery, but requires a significant amount of chemicals for control of pH (leaching and precipitation) and for minimizing heavy metal transfer into the product. The quality of products from sludge and liquor is good with low content on heavy metals, leading to a low potential toxicity for humans and ecosystems. Leaching of mono-incineration ash with sulphuric acid yields 70% P with moderate chemical demand, but the leached ash and co-precipitated materials have to be disposed, and the product contains some heavy metals. Complete digestion of ash in phosphoric acid and multi-stage cleaning with ion exchangers yields high recovery of 97% P in a high-quality product (H_3PO_4) and several co-products, having an overall low environmental impact. Thermo-chemical treatment of ash can recover up to 98% P with moderate energy input in case of integration into an existing mono-incineration facility, but the product still contains high amounts of selected heavy metals (Cu, Zn). Metallurgic treatment of dried sludge or ash can also recover up to 81% of P, but the process has still to be tested in continuous pilot trials to validate product quality, energy demand, and energy recovery options.

Sensitivity analysis shows that other pathways of sludge disposal (e.g. co-incineration combined with upstream P extraction, direct application in agriculture) may also be reasonable from an environmental point of view depending on local boundary conditions and political targets. In general, the use of life-cycle based tools is strongly recommended to evaluate and select suitable strategies for regional or national concepts of P recovery from sewage sludge.

1 Introduction

Phosphorus (P) is an essential resource for plants, animals and human life with limited amounts of economically exploitable mineral reserves on a global scale, which are concentrated in a small number of countries worldwide (USGS 2015). Due to growing demand for P for agriculture and industry and arising economical and geopolitical aspects of supply security, the recycling of P from suitable waste flows in the society is another alternative to ensure availability of P for food production and complement the limited supply from fossil P rock. Within the European Union (EU), P rock has been listed as “critical raw material” in 2014 which will foster the uptake of P recycling strategies in the near future (EC 2014).

A significant proportion of P used for food production is contained in municipal wastewater and ends up in the sewage sludge. Hence, the recycling of P from municipal sewage sludge to agriculture has been realized for decades with the agricultural disposal of this sludge onto farmlands. However, recent years have seen a reduction of this recycling route in many EU countries due to concerns about inorganic and organic pollutants found in the sludge and also due to indications of limited plant availability of P in sewage sludge depending on its Fe content (Römer 2006). Moving towards thermal disposal of sewage sludge in incineration plants (either as mono-incineration in dedicated facilities for sludge disposal, or as co-incineration in power plants, municipal waste incineration plants or cement kilns), the direct recycling of P from sewage sludge into agriculture is no longer feasible with the residual ash from incineration.

To overcome this drawback of limited P recycling with sludge incineration and close the P management cycle again, different pathways and processes of P recovery from sewage sludge or incineration ash have been developed in recent years (Petzet and Cornel 2011; Egle et al. 2014). From the total P load entering a wastewater treatment plant (WWTP) with dedicated P removal, >95% of the P load can be found in the mixed sludge from primary sedimentation and the activated sludge process. Assuming an on-site digestion process for sludge stabilisation and recovery of energy in the form of biogas as best-available technology (BAT), P recovery can be implemented at dedicated points of the following sludge treatment and disposal route. In general, three major routes for P recovery processes can be differentiated by their point of implementation (Figure 1-1):

- a) digested sludge as input
- b) dewatering liquor as input
- c) incineration ash as input

Due to process limitations in efficiency, these pathways differ in their total amount of P that can be recovered from sludge. P recovery in digested sludge or liquor is limited to the amount of soluble $\text{PO}_4\text{-P}$, which is in the range of 5-20% of total P load in WWTP sludge depending on the type of P removal process in the mainstream. For WWTPs using mainly chemical P (ChemP) removal via addition of Fe or Al salts, dissolved P concentration is usually low (<50 mg/L $\text{PO}_4\text{-P}$) in the liquor. For WWTPs applying enhanced biological P removal (EBPR or BioP), dissolved P concentration is typically higher (> 50 mg/L $\text{PO}_4\text{-P}$, up to 300-400 mg/L $\text{PO}_4\text{-P}$) which enables

higher recovery rates. For both type of sludges, P content of the solid phase can be substantially mobilized into the liquid phase by acidic leaching ($\text{pH} < 5$), so that total P recovery rates of up to 50% seem feasible in both pathways with reasonable acid demand.

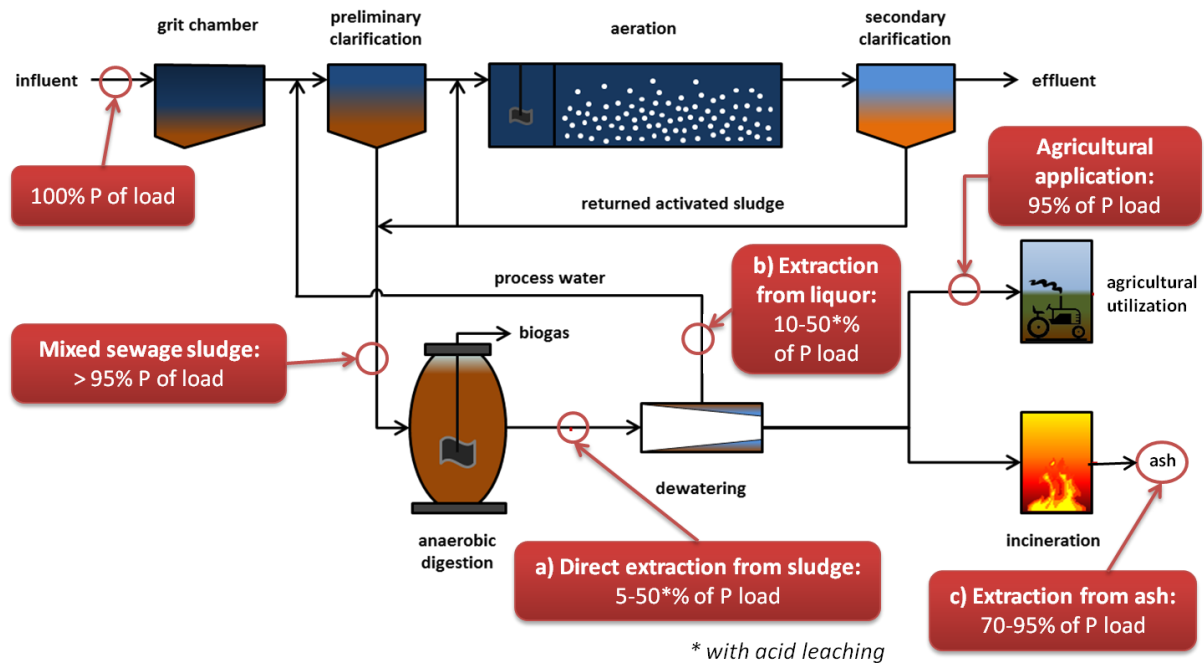

Figure 1-1: Pathways for P recovery from wastewater sludge and respective relative potential for P recovery related to total load in wastewater

If dewatered sludge is incinerated, the entire P load of the sludge ends up in the incineration ashes. In case of mono-incineration, P content of these ashes is typically 5-10% P (if not diluted by other inputs). Various options of P extraction or further processing of ash are possible with different efficiencies, so that final recovery rates of 70-95% of P load can be realized with P recovery from mono-incineration ashes. Ashes of co-incineration are usually diluted by inorganic content of other inputs, so that low P content ($< 2\%$) does not enable an efficient recovery or extraction from these raw materials.

Besides their variation in P recovery ratios, pathways and processes also differ in their amount of resources required for operation (e.g. electricity, chemicals, fuels, infrastructure), in their potential side-effects on upstream or downstream processes of sludge treatment and disposal, and in their quality of the P product in terms of heavy metal content. All these aspects affect resource demand and emissions associated with P recovery from sewage sludge, so that the environmental profile of the different secondary P products is expected to show large variations. However, for a comprehensive planning of future P recycling strategies on a regional, national, or EU level, tangible information about the environmental impacts and benefits of P recovery routes is essential to promote sustainable practices and support further development and implementation of those processes and pathways with lowest environmental impacts.

Consequently, the EU research project P-REX (FP7 #308645, www.p-rex.eu) assesses promising processes and pathways from sewage sludge, liquor or ash in their potential environmental impacts, following the holistic methodology of Life Cycle Assessment (LCA). This report presents the outcomes of a comparative LCA which targets the following questions:

- What are the environmental impacts associated with P recovery from sewage sludge, liquor or ash over the full life cycle?
- What are potential advantages and potentials for optimisation of existing technologies and processes with regards to their environmental profile?
- What data needs can be identified for future studies in this field to promote promising routes of P recovery and recycling?

Within the P-REX consortium, it was decided to include a selection of P recovery processes in the LCA which are applied in full-scale or large pilot installations, so that LCA input data can be mainly based on primary data from existing plants (Table 1-1). This should ensure validity and representativeness of the LCA results and enable a fair comparison between the processes.

Table 1-1: Technologies for P recovery assessed in this LCA study

Technology	Pathway	Suitable sludge	Plant	Scale
Airprex™	Sludge precipitation	<u>EBPR</u>	M'gladbach (GER)	Full-scale
Pearl®	Liquor precipitation	<u>EBPR</u>	Hillsboro (US)	Full-scale
Struvia™	Liquor precipitation	<u>EBPR</u>	Brussels (BE)	Large pilot
Gifhorn	Sludge leaching	<u>EBPR/ChemP</u>	Gifhorn (GER)	Full-scale
Stuttgart	Sludge leaching	<u>EBPR/ChemP</u>	Offenburg (GER)	Large pilot
Mephrec®	Sludge metallurgic	<u>EBPR/ChemP</u>	-	Model
Mephrec®	Ash metallurgic	<u>EBPR/ChemP</u>	-	Model
Leachphos	Ash leaching	<u>EBPR/ChemP</u>	Basel (CH)	Large pilot
Ecophos	Ash leaching	<u>EBPR/ChemP</u>	Bulgaria	Full-scale planning
Ash Dec	Ash thermo-chemical	<u>EBPR/ChemP</u>	Weimar (GER)	Pilot/model

underlined: assessed option in this LCA

In addition, all process data should be transferred from the existing sites to a hypothetical sludge line of a large-scale reference WWTP, treating the wastewater sludge of 1 Mio. population equivalents (pe). However, not all processes could be demonstrated in full-scale or large pilot plants during the duration of P-REX, so that some processes (especially those based on ash treatment) are still based on model data or qualified assumptions. Internal plausibility checks and cross-validation of input data between technologies are included to maintain a fair comparison and provide valid conclusions. Data quality of the LCA is critically discussed in this report, and it should definitely be taken into account when interpreting the outcomes of this comparative LCA.

This report consists of 6 chapters:

- **Chapter 2** gives a short overview about LCA methodology and existing LCA studies in the field of P recovery from wastewater sludge
- **Chapter 3** provides all definitions regarding goal and scope of the LCA (e.g. system boundaries, scenarios, co-products, data quality)
- **Chapter 4** summarizes all input data for the LCA and describes the modelling approach
- **Chapter 5** presents the results of Life Cycle Impact Assessment for all environmental indicators, including normalisation and sensitivity analysis
- **Chapter 6** discusses major outcomes of this LCA and gives a critical summary of the limitations of this LCA study together with the main conclusions.

2 Basics of Life Cycle Assessment and literature review

2.1 LCA framework

For assessing technical processes and systems in their potential environmental impacts, the method of Life Cycle Assessment (LCA) has been developed and applied widely within research and industry (Klöpffer and Grahl 2009), also in the field of wastewater and sludge treatment (Corominas et al. 2013). Taking the life-cycle perspective into account, this method quantifies potential environmental impacts of a defined system based on quantitative information on resource needs and emissions of all relevant processes which are affected by the system under study ("foreground system"). Thus, both direct effects on-site and indirect effects upstream (e.g. electricity production) and downstream (e.g. waste disposal) of the core process are assessed in their environmental impacts (Figure 2-1). Building on substance flow models of the foreground system and database information for the background system, all relevant inputs and outputs across the system boundary from or into the environment are quantified and summarized. This inventory information is then evaluated with a defined set of environmental indicators, relating to specific areas of environmental concern (e.g. anthropogenic climate change, acidification, or ecotoxicity).

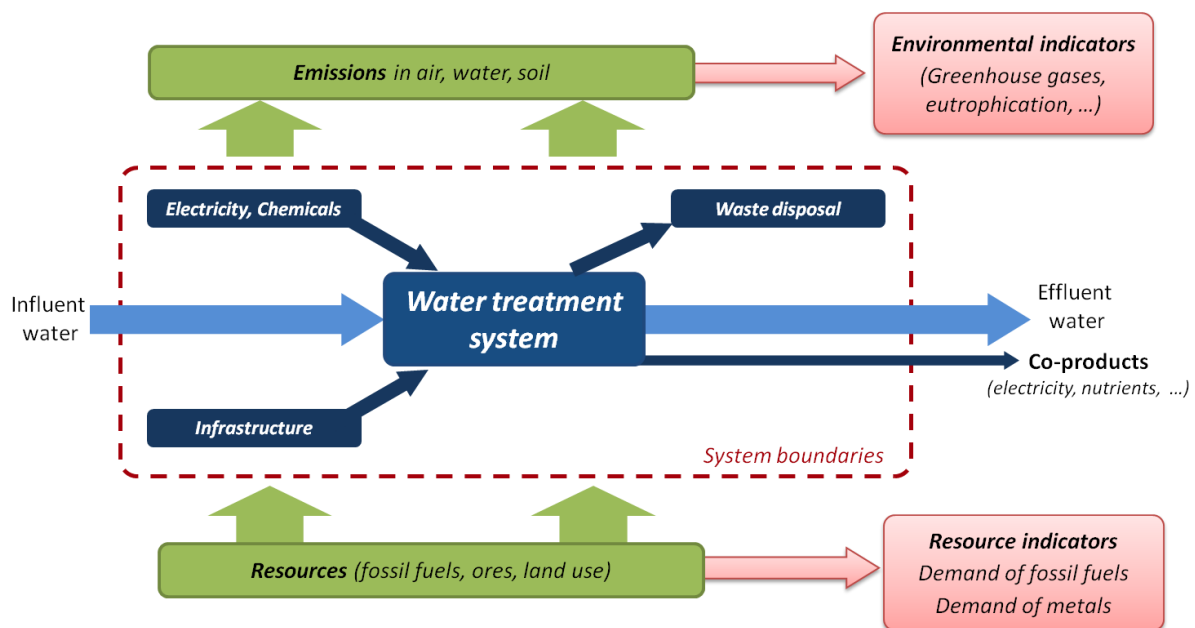

Figure 2-1: General framework of LCA for water treatment processes

The general framework of an LCA is defined in the ISO standards 14040/44 (ISO 14040 2006; ISO 14044 2006). The following steps are part of the LCA:

- 1) Definition of goal and scope (e.g. system functions, system boundaries, scenarios, data quality)
- 2) Life Cycle Inventory (collection of input data for foreground and background processes)
- 3) Life Cycle Impact Assessment (calculation of environmental indicators, normalisation and optional grouping/weighting)

- 4) Interpretation (e.g. discussing of results with regards to limitations of the study, sensitivity analysis)

The entire procedure of LCA is planned to be iterative, so that previous definitions of goal/scope or collected data can be modified/adjusted in the course of the study to improve the quality of the LCA towards the defined goals.

2.2 Literature review of LCA studies of P recovery

Previous LCA studies have analysed P recovery from wastewater sludge, using a variety of different model assumptions and reference systems. The most important studies in this field in recent years include the following:

- **K. Linderholm et al** analyse different options for P recycling to agricultural land, including direct application of sewage sludge, struvite from PEARL® process, and processed ash from mono-incineration in the ASH DEC process (Linderholm et al. 2012). They find that direct application of sludge on farmland was associated with lowest environmental impacts, especially for energy demand and greenhouse gas emissions.
- **Fehrenbach et al.** discuss 5 selected processes for P recovery in their environmental impacts, using an LCA approach (Fehrenbach and Reinhardt 2011). Based on a defined weighting of indicators, they find that variations in product quality (Cd, Pb content) have the most important impact on the environmental profile. In a single-indicator aggregation, they identify the PASCH and P-ROC processes as optimum with the lowest overall environmental impact.
- **Egle et al.** describe an assessment of 20 different technologies for P recovery, based on a selection from a list of 46 technologies found in the literature (Egle et al. 2014). They include environmental criteria based on LCA, but also economic and technical aspects. In the LCA, they found major differences of the investigated technologies and pathways of P recovery. Overall, ash-based recovery processes are recommended due to their high product quality, high P recovery ratio, and relatively moderate efforts in energy and chemical demand.

Most parts of these studies are based on LCA input data collected from literature or small-scale trials in laboratory setups, thus relating to site-specific data and comparing different scales of the processes (full-scale, pilot, lab data). Sufficient data quality for a comparative LCA study could not always be provided or is not documented correctly. For the P-REX LCA, the goal is to rely on full-scale or large pilot data as much as possible and transfer it to a reference WWTP model, working in close collaboration with technology providers and project partners. In addition, intensive internal validation and cross-check of transferred data should maximize validity and representativeness of the LCA outcomes, so that they are based on realistic input data validated by technology experts.

3 Goal and scope definition

3.1 Goal and target group

The goal of this LCA is to assess selected processes for P recovery from municipal sewage sludge, liquor, or incineration ash in their environmental impacts, taking into account all relevant side-effects on the sludge treatment or the mainstream WWTP. The assessment is based on a reference system, which is defined as the sludge line treating the mixed sludge of a WWTP with 1 Mio pe and disposing it in mono-incineration. This LCA should characterize all processes in their environmental impacts for a comparative analysis of benefits and drawbacks, revealing potentials for further optimisation of the individual processes.

The target group of this study consists mainly of policy-makers and regulators dealing with P recovery issues, technology providers of P recovery processes, and WWTP operators or engineers willing to engage in the P recovery sector. In addition, scientific and institutional experts may also benefit from this study to get informed about the environmental profile of P recovery options and future potentials for research and development in this sector.

3.2 Function and functional unit

The function of the system under study relates to the treatment and disposal of mixed sludge of a typical large-scale WWTP in mono-incineration. Consequently, the primary system function can be formulated as “system for treatment and thermal disposal of mixed sludge, starting from raw sludge after thickening until final disposal in mono-incineration”. P recovery from sewage sludge is a secondary function of the system which is introduced by the implementation of dedicated processes for producing a P product.

Based on the system functions, the following functional units can be defined:

- Following the “**system change**” **perspective**, all additional impacts of P recovery scenarios (i.e. changes between reference system and P recovery scenario) are allocated to the process of P recovery, assuming an annual time horizon. The respective functional unit is “per annual operation of a sludge line for 1 Mio pe WWTP” or [a⁻¹].
- Following the “**product**” **perspective**, the additional impacts between reference system and scenario with P recovery can also be related to the total amount of recovered P product. The respective functional unit is “per kg of recovered P product” or [kg P⁻¹].

The former perspective of system change allows recognizing the different P recovery ratios in the LCA results and thus enables a comparison of different processes and pathways with a systems view, showing the total amount of recovered P and the related total environmental impact of the system. In contrast, the latter perspective of P product compares the different secondary P products on an individual basis, showing the environmental profile of each product in relation to delivering a defined amount of phosphorus (= 1 kg P). Both perspectives can be useful in discussing future strategies of P recovery from sewage sludge, so the LCA results are shown here for both functional units.

3.3 Reference flow: mixed raw sludge

The reference flow is defined as the annual input raw sludge that originates from the wastewater treatment process of a large scale WWTP, treating the wastewater of 1 Mio pe. Sludge quantity and quality are defined based on previous LCA studies of KWB, representing an average composition of mixed sludge for German large-scale WWTPs (Table 3-1). Input sludge composition was discussed and validated within the P-REX consortium. As P removal in mainstream WWTP has a decisive impact on some pathways for P recovery, two sludge qualities are defined for reference: the first option represents sludge from chemical P removal with high Fe content, whereas the second option relates to EBPR plants with lower Fe content.

Table 3-1: Composition of reference flow (mixed raw sludge)

Parameter	Unit	Mixed raw sludge	
		ChemP	EBPR
Volume	m^3/a	418'800	418'800
Dry solids (DS)	%	5	5
	t/a	20940	20940
Volatile solids	% of DS	72	75
COD	$g/kg DS$	1'008	1'050
N	$g/kg DS$	50	50
P	$g/kg DS$	25	25
PO ₄ -P dissolved	mg/L	10	200
Fe	$g/kg DS$	40	12
Mg	$mg/kg DS$	4	4
Cd	$mg/kg DS$	0.6	0.6
Cu	$mg/kg DS$	270	270
Cr	$mg/kg DS$	40	40
Ni	$mg/kg DS$	15	15
Pb	$mg/kg DS$	32	32
Hg	$mg/kg DS$	0.5	0.5
Zn	$mg/kg DS$	630	630

Defined by P-REX consortium, heavy metal concentration based on UBA monitoring of mono-incineration ashes (Krüger and Adam 2014)

Dry matter content of mixed sludge is defined as 5% dry solids (DS), representing a typical mixed sludge after thickening and before digestion. Total sludge volume is calculated from total DS load, assuming 57.4 g DS/(pe*d) as mean sludge production for both systems. Volatile solids (VS) content is higher for EBPR sludge due to higher Fe content in the ChemP sludge, and chemical oxygen demand (COD) is recalculated from VS with a constant factor (1.4 g COD/g VS (ATV 2000)). Nutrient content of both sludges is comparable for nitrogen and phosphorus, so that both sludges contain the same total amount of P. P concentration in sludge, liquor and incineration ash has a major impact on process efficiencies, as it defines the maximum potential for P recovery. P concentration in the sludge (2.5% of DS) is defined based on monitoring of incineration ashes in Germany (Krüger and Adam 2014), calculating back to reach 9.5% (ChemP) to 10.7% (EBPR) of total P in ash. This represents the upper range of P content in incineration ashes of Germany, thus assuming favorable conditions for P recovery in sludge and ash with high P content in this study.

A major difference between ChemP and EBPR sludge relates to the dissolved concentration of PO₄-P in the sludge water, which is assumed to 10 mg/L PO₄-P for ChemP sludge and 200 mg/L PO₄-P for EBPR sludge based on typical estimates of project partners. In case of EBPR sludge, P recovery options are heavily depending on dissolved P concentration, so that this assumption is checked in sensitivity analysis by varying P concentration between 100-300 mg/L PO₄-P.

Heavy metal content of the raw mixed sludge is back-calculated from monitoring data of incineration ashes in Germany (Krüger and Adam 2014), so that ash quality in the LCA model in terms of heavy metal content represents weighted average of mono-incineration ashes in Germany.

3.4 System boundaries

The system boundaries of this LCA include all processes that are related to sludge treatment and disposal in a state-of-the-art WWTP in Germany. In particular, this relates to the following processes (Figure 3-1):

- Sludge digestion and biogas valorisation in combined heat and power (CHP) plant
- Sludge dewatering in centrifuges
- Recycling of sludge liquor to the mainstream WWTP process, represented by a simplified model for electricity demand in the mainstream
- Transport of dewatered sludge to mono-incineration
- Mono-incineration
- Disposal of ash in underground deposit
- All major background processes required for operation, i.e. production of electricity, chemicals, and fuels
- Additional infrastructure of the P recovery process, excluding existing infrastructure of the reference system
- Substitution of mineral fertilizer production (accounting only for macro-nutrients P + N)

Concerning the application of the secondary P product or mineral fertilizer in agriculture, this LCA excludes emissions and resource demand from transport of fertilizers (assuming comparable distances between products and mineral fertilizer) and during field application. However, heavy metal content of product and mineral fertilizers is accounted as emission into agricultural soil. Plant availability of P products is not taken into account in this LCA to exclude existing uncertainties in short-term or long-term uptake of P by the plants. However, products of the different P recovery processes can be associated with large variations in plant availability during pot and field tests (Römer 2013, P-REX D8.1), so this aspect is further discussed in LCA interpretation.

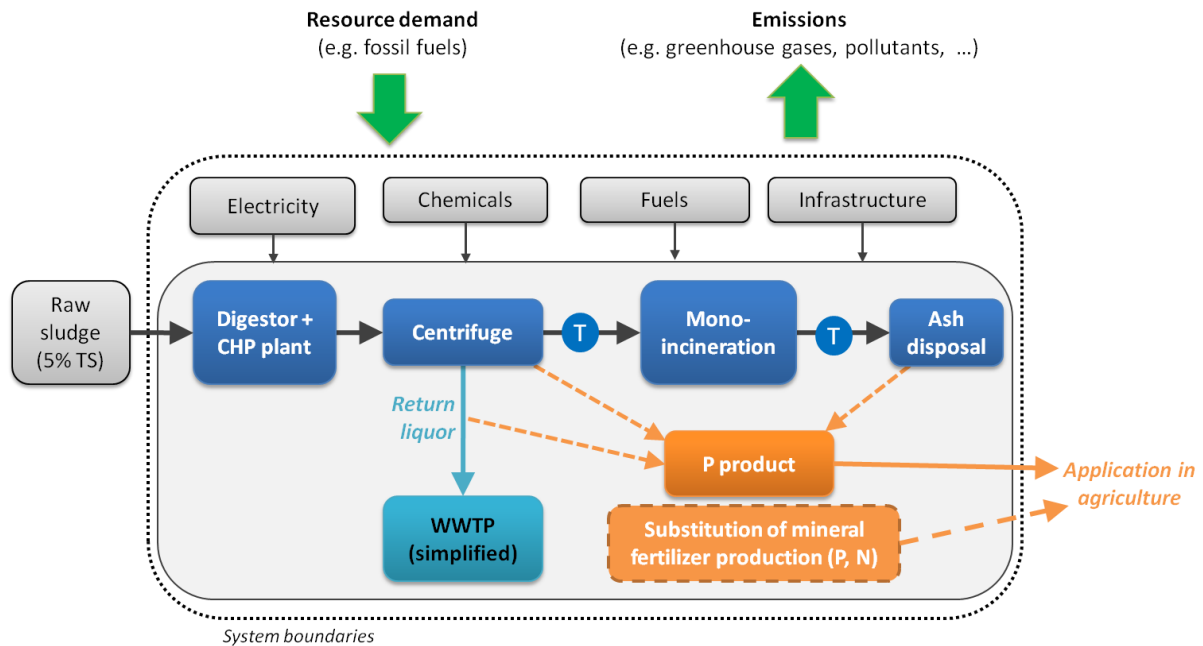

Figure 3-1: System boundaries of LCA for P recovery processes (T: Transport)

The geographical and temporal scope of the LCA is defined for Germany as a representative country for central and Western Europe, relating to the year 2014. Data for the reference system is assumed to represent mean operating conditions for a large-scale WWTP in Germany, whereas background data is related to German conditions (electricity mix) or EU/world averages (chemicals, transport, infrastructure, mineral fertilizer production).

3.5 Scenarios for P recovery

Two reference scenarios are modelled in this LCA as a baseline for comparison, representing the sludge treatment and disposal of ChemP or EBPR sludge of a 1 Mio pe WWTP in mono-incineration. In addition, 12 scenarios of P recovery are investigated here, representing 9 different technologies or processes (Table 3-2). It was decided to identify the scenarios based on their principal approach of P recovery rather than with their process name, so that the reader can relate directly to the type of process/pathway which is assessed. However, the direct link between scenarios and process names enables the clear identification of original processes, which is explicitly not avoided in this report. All scenarios are described in the following chapter.

Table 3-2: List of LCA scenarios

Scenario	Description	Process name	Data quality
Ref_EBPR	EBPR sludge treatment and disposal in mono-incineration	Reference	
Ref_ChemP	ChemP sludge treatment and disposal in mono-incineration	Reference	
Precipitation in sludge	Precipitation of struvite with Mg dosing in sludge before dewatering, pH adjustment via aeration	Airprex™	Full-scale
Precipitation in liquor 1	Precipitation of struvite with Mg in sludge liquor after dewatering, pH adjustment via NaOH	Pearl®	Full-scale
Precipitation in liquor 2	Precipitation of struvite with Mg in sludge liquor after dewatering, pH adjustment via NaOH	Struvia™	Large pilot
Sludge leaching 1	Leaching of digested sludge, dewatering and P recovery in liquor after dewatering by pH increase and Mg dosing, simultaneous precipitation of metals with Na ₂ S	Gifhorn process	Full-scale
Sludge leaching 2	Leaching of digested sludge, dewatering and P recovery in liquor after dewatering by pH increase and Mg dosing, metal complexation with citric acid	Stuttgarter process	Large pilot
Sludge metallurgic (stand-alone)	Thermal treatment of dried sludge in a shaft furnace (1'450°C) with coke addition and energy recovery via off-gas burning	Mephrec®	Model
Sludge metallurgic (integrated)	Thermal treatment of dried sludge in a shaft furnace (1'450°C) with coke addition and energy recovery via burning of off-gas in municipal solid waste incinerator	Mephrec®	Model
Ash metallurgic	Thermal treatment of ash in a shaft furnace (1'450°C) with coke addition	Mephrec®	Model
Ash leaching 1	Leaching of ash with H ₂ SO ₄ , solid-liquid separation, pH increase and precipitation of CaP with Ca(OH) ₂	LeachPhos	Large pilot
Ash leaching 2	Leaching of ash with recycled H ₃ PO ₄ , metal separation via staged ion exchange, production of H ₃ PO ₄	Ecophos	Full-scale planning
Ash thermo-chemical (stand-alone)	Thermochemical treatment of cold ash in rotary kiln (950°C), addition of Na and dried sewage sludge as reducing agent to remove metals via off-gas	Ash Dec	Pilot/model
Ash thermo-chemical (integrated)	Thermochemical treatment of hot ash from mono-incineration in rotary kiln (950°C), addition of Na and dried sewage sludge as reducing agent to remove metals via off-gas	Ash Dec	Pilot/model

For two processes of P recovery, more than one scenario is calculated in this LCA, because process integration and inputs can vary depending on the specific process layout:

- The metallurgic Mephrec process can be operated on sludge or ash as input material, and the sludge option may be realized in a stand-alone plant or may be integrated into an existing municipal waste incineration facility.
- Likewise, the Ashdec process can be operated stand-alone or integrated with an existing mono-incineration facility.

For both thermal ash treatments, integrated options are beneficial to reduce energy demand and improve the overall energy balance of P recovery. It has to be noted here that process data for integration of these processes into existing facilities is based on assumptions of the technology providers.

In general, many processes of P recovery are still under development and optimisation, and process configurations or specifications can be adapted and changed over time. The description of the processes in this report on the **status of collecting this information (End 2014) and may not represent the latest developments or modifications** of the different technologies.

All modelling and impact assessment is implemented using the LCA software UMBERTO NXT LCA (IFU and IFEU 2014). A screenshot of the reference model can be found in the annex (Figure 8-1). Process data is also summarized in technology fact sheets, which are available for download at the website (www.p-rex.eu).

3.5.1 Ref_EBPR and Ref_ChemP (reference scenarios)

These scenarios represent a reference sludge treatment line and disposal route of a 1 Mio pe WWTP reflecting the annual operation of a typical large-scale WWTP in Germany. The scenarios use different types of input sludge quality (cf. chapter 3.3) depending on the mechanism of P removal in the mainstream WWTP. They model sludge digestion at mesophilic temperature (35-37°C), dewatering of digested sludge in centrifuges with addition of polymer, transport of dewatered sludge by truck to a dedicated mono-incineration facility, mono-incineration of dewatered sludge in a fluidized-bed reactor with BAT energy recovery (electricity turbine and heat for district heating), and final truck transport and disposal of incineration ash in an underground deposit (Figure 3-2).

Biogas from sludge digestion is valorized in a CHP plant, producing electricity for on-site use or export and heat for internal use (e.g. digester heating). Sludge liquor from dewatering is recycled back to the mainstream process of the WWTP, which is modelled with a simplified approach taking into account the electricity required for removal of COD, N, and P. District heating and electricity is credited by substituting the equivalent products of grid electricity and district heating mix.

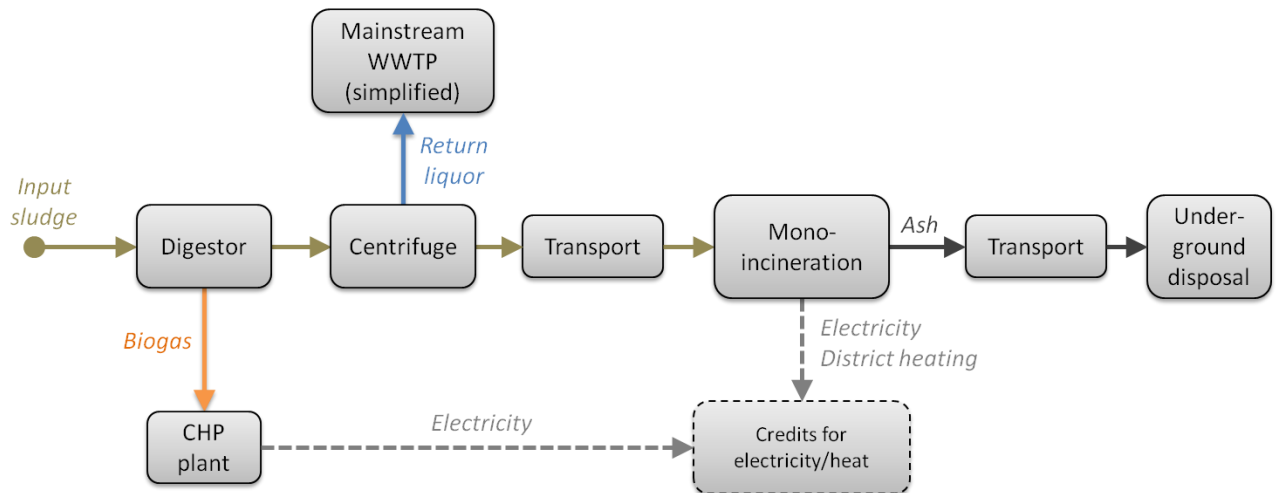

Figure 3-2: Reference scenarios Ref_EBPR and Ref_ChemP

3.5.2 Sludge precipitation (Airprex™)

The Airprex® process was originally developed in Berlin (Germany) by Berliner Wasserbetriebe in cooperation with PCS to prevent negative side effects of treating digested EBPR sludge, e.g. spontaneous precipitation of struvite in pipes and centrifuges, and lower dewaterability causing lower DS content in dewatered sludge (i.e. higher disposal costs) or higher polymer demand (Heinzmann 2005, Stumpf et al. 2008, Heinzmann and Lengemann 2013). Most of these unwanted side-effects are caused by high soluble $\text{PO}_4\text{-P}$ content in the sludge liquor, which can be decreased by dedicated struvite precipitation in a separate reactor. The Airprex™ process is currently operated at several WWTP in Germany (e.g. Berlin-Wassmannsdorf, Mönchengladbach) and the Netherlands (e.g. Amsterdam), installed directly after the digestors and prior to sludge dewatering.

In the Airprex® process, digested EBPR sludge is intensively aerated in a specific reactor (AirLift design) to increase pH by stripping of CO_2 (Figure 3-3). To enforce struvite precipitation, additional Mg is dosed in front of the reactor in the form of MgCl_2 solution. During the long retention time of the sludge in the AirLift reactor (typically 6-8h), struvite crystals are formed which sediment by gravity at the conical bottom of the reactor. Continuous reactor mixing is provided by a specific circular flow regime induced by the air injection at the bottom of the reactor. Sedimented struvite crystals are discharged in regular intervals, and subsequent washing removes residual sludge from the crystals. Wash water is recycled back to the WWTP inlet, while the struvite crystals are stored in open containers for drying before they can be marketed as a fertilizer product (e.g. Berliner Pflanze®, which contains struvite crystals from Berlin-Wassmannsdorf and is certified as fertilizer product under REACH and EU fertilizer regulations).

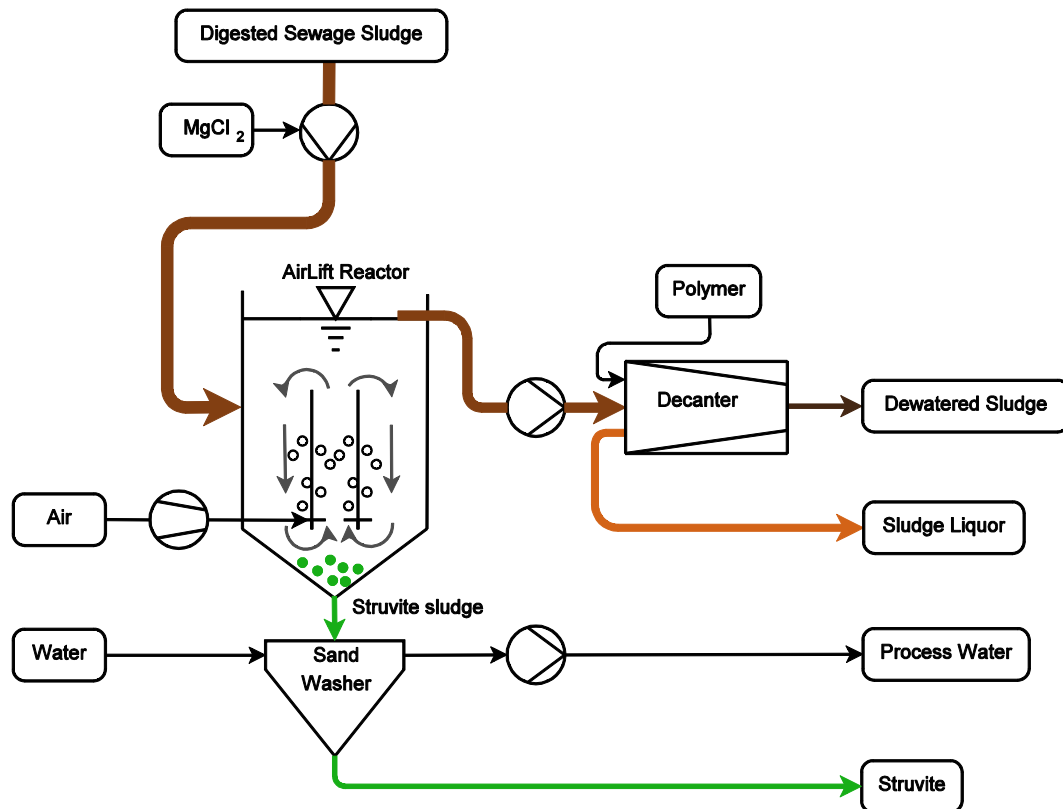

Figure 3-3: Process scheme of Airprex™ process

The Airprex™ process can be applied within one reactor (e.g. Berlin-Wassmannsdorf) or with several reactors (e.g. Mönchengladbach) depending on site-specific conditions and reactor performance. While dissolved $\text{PO}_4\text{-P}$ can typically be decreased $>90\%$ in the Airprex reactor, harvesting of struvite crystals is not complete due to hindered sedimentation of small crystals and loss of crystals with output sludge.

A positive side-effect of Airprex™ aside from preventing struvite incrustations in downstream pipes and dewatering equipment is the improved dewatering of the treated sludge. Typically, sludge dewatering can be improved substantially with Airprex™ installations, yielding better DS content in dewatered sludge (increase of 1-4% DS depending on sludge quality) and a decrease in polymer demand.

3.5.3 Liquor precipitation 1 (Pearl®)

The Pearl® process is developed, commercialized and licensed by OSTARA Nutrient Recovery Technologies Inc. (Vancouver, Canada) which specializes in nutrient recovery from municipal and industrial wastewaters. Pearl® is designed to prevent unwanted struvite incrustation after sludge dewatering in WWTPs using EBPR and to reduce the P return load to the mainstream process by decreasing dissolved $\text{PO}_4\text{-P}$ concentration in the liquor. In addition, eliminated P can be recovered as a premium slow-release fertilizer product in the form of defined struvite pellets (CrystalGreen®). The Pearl® process is currently operated at several WWTPs in Canada, the US and the UK (e.g. Slough).

The Pearl® crystallization reactor is installed directly after dewatering and treats the sludge liquor (Figure 3-4). Struvite is precipitated in the reactor by dosing of a Mg source (e.g. $MgCl_2$) and increasing pH with NaOH dosing if necessary, depending of the actual pH and buffering capacity in the liquor. Internal recirculation of liquor in the PEARL® reactor assures proper mixing and good crystal growth, while the specially designed conical reactor shape guarantees uniform crystal size and optimum hydraulic conditions for crystal growth. Crystalline pellets (“prills”) reaching the desired size sink to the bottom of the reactor where they are harvested. Struvite pellets are dried in a fluidized bed dryer before they are marketed as premium fertilizer product. Due to the defined crystallisation process and the controlled hydraulics, more than 90% of the struvite prills formed in the reactor can be harvested as fertilizer product.

The Pearl® process can also be combined with a dedicated release of PO_4 -P from EBPR sludge prior to digestion (WASSTRIP® setup), but this modification is not analysed in this LCA study.

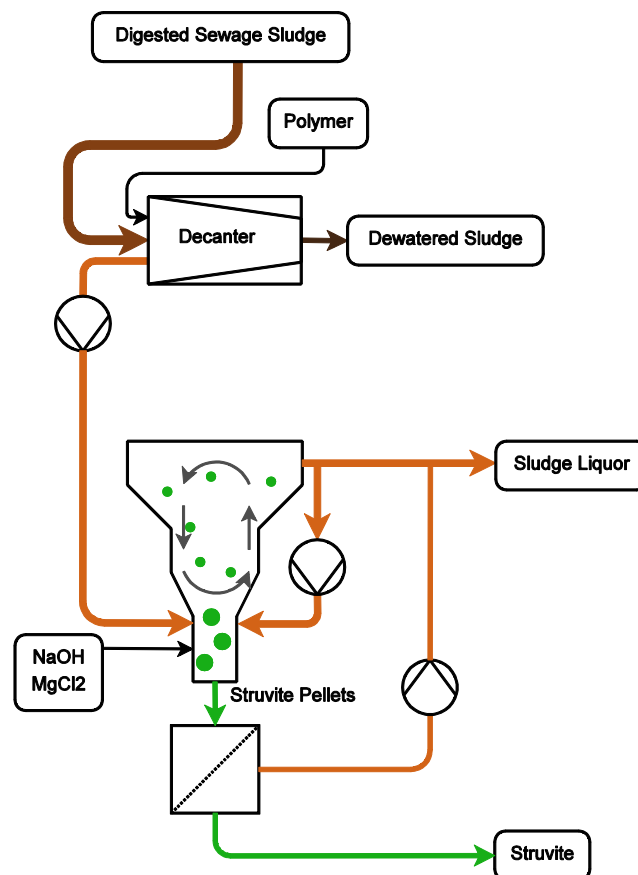

Figure 3-4: Process scheme of Pearl® process

3.5.4 Liquor precipitation 2 (Struvia™)

The Struvia™ process is a modification of the phosphorus recovery technology Phostrip, originally developed by the Japanese company Showo Kankyo Systems K.K. (SKS). Since 2011, SKS is owned by Veolia Water which has developed the process into the current state and renamed the process to Struvia™. The process targets the removal of $\text{PO}_4\text{-P}$ from the sludge dewatering liquor in the form of struvite to reduce P return load to the mainstream process and enable P recovery.

For recovering struvite from sludge liquor of WWTPs using EBPR, Struvia™ combines a continuously stirred tank reactor (CSTR) with a lamella settler on top. After dosing of a Mg source (e.g. MgCl_2) and adjustment of pH with NaOH, the liquor is intensively mixed using a specific mixing device (Turbomix®) to promote growth of struvite crystals in the reactor. Typical hydraulic retention times (HRT) in the CSTR are in the range of 0.5-2h. The lamella settler sits on top of the CSTR (Turboflo® configuration) and should prevent struvite crystals from leaving the reactor with the outgoing liquor, so that struvite can be harvested at the bottom of the reactor in form of fine powder. Further drying of struvite powder at low temperature is required before it can be further processed into a fertilizer product.

The Struvia™ process has been extensively tested in a large pilot installation at Brussels WWTP (2013-2014), working on sludge liquor and a mixture of liquor and effluent of the wet air oxidation process (Athos). It has not been in operation at full-scale in the course of the P-REX project.

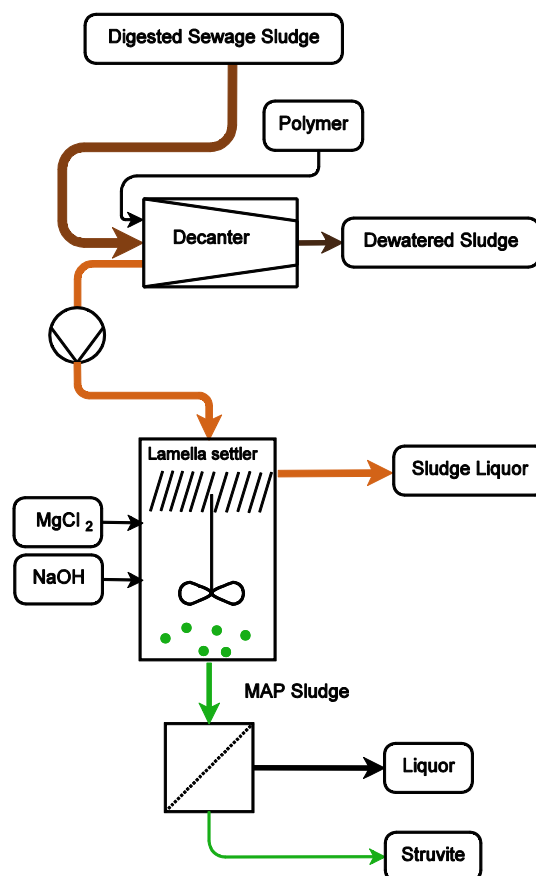

Figure 3-5: Process scheme of Struvia™ process

3.5.5 Sludge leaching 1 (Gifhorn)

The basic concept of this process was originally developed in 2000 by Seaborne Environmental Laboratory AG (Germany) in order to recover nutrients from liquid manure. Since then, the Seaborne process was modified, optimized and implemented in full scale at WWTP Gifhorn (Hermanussen et al. 2012), which gave the current name of this process ("Gifhorn process"). In the Gifhorn process configuration as assessed in the P-REX project, digested sludge is directly acidified to pH = 4.5 by adding H_2SO_4 in a first reactor (HRT = 1h), thus dissolving PO_4 -P into the liquor which is chemically bound in the sludge (Figure 3-6). At this pH, considerable amounts of metals (Fe, but also heavy metals) are also mobilized into the sludge liquor. To prevent the transfer of Fe and heavy metals into the final P product, dissolved metals are precipitated as sulfides in a second step, adding Na_2S and raising the pH to 5.6 by addition of NaOH. Leached sludge is then dewatered in a centrifuge with polymer addition, so that highly loaded liquor and sludge are separated. In a second reactor, precipitation of the P product in liquor is initiated by small dosing of $Mg(OH)_2$ to supply additional Mg and raise the pH to 9, eventually dosing NaOH for pH control. Due to the liquor composition at Gifhorn, the P product is precipitated as a mixture of struvite and mostly calcium phosphate (hydroxylapatite) in the current Gifhorn process. After precipitation, the P product is separated in a second decanter and recovered as final product.

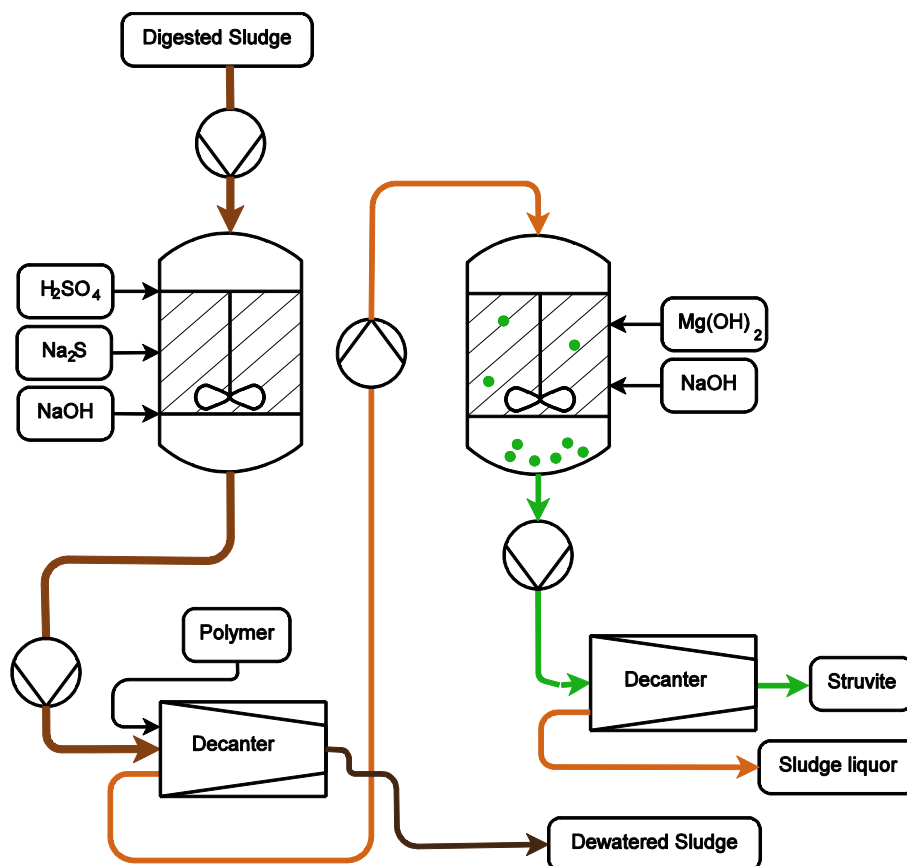

Figure 3-6: Process scheme of Gifhorn process

3.5.6 Sludge leaching 2 (Stuttgart)

The Stuttgart process for P recovery from digested sludge of WWTPs with ChemP removal was developed at University of Stuttgart (Germany) at the Institute for Sanitary Engineering (ISWA). After lab development and optimisation, a large pilot plant is operated at WWTP Offenburg (Germany) since 2011, working on a partial flow of digested sludge (5% of total sludge volume). The process is still in optimisation to balance P recovery potential and chemical demand (Antakyali et al. 2013).

The Stuttgart process is based on acidic leaching of digested ChemP sludge at pH = 4 by addition of H_2SO_4 in a first reactor (Figure 3-7). Chemically bound P is dissolved as PO_4 -P into the liquor together with a fraction of metals such as Fe or heavy metals. After solid-liquid separation in a chamber filter press with polymer dosing, citric acid is dosed in a second reactor to mask dissolved metals in liquor, preventing their transfer into the final P product. Struvite precipitation is then initiated by dosing of a Mg source (MgO) and raising the pH to 8.5, using NaOH for final pH control. Precipitated struvite is harvested as a powder at the bottom of a sedimentation tank or can be separated from liquor in a second solid-liquid separation step such as a chamber filter press.

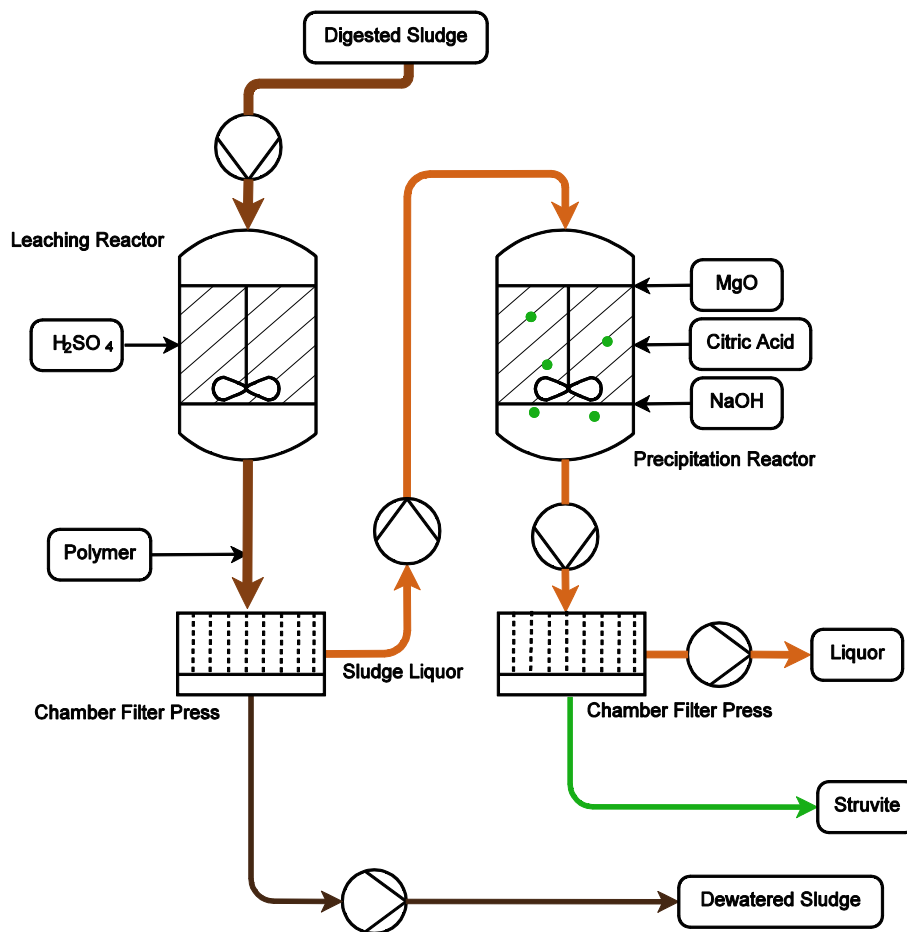

Figure 3-7: Process scheme of Stuttgart process

3.5.7 Sludge or ash metallurgic (Mephrec®)

The Mephrec® process was developed by the company Ingitec (Leipzig, Germany) for recovery of phosphorus from sewage sludge and/or ash. It is based on a melting process in a shaft furnace at high temperatures, yielding a metal phase and an inorganic slag where P can be recovered (Scheidig et al. 2010). The process has been tested in principle in 2008 at small-scale trials in Freiberg and is planned for pilot trials in the city of Nuremberg (Hagspiel 2015).

Two different feed materials can be used in the Mephrec® furnace: dried sewage sludge or incineration ash. Both substrates have to be pressed in briquettes before entering the shaft furnace from the top, together with coke as fuel and reducing agent and slag former (Figure 3-8). Pure oxygen is blown into the lower part to reach high temperatures of 1450°C, at which sludge or ash briquettes are melted in the furnace. While organic content of sludge is gasified and leaves the reactor with the off-gas, metal compounds are reduced into their elemental form. Volatile metals (e.g. Cd, Hg, Pb, Zn) are evaporated into the gas phase, whereas non-volatile metals and other inorganics are found in the smelting. Most of the P content is found in the slag (>85%), which can be separated from the melted metals by careful run-off at different levels of the furnace base. Outputs of the Mephrec® reactor are off-gas (highly calorific in case of sludge as input material), metal alloy, and P-rich slag. The slag contains mostly silico-phosphates, which are comparable to “thomas phosphate” (Scheidig et al. 2013).

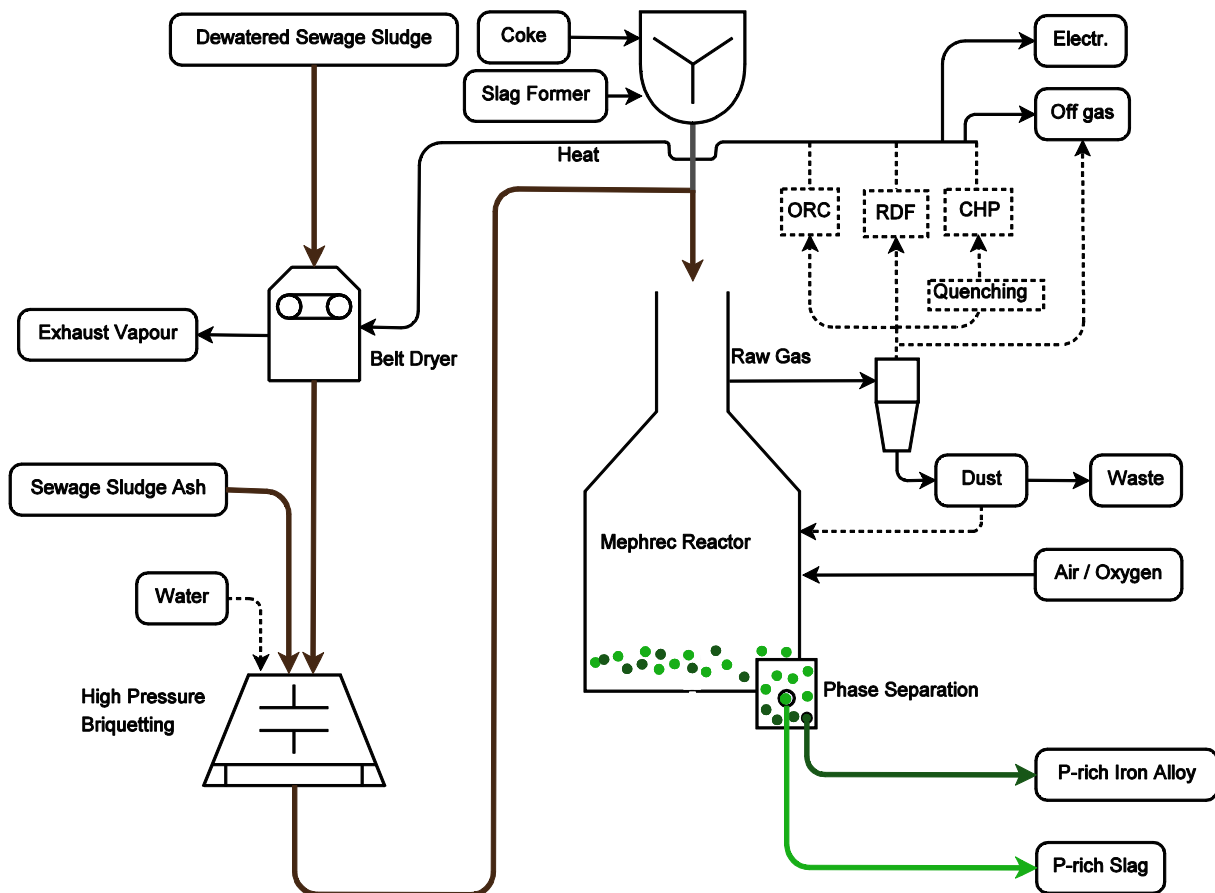

Figure 3-8: Process scheme of Mephrec® process

In case of dried sludge as input material, the off-gas from the Mephrec® furnace has a high calorific value, and its energy content can be further exploited after dust separation with different possible options (Figure 3-8):

- 1) Direct burning of off-gas in the furnace head (“stand-alone” option) and exploitation of heat via heat exchangers and organic rankine cycle (ORC), yielding electricity as output. Excess heat can be used for drying of input sewage sludge.
- 2) Direct burning of off-gas in a municipal waste incineration (MSWI) plant (“integrated” option) and exploitation of heat via steam turbine. Excess heat of the MSWI plant can be used for drying of sewage sludge.
- 3) Quenching of off-gas and multi-stage gas cleaning for direct feed into a CHP plant for electricity and heat production. However, this option is technically complex and was not tested before, so that it is not further investigated in this LCA study.

Exploited off-gas is finally subjected to gas cleaning to guarantee emission limits. In case of ash as input material to the Mephrec® process, no energy recovery is assumed from off-gas.

3.5.8 Ash leaching 1 (Leachphos)

The LeachPhos process was developed by BSH Umweltservice GmbH. It is based on acidic leaching of mono-incineration ash at low pH by the addition of diluted H_2SO_4 (Figure 3-9). After solubilisation of PO_4 -P from the ash, solids are separated in a filtration unit, and residual filter cake is transported to disposal. The highly-loaded liquid phase is treated in a second reactor by the addition of lime slurry and NaOH, gradually rising the pH and recovering a P product as a mixture of Al-, Fe-, and Ca-phosphates. Calcium phosphates or magnesium ammonium phosphate (struvite) are targeted output materials for future industrial-scale plants. In the Leachphos process, heavy metals (e.g. Cd, Cu, Zn) are only partially dissolved and precipitated in the product, leading to acceptable mass fractions in the output material. Final P product is separated in a second filtration stage, whereas the remaining heavy metals are quantitatively precipitated at $pH > 9$ with a precipitating agent and separated for disposal. Process water can be discharged after metal removal.

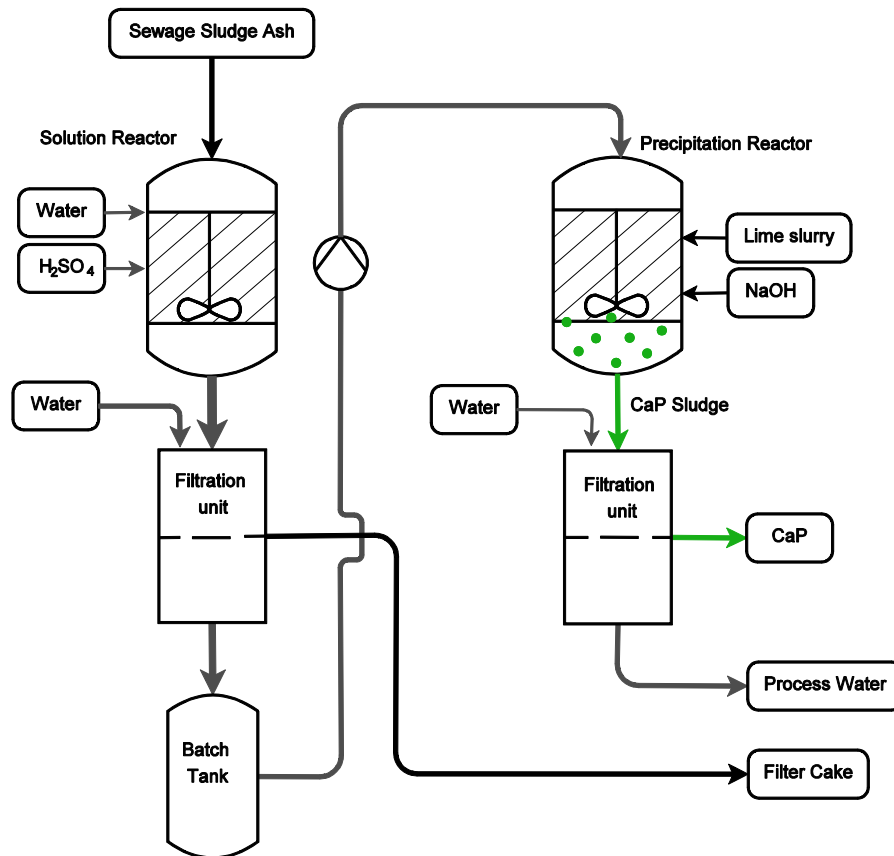

Figure 3-9: Process scheme of LeachPhos process

3.5.9 Ash leaching 2 (Ecophos)

The EcoPhos process was originally developed by the phosphate industry to process low-grade P input material (e.g. P rock with high contamination of heavy metals) into a high-quality P product (phosphoric acid in feed-grade quality). Recently, it has been modified and tested for mono-incineration ash as input material. A full-scale plant for processing of mono-incineration ash into a P product is currently under construction in Dunkerque (FR).

The Ecophos process is based on the digestion of ash into a large excess of H₃PO₄ (Figure 3-10), which is recycled from the product side. After digestion, insoluble residues are removed via filtration and disposed as inert material. The liquid solution contains a high amount of H₃PO₄ and dissolved impurities from the ash. This solution is purified by a multi-stage ion exchange (IEX) process, thus removing divalent salts (Mg, Ca), metals (Fe, Al), and other impurities such as heavy metals. Ion exchange resins are regenerated with HCl, thus introducing the acid equivalents into the process which are required for ash digestion. The different regeneration solutions of the IEX are valuable by-products of the process, which can be valorized as Ca/Mg solution or Al/Fe solution, whereas other impurities are disposed as wastewater.

After purification of the solution, a part of the H₃PO₄ is recycled back to the ash digestion, whereas another part is recovered as H₃PO₄ product and is further concentrated using steam. The final product is a H₃PO₄ solution with high concentration and low impurities.

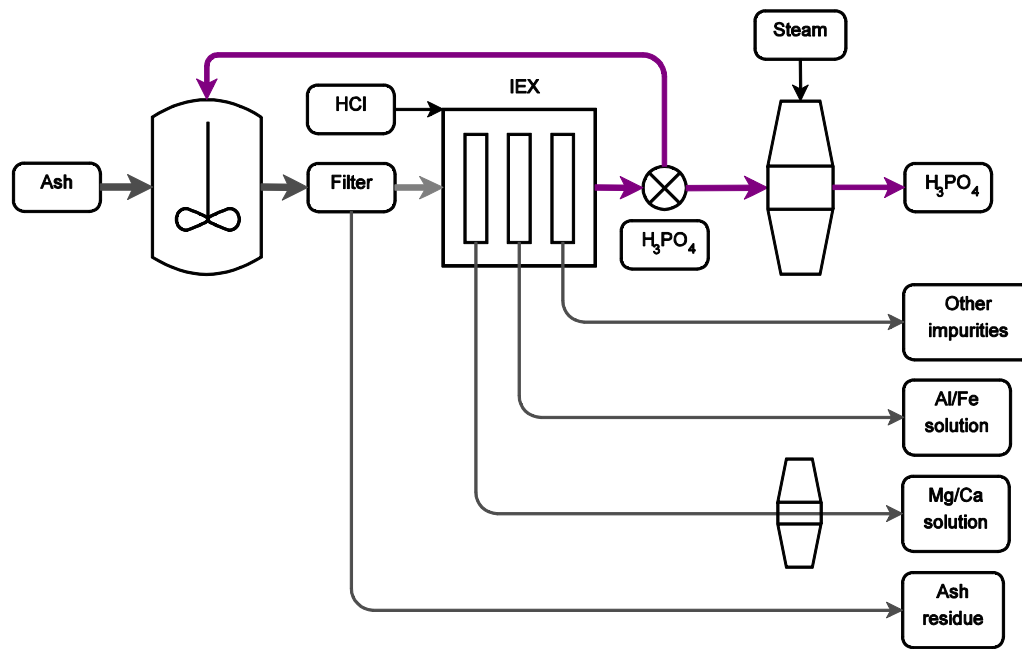

Figure 3-10: Process scheme of Ecophos process

3.5.10 Ash thermo-chemical (Ash Dec)

The Ash Dec process was jointly developed by Outotec and BAM Federal Institute for Materials Research and Testing. It is based on the thermo-chemical treatment of mono-incineration ash in a rotary kiln to increase plant availability and reduce heavy metal content of the ash. The Ash Dec process has been tested in lab and pilot scale (Adam 2009, D3.1), but has not been realized in full-scale to date.

In the Ash Dec process, pre-heated ash is mixed with alkali additives (Na salts, e.g. NaSO_4) and a reducing agent (e.g. dried sewage sludge) before entering a rotary kiln. In the rotary kiln, the mixture is heated to 900-1000°C for at least 20 min using natural gas as fuel for the kiln. During the process, phosphate phases present in the ash are transformed into plant-available forms (mostly NaCaPO_4), whereas volatile heavy metals (As, Cd, Hg, Pb, Zn) are evaporated in the reducing atmosphere and are thus partially removed via the gas phase. Off-gas has to be further treated to remove dust (as fly ash containing heavy metals) and combustion gases to acceptable limits. The final product of the Ash Dec process is comparable to “Rhenania phosphate” which was produced as plant fertilizer in the 20th century. Besides the P product and the off-gas, no further waste is generated in the process.

In the “stand-alone” option, the Ash Dec process needs additional fuel to heat up the ash before entering the rotary kiln, and the off-gas treatment has to be realized specifically for the Ash Dec plant. If the Ash Dec process can be integrated in an existing mono-incineration facility, hot ash can be transferred directly from the incineration process, so that fuel demand for Ash Dec can be reduced. In addition, off-gas from Ash Dec can be treated in the off-gas cleaning of the mono-incineration, saving on investment costs for the process.

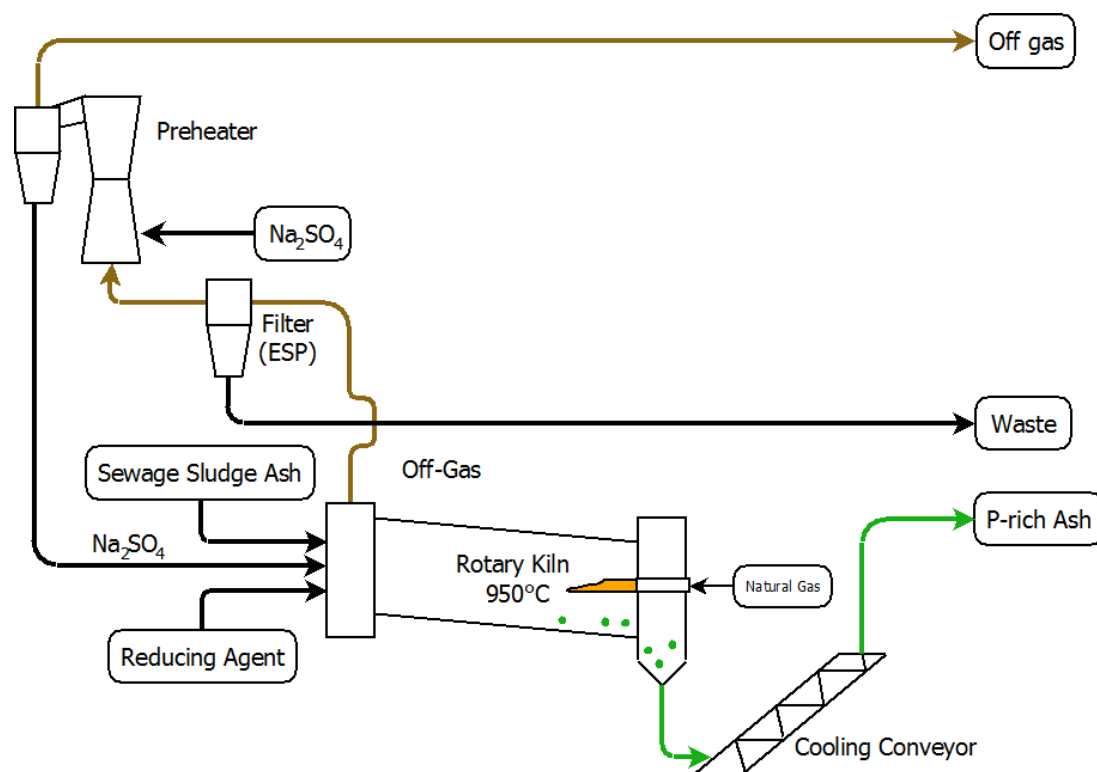

Figure 3-11: Process scheme of Ashdec process

3.6 Data quality

The collection of input data for the different processes of P recovery relies mainly on primary data collected from technology providers and operators (Table 3-3). From this perspective, data quality for P recovery processes is assumed to be high and representative for the individual technologies, representing the status at the time of data collection (2014). However, many processes have not been realized in full-scale yet, so that input data of different sizes of installations has to be used for this LCA. Hence, careful up-scaling of process data from pilot installations to full-scale plants was required for several processes, which was done in close contact with technology providers and operators. In addition, transfer of site-specific process data to the defined conditions in the reference model was required to reflect process performance and efficiencies in a most realistic way. Internal cross-check and intensive validation of final datasets within the project team and with the data providers was necessary to ensure valid input datasets and high quality and representativeness of results.

The reference system was defined together with the project consortium based on existing data of sludge and ash quality and long-term experience of the assessment team. Background processes are modelled with datasets from Ecoinvent v3.1 database (Ecoinvent 2014), representing conditions in Germany (e.g. for electricity mix) or EU/global average. For mineral fertilizer production, Ecoinvent datasets still rely on primary sources of the 1990s (e.g. Patyk and Reinhardt 1997), but they represent the latest available datasets for mineral P and N fertilizer production according to information of the European Fertilizer Association (EFA with Frank Brentrup (Yara) as LCA representative). Efforts to update these datasets within the P-REX project were not successful.

Table 3-3: Data quality of input data

Process	Data source	Data quality
Reference system		
Input sludge	Berlin WWTP, Krüger and Adam 2014	High
Digestion and dewatering	Berlin WWTP, MUNLV 1999	High
Return load treatment	ATV 2000	High
CHP plant	Ronchetti et al. 2002	Medium
Mono-incineration	Outotec (BAT plant)	High
P recovery processes		
Airprex™	PCS (full-scale)	High
Pearl®	Ostara (full-scale)	High
Struvia™	Veolia (large pilot)	Medium
Gifhorn	PFI (full-scale)	High
Stuttgart	ISWA (large pilot)	Medium
Mephrec®	Ingitec (small pilot/model)	Low/medium
Leachphos	BSH (large pilot)	Medium
Ecophos	Ecophos (full-scale planning)	High
Ash Dec	Outotec (pilot/model)	Medium
Background data (Ecoinvent 2014)		
Electricity mix	Mix of Germany 2010	Medium
Chemicals and materials	EU or global datasets	Medium
Transport	Truck transport (EU)	Good
Mineral fertilizer production	Datasets from 1990s	Low/Medium

3.7 Selection of indicators for LCA impact assessment

Impact categories and respective environmental indicators are selected based on experience from previous LCA studies in this field. Although individual recommendations for indicator models exist from the JRC per impact category (Hauschild et al. 2013), it is decided to stick to the ReCiPe methodology (Goedkoop et al. 2009) for the impact assessment in this study for reasons of consistency. LCA indicator results are reported at the midpoint level only, because further modelling towards specific endpoints (e.g. human health, ecosystems, or resources) introduce

more uncertainty in the approach and lead to less transparency and reproducibility of results. Therefore, midpoint indicators from ReCiPe are used, relating to the hierarchist perspective concerning time horizons (Goedkoop et al. 2009). Long-term emissions from mining sites, landfills, nuclear deposits etc. beyond a timeframe of 100a are not accounted in this study.

For impact assessment of human and ecotoxicity, the consensus model USEtox® is applied in this study (Rosenbaum et al. 2008), although available characterisation factors for some compounds (e.g. metals) are still flagged as “interim”. Traditional toxicity indicators from ReCiPe are calculated in sensitivity analysis for human and freshwater ecotoxicity to reveal the impact of modelling choice on the LCA outcomes.

Besides the selected midpoint indicators, two indicators for demand of non-renewable fuels are added, namely cumulative energy demand of fossil and of nuclear fuels (VDI 2012). Although these indicators report results on an inventory level, they are useful in describing primary energy demand of the processes in a conclusive approach.

Table 3-4: Indicators for impact assessment

Indicator	Abbr	Unit	Main contributors ¹	Source ²
Cumulative energy demand (fossil)	CEDe _{foss}	MJ	Fossil fuels (lignite, hard coal, natural gas, crude oil)	VDI 4600
Cumulative energy demand (nuclear)	CEDe _{nucl}	MJ	Nuclear fuels (uranium)	VDI 4600
Metal depletion potential	MDP	kg Fe-eq	Metals, inorganic resources	ReCiPe
Global warming potential (100a)	GWP	kg CO ₂ -eq	CO ₂ (fossil), N ₂ O, CH ₄	IPCC
Terrestrial acidification potential (100a)	TAP	kg SO ₂ -eq	SO ₂ , NO _x , NH ₃	ReCiPe
Freshwater eutrophication potential	FEP	kg P-eq	P emissions in water and soil	ReCiPe
Marine eutrophication potential	MEP	kg N-eq	N emissions in air, water and soil	ReCiPe
Ecotoxicity (freshwater)	ETP	CTU _e	Heavy metals, organic pollutants	USEtox ³
Human toxicity	HTP	CTU _h	Heavy metals, organic pollutants	USEtox ³

¹ Long-term emissions > 100a in ecoinvent datasets not accounted

² VDI 2012, IPCC 2007, Goedkoop et al. 2009 (midpoint, hierarchist perspective), Rosenbaum et al. 2008

³ ReCiPe indicators of human toxicity potential and freshwater ecotoxicity potential used for sensitivity analysis

3.8 Normalisation

In normalisation, LCA indicator results are related to the total environmental impact per inhabitant in a reference area (here: EU27). Thus, normalised results reveal the individual contribution of each impact category to the total environmental footprint of societal activities, indicating if a specific environmental impact of P recovery has a higher or lower contribution. Normalised results can help to identify those areas of environmental impact that are highly affected by P recovery, always relating to the actual environmental footprint of society. Normalisation data is collected for all indicators from latest available sources for EU27 countries (Table 3-5).

Table 3-5: Normalization data for impact indicators

Indicator	Unit	Total impacts in EU27	Source
Cumulative energy demand (fossil)	MJ/(pe*a)	104'000	Eurostat 2015*
Cumulative energy demand (nuclear)	MJ/(pe*a)	18'950	Eurostat 2015*
Metal depletion potential	kg Fe-eq/(pe*a)	713	ReCiPe 2015
Global warming potential (100a)	kg CO ₂ -eq/(pe*a)	11'215	ReCiPe 2015
Terrestrial acidification (100a)	kg SO ₂ -eq/(pe*a)	34.4	ReCiPe 2015
Freshwater eutrophication	kg P-eq/(pe*a)	0.415	ReCiPe 2015
Marine eutrophication	kg N-eq/(pe*a)	10.12	ReCiPe 2015
Ecotoxicity (freshwater)	CTU _e /(pe*a)	8'720	Laurent et al. 2011
Human toxicity	CTU _h /(pe*a)	8.47E-4	Laurent et al. 2011

** gross inland energy consumption in 2013 for fossil (solid, petroleum, gas, waste) and nuclear fuels, recalculated with 41.868 MJ/kg oil-eq and 500 Mio pe for EU27*

3.9 Sensitivity analysis

Sensitivity analysis checks the influence of definitory choices or data variation on the outcomes of the LCA. Both aspects can have a decisive impact on total indicator scores, but also on interpretation and stability of the results. Regarding the multitude of definitions and data assumptions that have been included in this LCA, sensitivity analysis has to be restricted to a defined set of aspects that were identified as valuable for this exercise. A systematic analysis of uncertainty and sensitivity of all parameters (e.g. via Monte-Carlo-Analysis) is out of the scope of this study and would require significant efforts in time and modelling.

In particular, sensitivity analysis for this LCA includes the following aspects:

- **Alternative disposal routes for dewatered sludge: co-incineration or direct application in agriculture.** Both options will have an impact on the recovery potential for energy and nutrients content of the sludge. Whereas co-incineration is expected to increase energy recovery, P recovery from these ashes is not feasible due to dilution effects leading to low P content of the ash. Hence, a combination of P recovery from sludge via leaching and downstream co-incineration could provide an option for both energy and P recovery with acceptable efficiencies. In comparison, agricultural application of sludge enables the complete recycling of P content to agriculture, but will also transfer the entire load of heavy metals onto agricultural soil. Besides full P recycling, agricultural application of sludge will also enable to utilize N content of the sludge to some extent.
- **Alternative indicators for human and ecotoxicity:** existing LCA impact models for human and ecotoxicity are affected with relatively high uncertainties in characterization factors for toxicity of inorganic and organic pollutants, particularly related to heavy metals (Ligthard et al. 2004). Although this LCA applies the recent consensus model USEtox®, other toxicity models are available. To check the influence of the indicator model on the results, alternative indicators for human and ecotoxicity are calculated for assessing the product quality in this LCA.
- **PO₄-P content in sludge/liquor:** dissolved PO₄-P content determines total recovery potential of sludge or liquor processes which do not involve dedicated acidic leaching of P upstream. However, PO₄-P content can vary significantly between individual WWTPs, which will thus have a major impact on efficiency of these processes. This effect is exemplified by varying dissolved PO₄-P concentration in the reference model for selected scenarios of P recovery.
- **Effect of direct sludge precipitation (Airprex™) on dewaterability:** this factor has a decisive impact on energy credits of this particular pathway for P recovery. As the real impact on dewaterability is difficult to quantify, a range of potential effects is calculated for this process to show the impact of this factor on the overall environmental footprint of this pathway.

4 Life Cycle Inventory (input data)

This chapter summarizes all input data of the reference system and the P recovery scenarios, listing also information on background datasets and accounting of products and by-products by substitution of primary production.

4.1 Reference system

The reference system consists of sludge digestion and biogas valorisation in a CHP plant, sludge dewatering and treatment of return load, transport, mono-incineration, and ash disposal. Most important process parameters are based on experience of the P-REX partners and previous studies in this field, amended by literature data (Figure 4-1). Details of each process are described below.

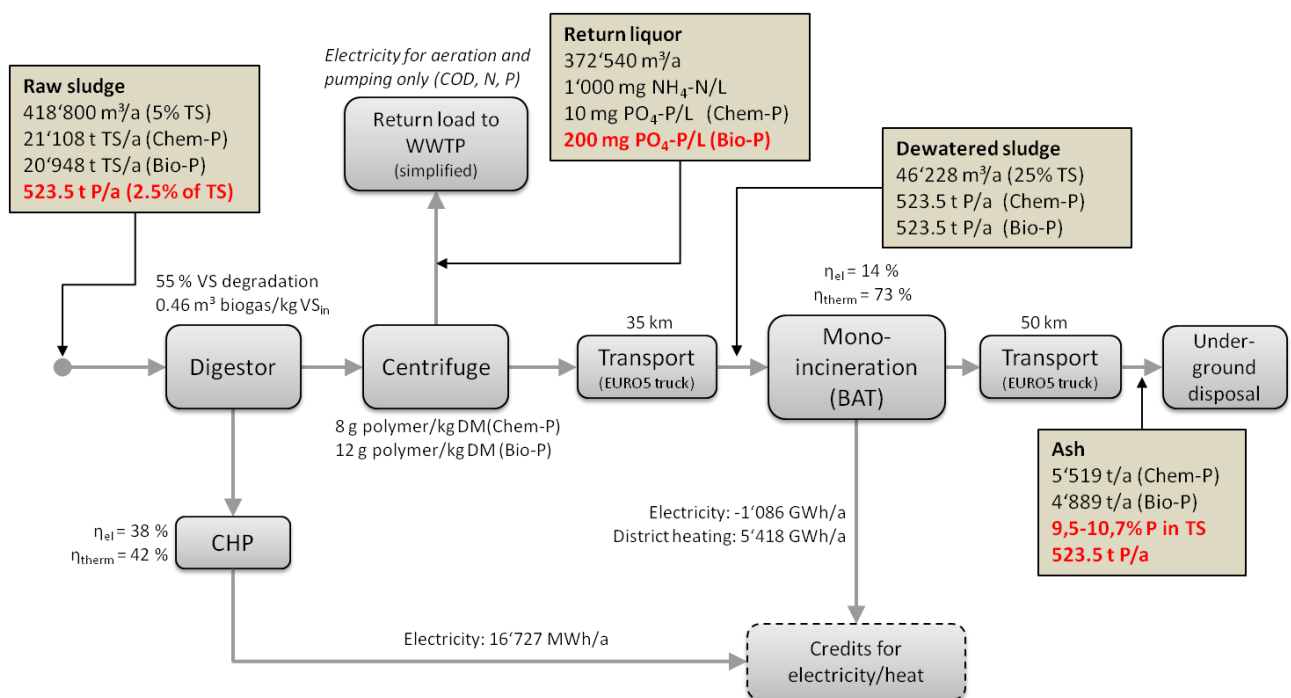

Figure 4-1: Reference system

4.1.1 Digester and CHP plant

The digester represents a state-of-the-art mesophilic digestion process at 35-37°C with typical retention times of 15-20d. During the digestion process, 55% of volatile solids (VS) are degraded and converted into biogas (463 NL/kg VS_{in}) with a methane content of 61 Vol-% CH₄. The degradation and gas yield are in the upper range of typical values for mesophilic digestion, assuming optimum operation. Electricity demand for the entire digester (mainly for mixing and pumping of sludge) is estimated with 3 kWh/m³ input sludge (MUNLV 1999), whereas thermal energy demand for digester heating is assumed to 30 kWh/m³ input sludge (MUNLV 1999). Digested sludge contains dissolved methane, assuming 100% saturation (= 18 mg/L CH₄ at 30°C). This methane is stripped in the downstream dewatering.

Valorisation of biogas in the CHP plant is assumed to produce electricity and heat, assuming an electrical efficiency of 42% and thermal efficiency of 38% for a modern CHP unit. Electricity

demand for CHP operation and gas cleaning is assumed with 0.1 kWh/m³ biogas (~ 1% of energy content). CHP plant emissions are based on previous studies (Ronchetti et al. 2002; Remy 2010), accounting for 0.7% of total CH₄ as leakage or slip emissions and 0.01% for testing the emergency flare.

4.1.2 Dewatering in centrifuge

Digested sludge is dewatered in a centrifuge (decanter), using polymer as flocculant to improve dewaterability results. The dewatered sludge has a final TS content of 25%, thus being in the medium range of dewaterability of mixed sludge (20-30% TS). Electricity demand of the centrifuge is assumed to 2.5 kWh/m³ (MUNLV 1999). Polymer demand is depending on sludge composition, with EBPR sludge usually requiring more polymer than ChemP sludge. In this study, a polymer demand of 12 g/kg TS for EBPR sludge and 8 g/kg TS for ChemP sludge is estimated, which is in the medium range for mixed digested sludge (5-20 g/kg TS).

4.1.3 Return load treatment in mainstream WWTP

Return load from dewatering is heavily loaded with nutrients N/P, but also COD (Table 4-1). Energy demand for the treatment of this return load in the mainstream WWTP process is estimated by calculating an oxygen demand, assuming 1 kg O₂ per kg COD_{removed}, 4.57 kg O₂ per kg NH₄-N_{removed}, and an oxygen recovery of 2.86 kg O₂ per kg NO₃-N_{removed} (ATV 2000). Effective energy demand for oxygen transfer via aeration is assumed with 0.5 kWh per kg O₂. Removal efficiencies in the mainstream process are estimated with 90% for COD, 99% for NH₄-N (= full nitrification), 80% for denitrification, and 96% for P assuming biological P removal. Additional pumping for recirculation in pre-denitrification is estimated with 1 kWh/kg N_{removed}, while biological P removal requires 0.37 kWh/kg P (MUNLV 1999). Direct air emissions are estimated with 0.6% of input N as N₂O (Wicht 1996) and 0.6% of input NH₄ as NH₃ (Bardtke et al. 1994), whereas direct emissions in surface water are calculated based on liquor loads and removal efficiencies in the mainstream.

Table 4-1: Composition of sludge liquor in reference system

Parameter		Sludge liquor	
		Chem-P	EBPR
Volume	<i>m³/a</i>	372'500	372'500
Total solids (TS)	<i>mg/L</i>	2'000	2'000
COD	<i>mg/L</i>	1'500	1'500
N	<i>mg/L</i>	1'000	1'000
PO₄-P in liquor	<i>mg/L</i>	10	200
Fe	<i>mg/L</i>	0	0
Mg	<i>mg/L</i>	15	15

4.1.4 Mono-incineration and ash disposal

Dewatered sludge is transported by truck (35km) to a dedicated mono-incineration plant (fluidized-bed incinerator). Process data for the mono-incineration plant in terms of energy balance and material demand for operation is based on a BAT mono-incineration plant and provided by Outotec. Based on the lower heating value (LHV) of the input sludge, efficiency of the steam turbine is estimated with 14% of LHV as generated electricity, while 73% of LHV are supplied in form of district heating to the nearby heating grid. Electricity demand of the incinerator is estimated with 0.23 kWh/kg TS, while fuel demand is restricted to natural gas for start-up (0.05 MJ/kg TS), assuming autothermal incineration of sludge with internal pre-drying. Fluidized bed is realized by sand addition (0.7 g/kg TS).

Off-gas cleaning of mono-incineration requires additives (0.3 g coke, 5 g lime/kg TS, 16.5 g NaOH (30%), and 12.1 g NH₃ (25%) per kg input TS) and produces waste (42 g gypsum) for disposal. Off-gas emissions are estimated based on previous studies (61 mg SO₂, 243 mg NO_x, 15 mg NH₃, 61 mg CO, 12 mg dust, 25 mg HCl per kg input TS). Heavy metals are completely bound in ash or off-gas cleaning, but a transfer of 10% of Hg load into the air is assumed. N₂O emissions from fluidized bed incinerators are known to be substantially high (Sanger et al. 2001; Svoboda et al. 2006) due to incineration freeboard temperatures of 900°C, so that an increased emission factor of 990 mg N₂O/kg TS is assumed for mono-incineration (IPCC 2006).

The resulting composition of ash is listed below (Table 4-2). This ash of mono-incineration is transported by truck (50 km) before final disposal in underground deposit. No further emissions into the environment are assumed from the deposit, as incineration ash as hazardous material should be deposited in specialized landfills or underground mines, prohibiting any leaching or emission of pollutants from the ash.

Table 4-2: Composition of ash in reference system

Parameter		Ash	
		Chem-P	EBPR
Mass	<i>t/a</i>	5'519	4'889
Total solids (TS)	%	100	100
Volatile solids	% of TS	0	0
N	<i>g/kg TS</i>	0	0
P	<i>g/kg TS</i>	95	107
Fe	<i>g/kg TS</i>	152	51
Mg	<i>g/kg TS</i>	15	17
Al*	<i>g/kg TS</i>	50	50

Ca*	<i>g/kg TS</i>	100	100
Si*	<i>g/kg TS</i>	100	100
S*	<i>g/kg TS</i>	10	10
Cd	<i>mg/kg TS</i>	2.3	2.6
Cu	<i>mg/kg TS</i>	1'024	1'156
Cr	<i>mg/kg TS</i>	152	171
Ni	<i>mg/kg TS</i>	57	64
Pb	<i>mg/kg TS</i>	121	137
Hg	<i>mg/kg TS</i>	0.51	0.57
Zn	<i>mg/kg TS</i>	2'390	2'698

*Defined from Krüger and Adam 2014, *estimated by P-REX partners*

4.2 P recovery processes

Input data for P recovery processes is collected from technology providers and operators and transferred to the reference model. Data collection and transfer was organized in close contact with project partners, so that the respective datasets reflect the current status of processes at the time of data collection (year 2014). A summary of aggregated LCI data for all P recovery processes is provided in the annex (chapter 8.3).

4.2.1 P recovery from digested sludge or liquor

Input material, P recovery potential, and demand for electricity, heat, and chemicals is summarized below for P recovery processes from sludge or liquor (Table 4-3). For the individual processes, process data has been defined as follows:

- **Sludge precipitation (Airprex™):** P recovery ratio is defined based on P balances in full-scale plants in Berlin-Wassmannsdorf and Mönchengladbach (90% precipitation efficiency for dissolved PO₄-P, 50% harvesting of formed struvite crystals into the product). Electricity demand is calculated in relation to aeration time (8h). MgCl₂ is dosed in molar excess to dissolved PO₄-P (ratio 2.1). Based on operators experience, dewatering of output sludge is improved by +2% TS (mean), and polymer demand can be reduced by 25%.
- **Liquor precipitation 1 (Pearl®):** Process data is based on the Rock Creed plant (US), assuming a recovery of 83% of total P load in the liquor into the final product. Electricity demand is mainly for recirculation pump, while heat is used for product drying in belt drier. MgCl₂ is dosed in equimolar ratio to P, and NaOH is used for pH control.
- **Liquor precipitation 2 (Struvia™):** P recovery ratio is calculated from pilot plant results in Brussels to 80% of total P load in the liquor into the final product. Electricity

demand is estimated by the provider to 0.2 kWh/m³ liquor mainly for turbomix, while heat is used for product drying. Equimolar Mg dosing and NaOH for pH control are defined comparable to the Pearl® process, as both processes use the same principle.

- **Sludge leaching 1 (Gifhorn):** Process data is based on extensive studies of the Gifhorn full-scale plant with EBPR sludge. P recovery potential is calculated by overall P balances to 48.7% related to the total P load in sludge, assuming an extraction pH of 4.5 and related demand of H₂SO₄. Mg is dosed as Mg(OH)₂ below stoichiometric ratio, because the majority of P is precipitated as calcium phosphate. NaOH demand for pH control is based on a final pH of 9.3, and Na₂S demand is directly taken from Gifhorn data. Electricity demand for the entire process is based on detailed engineering of all aggregates (pumps, mixers, dosing), including the second centrifuge for dewatering. Additional polymer demand for second dewatering is assumed with 2 g/kg TS.
- **Sludge leaching 2 (Stuttgart):** P recovery potential is calculated to 45% based on latest experience (Feb 2015) at the large pilot plant in Offenburg working on ChemP sludge, assuming an extraction pH of 4 with respective dosing of H₂SO₄. Masking of metals is realized with citric acid (4 L/m³ filtrate). Mg dosing is equimolar to dissolved PO₄-P after extraction to precipitate P mainly as struvite at pH = 8.5, adjusted with NaOH. Electricity demand is for mixing and dosing of chemicals only, without a second dewatering unit (sedimentation of product).

For product quality (P content, heavy metals), original samples of full-scale or pilot plants have been measured within P-REX (D8.1), but also in monitoring campaigns of operators. Resulting product quality is documented below for the LCA model (chapter 4.2.3).

For estimating infrastructure of P recovery processes and related material demand, a simplified approach is used based on estimates for the most material-intensive system parts (e.g. tanks, reactors). Usually, infrastructure plays only a minor role in LCA of water or sludge treatment processes due to the long lifetime (> 20a) of equipment, reducing the impact of infrastructure in comparison to annual operational efforts to <5%. However, estimates for material-intensive parts are calculated based on reactor size and material type to approximate the LCA impacts of infrastructure. Infrastructure data can be found for all processes in Table 8-1.

Table 4-3: Inventory of P recovery processes from sludge and liquor

Parameter		Sludge preci- pitation	Liquor preci- pitation 1	Liquor preci- pitation 2	Sludge leaching 1	Sludge leaching 2
Reference system		EBPR	EBPR	EBPR	EBPR	ChemP
Input material		Digested sludge	Liquor	Liquor	Digested sludge	Digested sludge
P recovery¹	%	7.2	11.8	11.4	48.7	45
Electricity²	<i>kWh/m³</i>	0.92	0.36	0.2	4.2	2.7
Heat	<i>kWh/kg P_{out}</i>	-	1.8	0.9	-	-
MgCl₂ (30%)	<i>L/m³</i>	3.4	1.3	1.3	-	-
	<i>Mg/P³</i>	2.1	1	1		
Mg(OH)₂ (53%)	<i>L/m³</i>	-	-	-	0.2	-
	<i>Mg/P³</i>				0.1	
MgO (100%)	<i>kg/m³</i>	-	-	-	-	1
	<i>Mg/P³</i>					1
NaOH (50%)	<i>L/m³</i>	-	0.04	0.04	2.3	2.0
H₂SO₄ (78%)	<i>L/m³</i>	-	-	-	3.7	5
Na₂S (15%)	<i>L/m³</i>	-	-	-	2.7	-
Citric acid (50%)	<i>L/m³</i>	-	-	-	-	3.6
Dewatering		+2% TS	-	-	-	-
Polymer demand		-25%	-	-	+1%	-

Concentration of chemicals as Mass-%, related to m³ input (sludge or liquor)

¹ related to total P load in raw sludge (= 100%)

² related to input flow (sludge or liquor)

³ molar ratio between Mg and dissolved PO₄-P

4.2.2 P recovery processes from dried sludge or ash

Input material, P recovery potential, and demand for electricity, heat, fuels, and chemicals is summarized below for P recovery processes from ash or sludge (metallurgic) (Table 4-4). For the individual processes, process data has been defined as follows:

- **Sludge metallurgic (Mephrec®):** Process data is based on modelling data of Ingitec for a full-scale plant (12000 t TS/a). 80.5% of input P can be recovered in the slag,

accounting for some losses in metal alloy and off-gas. Electricity demand for Mephrec reactor is estimated with 0.05 kWh/kg input material, while briquetting requires 0.035 kWh/kg briquettes. Electricity and heat demand for sludge drying to 80% TS upstream of Mephrec reactor has been assumed from other studies (0.09 kWh/kg evaporated H₂O for electricity, 0.875 kWh/kg evaporated H₂O for heat). Heat for drying is partially supplied by excess heat from off-gas energy recovery in ORC (“stand-alone”) or completely by excess heat of MSWI plant. Electricity output is based on electrical efficiency of ORC process (13%) or MSWI steam turbine (20%) in relation to heating value of Mephrec off-gas. Coke and oxygen demand of the furnace is estimated based on thermal simulation of reactor. Beside the P-rich slag, an iron alloy can also be recovered from the process.

- **Ash metallurgic (Mephrec®):** Process data is similar to the sludge-based process, assuming electricity demand for briquetting, Mephrec reactor and off-gas cleaning to 0.09 kWh/kg input material. Coke and oxygen demand are estimated by thermal simulation.
- **Ash leaching 1 (Leachphos):** Process data is based on large pilot trials in Basel and complemented with lab results at FHNW, estimating a P recovery potential of 70.1% of P content in input ash into the final P product. Electricity demand is estimated based on detailed engineering of the process (mixing, pumping) and dewatering steps. Chemical demand for acidic leaching (H₂SO₄) and pH increase (Ca(OH)₂, NaOH) is based on pilot results and includes treatment of acidic leachate after product separation.
- **Ash leaching 2 (Ecophos):** This data is based on previous experience of Ecophos with mono-incineration ashes and represents planning data of a full-scale plant. Demand for electricity, steam (for product concentration), and HCl are based on Ecophos estimates, while ion exchange resin is changed every 2a. By-products of the purification process are accounted as CaCl₂ and FeCl₃ solution.
- **Ash thermo-chemical (Ash Dec):** Process data is based on pilot trials with mono-incineration ash and thermal simulation of the process (ASPEN software). P losses with off-gas are estimated to 2%. Electricity demand for the rotary kiln and off-gas cleaning is assumed with 0.104 kWh/kg ash. Drying of a fraction of sludge (6% of total TS) as reducing agent is included in the data with additional electricity and heat demand (natural gas). Heating of input ash and rotary kiln is realized with natural gas burning, while integration of Ash Dec with an existing mono-incineration eliminates gas demand for ash heating. Dosing of NaSO₄ is transferred from pilot plant results, while off-gas cleaning requires Ca(OH)₂ and NaOH (estimate from BAT dry gas cleaning).

Table 4-4: Inventory of P recovery processes from dried sludge and ash

Parameter		Sludge metallurgic ¹	Ash metallurgic	Ash leaching 1	Ash leaching 2	Ash thermo- chemical ⁵
Reference system		ChemP	ChemP	ChemP	EBPR	EBPR
Input material		Dried sludge	Ash	Ash	Ash	Ash
P recovery²	%	80.5	80.5	70.1	97	98
Electricity demand³	kWh/kg	0.36/0.3 ⁴	0.09	0.11	0.03	0.14/0.12 ⁶
Electricity output³	kWh/kg	0.32/0.45 ⁴	-	-	-	-
Heat demand⁷	kWh/kg	0.6/0 ⁴	-	-	-	0.26
Natural gas	kWh/kg	-	-	-	-	0.06/0.04 ⁶
Coke	kWh/kg	0.7	1.5	-	-	-
Steam	kg/kg	-	-	-	3	-
Ca(OH)₂ (100%)	kg/kg	-	-	0.26	-	0.015
H₂SO₄ (78%)	L/kg	-	-	0.28	-	-
NaOH (50%)	L/kg	-	-	0.05	-	0.014
HCl (37%)	L/kg	-	-	-	0.9	-
NaSO₄ (100%)	kg/kg	-	-	-	-	0.37
Dolomite (100%)	kg/kg	0.04	-	-	-	-
O₂ (liquid)	kg/kg	0.023	0.032	-	-	-
Ion exchange resin	g/kg	-	-	-	0.29	-
Product: Fe slag	kg/kg	0.057	0.146	-	-	-
Product: CaCl₂ (100%)	kg/kg	-	-	-	0.67	-
Product: FeCl₃ (40%)	kg/kg	-	-	-	0.41	-

Concentration of fuels and chemicals as Mass-%, related to input (dried sludge briquettes (14kt/a) or ash)

¹ including sludge drying(80% TS)

² related to total P load in raw sludge (= 100%)

³ related to input flow (sludge or liquor)

⁴ for integrated option in MSWI plant

⁵ including partial drying of 6% of sludge as reducing agent

⁶ for integrated option with mono-incineration plant

⁷ for sludge drying, covered by additional natural gas

Infrastructure materials for P recovery from dried sludge or ash is estimated with assumptions from technology providers and summarized in Table 8-2.

4.2.3 Quality of recycled P products

The quality of the recovered P products is defined in terms of heavy metal content to estimate potential toxicity of inorganic contaminants if applied as mineral fertilizer. However, relative transfer factors from input material quality (i.e. heavy metal content in sludge, liquor, or ash) into the product are not available for most processes, as mass balances of heavy metals cannot be closed due to lack of data. Data collection provided existing analysis of grab samples from providers and new data from product sampling and analysis in P-REX (D8.1). Finally, it has been decided to report product qualities based on average quality of existing products (Table 4-5). Hence, direct relation with heavy metal content in the reference input sludge or ash is not possible, but the heavy metal content of products is expected to be representative of typical outputs from the different process types. For liquor precipitation (Pearl® and Struvia™), comparable quality of products has been assumed, as well as for metallurgic treatment of sludge or ash. Quality of the Ecophos product is estimated based on process provider data.

Table 4-5: Heavy metal content of P products

[mg/kg P]	Sludge precipitation	Liquor precipitation 1+2	Sludge leaching 1	Sludge leaching 2	Sludge or ash metallurgic	Ash leaching 1	Ash leaching 2	Ash thermo-chemical
Cadmium	2	0.8	2	4	6	30	1.6*	5
Chromium	144	21	14	42	2'500	261	5	1'600
Copper	371	20	104	303	2'626	6'511	5	10'249
Mercury	2	3	2	3	15	1.5	1.6*	4
Nickel	139	19	15	47	389	106	1.6*	580
Lead	109	10	9	64	95	193	1.6*	797
Zinc	785	113	215	470	1'944	10'636	3	24'428

* below limit of quantification (LOQ), estimated as LOQ/2

4.3 Background processes

4.3.1 Energy, chemicals, materials, transport

Background processes of sludge line and P recovery are modelled with datasets from ecoinvent v3.1 database (Ecoinvent 2014) as described below (Table 4-6). Market datasets are used for all materials and chemicals as available. If no market data is available, production data is used and an additional transport by truck (200km) for the delivery to the plant is assumed.

Table 4-6: Ecoinvent datasets for background processes

Material	Ecoinvent v3.1 dataset	Remarks
Electricity	<i>electricity, high voltage, production mix [DE]</i>	Mix of Germany 2010
Heat	<i>market for heat, district or industrial, natural gas [EU]</i>	For sludge drying
Natural gas	<i>natural gas, high pressure, at consumer [DE]</i>	
Steam	<i>steam production, in chemical industry [RER]</i>	
Coke	<i>market for coke [GLO]</i>	
O ₂	<i>market for oxygen, liquid [RoW]</i>	
MgCl ₂	<i>heat production, natural gas, at industrial furnace >100kW [EU]</i>	1'100 MJ/m ³ MgCl ₂ (30%)
Mg(OH) ₂	<i>market for sodium hydroxide, without water, in 50% solution state [GLO], heat production, natural gas, at industrial furnace >100kW [EU]</i>	Mixture of NaOH and MgCl ₂
MgO	<i>market for magnesium oxide [GLO]</i>	
H ₂ SO ₄	<i>market for sulfuric acid [GLO]</i>	
HCl	<i>market for hydrochloric acid, without water, in 30% solution state [RER]</i>	
NaOH	<i>market for sodium hydroxide, without water, in 50% solution state [GLO]</i>	
N ₂ S	<i>sodium sulfite production [RER]</i>	+ transport (200km)
Citric acid	<i>citric acid production [RER]</i>	+ transport (200km)
Ca(OH) ₂	<i>market for lime, hydrated, loose weight [GLO]</i>	
Dolomite	<i>dolomite production [RER]</i>	+ transport (200km)
NaSO ₄	<i>market for sodium sulfate, anhydrite [RER]</i>	
Ion exchange resin	<i>cationic resin production [CH]</i>	
Concrete	<i>market for concrete, normal [GLO]</i>	Density: 2'000 kg/m ³
Reinforcing steel	<i>market for reinforcing steel [GLO]</i>	
Stainless steel	<i>market for metal working, average for chromium steel product manufacturing [GLO]</i>	
Transport	<i>transport, freight, lorry 16-32 metric ton, EURO5 [RER]</i>	
Hazardous waste	<i>treatment of hazardous waste, underground deposit [DE]</i>	For final disposal of mono-incineration ash
Inert waste	<i>treatment of inert waste, inert material landfill [CH]</i>	For inert waste

CH: Switzerland, DE: Germany, EU: European Union, RER: Europe, GLO: Global, RoW: Rest of World

Some datasets have been modified or recalculated in the following way:

- MgCl_2 : Production of MgCl_2 is assumed using waste brine from salt production, accounting for energy demand for concentration ($1100 \text{ MJ/m}^3 \text{ MgCl}_2$ (30%))
- Mg(OH)_2 : as no dataset for Mg(OH)_2 is available in ecoinvent, it is assumed that $1 \text{ m}^3 \text{ Mg(OH)}_2$ (53%) is produced from $1.6 \text{ m}^3 \text{ NaOH}$ (50%) and $3.8 \text{ m}^3 \text{ MgCl}_2$ (30%).

4.3.2 Credits for substituted products

For products and by-products of sludge line (electricity from CHP plant), mono-incineration (electricity and district heating) and P recovery processes (mineral P and N fertilizer, by-products from Mephrec and Ecophos), the substitution of equivalent products is accounted as credit in this LCA (Table 4-7).

Table 4-7: Ecoinvent datasets for substitution of products and by-products

Material	Ecoinvent v3.1 dataset	Remarks
Electricity	<i>electricity, high voltage, production mix [DE]</i>	German energy mix 2010
Heat	<i>market for heat, district or industrial, natural gas [EU]</i>	For district heating
P fertilizer	<i>market for phosphate fertiliser, as P2O5 [GLO]</i>	For all P products
N fertilizer	<i>market for nitrogen fertiliser, as N [GLO]</i>	For struvite (5.7% N)
Iron alloy	<i>market for iron scrap, unsorted [GLO]</i>	From Mephrec process
CaCl_2	<i>market for calcium chloride [GLO]</i>	From Ecophos process
FeCl_3	<i>iron (III) chloride production, product in 40% solution state [CH]</i>	From Ecophos process

CH: Switzerland, DE: Germany, EU: European Union, RER: Europe, GLO: Global

Mineral P fertilizer contains heavy metals, which will end up in the agricultural soil after application on farmland. This type of direct emission of P fertilizer application is not reflected in the respective ecoinvent dataset of P fertilizer production. Consequently, this LCA assumes a direct input of heavy metals with mineral P fertilizer, which can be substituted with secondary P products. Heavy metal content of an average mineral P fertilizer has been defined as 17.5 mg Cd, 237 mg Cr, 40 mg Cu, 38 mg Ni, 0.13 mg Hg, 29 mg Pb, and 367 mg Zn per kg P (Remy 2010). Mineral N fertilizer is assumed to contain no heavy metals.

5 Life Cycle Impact Assessment

Results of Life Cycle Impact Assessment are presented and discussed in this chapter. All indicators are evaluated separately for the total environmental impacts that can be allocated to P recovery in the different scenarios, quantifying the impacts in relation to the respective baseline scenario (Ref_EBPR or Ref_ChemP) with the “system change” perspective (cf. chapter 3.2). For selected indicators (fossil energy demand, global warming, and toxicity), results are also discussed in relation to the total recovery potential for P, relating to the total amount of P in the input sludge. For fossil energy demand and global warming, impacts are also related to the amount of recovered P, using the “product perspective” (cf. chapter 3.2) to discuss the footprint of the individual P products. In these graphs, closed symbols relate to scenarios with ChemP sludge as input, whereas open symbols show scenarios with EBPR sludge as input.

Finally, all indicator results are normalized to enable a wider view on all impacts in relation to total environmental impacts in EU27 countries. The chapter closes with a short sensitivity analysis, checking the influence of baseline definitions (i.e. analysing co-incineration as option for disposal), indicator choice for toxicity modelling, and variation of input data (i.e. dissolved P content in sludge, and increase in dewatering in sludge precipitation).

5.1 Cumulative energy demand

Total CED_{fossil} of P recovery from sludge or liquor shows a wide variation between -9.5 and +51.6 Mio MJ/a (Figure 5-1). Whereas P recovery via sludge precipitation (-9.5 Mio MJ/a) or liquor precipitation (-4.8-5.0 Mio MJ/a) enables energy savings compared to the baseline, both options for sludge leaching increase the total fossil energy demand substantially (24.1-51.6 Mio MJ/a).

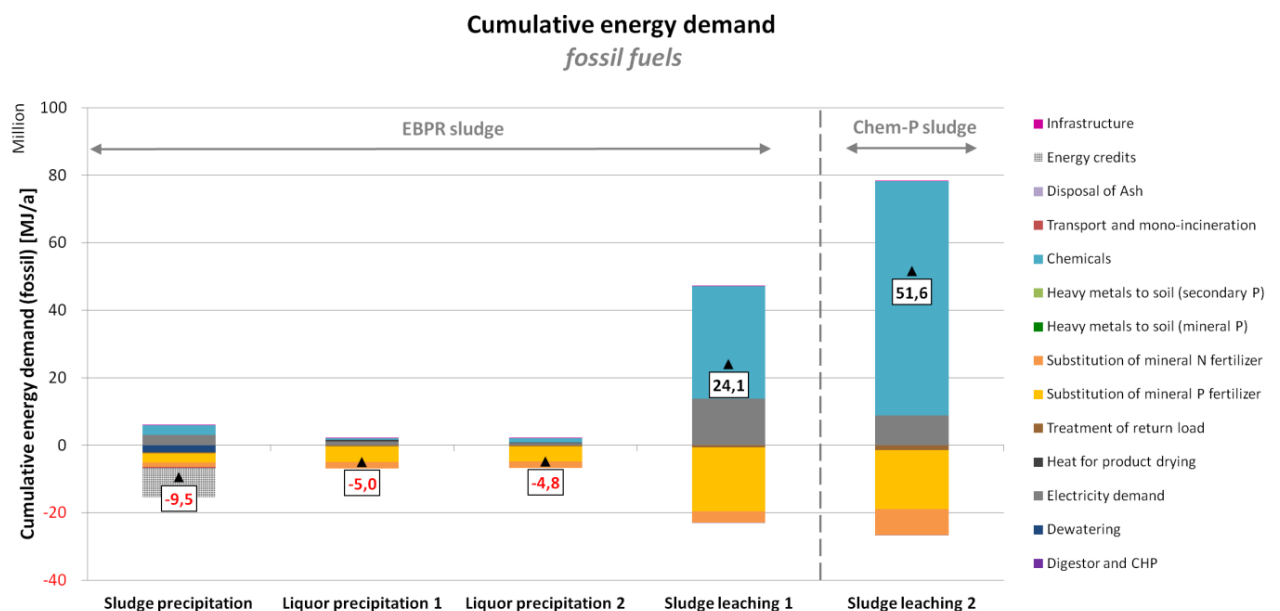

Figure 5-1: Total cumulative energy demand (fossil) of P recovery from sludge or liquor

For sludge precipitation, additional efforts in energy and chemical demand are neutralized by energy savings from substituted fertilizer production, but also by high energy credits from

polymer savings and improvements in dewaterability of digested sludge, which enable a better energy recovery in mono-incineration. As these effects on dewaterability are difficult to quantify and may vary between WWTPs, this parameter is further analysed in sensitivity analysis (chapter 5.9.4). Both options of liquor precipitation are characterized by very low efforts in chemicals and energy, which results in overall savings due to fertilizer substitution credits. For sludge leaching options, high chemical demand of leaching and subsequent pH increase leads to high efforts in fossil energy, which cannot be neutralized by fertilizer credits. This effect is more pronounced if ChemP sludge is used as input material, most probably because P solubilisation is more difficult with high Fe content and requires additional acid and neutralizing caustic.

Fossil energy demand for P recovery from dried sludge or ash ranges between -26 and +27.9 Mio MJ/a (Figure 5-2). Metallurgic treatment of sludge requires high amounts of energy (as electricity and coke) for the furnace process, but also a large amount for sludge drying. If metallurgic sludge treatment is built “stand-alone”, energy credits from fertilizer substitution and energy recovery from off-gas cannot off-set energy demand for furnace and sludge drying, leading to an additional need of energy (27.9 Mio MJ/a). The integrated option can decrease the energy demand for sludge drying substantially by supplying excess heat from the MSWI plant, also improving the efficiency of energy recovery from furnace off-gas, leading to an overall savings in fossil energy demand (-26 Mio MJ/a). Ash treatment in the metallurgic process requires less energy for furnace operation, but has no energy recovery option from the off-gas. Overall, metallurgic ash treatment can also save fossil energy demand (-14.5 Mio MJ/a).

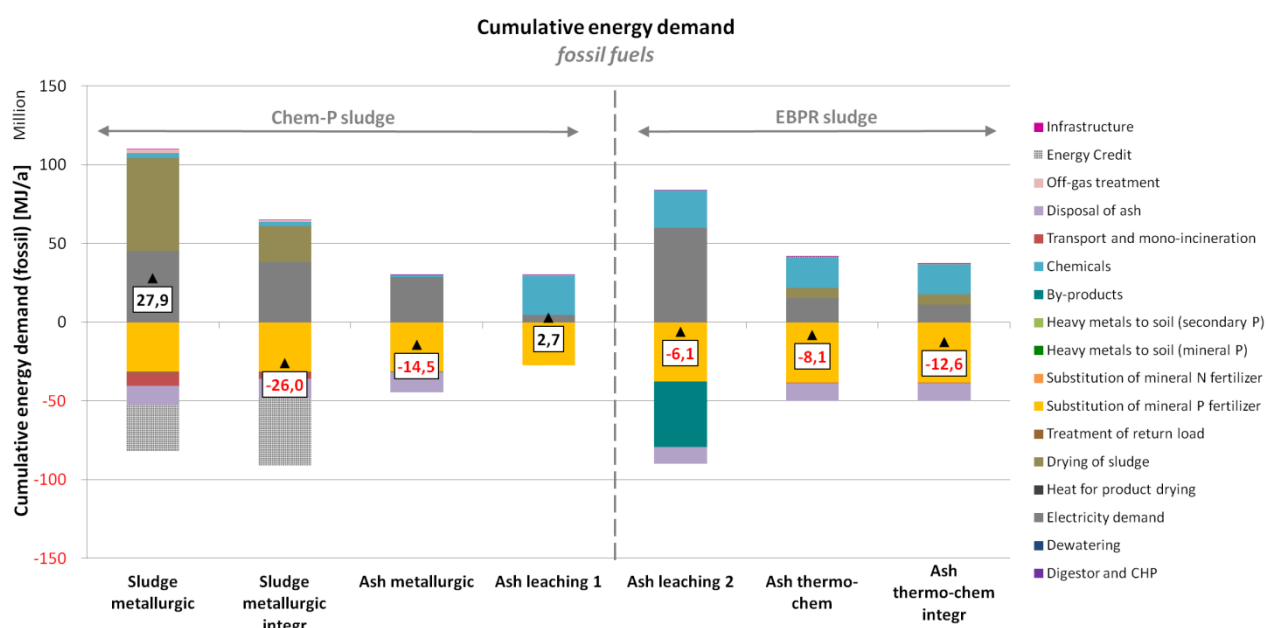

Figure 5-2: Total cumulative energy demand (fossil) of P recovery from dried sludge or ash

Fossil energy demand of ash leaching 1 of ChemP ash (Leachphos) is dominated by chemical demand for leaching and product precipitation. This energy demand is partly neutralized by fertilizer credits, leaving a final energy demand of 2.7 Mio MJ/a for this option. In comparison, the Ecophos process (ash leaching 2) needs higher amounts of energy mainly for steam

production, but this is completely neutralized by credits for fertilizer and by-products, resulting in net energy savings for this process (-6.1 Mio MJ/a).

Thermo-chemical treatment of ash needs energy for chemicals (mainly NaSO₄) and heating of ash and rotary kiln, plus some energy for drying of sludge as reducing agent. Overall, fertilizer credits and avoided disposal of ash leads to an overall negative energy demand (-8.1 Mio MJ/a) which can be further decreased by integration into an existing mono-incineration plant, saving on natural gas for ash pre-heating (-12.1 Mio MJ/a).

Looking at the net demand for fossil energy of all P recovery options in relation to their P recovery potential, it becomes obvious that the pathways and technologies for P recovery show a wide variety in energy footprint and also P recovery potential (Figure 5-3). Whereas P recovery via precipitation in sludge and liquor yields energy savings, the P recovery potential of these pathways is limited to 7-12% of total P in sludge. Sludge leaching enables a recovery of 45-49%, but has a relatively high energy demand due to the chemicals required for leaching. The energy footprint of ash leaching depends on the technology, with Leachphos at 70% P recovery and a small additional energy demand, whereas Ecophos has a higher P recovery potential (97%) and enables energy savings. Thermo-chemical treatment of ash can recover the maximum amount of P in this study (98%) and also saves on fossil energy demand. The direct metallurgical P recovery from sludge has either a highly positive or highly negative fossil energy demand depending on the type of integration that can be realized, yielding a P recovery of 81%. Metallurgic ash treatment has a comparable P recovery potential and a negative energy footprint.

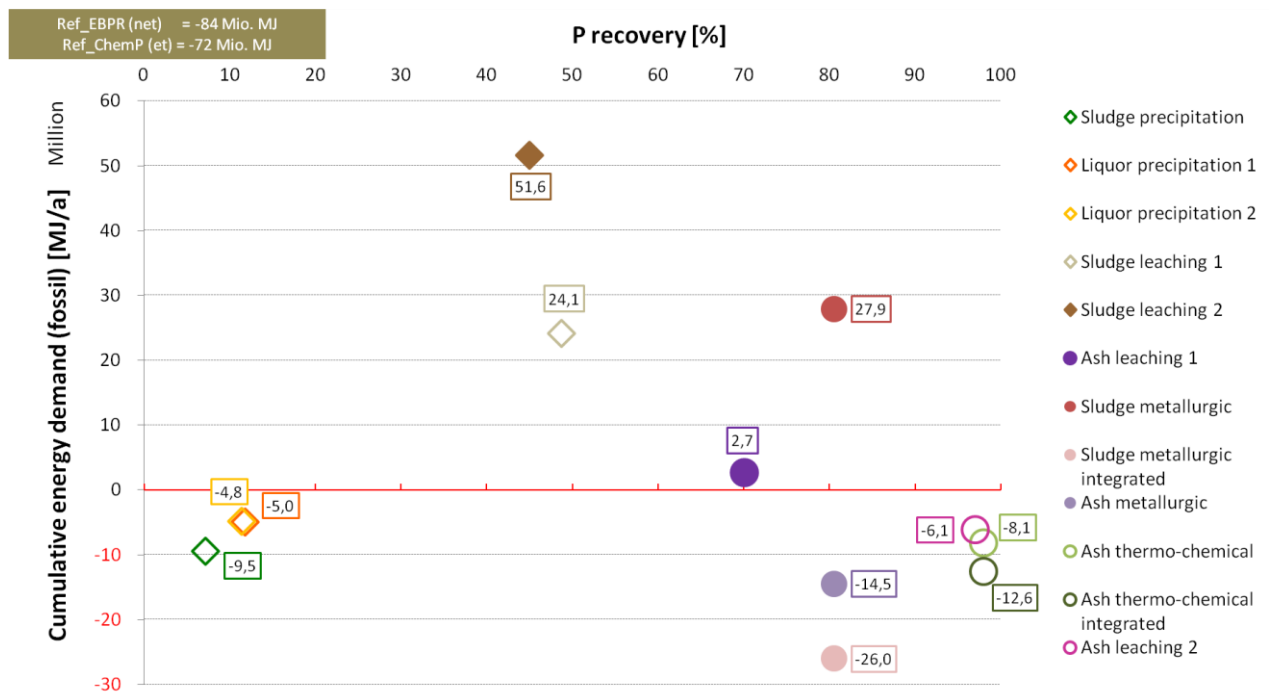

Figure 5-3: Total cumulative energy demand (fossil) related to P recovery potential

Compared to the overall CED_{fossil} of the reference sludge treatment line as 100% (-84 Mio MJ/a for Ref_EBPR and -72 Mio MJ/a for Ref_ChemP), P recovery can either save another 6-15% for EBPR or 20-36% for ChemP scenarios, or it will reduce energy savings by 29% for EBPR and 3-70% for ChemP. The latter option refers to the sludge leaching 2, which will off-set 70% of the energy credits from sludge treatment and disposal due to implementing of P recovery.

Net fossil energy demand can also be related to the amount of recovered P, giving information about the energy footprint of the respective secondary P product (Figure 5-4). Naturally, options with low recovery potential and high savings due to side effects on return load or dewatering (sludge and liquor precipitation) have the products with the best footprints, saving -252 and -80 MJ per kg P, respectively. Sludge leaching products need 94-219 MJ/kg P, whereas ash products can be produced with -24 to -16 MJ/kg P in thermo-chemical processes and -12 to +7 MJ/kg P in ash leaching. Metallurgic products vary between -62 and +66 MJ/kg P depending on input material and type of integration.

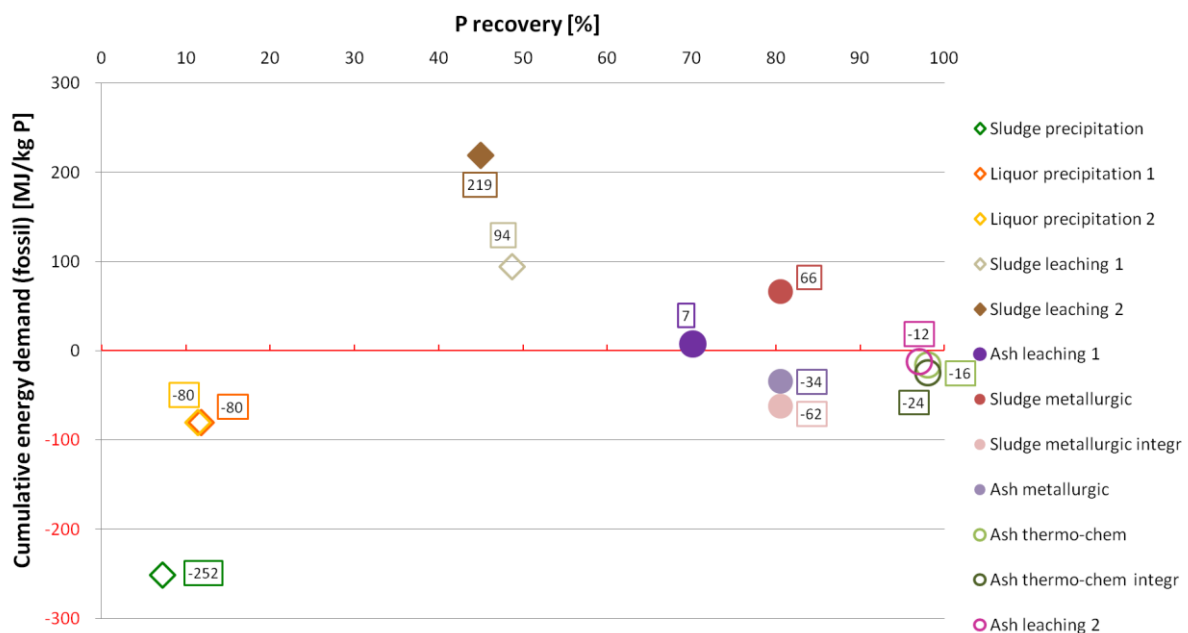

Figure 5-4: Cumulative energy demand (fossil) per kg P related to P recovery potential

Cumulative energy demand of nuclear fuels resembles the results of the fossil energy demand and is not discussed here in detail, but can be found in the annex (Figure 8-2 and Figure 8-3). Naturally, nuclear fuels are required only in electricity production, so that direct electricity consumption and chemicals production with high electricity use are dominant in this impact category. Net $CED_{nuclear}$ amounts to -0.6 Mio MJ/a for sludge precipitation, -0.5 to -0.3 Mio MJ/a for liquor precipitation, 6.5-9.8 Mio MJ/a for sludge leaching, -5.6 to -14.1 Mio MJ/a for metallurgic sludge treatment, -2.2 Mio MJ/a for metallurgic ash treatment, -1.8 to 0.1 Mio MJ/a for ash leaching, and 0.7-0.9 Mio MJ/a for thermo-chemical ash treatment.

5.2 Global warming potential

Global warming potential (GWP) is typically closely related to fossil energy demand, as greenhouse gases are mainly emitted from firing of fossil fuels. Hence, overall comparison between the processes is comparable to the results of CED_{fossil} . For P recovery from sludge or liquor, GWP is between -0.7 and +2.7 Mio kg CO₂-eq/a for the entire system (Figure 5-5). Sludge precipitation has a net GWP of -0.7 Mio kg CO₂-eq/a, off-setting electricity and chemicals demand with fertilizer credits and improved energy recovery in mono-incineration due to better dewatering. Liquor precipitation saves -0.6 Mio kg CO₂-eq/a due to low efforts in electricity/chemicals and high fertilizer credits. In general, credits for nitrogen fertilizer in struvite products are more significant for GWP, because direct emissions of N₂O during N fertilizer production are avoided.

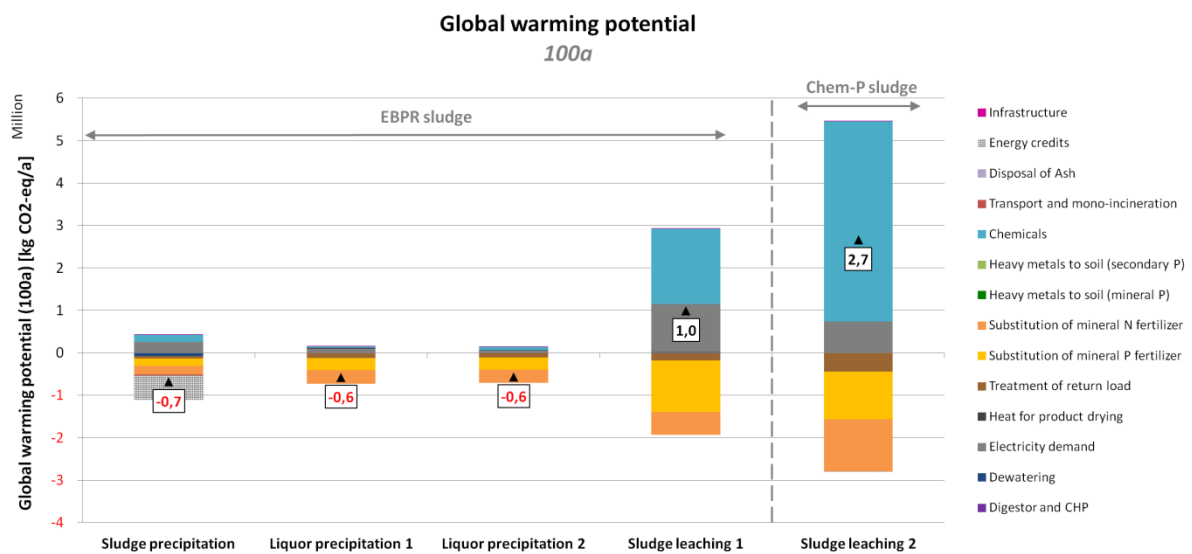

Figure 5-5: Total global warming potential (100a) for P recovery from sludge or liquor

Sludge leaching processes increase GWP by 1.0 or 2.7 Mio kg CO₂-eq/a with high chemical demand for leaching, although both options can realize substantial credits by fertilizer substitution. In addition, reducing the nitrogen return load has some positive effect as direct N₂O emissions in mainstream denitrification can be avoided.

P recovery options from dried sludge or ash have a net GWP of -3.4 to +1.1 Mio kg CO₂-eq/a (Figure 5-6). Metallurgic treatment of sludge has a slightly positive GWP of -0.3 Mio kg CO₂-eq/a, benefitting from high savings in N₂O emissions by avoiding fluidized bed mono-incineration with specifically high N₂O emissions. Consequently, the integrated option has the highest savings in GWP of all scenarios with -3.4 Mio kg CO₂-eq/a.

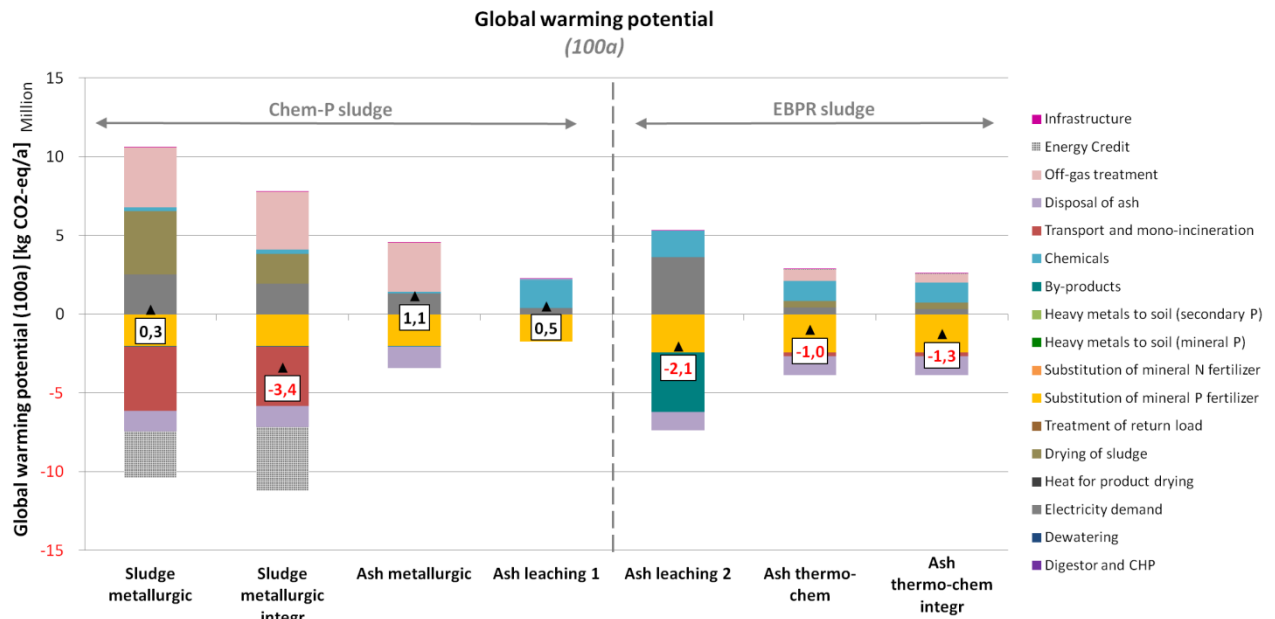

Figure 5-6: Total global warming potential (100a) for P recovery from dried sludge or ash

Metallurgic ash treatment has a positive GWP of +1.1 Mio kg CO₂-eq/a, mainly because coke for furnace heating causes high greenhouse gas emissions. Ash leaching with Leachphos process is nearly neutral in GWP (+0.5 Mio kg CO₂-eq/a), whereas the Ecphos process has a lower net GWP (-2.1 Mio kg CO₂-eq/a) due to by-products with high GWP credits. Thermo-chemical ash treatment decreases GWP by -1.0 Mio kg CO₂-eq/a for the stand-alone option and -1.3 Mio kg CO₂-eq/a for the integrated process.

Net GWP of all scenarios for P recovery related to their P recovery potential gives comparable results as for the fossil energy demand (Figure 5-7). Sludge and liquor precipitation have low P recovery potential and GWP savings, while sludge leaching leads to an increase in GWP with medium P recovery. Ash leaching has a higher potential for P recovery and a lower increase in GWP (Leachphos) or even GWP savings (Ecophos) depending on the process type. Thermo-chemical ash treatment has highest P recovery potential and also GWP savings, whereas metallurgic ash treatment has a comparatively high GWP. In contrast, metallurgic sludge treatment is nearly neutral or positive in GWP depending on process integration.

Compared to total net GWP of reference systems as 100% (-1.4 Mio kg CO₂-eq/a for Ref_EBPR and -0.3 Mio kg CO₂-eq/a for Ref_Chemp), P recovery scenarios can either increase existing GWP credits of sludge disposal by 43-150% for EBPR and 1130% for ChemP (the latter with factor 11 due to low credits in reference ChemP scenario) or decrease credits by 71% for EBPR and 100-800% for ChemP. In the latter scenarios, P recovery options will totally off-set any savings of GWP with sludge disposal and lead to total GWPs of 0 to 2.4 Mio kg CO₂-eq/a.

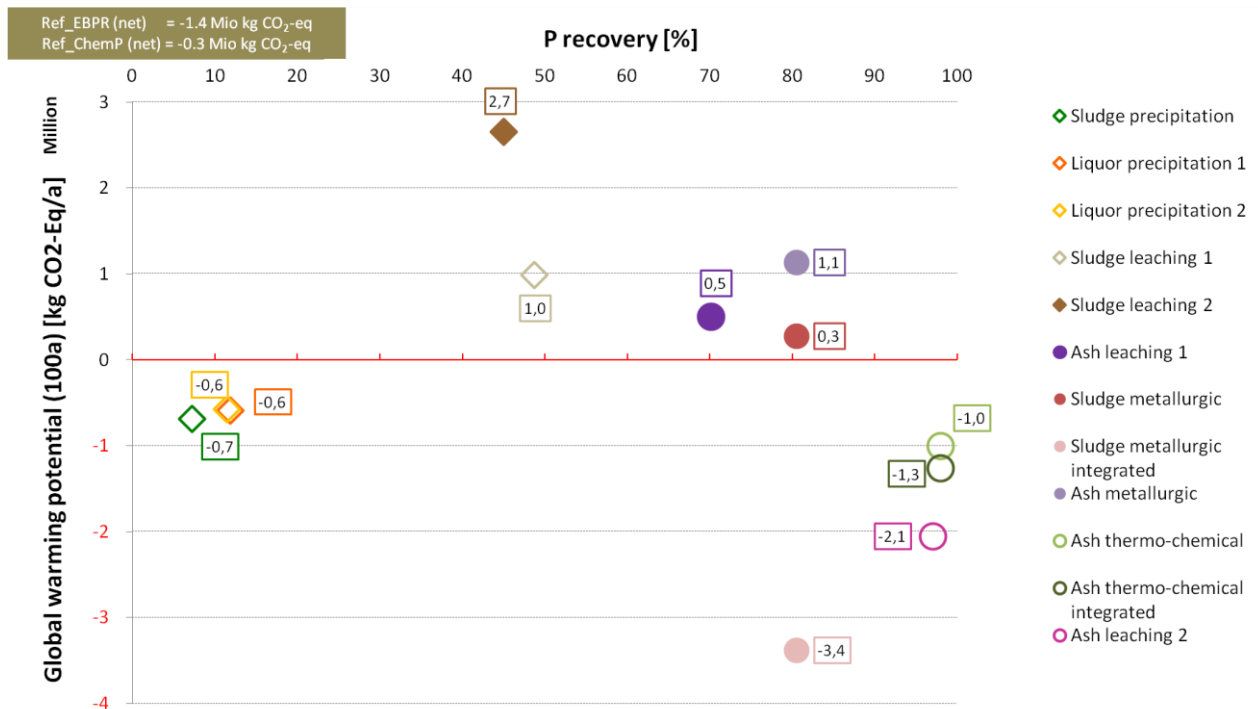

Figure 5-7: Total global warming potential (100a) related to P recovery potential

The same tendencies can be observed in the comparison of relative GWP of fertilizer products (Figure 5-8). Secondary P products from sludge or liquor precipitation come with high credits in GWP (savings of -18.2 to -9.5 kg CO₂-eq/kg P), making these products environmentally preferable for the customers. However, these processes have only a limited potential of P recovery (7-12%). Higher P recovery will lead to secondary P products with lower GWP credits or even additional GWP footprints between -8.0 and +11.3 kg CO₂-eq/kg P.

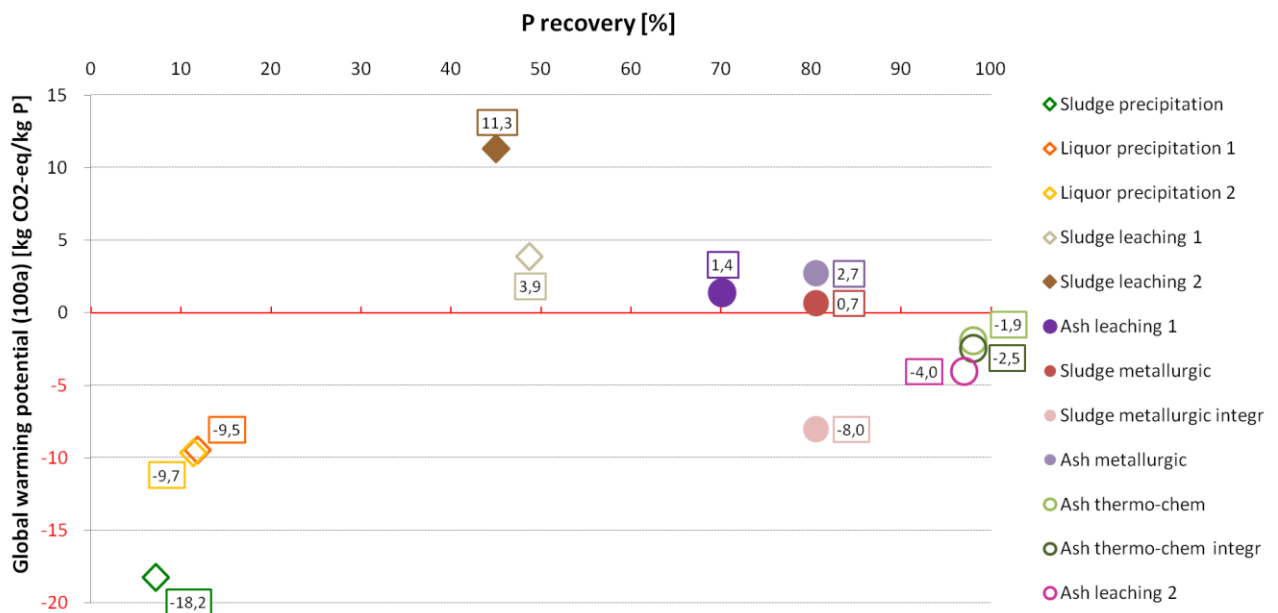

Figure 5-8: Global warming potential (100a) per kg P related to P recovery potential

5.3 Metal depletion potential

Metal depletion potential (MDP) of P recovery from sludge or liquor is between -0.07 and +0.18 Mio kg Fe-eq/a (Figure 5-9). Major impacts in this indicator are the credits for fertilizer substitution, but also chemical production. This leads to overall savings in MDP for sludge and liquor precipitation (-0.05 to -0.07 Mio kg Fe-eq/a) in contrast to additional MDP impacts in sludge leaching (+0.04 to +0.18 Mio Fe-eq/a). Although sludge leaching scenarios benefit from high credits due to fertilizer substitution, high efforts for chemical production completely off-set this credit. It has to be noted here that only metals are accounted in this resource indicator, whereas phosphate rock is not included in this impact category.

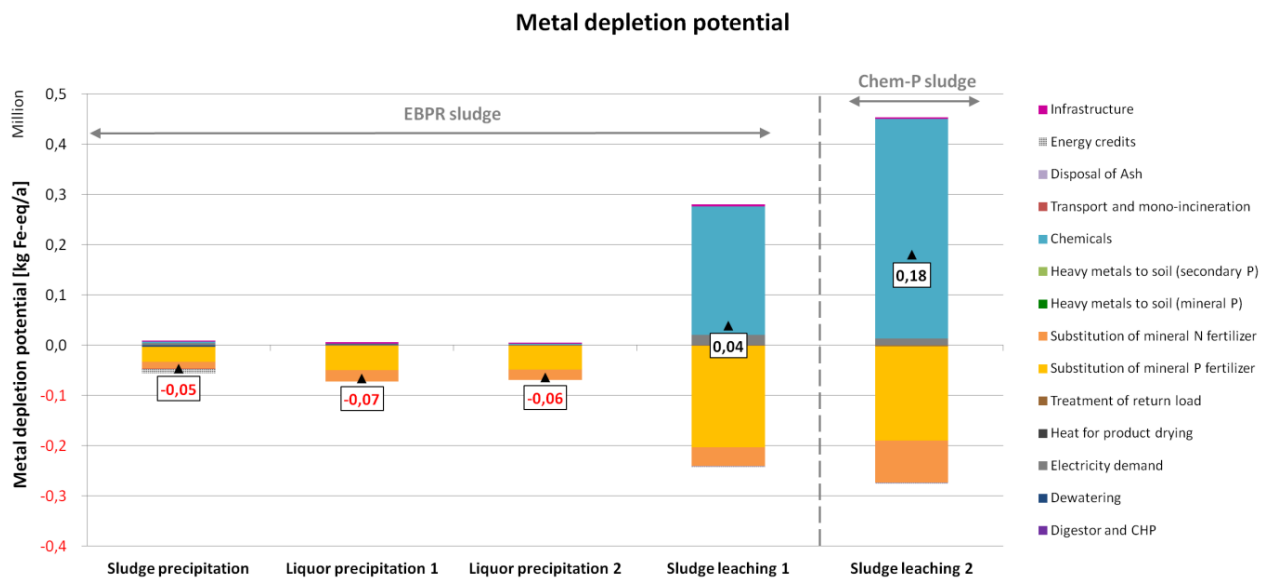

Figure 5-9: Total metal depletion potential of P recovery from sludge or liquor

For P recovery from dried sludge or ash, all options have a negative net MDP, ranging from -0.1 to -1.3 Mio Fe-eq/a (Figure 5-10). High credits for mineral fertilizer substitution, avoided ash disposal and by-products (e.g. FeCl_3 solution in Ecophos process) result in savings in this impact category.

5.4 Terrestrial acidification potential

Results for terrestrial acidification potential (TAP) are not discussed in detail here, as this environmental impact is not in the focus of this study. However, all results are provided in the annex (Figure 8-4 and Figure 8-5). In total, P recovery will lead to savings in TAP for sludge precipitation (-3.9 t SO_2 -eq/a) and liquor precipitation (-4.8 to -5.0 t SO_2 -eq/a), whereas sludge leaching increases TAP by 12.7-22.4 t SO_2 -eq/a. P recovery from dried sludge or ash will save TAP in all scenarios, accounting for -14.1 to -22.4 t SO_2 -eq/a for metallurgic sludge treatment, -20.3 t SO_2 -eq/a for metallurgic ash treatment, -0.6 to -47.1 t SO_2 -eq for ash leaching, and -22.3 to -22.5 t SO_2 -eq/a for thermo-chemical ash treatment.

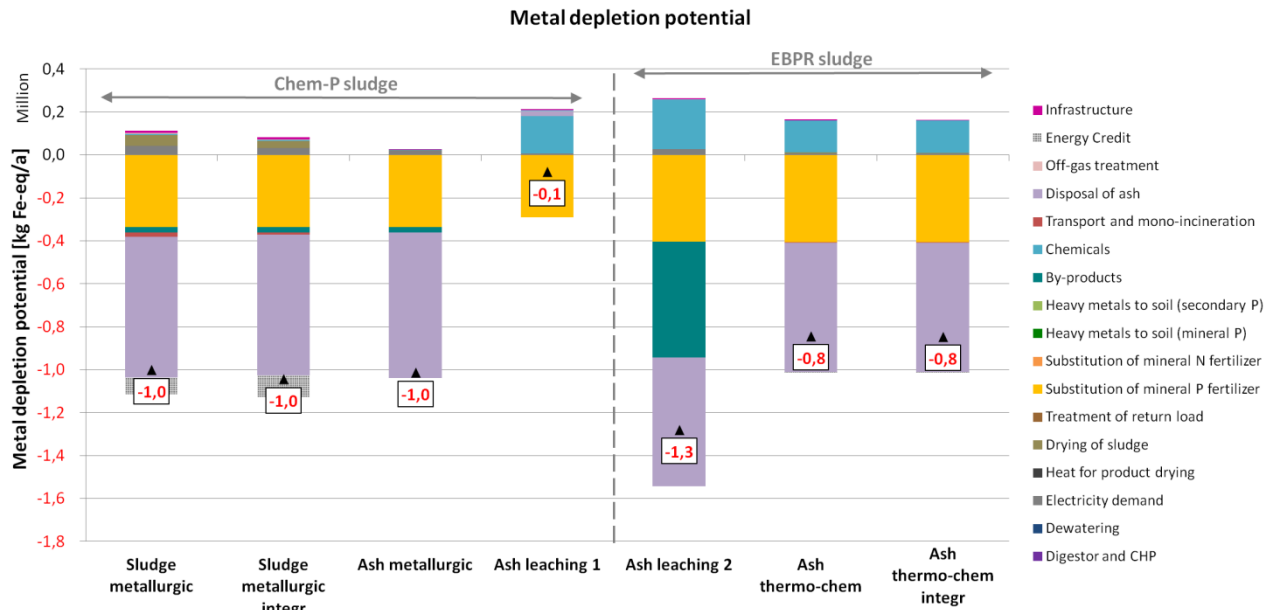

Figure 5-10: Total metal depletion potential of P recovery from dried sludge or ash

5.5 Eutrophication (freshwater and marine)

Freshwater eutrophication (FEP) is caused by phosphorus emissions, which can be reduced with all options for P recovery. Reduction in FEP is mainly related to substitution of mineral P fertilizer production (which is associated with P emissions into water), but also due to direct reduction of P emissions from the mainstream WWTP. The latter effect is a positive side-effect of recovering P from sludge or liquor in the EBPR scenarios, thus reducing the considerable P return load to the mainstream WWTP and consequently its direct P emissions. Hence, FEP can be reduced by -0.4 to -0.5 t P-eq/a with sludge or liquor precipitation, while sludge leaching from EBPR sludge can reduce FEP by -0.8 t P-eq/a (Figure 5-11). In contrast, reduction of return load is not effective for the ChemP scenario of sludge leaching, as this type of sludge does not lead to high concentrations of P in return load. Finally, sludge leaching 2 with ChemP sludge can reduce overall FEP by -0.2 t P-eq/a.

P recovery from dried sludge or ash does not directly affect return load of sludge dewatering, but major credits come from substitution of mineral P fertilizer production (Figure 5-12). In total, all options can substantially decrease FEP between -0.9 and -1.9 t P-eq/a. Some additional credits are due to energy recovery in metallurgic sludge treatment or through by-products in Ecophos, but these are mainly off-set by P emissions in background processes of energy and chemicals production. Overall, P recovery can contribute to a sustainable P management by reducing direct P emissions of WWTP processes and also indirect P emissions in mineral fertilizer production.

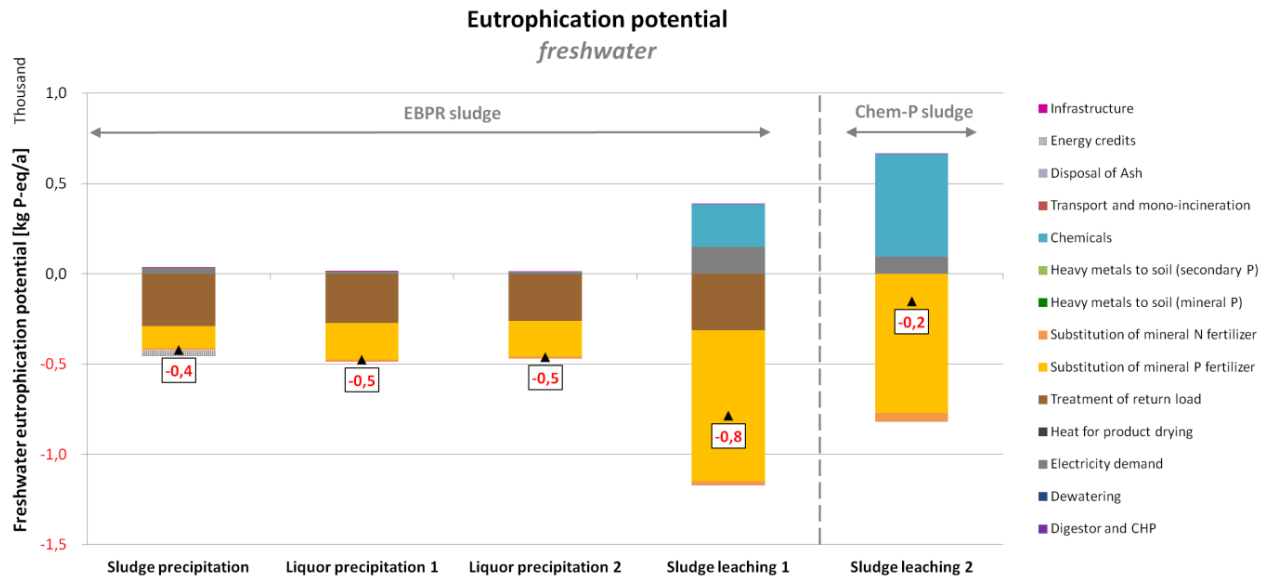

Figure 5-11: Total freshwater eutrophication potential for P recovery from sludge or liquor

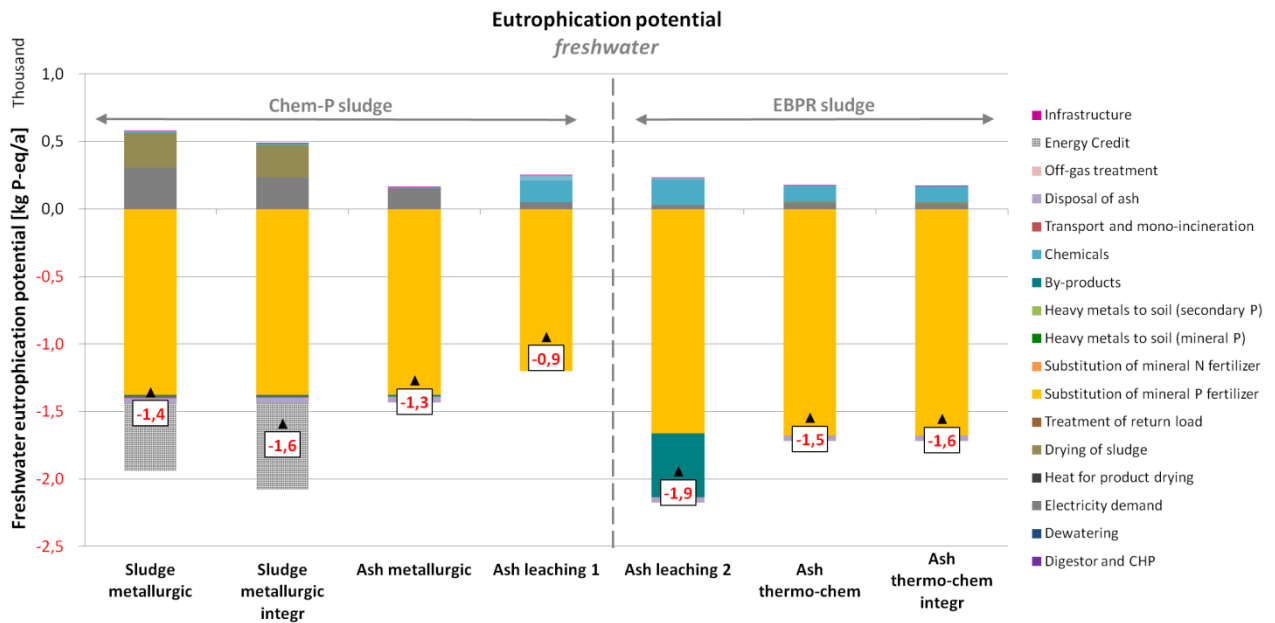

Figure 5-12: Total freshwater eutrophication potential for P recovery from dried sludge or ash

5.6 Ecotoxicity (freshwater)

Ecotoxicity (freshwater) of P recovery from sludge and liquor is between -2.0 and +10.0 Mio CTUe/a (Figure 5-13). In ecotoxicity evaluation, direct emissions of heavy metals with secondary or mineral fertilizer have a major impact on the results. For sludge precipitation, the struvite product is evaluated with higher ecotoxicity than mineral P, leading to an overall increase in ecotoxicity (+0.9 Mio CTUe/a). Struvite from liquor precipitation has lower heavy metal content, so that these options decrease ecotoxicity by -0.9 to -1.0 Mio CTUe/a. Sludge leaching also has a product with lower ecotoxicity scores than mineral P, which leads to negative net ecotoxicity for sludge leaching from EBPR sludge (-2.0 Mio CTUe/a). For sludge leaching from ChemP sludge,

indirect emissions during chemicals production are evaluated with high ecotoxicity here (mainly MgO), which gives an overall increase of 10 Mio CTUe/a in this scenario despite the good quality of the secondary P product.

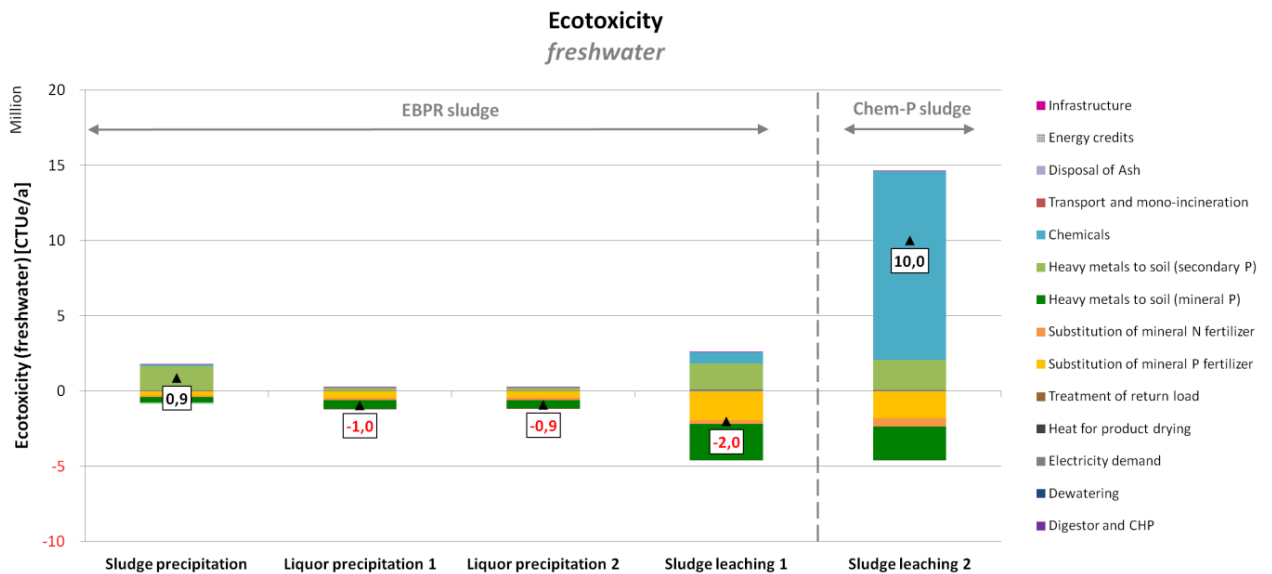

Figure 5-13: Total ecotoxicity (freshwater) of P recovery from sludge or liquor

Ecotoxicity (freshwater) of P recovery from dried sludge and ash is dominated by heavy metal content of secondary P products, leading to a substantial increase of +39 to +422 Mio CTUe/a for all processes except for Ecophos, where the good product quality yields an overall reduction in ecotoxicity (-10 Mio CTUe/a). Hence, all secondary P products from metallurgic or thermochemical treatment and also ash leaching in Leachphos are evaluated with considerably higher ecotoxicity than the substituted mineral P fertilizer.

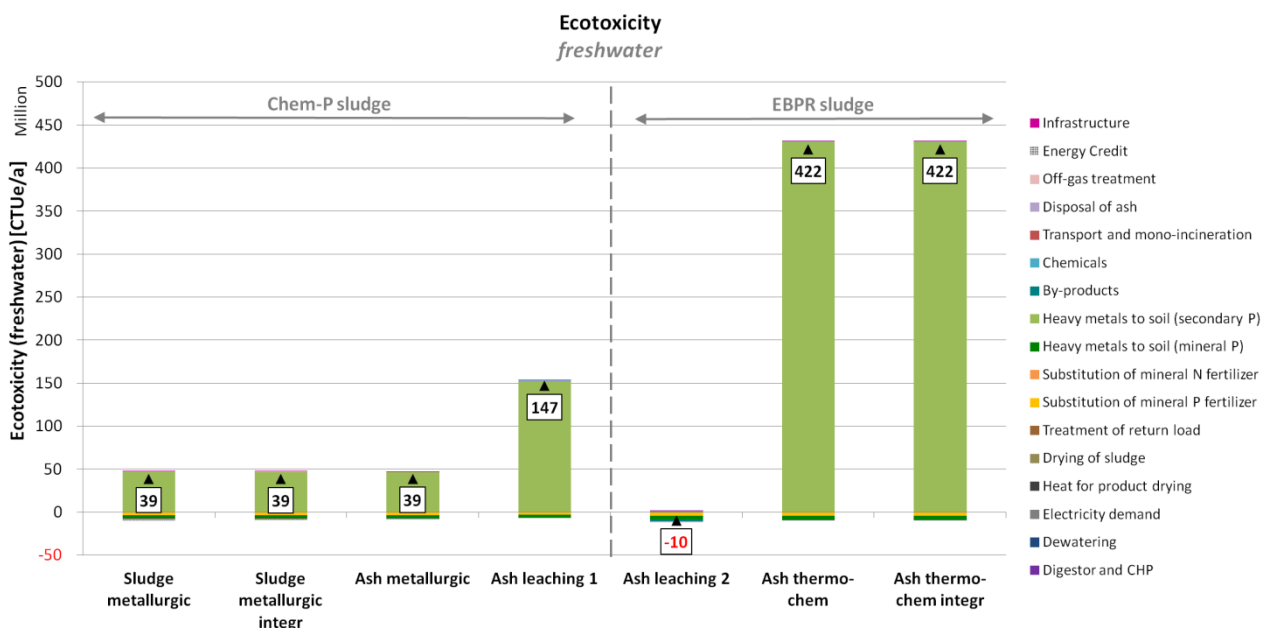

Figure 5-14: Total ecotoxicity (freshwater) of P recovery from dried sludge or ash

Assessing the individual metals, it becomes obvious that high Zn and Cu content in P products is responsible for the majority of this effect (>95%), as these metals have a relatively high characterization factor for ecotoxicity. However, Cu and Zn are also considered as micro-nutrients from the perspective of agriculture, and the real harmful effects on aquatic organisms may be overestimated by the global USEtox® model with interim characterization factors. For further analysis of this effect, alternative indicators for ecotoxicity are calculated and discussed below (chapter 5.9.2).

Comparing total net ecotoxicity of all scenarios (Figure 5-15), sludge and liquor products are associated with low ecotoxicity compared to mineral fertilizer, whereas some products from ash or metallurgic sludge treatment cause high ecotoxicity, especially for thermo-chemical ash treatment and ash leaching with Leachphos. However, processes with high P recovery and low heavy metal content are also available (e.g. Ecophos). Existing ecotoxicity of sludge disposal in incineration is marginal (0.5-0.7 Mio CTUe/a) compared to additional impacts of mineral or secondary fertilizer products.

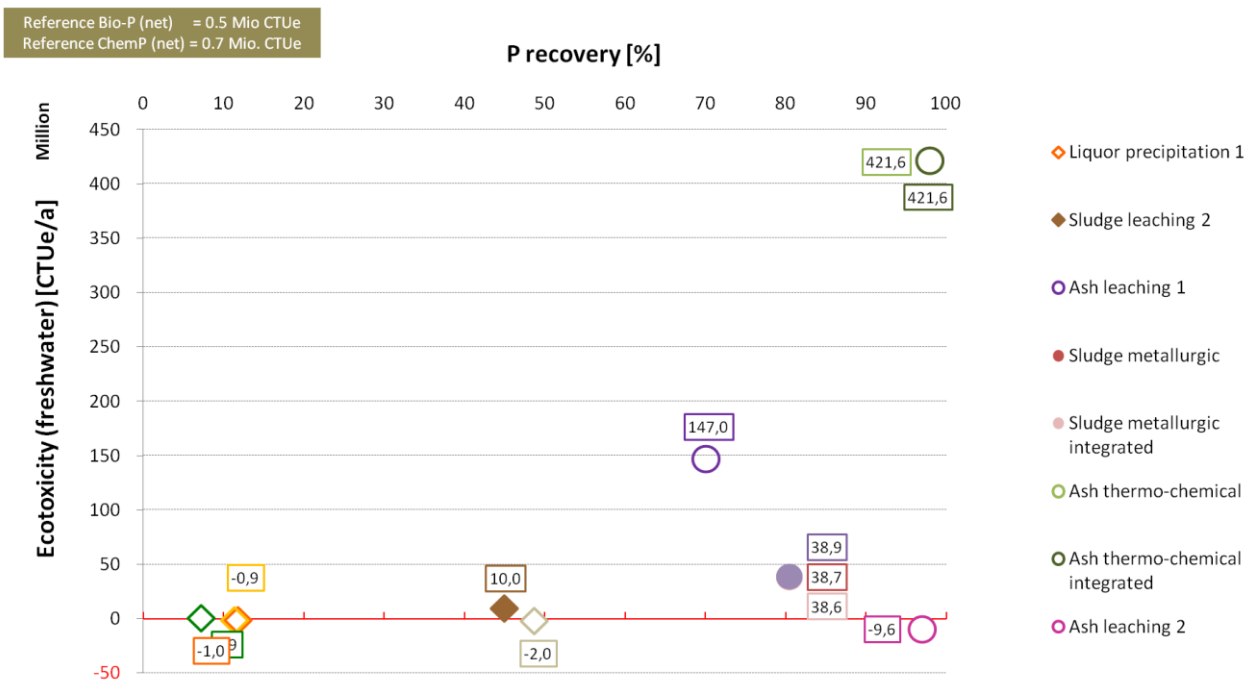

Figure 5-15: Total ecotoxicity (freshwater) related to P recovery potential

5.7 Human Toxicity

Human toxicity of P recovery from sludge and liquor is also dominated by the quality of secondary and mineral P fertilizer products (Figure 5-16). Again, struvite from sludge precipitation is assessed with higher human toxicity than mineral P fertilizer, leading to an overall increase (+1.6 CTUh/a). Struvite from liquor precipitation has a lower heavy metal content and reduces overall human toxicity by -0.5 CTUh/a. P product from sludge leaching of EBPR sludge is also lower in human toxicity than mineral P (-1.7 CTUh/a), while sludge leaching of ChemP sludge increases human toxicity by +2.6 CTUh/a.

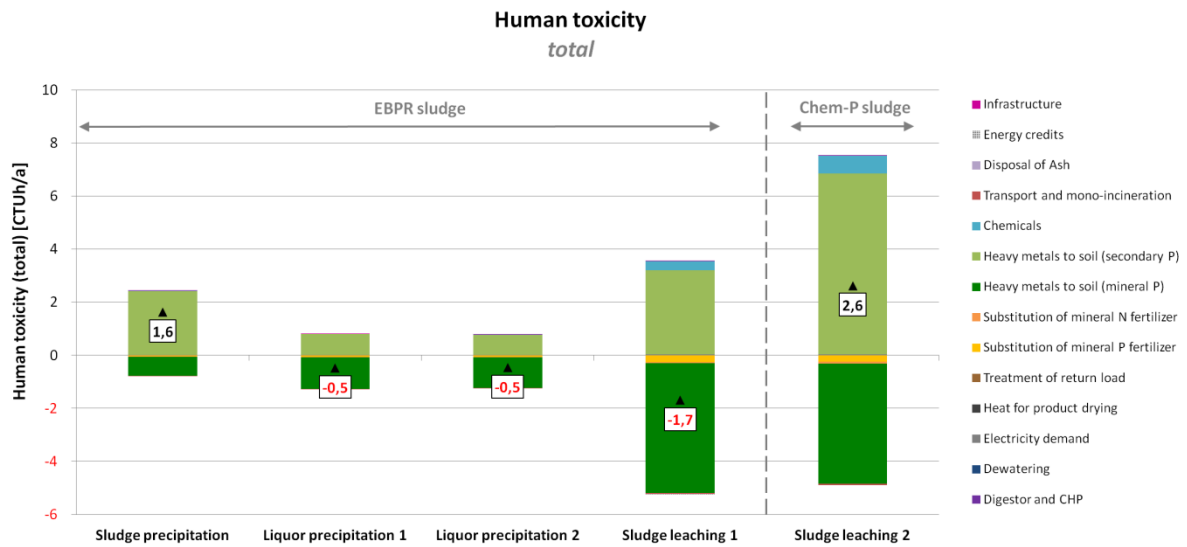

Figure 5-16: Total human toxicity of P recovery from sludge or liquor

For P recovery from dried sludge or ash, all P products are evaluated with higher human toxicity than the reference mineral P fertilizer, leading to a substantial increase in human toxicity (+51 to +549 CTUh/a). Again, the Ecophos product is an exception, with low heavy metal content and a resulting decrease in net human toxicity (-8 CTUh/a).

A closer analysis of human toxicity assessment reveals that the Zn content of the fertilizer products is the most important parameter in this category, accounting for >90% of human toxicity for most secondary P products. As Zn is known to be an essential trace nutrient also for humans, the high impact of Zn in human toxicity seems not reasonable in this LCA, but this relies on impact factors of the global USEtox® consensus model. An alternative indicator for human toxicity is calculated in sensitivity analysis (chapter 5.9.2) to check if this effect is reproduced with other impact assessment models.

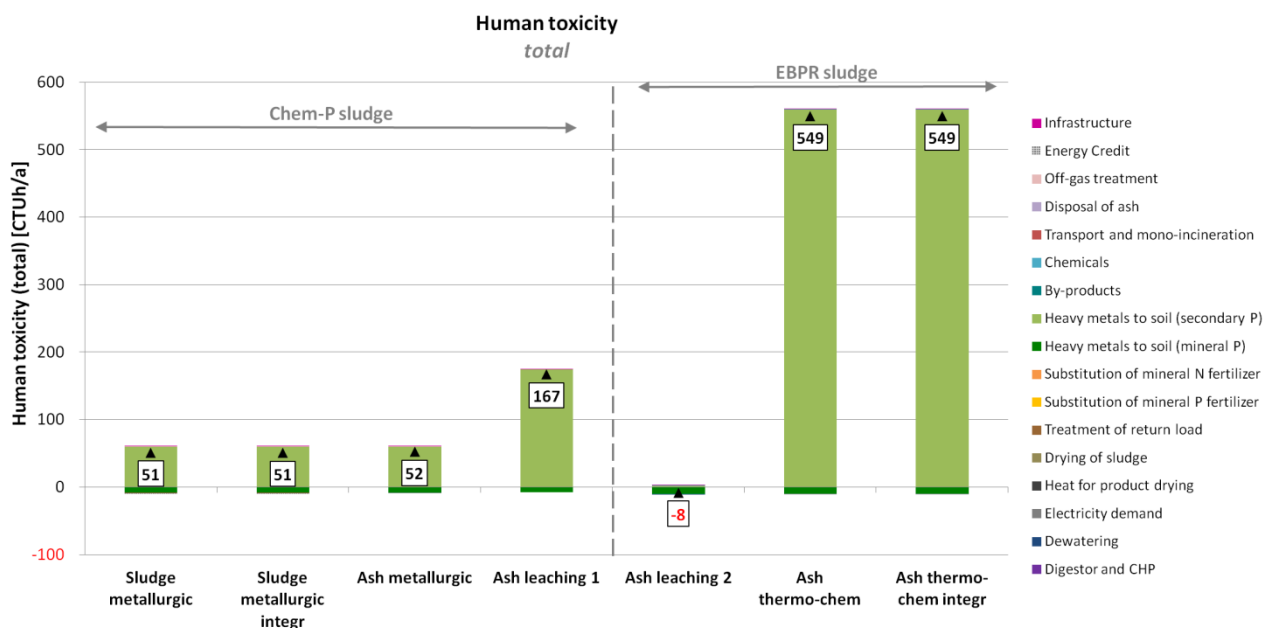

Figure 5-17: Total human toxicity of P recovery from dried sludge or ash

As expected, the overall comparison between P recovery scenarios confirms that products from sludge and liquor are generally associated with lower human toxicity in this study, whereas some ash products are characterized with high human toxicity due to their high Zn content (Figure 5-18). Existing human toxicity of sludge disposal in incineration is within the same range (0.9 CTUh/a) due to impacts of Hg emissions from mono-incineration. Again, ash products are available that enable a high P recovery with low human toxicity (e.g. Ecophos).

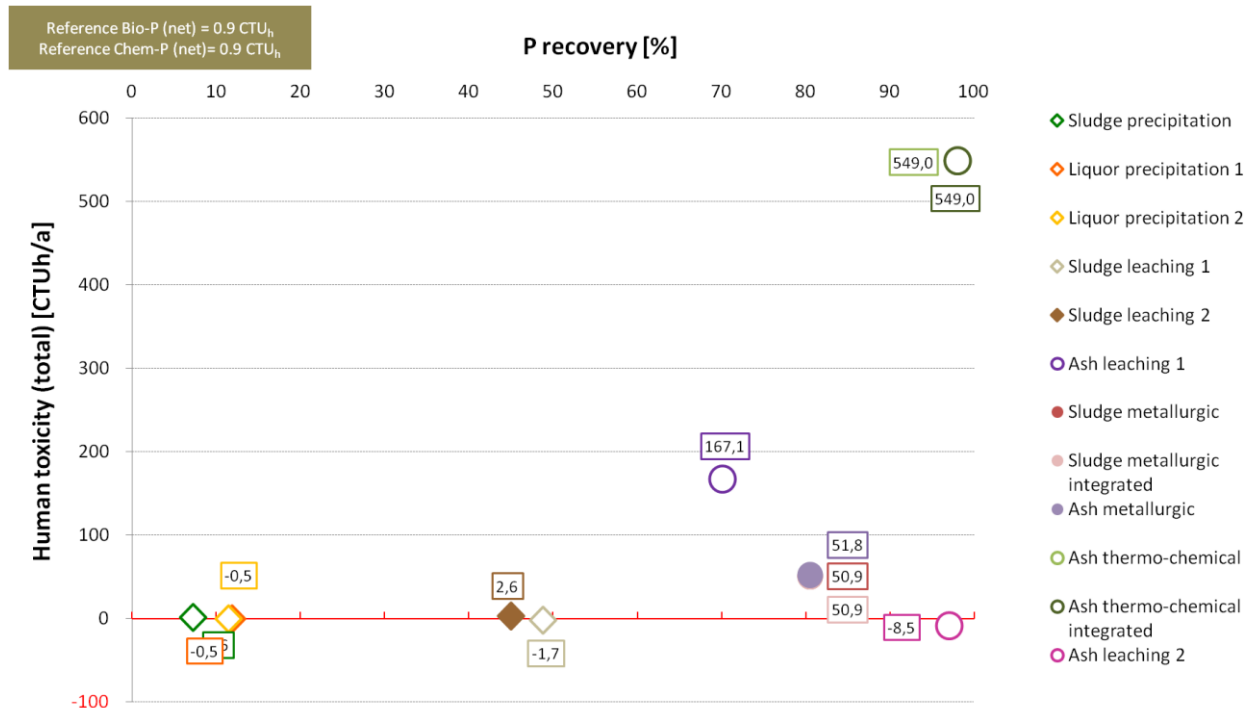

Figure 5-18: Total human toxicity related to P recovery potential

5.8 Normalisation

Normalisation of all indicator results towards the total environmental impacts per person in EU27 reveals that toxicity evaluation has to be treated with caution in this LCA. In normalized scores, categories of human and ecotoxicity range up to 650.000 pe*a (Figure 5-19), whereas other impact categories contribute between +500 and -4500 pe*a (Figure 5-20). This normalisation result is rather unusual and may be affected by very high toxicity scores for secondary P products in this study, based on their high content of Cu and Zn. Nevertheless, this data reflects current characterization of metals in the consensus model USEtox® and latest normalisation factors, pointing towards the need for further development and refinement of the underlying models and impact characterization.

Comparing normalised scores of indicators without toxicity, energy-related indicators such as fossil and nuclear energy demand and also global warming are in the lower range of contribution (+500 to -750 pe*a), indicating that P recovery will not contribute significantly to a change in overall energy demand and GHG emissions of EU27 population. Medium effects can be expected in the categories of acidification, metal depletion, and marine eutrophication (+650 to -1800 pe*a). Highest positive impacts of P recovery originate from a reduction in freshwater

eutrophication (-400 to -4700 pe*a), indicating the positive effect of P recovery on overall emissions of phosphorus into freshwaters.

In conclusion, normalisation underlines that all processes in the WWTP chain (e.g. also sludge treatment and disposal) directly improving effluent water quality and reducing emission loads in freshwater are useful contributions for reducing negative effects on surface waters of societal activity. In addition, sustainable P management by recovering secondary P products from wastewater sludge will also be beneficial for surface water quality in other parts of the world, as P emissions in mining and processing of P rock will also be reduced. Aspects of energy demand and greenhouse gas emissions may also be important in a wider perspective, but the potential for savings is not that high for sludge management compared to the overall footprint of society.

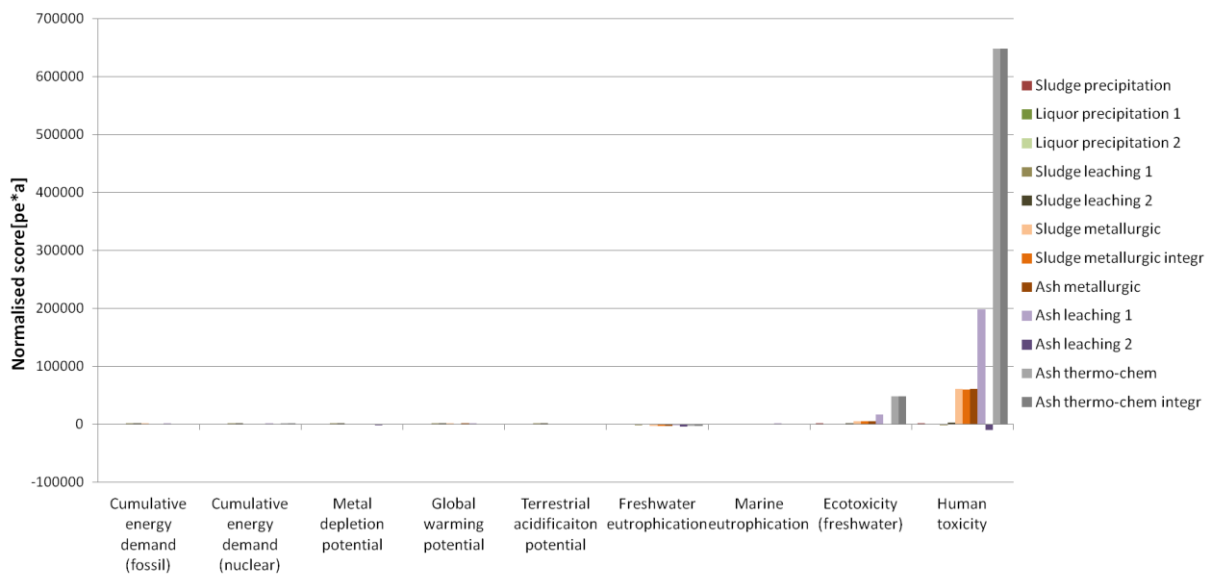

Figure 5-19: Normalised scores of all P recovery scenarios

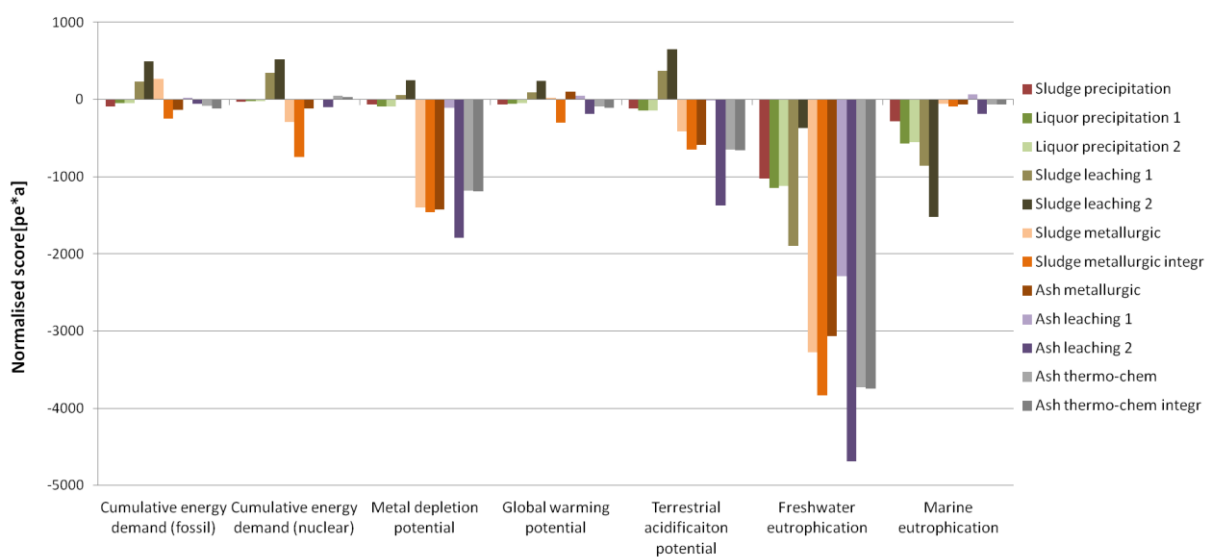

Figure 5-20: Normalised scores of all P recovery scenarios (human and ecotoxicity excluded)

5.9 Sensitivity analysis

In sensitivity analysis, the following aspects are checked in their influence on the LCA impact assessment:

- Alternative disposal routes for combining energy and P recovery
- Choosing alternative indicators for toxicity evaluation
- Variation in dissolved P content of the sludge
- Variation in impact of sludge precipitation (Airprex™) on sludge dewaterability

5.9.1 Alternative disposal routes for combining energy and P recovery

In this LCA study, the baseline scenario is defined as mono-incineration of digested and dewatered sludge. However, alternative routes for sludge disposal could also be applied to enable recovery of its nutrients and energy content. Potential alternatives include co-incineration in power plants (combined with upstream extraction of P from sludge), but also the traditional route of agricultural application. Both options are thus analysed in their environmental impacts here with a simplified assessment.

Co-incineration of sludge combined with P recovery

The baseline disposal route in this LCA study is mono-incineration, using BAT technology for energy recovery. However, the favorable energy balance of BAT mono-incineration (30% TS in the original facility) is lower when the data is transferred to the digested sludge of the P-REX model (Figure 5-21). This effect is mainly due to the higher water content of the P-REX sludge (25% TS), resulting in a lower effective heating value of the digested sludge (3.5 MJ/kg TS) than for the original sludge (5.8 MJ/kg TS). Using comparable efficiencies for electricity production (14% of H_u), energy demand (0.23 kWh/kg TS), and district heating output (73% of H_u), the P-REX model results in energy benefits of only 0.5 MJ/kg TS compared to 3.2 MJ/kg TS for the original BAT system. Hence, energy recovery from sludge is rather poor in the P-REX model, although BAT data from a new mono-incineration plant was used.

For improving the energy recovery from sludge, co-incineration in power plants is an option, because these large units provide good energy efficiency for converting the incoming fuel into electricity, and they often have excess heat available for pre-drying of sludge to improve its energy content. A drawback may be the required transport distance, because co-incineration facilities (power plants) are typically more distant to WWTPs than mono-incineration. Assuming a transport distance of 150km and an average net electrical efficiency of 33% for lignite power plants (without pre-drying of sludge, i.e. same H_u of dewatered sludge than in mono-incineration), the net energy balance of sludge incineration can be improved by 1.7 MJ/kg TS in this LCA (Figure 5-21), leading to a superior overall energy balance for sludge treatment and disposal.

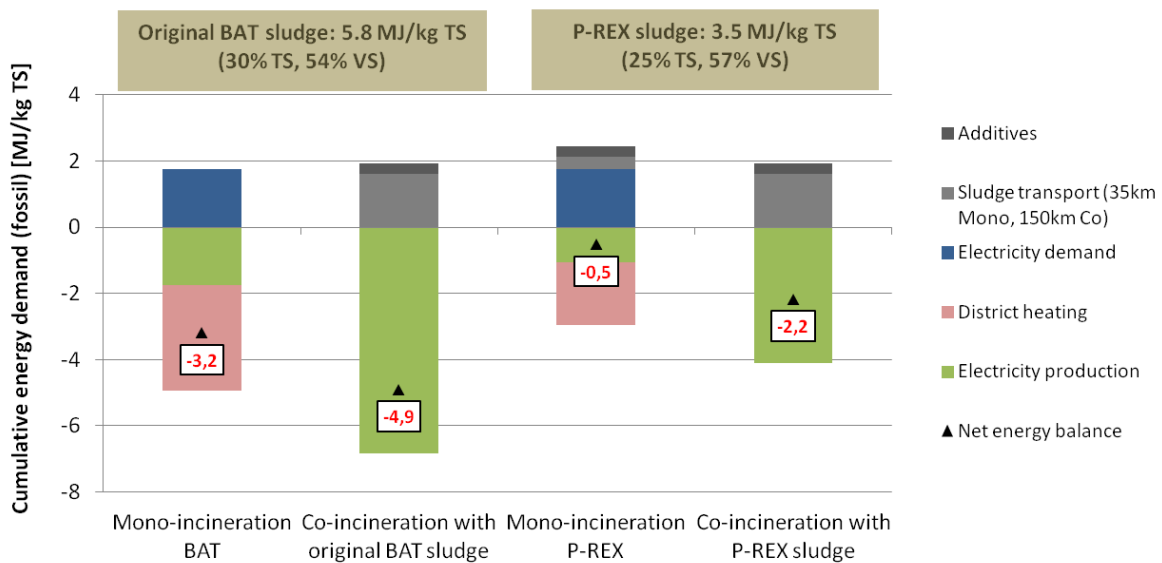

Figure 5-21: Fossil energy balance of mono-incineration and co-incineration for original sludge from BAT facility (left) and P-REX sludge (right)

However, sludge incineration in power plants will lead to a loss of its P content in the ashes, because these ashes are highly diluted with inorganic residues from coal burning and thus cannot be used effectively for P recovery. A possible combination of P recovery and improved energy recovery in co-incineration is only possible for those processes which recovery P in the sludge or liquor pathway. While direct sludge or liquor precipitation yield only smaller amounts of total P in sludge (7-12%), sludge leaching enables P recovery of 45-48% and may thus be combined with co-incineration of sludge after P extraction. This combination will enable the offset of high energy demand for sludge leaching (due to chemicals demand) with improved energy recovery during sludge incineration, finally leading to a scenario where both energy and P recovery will be targeted.

Agricultural application of sludge

The traditional disposal route of agricultural application enables the effective recycling of 100% of P content in the sludge, although plant availability of chemically bound P will be limited. In addition, a part of the nitrogen content in sludge will also replace mineral N fertilizer depending on application time, N turnover and plant availability. In this sensitivity analysis, it is estimated that 25% of total N and 100% of total P in sludge will replace the equivalent mineral fertilizer if EBPR sludge is applied in agriculture. Transport distance for dewatered sludge is assumed with 35km. Field emissions of sludge application and fuel demand for agricultural tractor are neglected here.

The implementation of co-incineration leads to an overall energy benefit of -19.5 Mio MJ/a for the reference scenario with EBPR sludge compared to mono-incineration baseline, thus improving the net energy credits by another 23% compared to the baseline. By combining P recovery with sludge leaching 1 (Gifhorn), net energy balance of P recovery can be substantially reduced from 24.1 Mio MJ/a to 4.6 Mio MJ/a for this pathway (Figure 5-22). This effect will be comparable for the other sludge leaching option (Stuttgart), saving also -19.5 Mio MJ/a by switching to co-incineration.

Agricultural application results in an even higher energy benefit, with -51.9 Mio MJ/a compared to baseline mono-incineration of EBPR sludge (+61% in total credits of sludge disposal). Although direct credits from energy recovery in sludge incineration are lost, substituted P and N fertilizer lead to a significant benefit of this disposal route (Figure 5-22). This underlines that nutrient content is more valuable in energetic terms than energy content of organic matter in dewatered sludge. In addition, some efforts for ash disposal can be avoided with agricultural disposal.

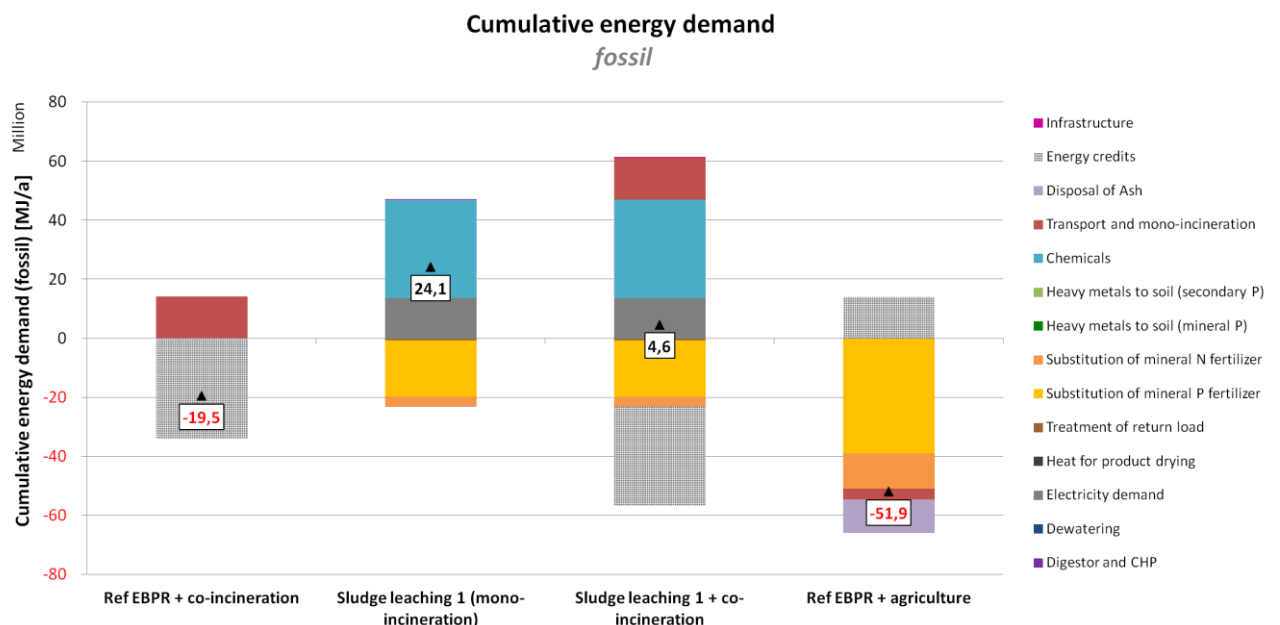

Figure 5-22: Total cumulative energy demand (fossil) of selected scenarios assuming co-incineration or application in agriculture

Another benefit of co-incineration is related to the mitigation of N_2O emissions, which are known to be high in fluidized-bed mono-incineration due to its specific freeboard temperature of 870-900°C (ATV 1996, Sanger et al. 2001) and the relatively high N content of sludge as input fuel. For co-incineration, temperatures of incineration are usually >1000°C, so that lower N_2O emission factors can be expected. Assuming an N_2O emission factor of 10% for co-incineration compared to mono-incineration (Svoboda et al. 2006), GWP of co-incineration is substantially lower than mono-incineration due to mitigation of N_2O emissions and improved energy balance. In this LCA, GWP savings amount to -6.2 Mio kg CO_2 -eq/a for the reference scenario with co-incineration compared to the mono-incineration baseline (Figure 5-23). For the P recovery with sludge leaching 1, this will totally off-set GWP of P recovery (1.0 Mio kg CO_2 -eq/a) and lead to

overall savings of -5.2 Mio kg CO₂-eq/a. These savings are very significant also compared to the overall GWP of sludge treatment and disposal, which are in the range of -1.4 Mio kg CO₂-eq/a for the reference with mono-incineration. Finally, the combination of P recovery from sludge leaching and co-incineration will further increase existing GWP credits of sludge disposal in mono-incineration by 370%.

Again, agricultural application has even higher benefits in GWP, reducing GHG emissions by another -8.7 Mio kg CO₂-eq/a compared to the baseline mono-incineration. Both fertilizer credits (P and N) and mitigated emissions of incineration (N₂O) contribute to GWP reduction for this disposal route (Figure 5-23).

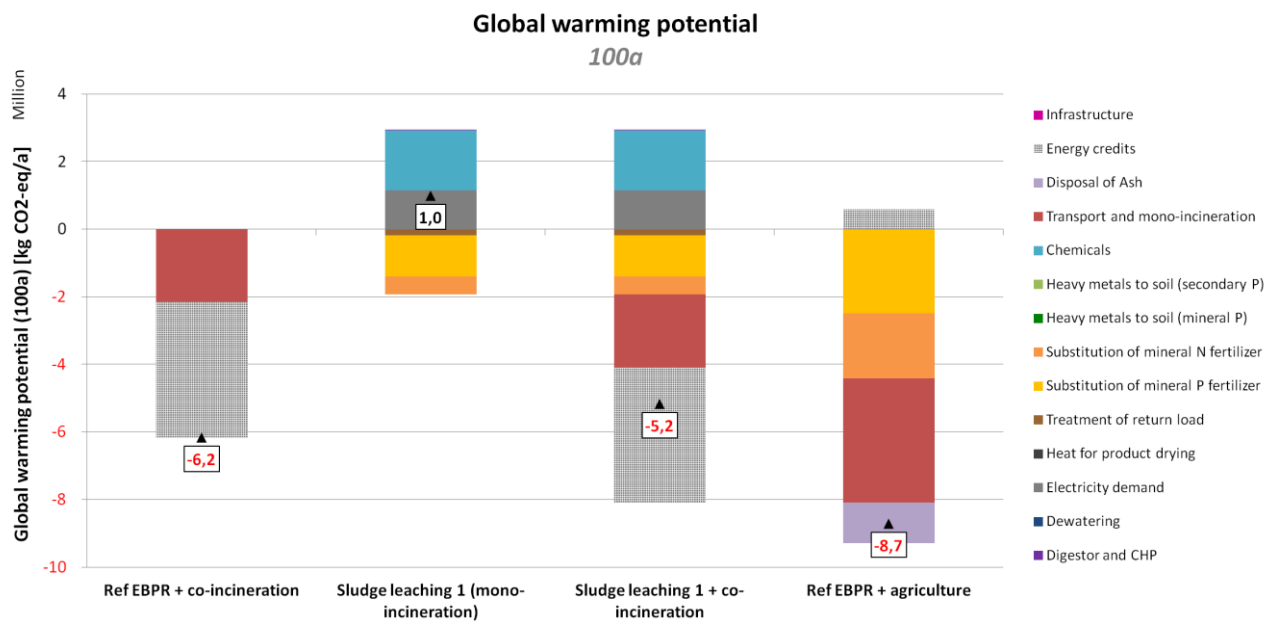

Figure 5-23: Total global warming potential (100a) of selected scenarios assuming co-incineration or application in agriculture

This sensitivity analysis of energy demand and GWP has shown that co-incineration combined with upstream P extraction may provide an option where a moderate recovery ratio for P (~50%) can be combined with better energy recovery and lower GHG emissions than mono-incineration. However, potentially negative environmental effects of co-incineration (e.g. increased emissions of heavy metals due to less effective flue gas cleaning) that have not been analysed in detail should be carefully investigated before this option can be recommended.

Direct application of sludge in agriculture proves to be the most effective way of valorizing nutrient content in sludge, yielding high credits for substituting both P and N content which results in high energy credits and GHG mitigation compared to incineration options. However, this disposal route will result in the transfer of all inorganic and organic pollutants of the sludge to agricultural soil, which is seen more and more critical by the public and authorities and which already led to a ban of this disposal route in some countries. In this LCA, high scores for freshwater ecotoxicity (Figure 5-24) and human toxicity (Figure 5-25) are calculated for direct sludge application in agriculture, thus reflecting an inherent problem of this valorization route.

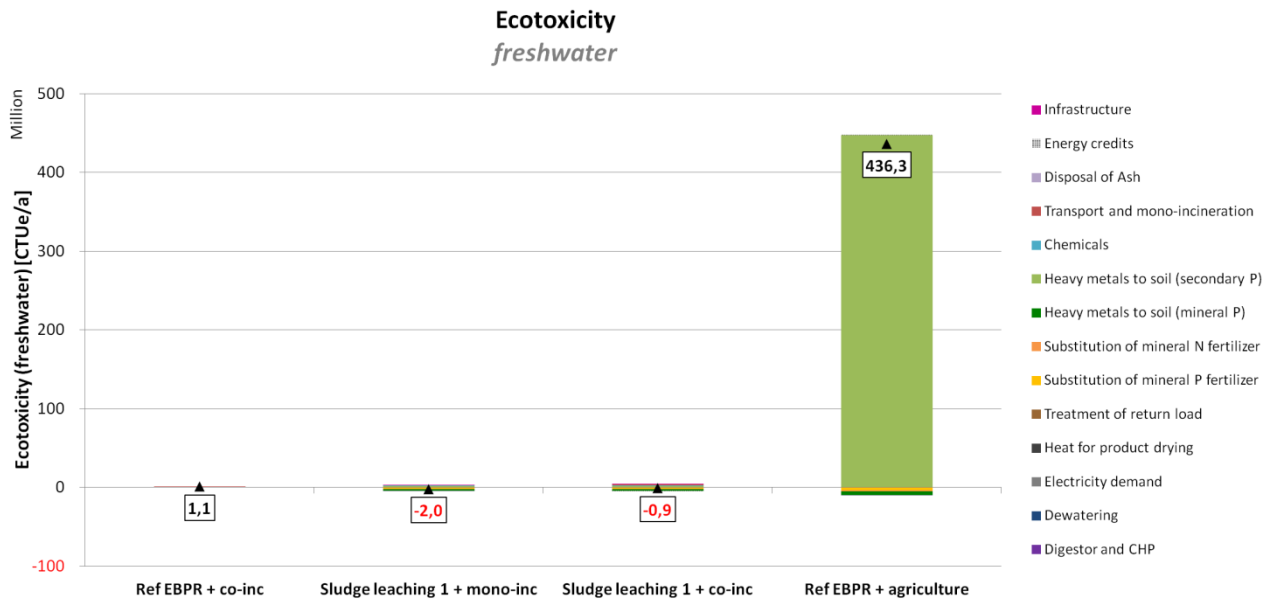

Figure 5-24: Total ecotoxicity (freshwater) of selected scenarios assuming co-incineration or application in agriculture

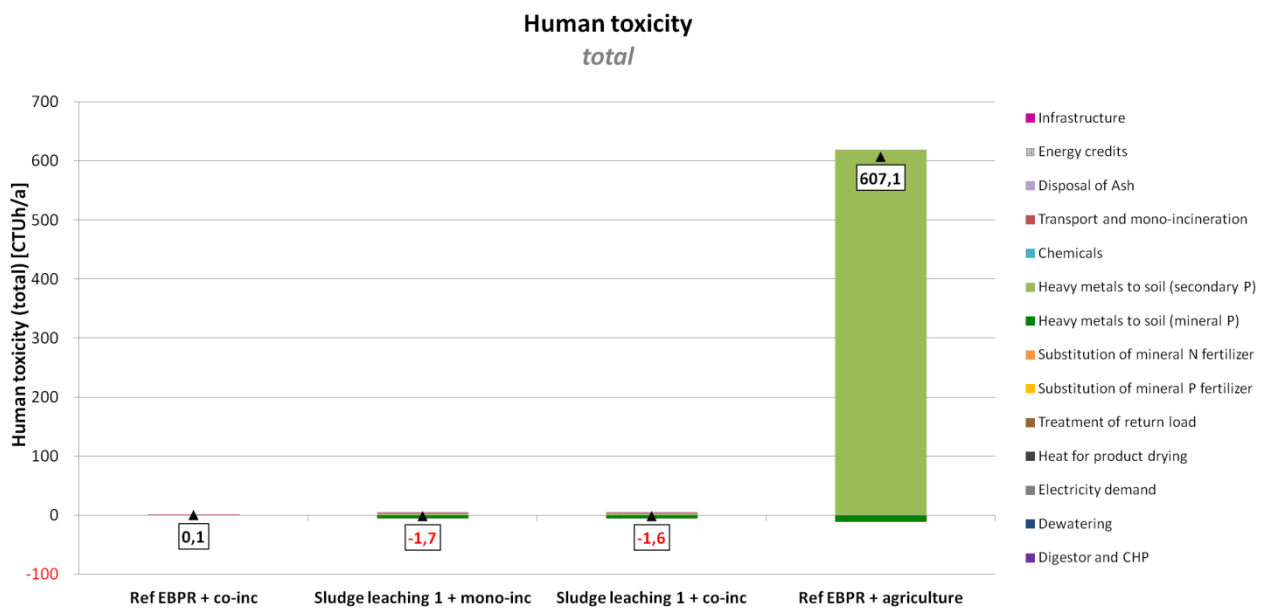

Figure 5-25: Total human toxicity of selected scenarios assuming co-incineration or application in agriculture

Finally, this analysis shows that current BAT mono-incineration does not constitute an optimum pathway for sludge disposal in the overall energy and GHG balance. Other alternatives such as co-incineration combined with upstream P recovery and agricultural application have their specific advantages, but also drawbacks which are only partially reflected in this simplified LCA. A final decision on suitable strategies for recovering nutrients and energy from sludge has to take into account these alternative routes for disposal to identify an optimum solution based on local boundary conditions and political targets.

5.9.2 Alternative indicators for human and ecotoxicity

Toxicity evaluation revealed that secondary P products are partially evaluated with very high toxicity scores, mainly due to their elevated content of Cu and Zn (cf. chapter 5.6 and 5.7). This effect is especially pronounced for products from treatment of dried sludge (metallurgic) or ash. However, this LCA applied the consensus model USEtox® for toxicity evaluation (Rosenbaum et al. 2008), which uses characterization factors for heavy metals still flagged as “interim” due to known uncertainties in metal fate and exposure (Ligthard et al. 2004). As an alternative, toxicity factors are also available based on the ReCiPe methodology accounting an infinite time horizon (Goedkoop et al. 2009) which are used here for sensitivity analysis.

Calculating freshwater aquatic ecotoxicity potential (FAETP) which is comparable to ecotoxicity (freshwater) from USEtox®, the results reveal that most scenarios for P recovery will lead to a reduction in FAETP (Figure 5-26 and Figure 5-27) except of sludge leaching 2 (high impact caused by production of citric acid and MgO). However, this effect is not caused by the better quality of secondary over mineral P products, but is due to mitigated emissions in background processes of mineral P fertilizer production. Overall, Cu and Zn loads to agricultural soils with secondary P products are not contributing heavily to FAETP indicator, also for products from dried sludge or ash (Figure 5-27). High credits for ash leaching 2 are caused here by substitution of CaCl₂ production.

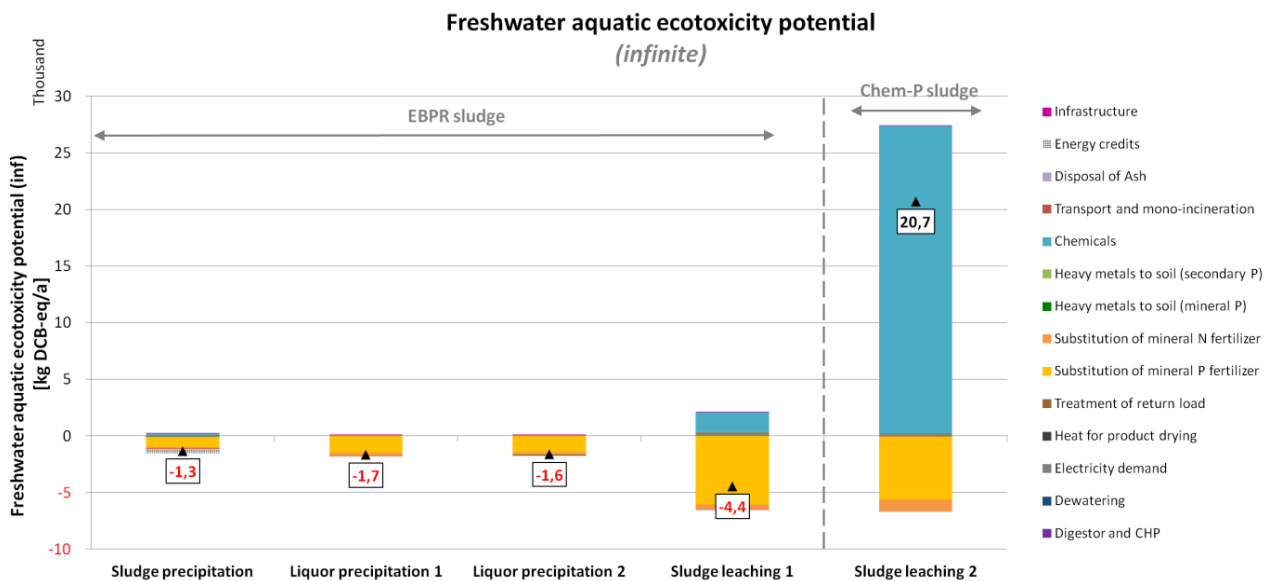

Figure 5-26: Freshwater aquatic ecotoxicity potential (inf) for P recovery from sludge or liquor

For human toxicity potential (HTP) accounting an infinite time horizon, most secondary P products are evaluated with lower toxicity scores than the mineral P fertilizer (Figure 5-28 and Figure 5-29). Only for products from sludge leaching 2 (Stuttgart), ash leaching 1 (Leachphos), and thermo-chemical ash treatment (AshDec), secondary P products are evaluated with higher toxicity than the mineral P product. Background emissions causing HTP are mainly related to air emissions from energy production of process-specific off-gas.

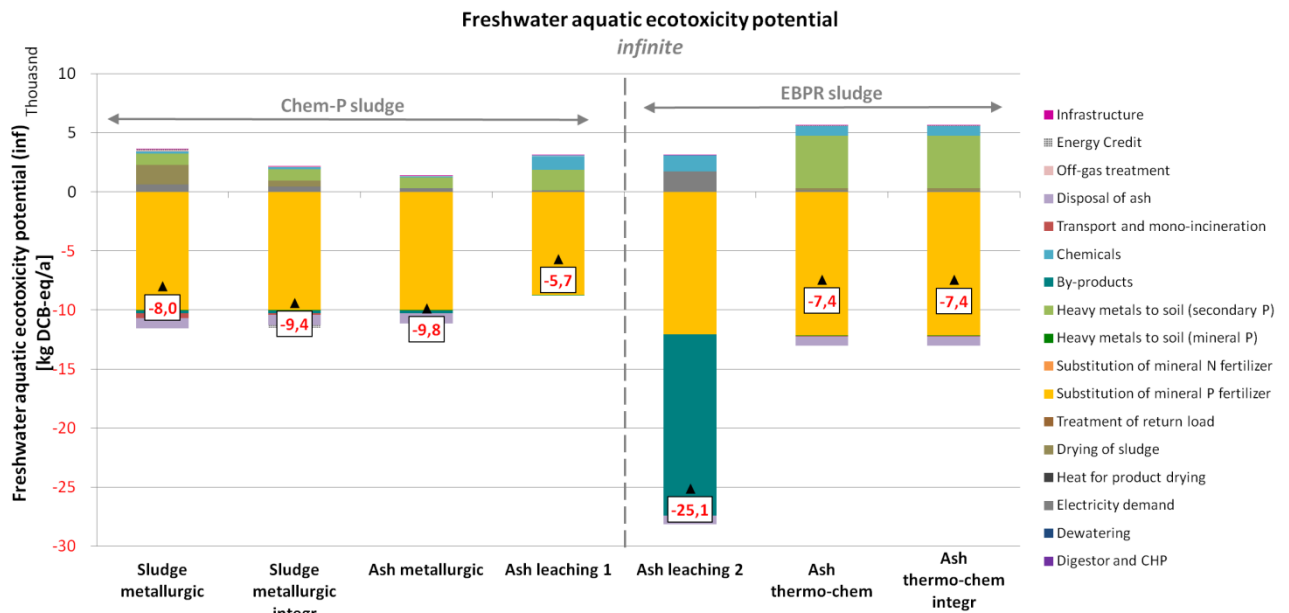

Figure 5-27: Freshwater aquatic ecotoxicity potential (inf) for P recovery from dried sludge or ash

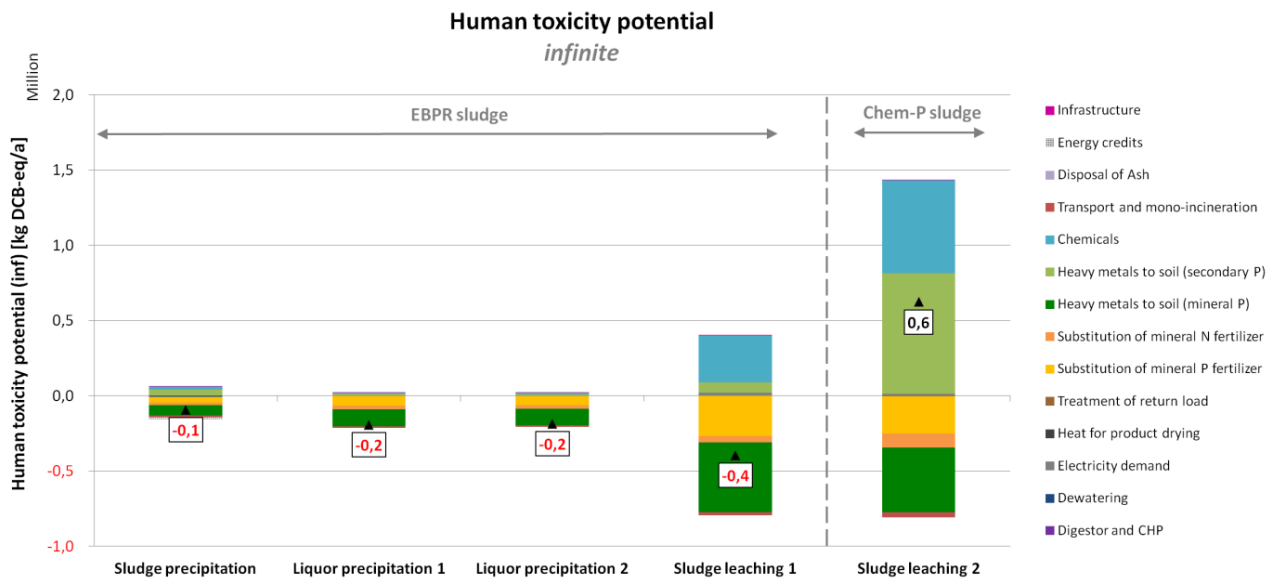

Figure 5-28: Human toxicity potential (inf) for P recovery from sludge or liquor

Overall, sensitivity analysis for choice of toxicity indicators further underlines the high uncertainty in evaluating secondary P products in their toxicity for humans and ecosystems with LCA indicators. Further tools based on actual risk assessment of contaminants in secondary and mineral P products have been applied in P-REX (D9.1) to enable a well-founded conclusion on the product quality of P recovery pathways from sludge, liquor, or ash. Existing LCA indicators are based on global models for fate and exposure and are not based on specific speciation of metal emissions, which may not adequately reflect the real-world conditions for application of secondary P products in agriculture.

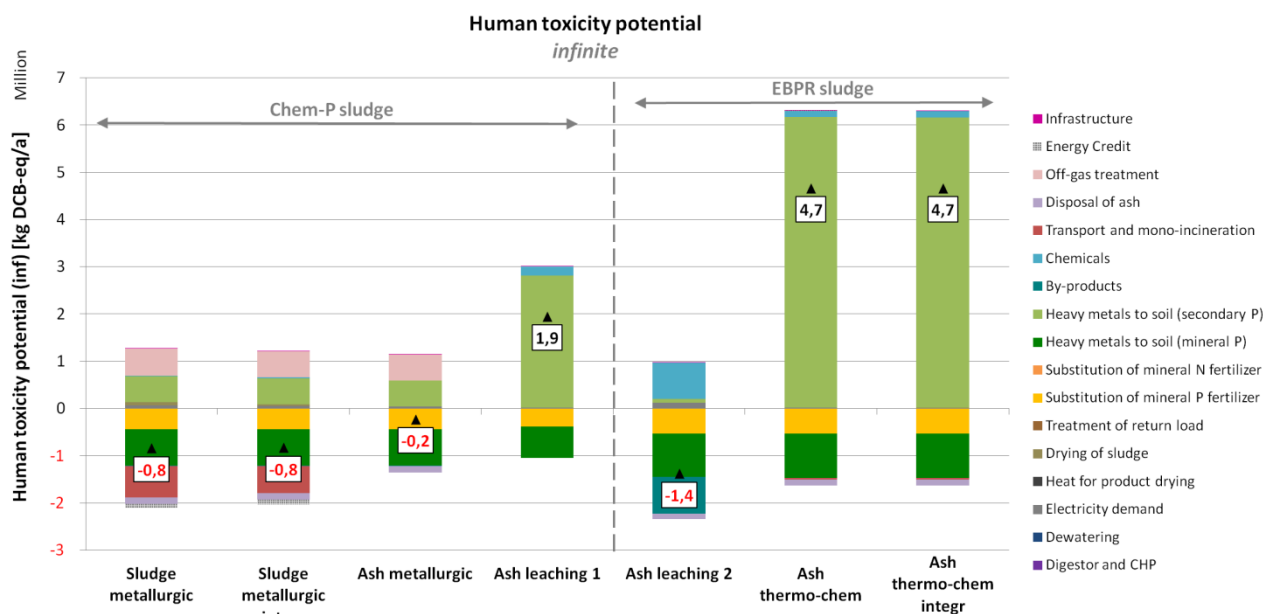

Figure 5-29: Human toxicity potential (inf) for P recovery from dried sludge or ash

5.9.3 P content of liquor

Pre-defined content of dissolved $\text{PO}_4\text{-P}$ in the P-REX reference model after digestion has a major influence on the ratio of P recovery that can be realized with processes working directly on this dissolved fraction (= direct sludge or liquor precipitation). However, dissolved $\text{PO}_4\text{-P}$ concentration can vary over a wide range in digested EBPR sludge, so that process efficiencies for these pathways can change dramatically. Varying the dissolved P concentration in the reference model (200 mg/L $\text{PO}_4\text{-P}$) between 100 and 300 mg/L $\text{PO}_4\text{-P}$ results in a variation of P recovery ratio of 4-11% for sludge precipitation (Airprex™) and 6-18% for liquor precipitation (Pearl® and Struvia™) (Figure 5-30). In consequence, any pre-treatment of digested sludge (e.g. thermal hydrolysis, WASSTRIP®) which increases dissolved P concentration after digestion will be highly beneficial for the efficiency of these processes that recover P directly via precipitation of the dissolved fraction.

For the fossil energy demand, credits per kg P recovered will increase with higher dissolved P content for P recovery from liquor, because more P fertilizer is substituted. This effect is entirely different for sludge precipitation: due to the high credits from improved sludge dewatering (which are assumed independent of dissolved P content for this calculation), relative energy credits per kg P decrease with increasing P recovery, because these credits are distributed to a higher amount of total P. However, dissolved P concentration may well influence dewatering results (% TS) in reference scenario and thus potential improvements by struvite precipitation, which cannot be reflected in this calculation due to lack of consistent data. More full-scale data should be collected on effective increase in dewaterability (% TS) due to implementation of sludge precipitation plants.

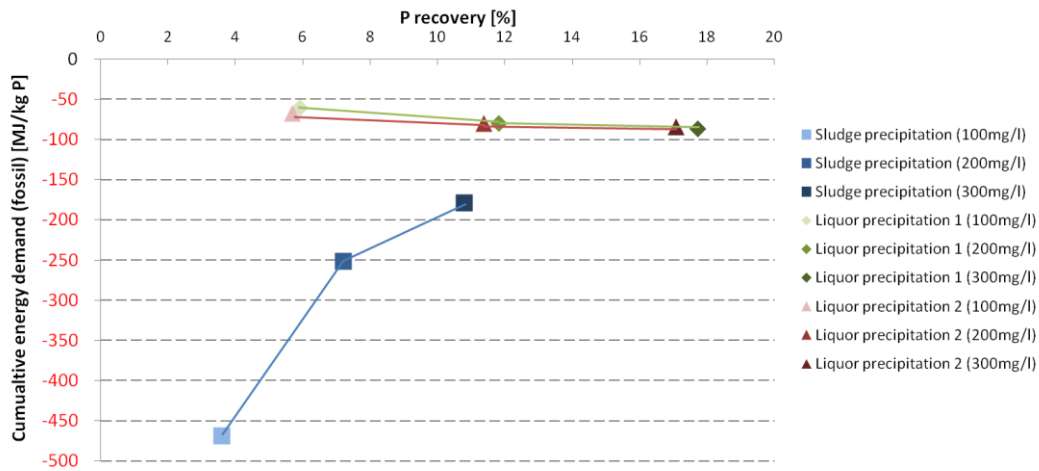

Figure 5-30: Cumulative energy demand (fossil) per kg P for sludge and liquor precipitation depending on dissolved PO₄-P concentration in sludge

5.9.4 Increase in dewatering by sludge precipitation

For evaluating the environmental profile of direct precipitation of P as struvite in digested sludge, side effects on sludge dewaterability are decisive for the positive evaluation in energy demand and related greenhouse gas emissions (cf. chapter 5.1 and 5.2). Increase in TS after dewatering is projected as +2% TS in this LCA study, but effective increase may range between 0% TS (= no effect on dewatering) up to +4% TS. If no increase in dewaterability is projected, credits in fossil energy demand for this scenario are completely neutralised, leading to a final energy credit of only -0.5 Mio MJ/a (Figure 5-31). In contrast, a high effect on dewaterability will significantly increase credits to -17.2 Mio MJ/a. This sensitivity shows that a valid assessment of effective energy and greenhouse gas balance of sludge precipitation (e.g. Airprex™) depends heavily on the side effects on dewatering, which should be monitored closely and reported for each full-scale plant. This process can be very beneficial for the overall energy balance (and also costs for sludge disposal) if dewatering can be measurably improved, but it may also be less superior in energy balance if no effect on dewaterability can be realized.

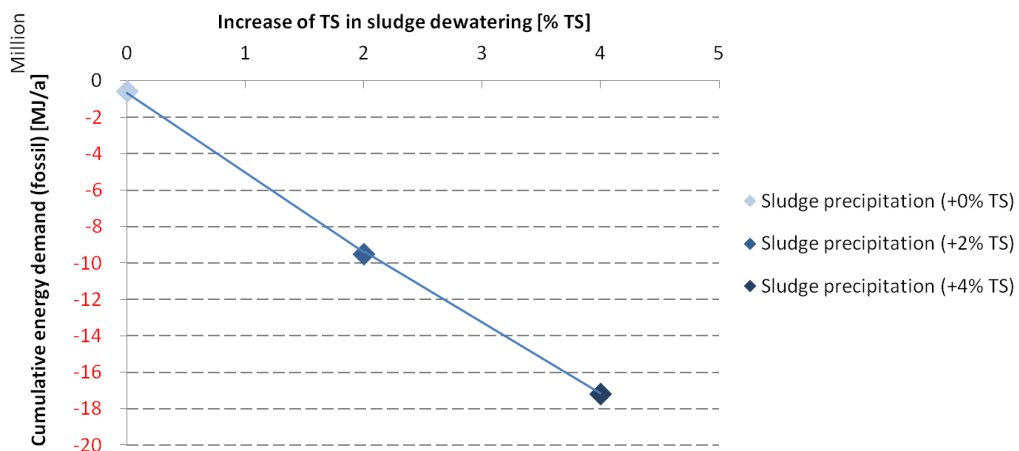

Figure 5-31: Cumulative energy demand (fossil) of sludge precipitation depending on TS increase in sludge dewatering

6 Interpretation and conclusions

6.1 Environmental profiles of P recovery processes and pathways

P recovery from municipal wastewater sludge, liquor, or ash of mono-incineration can be realized with environmental benefits in a life-cycle perspective. In general, different pathways and technologies are available, which can reduce major environmental impacts such as fossil energy demand, global warming potential, eutrophication of freshwaters due to P emissions, and human or ecotoxicity (Table 6-1). Efforts in energy and chemicals demand for P recovery can be off-set by substituting mineral P fertilizer production and other by-products and improve WWTP operation by reducing return load from sludge dewatering.

Table 6-1: Environmental impacts of P recovery from sludge, liquor, or ash in relation to a reference model of sludge treatment and disposal in mono-incineration for a 1 Mio pe WWTP

Pathways	Input sludge	P yield ¹	Fossil energy demand	Global warming	Eutro-plication freshwater	Eco-toxicity	Human toxicity
			[Mio MJ]	[kt CO ₂ -eq]	[t P-eq]	[Mio CTU _e]	[CTU _h]
	<i>Unit per a</i>						
Sludge precipitation	EBPR	7% ²	-9.5 ³	-0.7 ³	-0.4	0.9	1.6
Liquor precipitation 1	EBPR	12% ²	-5.0	-0.6	-0.5	-1.0	-0.5
Liquor precipitation 2	EBPR	11% ²	-4.8	-0.6	-0.5	-0.9	-0.5
Sludge leaching 1	EBPR ⁴	49%	24.1	1.0	-0.8	-2.0	-1.7
Sludge leaching 2	ChemP ⁴	45%	51.6	2.7	-0.2	10.0	2.6
Sludge metallurgic	ChemP ⁴	81%	27.9	0.3	-1.4	38.7	50.9
Sludge metallurgic (integrated in MSWI)	ChemP ⁴	81%	-26.0	-3.4	-1.6	38.6	50.9
Ash metallurgic	ChemP ⁴	81%	-14.5	1.1	-1.3	38.9	51.8
Ash leaching 1	ChemP ⁴	70%	2.7	0.5	-0.9	147.0	167.1
Ash leaching 2	EBPR ⁴	97%	-6.1	-2.1	-1.9	-9.6	-8.5
Ash thermo-chemical	EBPR ⁴	98%	-8.1	-1.0	-1.5	421.6	549.0
Ash thermo-chemical (integr. in mono-inc)	EBPR ⁴	98%	-12.6	-1.3	-1.6	421.6	549.0

¹ related to total P load in raw mixed sludge = 100%

² depending on dissolved PO₄-P concentration in digested sludge, reference is 200 mg/L PO₄-P

³ depending on effects on sludge dewaterability, reference is +2% TS

⁴ both EBPR and ChemP sludge or ash possible

Pathways for P recovery and respective technologies show distinct characteristics in the relative amount of P that can be recovered, but also in the demand of energy, chemicals and fuels or in side effects on return load. In detail, the following conclusions can be drawn from this LCA:

- **Sludge precipitation (Airprex™):** direct precipitation of struvite in digested EBPR sludge can recover 4-11% of P load in sludge depending on the dissolved $\text{PO}_4\text{-P}$ concentration (100-300 mg/L $\text{PO}_4\text{-P}$). Efforts in energy and chemical demand are higher than precipitation in liquor, but these are completely off-set by an increase in downstream dewaterability (+2% TS) which has been reported in full-scale EBPR plants. This increase in TS of dewatered sludge leads to higher energy credits in final incineration of sludge, so that the struvite product from sludge precipitation comes with significant credits in total energy demand and GHG emissions. Product quality in terms of heavy metal concentration is good, but is evaluated with slightly higher human and ecotoxicity than mineral P fertilizer using a global toxicity model.
- **Liquor precipitation (Pearl® and Struvia™):** struvite precipitation in dewatering liquor of EBPR plants can recover 6-14% of P load in sludge depending on dissolved $\text{PO}_4\text{-P}$ concentration in liquor (100-300 mg/L $\text{PO}_4\text{-P}$). Efforts in energy and chemical demand are low for both technologies, so that credits for substituted mineral fertilizer and reduced return load lead to an overall negative footprint of struvite from liquor. Product quality is excellent with low heavy metal content, so that human and ecotoxicity evaluation of struvite is lower than mineral P fertilizer.
- **Sludge leaching (Gifhorn and Stuttgart):** acidic leaching of EBPR or ChemP sludge and recovery of P products by precipitation from the leachate can recover 45-49% of total P load in sludge, but with a significant demand in acid and corresponding caustic for pH control. In addition, transfer of metals in P products has to be minimized by addition of masking agents (citric acid) or sulfides for metal precipitation (Na_2S). Overall, both technologies for P recovery lead to a substantial increase in energy demand and GHG emissions due to the high chemical demand, which cannot be off-set by credits for mineral P fertilizer. Compared to the existing credits of the sludge line from biogas valorisation and incineration, P recovery with sludge leaching reduces these energy credits by 29-70% and GHG emission credits by 71-800%, the latter corresponding to an overall increase of 2700 t $\text{CO}_2\text{-eq/a}$ for a 1 Mio pe WWTP. Product quality of sludge leaching is comparable or better than mineral P fertilizer in terms of human and ecotoxicity potential depending on the choice of toxicity model for LCA.
- **Sludge or ash metallurgic (Mephrec®):** metallurgic treatment of dried sludge or incineration ash can recover 81% of total P load in sludge and requires high input of fuels and energy for drying of sludge. For dried sludge as input, the overall energy

balance of the process heavily depends on the availability of heat for sludge drying and efficient valorisation of the generated high-calorific off-gas. Whereas a stand-alone plant for metallurgic sludge treatment will have a considerable total energy demand and carbon footprint (based on model predictions), its integration into an existing waste incineration facility with excess heat available for sludge drying and efficient gas valorisation can result in a P recovery process with substantial credits in energy and GHG emissions. Metallurgic ash treatment will have a significant carbon footprint, but decrease overall energy demand. Product quality of metallurgic sludge or ash treatment is acceptable, but high Cu and Zn content results in high potentials for human and ecotoxicity in the consensus toxicity model USEtox®.

- **Ash leaching (Leachphos and Ecophos):** environmental characteristics of leaching from ashes of mono-incineration depend on the type of technology applied. The Leachphos process can recover 70% of P from the ashes, but uses considerable amounts of chemicals for leaching and pH control, leading to an overall increase in energy demand and GHG emissions in this LCA despite high P fertilizer credits. Product quality is evaluated with high potentials for human and ecotoxicity due to elevated content of Cu, Zn and Cd. In contrast, the Ecophos process yields a very pure P product (H_3PO_4) with low toxicity potentials via digestion of ashes in diluted H_3PO_4 and subsequent multi-stage purification of the leachate in ion exchangers (IEX). Energy demand for steam concentration of product and chemical demand for IEX regeneration are relatively high, but are completely off-set by credits for substituted mineral P fertilizer and other valuable by-products ($CaCl_2$, $FeCl_3$) of the purification process. The Ecophos process can recover up to 97% of total P load in ashes with credits in all environmental indicators.
- **Ash thermo-chemical (Ash Dec):** thermo-chemical treatment of ashes in a rotary kiln can recover up to 98% of the total P load by turning the ashes into a P product. Addition of Na additives and dried sludge as reducing agent leads to depletion of selected heavy metals in the ash. Energy demand for heating ashes and kiln and chemicals production is completely off-set by fertilizer credits, leading to an overall negative energy and carbon footprint of the AshDec product. Integration of the process into an existing mono-incineration plant can further reduce energy demand and GHG emissions. Product quality is evaluated with high potentials in human and ecotoxicity in the global toxicity models of LCA due to very high content of Cu and Zn in the product.

In general, it can be concluded from this LCA study that P recovery can be realized in different pathways and processes with environmental benefits. However, pathways and technologies differ heavily in their total amount of recovered P (from 6-98%) and environmental profile in this LCA, so that a detailed analysis is recommended on a case-by-case basis to choose the most

suitable pathway and process for P recovery depending on the specific boundary conditions. Important aspects in this perspective are the type of sludge (EBPR or ChemP), the dissolved $\text{PO}_4\text{-P}$ content in the liquor, and potential options for process integration in near-by incineration facilities.

Processes working on mono-incineration ashes will depend on this option for sludge incineration, which may not pose an optimal solution with regard to energy recovery from sludge. Alternative disposal routes such as co-incineration of sludge in power plants may be combined with upstream P extraction, thus increasing the overall energy recovery significantly and mitigating inherent GHG emissions from fluidized-bed mono-incineration at the cost of P that cannot be recovered from the diluted co-incineration ash (up to 50% of total P). Likewise, the traditional disposal route of direct application of sewage sludge in agriculture also enables high nutrient recovery (P and N) with high energy credits for substituting mineral fertilizer production, but is also associated with high emissions of inorganic and organic pollutants to agricultural soil. However, both disposal routes should be taken into account in decision making to identify suitable regional and national solutions depending on local boundary conditions and political targets, reflecting on the the potential trade-off between optimum energy balance and targeted P recovery. Normalisation of LCA results underline that energetic aspects of sludge management do not contribute much to the overall energy demand and GHG emissions of society, but these issues nevertheless play an important role in current and future political strategies and should not be overlooked.

6.2 Limitations of this study

Naturally, each LCA study is affected by certain limitations due to definition choices, data availability, and inherent short-comings of the LCA approach. LCA takes a global perspective on resource use and emissions, which does not include site-specific or temporal emission profiles, and aggregates effects over time and space. Hence, impact assessment reports on “potential” impacts only, without giving information about the actual effect that might occur due to a specific emission in a specific place and time.

Apart from these more general limitations of the method, specific limitations have to be taken into account when interpreting the results and conclusions of this LCA study:

- **Asymmetric quality of input data (model, pilot, full-scale):** although the initial goal of P-REX was to represent each process based on full-scale data, some processes (especially ash-based technologies) have not yet been realized in full-scale and rely on pilot or even modelled input data. This data has yet to be validated in full-scale plants to enable a final analysis of environmental impacts of these processes.
- **Plant-availability of P products not accounted:** outputs of the different P recovery pathways and processes are analysed based on the total P amount, not taking into account actual plant availability of the products. Whereas some products are directly plant-available (e.g. struvite, H_3PO_4 as raw material for P fertilizer), others may require

further processing of products to reach complete plant-availability of the phosphorus and thus effectively realize full credits for substituting mineral P fertilizer.

- **Transfer factors for heavy metals from input into product:** for most processes, heavy metal transfer factors from input material into product could not be derived from existing data. Hence, existing data of product quality from site-specific analysis was adopted for product evaluation, which does not directly correspond to metal content in reference sludge or ash.
- **Exclusion of specific metals and organic pollutants in P products:** for evaluation of product quality, this study considers 7 heavy metals (Cd, Cr, Cu, Hg, Ni, Pb, Zn), but does not take into account other metals (e.g. U, which is known for its high toxicity and which can be found in mineral P fertilizer) or organic pollutants. This choice was made to a lack of data, but also due to missing characterisation factors in LCIA models.
- **Uncertainty in toxicity modelling in global LCA models:** in general, existing uncertainty in toxicity modelling of LCA is estimated to be high due to difficult modelling of fate and exposure, especially for heavy metals where speciation of metals plays an important role for environmental fate (Ligthard et al. 2004). Thus, conclusions from global toxicity assessment of P products have to be interpreted with care, as choice of indicator models may influence the outcomes (cf. chapter 5.9.2). However, the consensus model USEtox® has been applied here, which represents state-of-the-art impact assessment of toxicity in LCA.
- **Outdated datasets for mineral fertilizer production:** datasets for mineral P fertilizer production originate from the 1990s (Patyk and Reinhardt 1997) and may not reflect the latest technology in P rock mining and processing, assuming that measures for environmental protection have been intensified over the last decades. However, updated datasets are not publically available at the time of writing this report, so that environmental credits from P fertilizer substitution may be overestimated here.
- **Non-representative datasets for chemicals (e.g. waste products):** in general, datasets for production of chemicals for P recovery processes take a specific production route into account, which may not always represent the type of chemical effectively used in the process. Some processes may use chemicals (e.g. acids) which are waste products of other industrial activities with sufficient quality, which can substantially reduce environmental footprint of these chemicals and hence impact the outcomes of this LCA. However, it was not feasible within the timeframe of this study to work on the details of chemical production for each process depending on the origin of the input chemicals.

6.3 Outlook

Upcoming regulations in national or EU legislation may foster the uptake of P recovery and recycling from municipal sewage sludge and incineration ash in the near future. Based on the results of this LCA, pathways and processes are available to realize the goal of closing the P cycle in society and simultaneously reduce the overall environmental impact of sludge management and fertilizer production. However, a site-specific assessment of local and regional conditions is necessary to identify optimum solutions for P recovery based on political targets and existing infrastructure. Whereas this LCA can help in a first orientation towards environmentally friendly technologies and pathways, further analysis is recommended using the LCA method to develop suitable local, regional and national strategies for P recovery and overcome some inherent limitations of this LCA. In particular, large-scale demonstration plants for all technologies should be analysed in detail with scientific backing to collect representative full-scale data of all pathways and enable a comprehensive assessment of their environmental impacts and benefits based on validated input data. This will help in building more confidence in outcomes of the environmental assessment of P recovery and promote optimum solutions for protecting our environment.

7 References

- Adam, C. (2009): *SUSAN - Sustainable and Safe Re-use of Municipal Sewage Sludge for Nutrient Recovery - Final Activity Report*. Bundesanstalt für Materialforschung und –prüfung, Berlin, Germany.
- Antakyali, D., Meyer, C., Preyl, V., Maier, W. and Steinmetz, H. (2013): Large-scale application of nutrient recovery from digested sludge as struvite. *Water Practice and Technology* **8** (2), 256-262.
- ATV (2000): *A131 Bemessung von einstufigen Belebungsanlagen (A131: Dimensioning of single stage activated sludge plants)*. Abwassertechnische Vereinigung e.V., Hennef, Germany
- ATV (1996): Arbeitsbericht: NO_x und N₂O-Emissionen bei der Verbrennung von Klärschlamm (NO_x and N₂O emissions during incineration of sewage sludge). *Korrespondenz Abwasser, Abfall* **43** (7), 1299-1302.
- Bardtke, D., Müller, W. R. and Schäfer, C. (1994): *Untersuchungen zur Optimierung der Denitrifikation hinsichtlich der Entwicklung von elementarem Stickstoff und Distickstoffoxid (Lachgas) (Investigations to optimize denitrification concerning the formation of elementary nitrogen and dinitrogenmonoxide)*. Umweltbundesamt, Berlin, Germany
- Corominas, L., Foley, J., Guest, J. S., Hospido, A., Larsen, H. F., Morera, S. and Shaw, A. (2013): Life cycle assessment applied to wastewater treatment: state of the art. *Water Research* **47** (15), 5480-92.
- EC (2014): *Report on critical raw materials for the EU*. Report of the Ad hoc Working Group on defining critical raw materials , DG Growth, Brussels, Belgium.
- Ecoinvent (2014): *Ecoinvent data v3.1, ecoinvent reports No. 1-26, Swiss Center for Life Cycle Inventories, www.ecoinvent.org*. Dübendorf, Switzerland.
- Egle, L., Rechberger, H. and Zessner, M. (2014): *Phosphorrückgewinnung aus dem Abwasser (Phosphorus recovery from wastewater)*. Bundesministerium für Land- und Forstwirtschaft, Umwelt und Wasserwirtschaft, Sektion VII Wasser, Vienna, Austria.
- Eurostat (2015): *Gross inland energy consumption by fuel type* Eurostat, <http://ec.europa.eu/eurostat>, accessed on 07.08.2015,
- Fehrenbach, H. and Reinhardt, J. (2011): *Ökobilanzielle Bewertung der in der Förderinitiative entwickelten Verfahren (LCA of investigated processes)*. in: Phosphorrecycling - Ökologische und wirtschaftliche Bewertung verschiedener Verfahren und Entwicklung eines strategischen Verwertungskonzepts für Deutschland (PhoBe) (Recycling of Phosphorus - Ecological and Economic Evaluation of Different Processes and Development of a Strategical Recycling Concept for Germany (PhoBe)), Aachen, Germany
- Goedkoop, M. J., Heijungs, R., Huijbregts, M. A. J., De Schryver, A., Struijs, J. and Van Zelm, R. (2009): *ReCiPe 2008, A life cycle impact assessment method which comprises harmonised category indicators at the midpoint and the endpoint level; First edition Report I: Characterization*. <http://www.lcia-recipe.net>,
- Hagspiel, B. (2015): Klärschlammverwertung für die Region Nürnberg: Klärschlamm zu Energie und Dünger (Utilisation of Sewage Sludge for the Nürnberg Region: Sewage Sludge for Energy and Fertiliser). *Korrespondenz Abwasser, Abfall* **62** (5), 448-458.
- Hauschild, M. Z., Goedkoop, M., Guinée, J., Heijungs, R., Huijbregts, M., Jolliet, O., Margni, M., De Schryver, A., Humbert, S., Laurent, A., Sala, S. and Pant, R. (2013): Identifying best existing practice for characterization modeling in life cycle impact assessment. *International Journal of Life Cycle Assessment* **18** (3), 683-697.
- Heinzmann, B. (2005): Phosphorus recycling in sewage treatment plants with biological phosphorus removal. *Water Science and Technology* **52** 543-548.
- Heinzmann, B. and Lengemann, A. (2013): Vom Betriebsproblem zum Berliner Verfahren - Phosphorrückgewinnung als Magnesiumammoniumphosphat in der Kläranlage Wassmannsdorf (From operating problem to Berliner Process - Phosphorus recovery as

- Magnesium-Ammonium-Phosphate in the wastewater treatment plant Wassmannsdorf). DWA. 8. Klärschlammstage, Fulda, Germany.
- Hermanussen, O., Müller-Schaper, J., Haun, E., Weichgrebe, D., Rosenwinkel, K. H., Esemien, T., Dockhorn, T. and Dichtl, N. (2012): *Wissenschaftliche Begleitung der großtechnischen Anwendung der Seaborne-Technologie auf der Kläranlage Gifhorn: Abschlussbericht - Zusammenfassung der durchgeführten Untersuchungen und technisch-wirtschaftliche Bewertung der Verfahrenstechnik - (Scientific backing of full-scale implementation of Seaborne technology at the wastewater treatment plant Gifhorn: Final report - Summary of investigations and technical-economic assessment of the process)*. PFI Planungsgemeinschaft, ISAH Hannover, ISWW Braunschweig, Hannover/Braunschweig, Germany.
- IFU and IFEU (2014): *Umberto - Software für das betriebliche Stoffstrommanagement, Version Umberto NXT LCA (Umberto - software for operational substance flow management, version Umberto NXT LCA)*. Institut für Umweltinformatik GmbH und Institut für Energie- und Umweltforschung Heidelberg GmbH, Heidelberg/Hamburg, Germany.
- IPCC (2007): *Climate Change 2007: Synthesis Report. Contribution of Working Groups I, II and III to the Fourth Assessment Report of the Intergovernmental Panel on Climate Change* IPCC, Geneva, Switzerland
- IPCC (2006): *Guidelines for National Greenhouse Gas Inventories -Volume 5: Waste, Chapter 5: Incineration and open burning of waste*. IGES, Japan.
- ISO 14040 (2006): *Environmental management - Life Cycle Assessment - Principles and framework*. International Standardisation Organisation, Geneva, Switzerland
- ISO 14044 (2006): *Environmental management - Life cycle assessment - Requirements and guidelines*. International Standardisation Organisation, Geneva, Switzerland
- Klöpffer, W. and Grahl, B. (2009): *Ökobilanz (LCA): Ein Leitfaden für Ausbildung und Beruf (Life Cycle Assessment: A guide for education and practice)*. Wiley-VCH, Weinheim, Germany
- Krüger, O. and Adam, C. (2014): *Monitoring von Klärschlammmonoverbrennungsrückständen hinsichtlich ihrer Zusammensetzung zur Ermittlung ihrer Rohstoffrückgewinnungspotentiale und zur Erstellung von Referenzmaterial für die Überwachungsanalytik (Monitoring of sewage sludge ashes from mono-incineration regarding their elementary content to determine potentials for resource recovery and to define reference material for regular monitoring)*. UBA Texte 49/2014, Dessau, Germany.
- Laurent, A., Lautier, A., Rosenbaum, R. K., Olsen, S. I. and Hauschild, M. Z. (2011): Normalization references for Europe and North America for application with USEtox™ characterization factors. *International Journal of Life Cycle Assessment* **16** (8), 728-738.
- Ligthard, T., Aboussouan, L., Adams, W., Atherton, J., Baukloh, A., Chapman, P., Delbeke, K., Dubreuil, A., Eikelboom, R., Hauschild, M., Heijungs, R., Jolliet, O., Karman, C., Koning, A. d., Korenromp, R., Kuyper, J., Loos, R. v. d., Meent, D. v. d., Russell, A., Jan Saft, R., Sap, G., Schönnenbeck, M., Struijs, J., Tilborg, W. v., Udo de Haes, H. A. and Verdonck, F. (2004): *Declaration of Apeldoorn on LCIA of Non-Ferro Metals*. Apeldoorn, Netherlands.
- Linderholm, K., Tillman, A. M. and Mattsson, J. E. (2012): Life cycle assessment of phosphorus alternatives for Swedish agriculture. *Resources, Conservation and Recycling* **66** 27-39.
- MUNLV (1999): *Handbuch Energie in Kläranlagen (Handbook of energy in wastewater treatment plants)*. Ministerium für Umwelt, Raumordnung und Landwirtschaft des Landes Nordrhein-Westfalen, Düsseldorf
- Patyk, A. and Reinhardt, G. A. (1997): *Düngemittel - Energie- und Stoffstrombilanzen (Fertilizers: energy and substance flow balances)*. Vieweg, Braunschweig/Wiesbaden, Germany
- Petzet, S. and Cornel, P. (2011): Towards a complete recycling of phosphorus in wastewater treatment - options in Germany. *Water Science and Technology* **64** (1), 29-35.
- ReCiPe (2015): *Normalisation factors for Europe, from excel-file ReCiPe111.xls*. www.lcia-recipe.net (accessed on 07.08.2015).

- Remy, C. (2010): *Life Cycle Assessment of conventional and source-separation systems for urban wastewater management*. Dissertation, Department of Water Quality Control (<http://opus.kobv.de/tuberlin/volltexte/2010/2543/>), Technical University, Berlin.
- Römer, W. (2013): Phosphor-Düngewirkung von P-Recyclingprodukten (Phosphor Fertilization Effects of Phosphorus Recycling Products). *Korrespondenz Abwasser, Abfall* **60** (3), 202-215.
- Römer, W. (2006): Vergleichende Untersuchungen zur Pflanzenverfügbarkeit von Phosphat aus verschiedenen P-Recycling-Produkten im Keimpflanzenversuch (Plant availability of P from recycling products and phosphate fertilizers in a growth-chamber trial with rye seedlings). *Journal of Plant Nutrition and Soil Science* **169** (6), 826-832.
- Ronchetti, C., Bienz, P. and Pridal, R. (2002): *Ökobilanz Klärgasverstromung (Life cycle assessment of sewage gas electrification)* Bundesamt für Energie, Bern, Switzerland
- Rosenbaum, R. K., Bachmann, T. M., Gold, L. S., Huijbregts, M. A. J., Jolliet, O., Juraske, R., Koehler, A., Larsen, H. F., MacLeod, M., Margni, M., McKone, T. E., Payet, J., Schuhmacher, M., van de Meent, D. and Hauschild, M. Z. (2008): USEtox-the UNEP-SETAC toxicity model: recommended characterisation factors for human toxicity and freshwater ecotoxicity in life cycle impact assessment. *International Journal of Life Cycle Assessment* **13** (7), 532-546.
- Sänger, M., Werther, J. and Ogada, T. (2001): NO_x and N₂O emission characteristics from fluidised bed combustion of semi-dried municipal sewage sludge. *Fuel* **80** 167-177.
- Scheidig, K., Mallon, J. and Schaaf, M. (2010): Zukunftsfähige Klärschlammverwertung (Future-proof Sewage Sludge Utilization). *Korrespondenz Abwasser, Abfall* **57** (9), 902-915.
- Scheidig, K., Mallon, J., Schaaf, M. and Riedel, R. (2013): P-Recycling-Dünger aus der Schmelzvergasung von Klärschlamm und Klärschlammmasche (Phosphorus Recycling Fertiliser from Smelting-Gasification of Sewage Sludge and Sewage Sludge Ash). *Korrespondenz Abwasser, Abfall* **60** (10), 845-850.
- Stumpf, D., Zhu, H., Heinzmann, B. and Kraume, M. (2008): Phosphorus recovery in aerated systems by MAP precipitation: Optimizing operational conditions. *Water Science and Technology* **58** (10), 1977-1983.
- Svoboda, K., Baxter, D. and Martinec, J. (2006): Nitrous oxide emissions from waste incineration. *Chemical Papers* **60** (1), 78-90.
- USGS (2015): *Phosphate rock: statistics and information. Mineral Commodity Summaries*, (http://minerals.usgs.gov/minerals/pubs/commodity/phosphate_rock/), accessed on 03.08.2015. U.S. Geological Survey,
- VDI (2012): *VDI-Richtlinie 4600: 2012-01: Kumulierter Energieaufwand - Begriffe, Berechnungsmethoden (VDI guideline 4600: 2012-01: Cumulative energy demand - Terms, definitions, methods of calculation)*. Beuth Verlag, Berlin, Germany.
- Wicht, H. (1996): *N₂O-Emissionen durch den Betrieb biologischer Kläranlagen (N₂O emissions during operation of biological wastewater treatment plants)*. Dissertation, Institut für Siedlungswasserwirtschaft, TU Braunschweig, Braunschweig, Germany.

8 Annex

8.1 Umberto® model

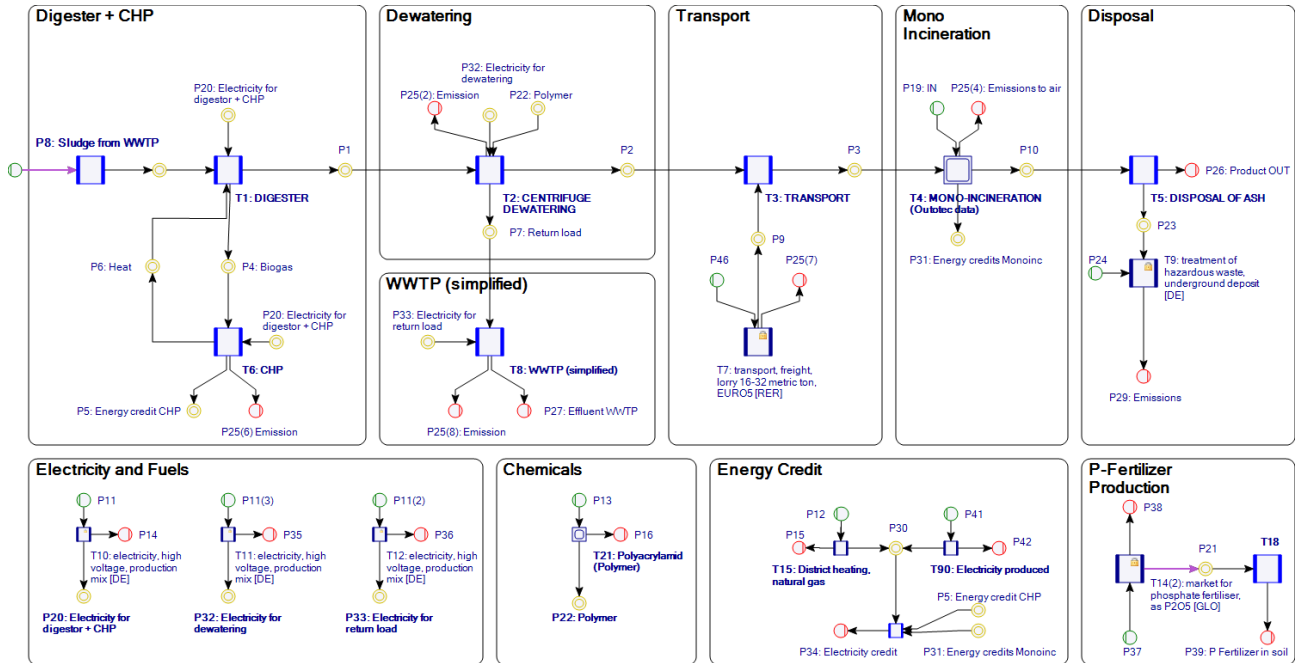

Figure 8-1: Reference scenario in Umberto NXT LCA

8.2 Infrastructure data

Table 8-1: Infrastructure data for sludge/liquor processes

Parameter		Sludge precipitation	Liquor precipitation 1	Liquor precipitation 2	Sludge leaching 1	Sludge leaching 2
Reactor size	m ³	177	72	72	72	72
Chemical storage	m ³	1x 60	2x 60	2x 60	4x 60	4x 60
Concrete	m ³	19	15	15	25	25
Reinforcing steel	t	0.6	0.7	0.7	1.1	0.5
Stainless steel	t	30	11.3	11.3	18.7	18.7

Lifetime of materials: 25a for concrete/reinforcingsteel, 15a for stainless steel

Table 8-2: Infrastructure data for processes for dried sludge or ash

Parameter		Sludge metallurgic	Ash metallurgic	Ash leaching 1	Ash leaching 2	Ash thermo-chemical
Reactor size	m ³	-	-	-	-	-
Chemical storage	m ³	-	-	3x 60	2x 60	60
Concrete	m ³	742	742	15	81	15
Reinforcing steel	t	29.7	29.7	0.7	5	0.9
Stainless steel	t	34	34	15.3	16.4	18.5

Lifetime of materials: 25a for concrete/reinforcingsteel, 15a for stainless steel

8.3 Aggregated data of Life Cycle Inventory

Aggregated inventory data for all scenarios for P recovery is presented below (Table 8-3 and Table 8-4). Data refers to the additional operational efforts and benefits of P recovery scenarios compared to the respective baseline (= Ref_EBPR or Ref_ChemP). Thus, the data describes the recovered P and N with the primary product, the additional efforts for P recovery (electricity, heat, fuels, chemicals), side effects on sludge line or mono-incineration (polymer savings, higher dewatering of sludge, reduced return load, lost energy credits due to substitution of mono-incineration, lower ash amount for disposal) and by-products (iron alloy, CaCl₂, FeCl₃)

Table 8-3: Selected annual data of Life Cycle Inventory for P recovery from sludge or liquor

		Sludge precipitation	Liquor precipitation 1	Liquor precipitation 2	Sludge leaching 1	Sludge leaching 2
P recovered	<i>t</i>	38	62	60	255	236
N recovered	<i>t</i>	17	28	27	47	107
Electricity	<i>MWh</i>	387	134	75	1'759	1'130
Heat	<i>GJ</i>	-	401	200	-	-
MgCl ₂ (30%)	<i>m³</i>	1'406	487	487	-	-
NaOH (50%)	<i>m³</i>	-	15	15	963	821
Mg(OH) ₂ (53%)	<i>m³</i>	-	-	-	56	-
MgO (100%)	<i>t</i>	-	-	-	-	355
H ₂ SO ₄ (78%)	<i>m³</i>	-	-	-	1'562	2'094
NaS (15%)	<i>m³</i>	-	-	-	1'131	-
Citric acid (50%)	<i>m³</i>	-	-	-	-	1'493
Side effects on sludge line						
Polymer (pure)	<i>t</i>	-37	0	0	1.5	0
Sludge volume to incineration	<i>m³</i>	-3'460	0	0	0	0
P return load	<i>t</i>	-66	-62	-60	-71	4
N return load	<i>t</i>	-12	-28	-27	-43	-104
Electricity for return load treatment	<i>MWh</i>	-26	-58	-56	-386	-199

Table 8-4: Selected annual data of Life Cycle Inventory for P recovery from ash

		Sludge metallurgic ¹	Ash metallurgic	Ash leaching 1	Ash leaching 2	Ash thermo- chemical ³
P recovered	t	422	422	367	508	513
Electricity	MWh	523/-2'150 ²	494	585	145	647/567 ⁴
Heat⁵	GJ	30'198/0 ²	-	-	-	4'268
Natural gas	GJ	-	-	-	-	9'514/6'439 ⁴
Coke	GJ	34'601	29'456	-	-	-
Steam	t	-	-	-	14'667	-
Ca(OH)₂ (100%)	t	-	-	1'442	147	69
H₂SO₄ (78%)	m ³	-	-	1'545	-	-
NaOH (50%)	m ³	-	-	295	-	65
NaSO₄ (100%)	t	-	-	-	-	1'708
HCl (30%)	t	-	-	-	6'437	-
Dolomite	t	560	-	-	-	-
O₂ (liquid, 100%)	t	318	178	-	-	-
IEX resin	t	-	-	-	1'418	-
By-products						
Fe slag	t	803	803	-	-	-
CaCl₂ (30%)	t	-	-	-	10'829	-
FeCl₃ (40%)	t	-	-	-	19'925	-
Side effects on mono-incineration and ash disposal						
Ash disposal	t	-5'491	-5'683	+177	-2'249 ⁶	-4'774
Net electricity⁷	MWh	+1'531	±0	±0	±0	+63
Net district heat⁷	GJ	-22'656	±0	±0	±0	-1'715

¹ including sludge drying (80% TS)

² for integrated option in MSWI plant

³ including partial drying of 6% of sludge as reducing agent

⁴ for integrated option with mono-incineration plant

⁵ for sludge drying, covered by additional natural gas

⁶ residual ash cake accounted as non-hazardous material (= inert waste)

⁷ changes in energy balance of mono-incineration = effect of full substitution of mono-incineration (Mephrec) or partial drying of sludge and direct input to P recovery process (Ash Dec)

8.4 Additional results of Life Cycle Impact Assessment

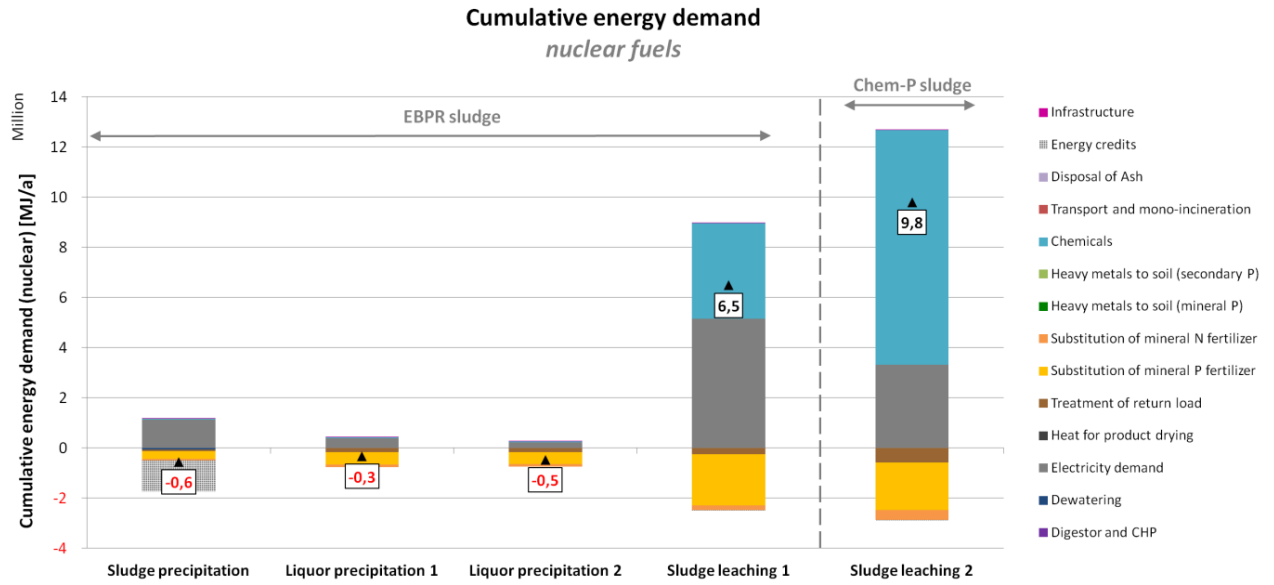

Figure 8-2: Total cumulative energy demand (nuclear) of P recovery from sludge or liquor

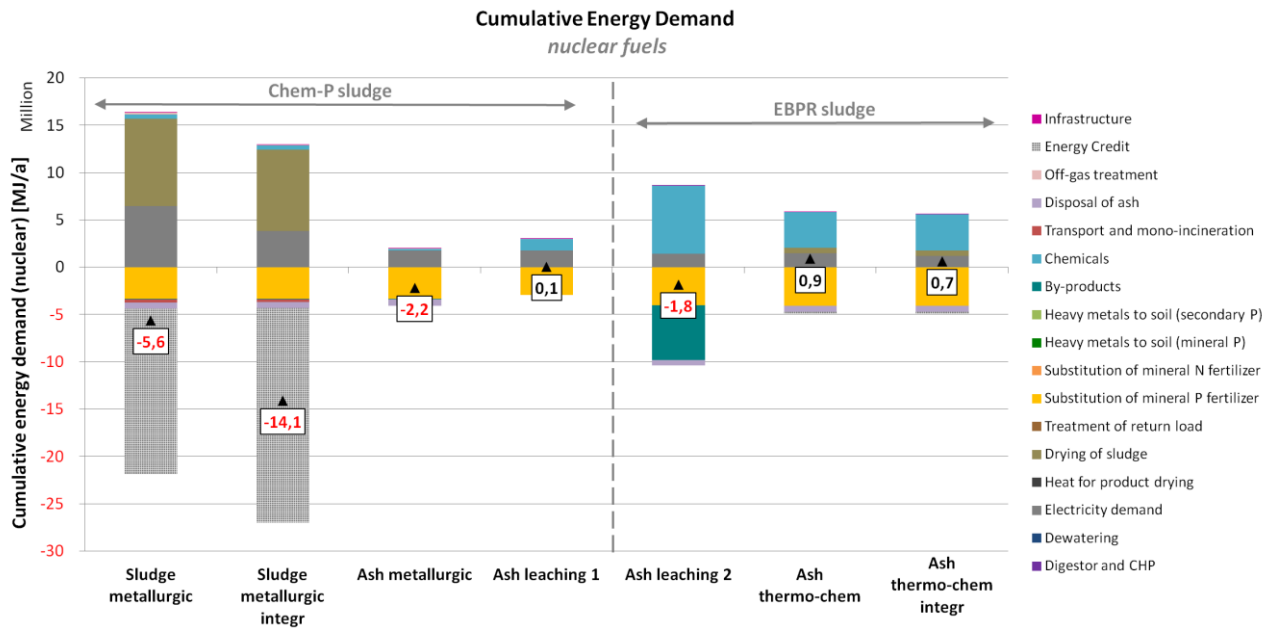

Figure 8-3: Total cumulative energy demand (nuclear) of P recovery from dried sludge or ash

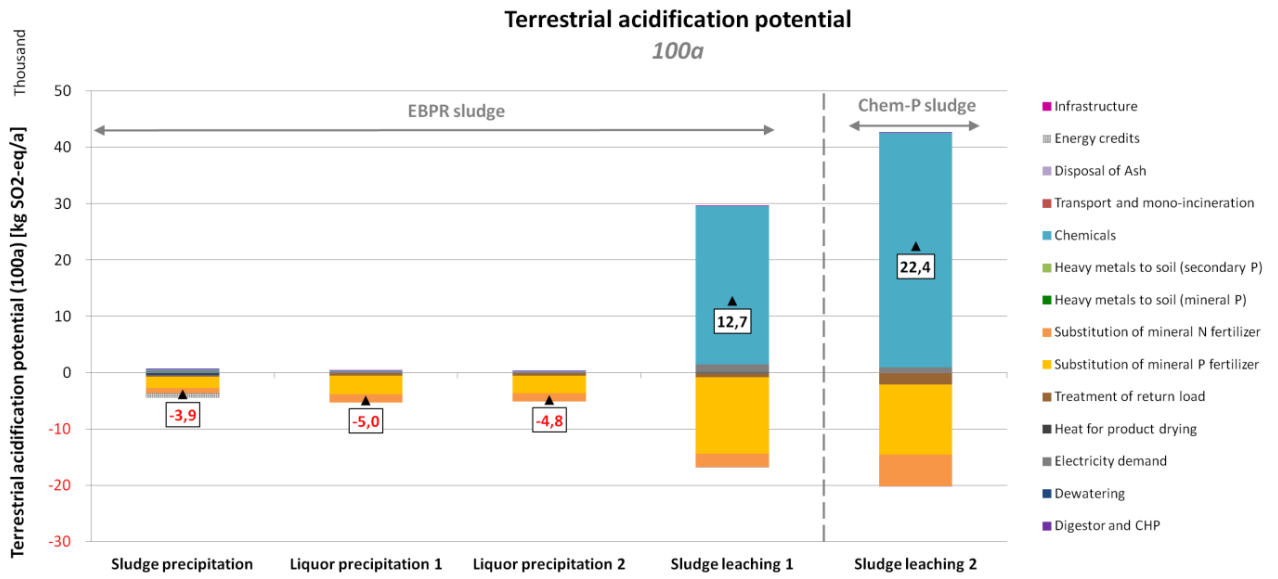

Figure 8-4: Total terrestrial acidification potential (100a) for P recovery from sludge or liquor

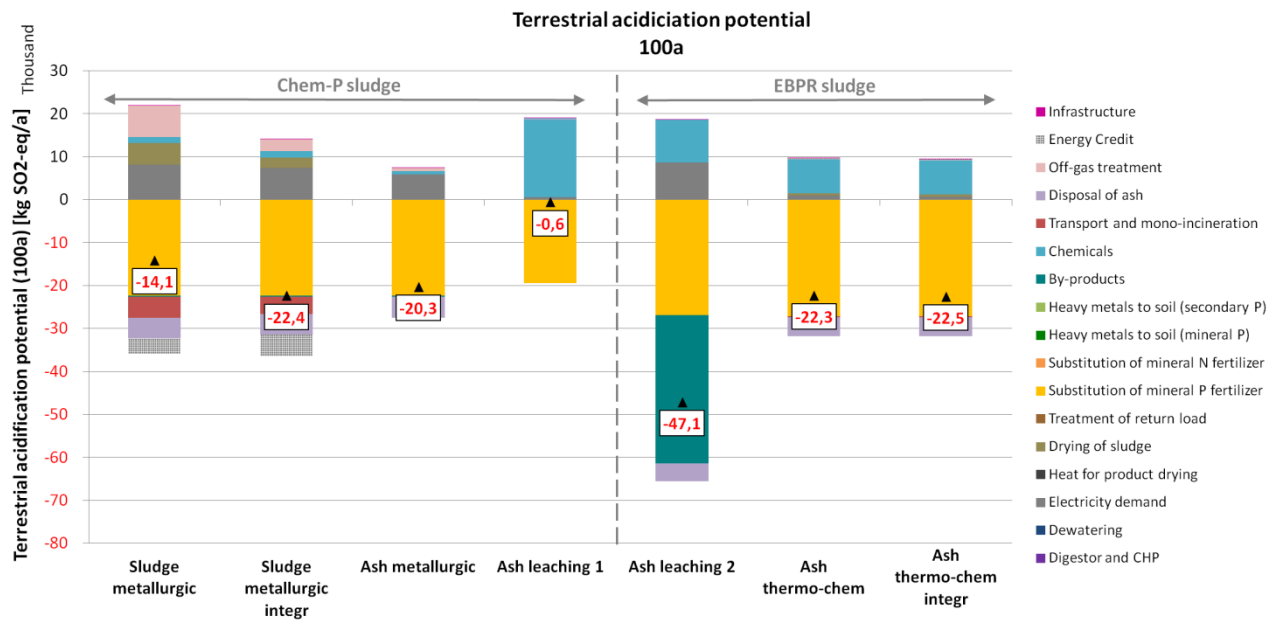

Figure 8-5: Total terrestrial acidification potential (100a) for P recovery from dried sludge or ash

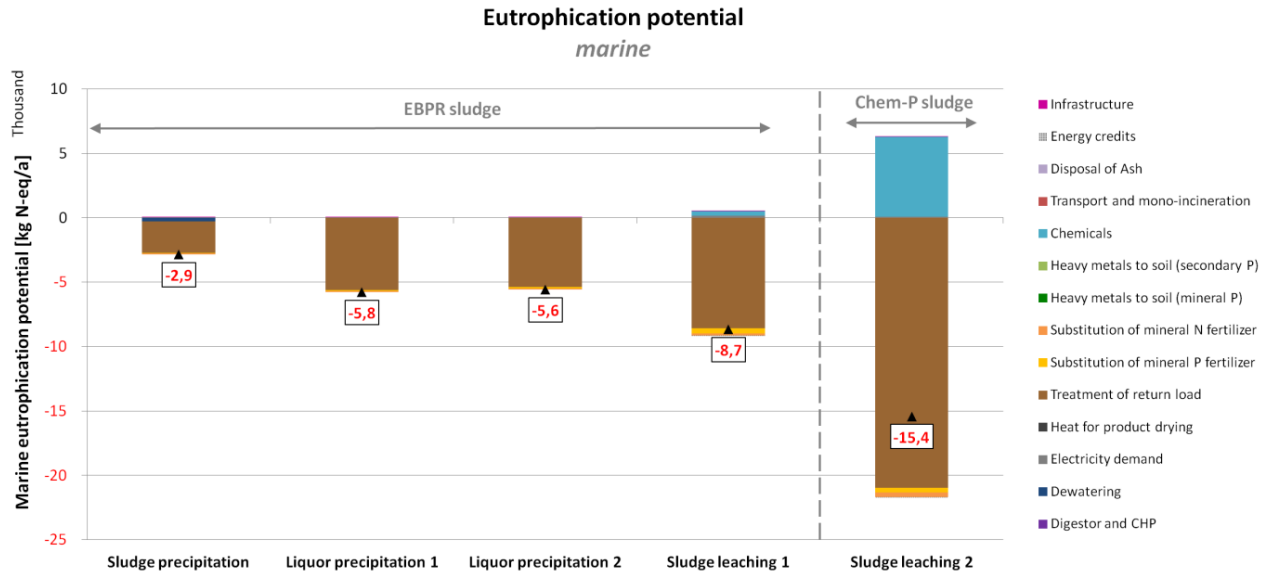

Figure 8-6: Total marine eutrophication potential for P recovery from sludge or liquor

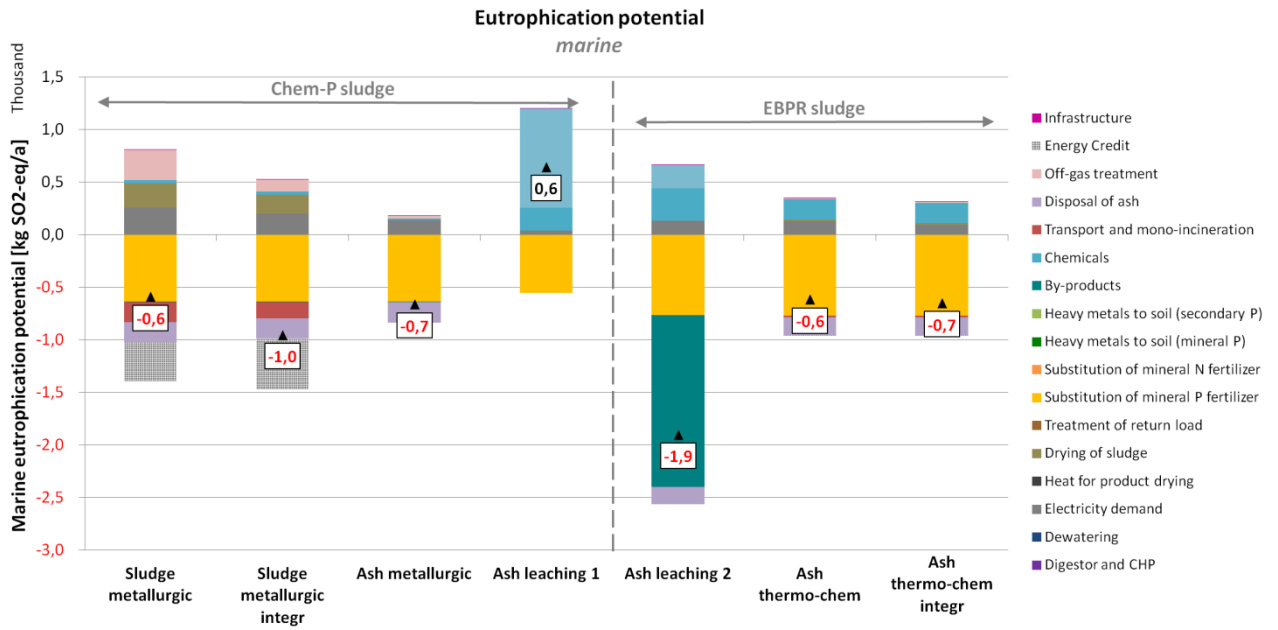

Figure 8-7: Total marine eutrophication potential for P recovery from dried sludge or ash