

LABORATORY AND PLANT

INVESTIGATIONS ON THE NATURE AND ELIMINATION OF ODORS AND DUST FROM A GARBAGE REDUCTION PLANT

By HERMANN W. MAHR AND ALVIN C. KRAFT

Received May 20, 1915

Plants and processes for treating garbage to recover grease and manufacture tankage give rise to odors and sometimes to dust of an unpleasant nature. Within the confines of New York City the nuisance from several plants for waste disposal led to protests and legal action by the health department. The municipality appointed Mr. Irwin S. Osborn, consulting waste-disposal engineer, to investigate the trouble. Mr. Osborn decided to supplement the engineering investigation with a chemical study of the nature of the odors and dust, and the present and possible means of treating them. With the cooperation of this laboratory the chemical investigation was carried out.

The odors from a reduction plant originate from the raw "green" garbage, from the processes of manufacture, and from the buildings becoming permeated with garbage and liquors. Odors from the green garbage and from some of the operations are of a local nature. Those from some treating methods are capable of causing discomfort several miles away.

Most of the work described in this paper was carried on at a works located on an island within the boundaries of New York City. The greatest inconvenience was felt by those districts on a peninsula, whose nearest point was about one mile from the disposal plant. The latter is the largest of its kind in the world, and has most of the processes typical of the smaller reduction works, and also modifications obligatory because of its size.

DESCRIPTION OF REDUCTION PROCESS

Garbage reduction may be characterized industrially, as one economically handling large quantities of very low-grade materials. The garbage arrives at the docks of the works on open scows, and is transferred to conveyor hoppers by scoop-shovels. On the conveyor it receives a rough sorting to eliminate some of the tin cans, bottles, rags, etc. The odors arising from the transportation, conveying and sorting are of a local nature, and the operations are carried on in the open air.

Conveyors deposit the garbage in large iron, brick or fire-clay lined tanks in which the material is cooked, with the addition of water, by live steam for from 10 to 12 hours. These digesters are vented from time to time, and the vent gases have considerable odor of more than local importance. Apparatus for treating these gases has been installed by the company, and a study of the odors and action of the treating appliances was a part of this investigation. The cooked garbage and liquor are run into receiving tanks and held for the presses. These receiving tanks are also vented into the devices mentioned above.

The liquor, fat, and garbage are run from the tanks to presses. The latter are of three types: flat hydraulic, in which the garbage is pressed in sacking, torpedo-shaped steam presses, in which steam pressure is depended upon, and continuous roller presses, which carry the material on metal belts through several sets of squeeze rolls. Liquid known as "stick liquor" and the grease from the presses is run to a system of settling tanks located in the open. Here the grease is skimmed off and the "stick liquor" run into the bay. "Stick liquor" has an odor probably of only local importance. At some reduction works it is evaporated in vacuum apparatus, and when of sufficient consistency mixed with the tankage. The material thus recovered adds considerably to the value of the latter.

The pressed garbage is further treated to recover the residual grease by taking it to the primary direct-heat dryers, where the remaining water is removed. The direct-heat dryers are necessary in large scale garbage treatment, steam dryers being used in many small plants. Considerable odor and dust are caused by the drying, and the odor is perceptible miles from the plant. A scrubber for the dryer gases had recently been installed. As the dryer nuisance was of great importance, it required considerable investigation in the present work. The dried garbage is conveyed to a naphtha percolating or extraction plant, where the grease is dissolved out. The naphtha solution of the grease is evaporated, first under a vacuum by means of closed steam coils and then with live steam. Extracted tankage in the percolators is treated with steam to remove the retained naphtha and then dried in a second set of direct-heat dryers known as the secondary dryers. Here, too, the drying gives rise to odor and dust which is led to the scrubber for treatment.

The dried tankage is sent to the screen house where the glass, cans, rags and bones are taken out and sorted. Considerable dust arises from the screens, but at this plant it settled within the boundaries of the works. Tankage is then stored for shipment, and its odor, which is quite mild, is confined to the store-house.

RAW MATERIAL AND LOCAL PLANT ODORS

In the above description certain odors, such as those from handling the raw garbage, from the grease separating tanks, from pressing, and from conveying garbage in the process of treatment, are characterized as of only local importance. In many reduction works, located nearer to inhabited sections, these would have to be eliminated. The transportation of garbage in open scows or cars would, in this case, be obliged to give way to closed conveyances. The handling of the garbage, both raw and in process, and other obnoxious treatments, would necessarily be carried on inside. To dispose of the odors in buildings, they should be provided with ventilating systems drawing the air through scrubbers and afterward through de-

vices for perfuming it with wood-tar oils. Systems similar to this are successfully used in treating packing-house air.

DIGESTER-VENT ODORS AND GASES

During the cooking of garbage the digesters are vented through a by-pass around the valve of the main outlet pipe. This operation has two objects: (1) to drive out air at the beginning of the cooking, and

At the beginning of the sampling, bottle *D*, filled with water, was connected to the condenser, and the uncondensable gases allowed to displace the water through the siphon. When the water had been completely displaced the siphon was shut off, and the bottle *E*, full of water, connected to *D*. Condensate from the vent line was then collected in *D*, and the uncondensable gases in *E*. During the sampling

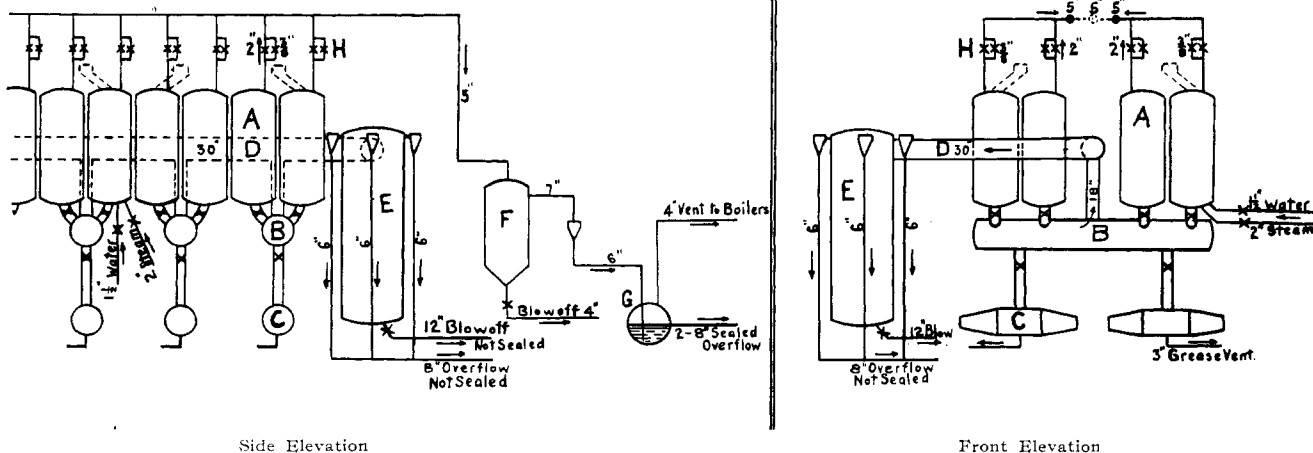

FIG. I—DIGESTERS AND VENT TREATING APPARATUS

- A—Digester, with Feeding Chutes
- B—Receiving Tank
- C—Steam Presses
- D—Receiving Tank Vent
- E—Vent Tank with Condensers
- F—Digester Vent Tank with Condensers
- G—Blowoff Tank
- H—Digester Vent By-Pass

(2) to insure good circulation of the cook. The receiving tanks are also vented, and the gases from both operations treated in the same sort of apparatus. Fig. I is a diagrammatic representation of digesters, tanks and vent-odor eliminating appliances. The steam and gases pass to tanks *E* and *F*, which serve as catch tanks in the event of a digester boiling over. They are then conducted to barometric condensers, fed with sea water, where the steam and the condensable constituents are condensed. The end of the condensers, from digester vents, runs into a tank, *G*, the water and uncondensable gases here separating; the former escape through a sealed overflow to the bay, and the gases are conducted to behind the bridge wall of the boiler furnaces for heat treatment. The water and gas from the receiving-tank condensers are conducted directly to the bay.

the average temperature in the vent line was found to be 101° C.

SUBSTANCES CARRIED OVER MECHANICALLY—An examination of the solids in the condensate was carried out by evaporating in a platinum dish, drying and igniting, with the following results:

PER CENT SOLIDS	In unfiltered condensate	In solution	In suspension
Total.....	0.0224	0.0102	0.0122
Inorganic.....	0.0083	0.0067	0.0016
Organic.....	0.0141	0.0035	0.0106

These results show that two-thirds of the soluble materials carried over mechanically with the vent steam are inorganic. It will be shown below that a

The investigation of the digester-venting included a study of the chemical nature of the condensable substances and odors eliminated by the barometric condensers. These condensable constituents fall into two classes: (1) substances mechanically entrained by steam, and (2) those volatile in the form of vapor. Closely connected with the proceeding was a determination of the chemical nature of the gases escaping condensation in the treating apparatus. Experiments on deodorizing the water from the condensers and the uncondensable vent gases were also made.

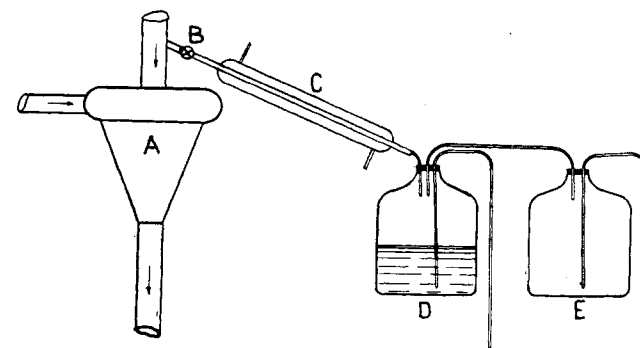

FIG. II—SAMPLING APPARATUS, ABOVE BAROMETRIC CONDENSERS
A—Barometric Condenser B—Sampling Control Valve
C—Condenser D—Condensate Sample E—Gas Sample

THE CHEMICAL NATURE OF CONDENSABLE VENT SUBSTANCES

Information regarding the condensable substances in the vent gases was obtained from samples of condensate of the vapors taken at a point before entering the barometric condensers, as shown in Fig. II.

large part of the organic matter, thus taken from the digesters, consists of fats and fatty acids. None of the substances carried over mechanically are of importance from the odor standpoint.

CONDENSABLE VOLATILE SUBSTANCES, on the contrary, are of considerable importance as odor pro-

ducers. The condensate was filtered, and the specific gravity taken and found to be 0.9967, thus pointing to the presence of *ethyl alcohol* to the amount of 1.87 per cent by weight. On distilling, to concentrate, the characteristic bead-like drops caused by alcohol condensation were noticed in the condenser and the distillate gave the iodoform reaction for alcohols.

ACIDS in the condensate were determined by titration with alkali, using phenolphthalein as an indicator, and found to be equivalent to 0.0851 per cent, calculated as acetic acid. A 100 cc. sample of condensate was placed in an apparatus for determining carbon dioxide in carbonates by the evolution method, and boiled while a current of air was led through the apparatus. The steam and steam-volatile acids were condensed by the reflux condenser of the apparatus, while any carbon dioxide was conducted through drying tubes to a weighed potash absorption bulb. It was found that the amount of carbon dioxide present was practically *nil*.

ACETIC ACID AND OTHER STEAM-VOLATILE ACIDS were found by steam-distilling the condensate and titrating the distillate. The results gave 0.0792 per cent of steam-volatile acids, calculated as acetic. Part of this was acetic acid and part steam-volatile fatty acids. The remaining non-volatile acidity was probably due to non-volatile fatty acids carried over mechanically.

The acidity of the vent gases has an important bearing on the corrosion of the vent pipe lines.

SAPONIFIABLE SUBSTANCES in the condensate were estimated by neutralizing a portion of it, and then saponifying with standard alcoholic potash; 100 cc. of condensate required 103.6 mg. of potassium hydrate for saponification. Some of the neutralized condensate was then steam-distilled. The surface of the distillate was covered with oily drops, and the distillate from 100 cc. of condensate required 79.5 mg. of potassium hydrate for its saponification. The volatile saponifiable substances were therefore apparently *essential oils*. This supposition was confirmed by a test for aldehydic constituents of essential oils in the distillate, by means of fuchsine reagent. The residue from the steam distillation was extracted with ethyl ether, and after evaporating off the latter, a fatty residue remained. The saponifiable substances in the condensate were thus proven to be steam-volatile essential oils and mechanically entrained fats.

On boiling the condensate and passing the vapors through lead acetate paper a test for sulfur compounds was obtained.

The *indol* test for bacterial decomposition products gave negative results.

CONCLUSIONS—The mechanically carried over substances removed by the condensers are principally mineral matter, fats and fatty acids. The volatile substances in the vent gases which are condensable or absorbable in water include alcohol, acetic acid, carbon dioxide, essential oils and sulfur compounds. Of these constituents, the two latter are important from the odor standpoint, and impart their smell to

the condensing water passing through the jet condensers.

UNCONDENSABLE VENT GASES

The uncondensable vent gases were examined before and after passing the barometric condenser. Samples of the former were obtained at the same time the condensate was sampled. The gases after passing the condenser were sampled from the vent pipe to the boiler by displacement (*G*, Fig. I). Simultaneous samples before and after passing the barometric condensers gave the following results:

UNCONDENSABLE VENT GASES AT BAROMETRIC CONDENSERS		
	Before passing	After passing
Carbon dioxide.....	45.2 per cent	6.2 per cent
Oxygen.....	10.8 per cent	18.0 per cent
Sulfur compounds.....	Large amount present	Large amount present

The sulfur compounds were tested for in a solution of bromine water through which the gases had been conducted. The decrease in the carbon dioxide content, as a result of passing through the barometric condenser, is an indication of the efficiency with which the condensers are absorbing the condensable gases. The extremely nauseating odor of the uncondensable vent gases appears to be due to sulfur compounds and other non-sulfur containing substances, possibly essential oils. It will be shown below that the presence of the sulfur compounds is important in determining the method of treatment for the gases.

EXPERIMENTS ON THE ELIMINATION OF VENT ODORS

The *water leaving the barometric condensers* has considerable smell. Water containing the condensable odorous vent substances was quickly deodorized by small amounts of sodium and calcium hypochlorite. The location of the reduction works in question, on the sea, makes possible a practical application of this treatment. Sea water could be electrolyzed and run into the condenser water before it enters the condensers.

To investigate the efficiency of water in eliminating the uncondensable gases by further scrubbing, some of the gas from tank *G* was led through 100 cc. of water in a small Erlenmeyer flask at the rate of about five bubbles per second. The gas was metered through a wet test meter and after about 0.2 cu. ft. of gas had passed through the water the odor of the vent gas was noticeable.

Some of the gases were then led through sodium hypochlorite solution containing 4 parts of available chlorine in 1000. The rate was also about five bubbles per second, and the volume of solution 150 cc.; 10 cu. ft. of uncondensable vent gas were passed through the solution before its odor was apparent. Calcium hypochlorite (chloride of lime) solution was also found to be a good deodorizer.

The strength of sodium hypochlorite necessary to deodorize was determined by leading the gases through solutions containing various amounts of available chlorine. A strength of 1 part of available chlorine in 1,000 was necessary for a decided deodorizing action.

In applying to condenser water the treatment with electrolyzed sea water, mentioned above, the uncondensable vent gases would be deodorized as they

passed through the condenser and vent tank *G* (Fig. 1). Of course, steps would have to be taken to insure the presence of sufficient hypochlorite.

A possible method of combining the condensing and deodorization treatment would be by means of surface condensers. The volume of odorous liquids requiring treatment with chemicals would be reduced greatly in comparison with that at present passing through the jet condensers.

HEAT is a favorite agent for eliminating odors, and uncondensable vent gases from garbage digesters are often treated thus. As was mentioned above, this method is in use at the plant under consideration.

Mr. Osborn¹ and Prof. Crowe studied the action of heat on the uncondensable vent gases from the Municipal Reduction Works at Columbus, Ohio, in 1911. They led the gases through a heated copper tube provided with a temperature-recording device, and then through the water jet pumps, which furnished suction.

They concluded that heating the vent gases to 1600° F. completely destroyed the odor.

In the present study the uncondensable vent gases were led from tank *G* to a bottle for equalizing and observing the pressure and thence to a Hoskins electric tube furnace containing a heated silica tube. The furnace was provided with a rheostat and the temperature determined by means of a pyrometer. The couple of the latter was inserted so that the hot junction was in the center of the heated gas. Pressure in the vent tank made the use of suction unnecessary. The odor of the gases after heating was observed at the end of the silica tube with the results given below:

EFFECT OF HEATING ON THE ODOR OF DIGESTIVE-VENT GASES

Temp. in furnace	Temp. of gases at point where odor was noted	NATURE OF ODOR
40° F.	40° F.	Sweet, slightly nauseating, essential oil like
150	66	Sweet, slightly nauseating, slightly acrid
250	86	
350	118	Sweet, slightly acrid, slightly irritating
450	114	Less sweet, acrid, slightly irritating
550	169	No sweetness, quite acrid and irritating
750	176	Acrid, irritating, SO ₂ odor apparent
850	194	
950	201	More acrid and irritating, SO ₂ odor very distinct
1050	205	
1100	233	Very acrid and irritating, SO ₂ odor very distinct
1150	230	
1200	239	Increase in irritating, pungent, SO ₂ odor
From 1200 to 2000	...	

The presence of sulfur dioxide in the heated gases was confirmed by passing them into bromine water and adding barium chloride.

To ascertain whether the copper tube used by Osborn and Crowe was a factor in destroying the vent gas odor, a heating experiment similar to the first was run and a layer of copper oxide was placed in the heated zone of the silica tube. The results were practically the same as those when the plain silica tube was employed. Osborn and Crowe's conclusion regarding the effect of heating on the vent gases was therefore not substantiated by these experiments.

All garbage digester odor was shown to disappear at a temperature of 700 to 800° F., giving place to the odor of sulfur dioxide, formed from the sulfur com-

pounds in the gas. The vent odor was apparently completely replaced by that of sulfur dioxide at temperatures of 1100 to 1200° F. A study of the apparatus used by Osborn and Crowe led to the conclusion that the action of water, in their jet suction pump, had been an important factor in eliminating the sulfur dioxide in the gases after heating.

An experiment in which the gases were heated to about 1200° F. in the silica tube and then bubbled through water showed the washed gas to be without odor of any sort.

These experiments show that the generally used heating method (without subsequent scrubbing with water) for treating uncondensable digester-vent gases is inadequate. It results in forming a gas which is almost as obnoxious and probably more harmful than that from which it originated. One practical method of treating the gases at the present plant would be to send them through the fires of the direct heat dryers and then to the scrubber for washing the dryer gases.

A method of deodorizing packing-house air by means of sulfur dioxide has been said to give good results. It is possible that the sulfur dioxide, formed by heating the vent gases, could be reconducted to the jet condensers, and in this way a deodorization of the condenser water brought about.

That the sulfur compounds are the interfering factor in preventing deodorization by simple heating of the vent gases was confirmed by similar heating experiments on "stick" roll gases at a plant for treating offal, located near the garbage plant. The "stick" rolls are steam-heated drums on which concentrated liquor, obtained by evaporating the water from offal digesters, is dried. When the gas from these rolls was heated to 1200° F. the odor was completely destroyed and a test showed it to be free from sulfur compounds.

Objectionable odors are often masked by treatment with *coal-* or *pine-tar*. The odor of uncondensable vent gases, when led through a bottle containing pine tar oil, gave way completely to that of the tar oil.

GASES, DUST AND ODOR FROM THE DRYERS

When the reduction process was outlined, mention was made of the far-reaching effect of the odors from drying garbage and tankage in direct heat dryers. At this disposal works the process required two dryings, one of the cooked garbage, known as the primary drying, and a drying of the degreased material, which contains water from the steam used to displace the naphtha residues. The latter is designated as secondary drying. The dryers are cylindrical, about 25 ft. long, 5 ft. in diameter, and made of sheet steel. They are rotated in a manner similar to a tube furnace, but at a much greater speed. The heating is by means of hand-fed coal fires with a forced draft, each dryer having its own furnace.

The garbage is fed into the furnace end of the dryer from a room located above it. On arriving in the dryer the garbage at once comes into contact with the

¹ Private communication.

flame, resulting in a quick drying, with some burning, which gives rise to a large part of the dryer odor. The object of feeding at the heated end of the dryer is to obtain a fairly well dried material, which will not stick to the dryer as it proceeds to the outlet end. As the garbage becomes dried, the fast rotation, aided by the high draft, carries off considerable dust, which, with the dryer odor, was a source of annoyance to the surrounding communities.

The gases and dust leave the end of the dryers in the dust rooms shown in Fig. III and then pass through a brick flue. The dust rooms have many openings through which air enters to dilute the dryer gas, and the amount of this dilution has a bearing on the treatment of the gases. From the flue the gas is diverted into a scrubber which has recently been installed, and after being washed returns to the flue and thence to the chimney. Fig. III also shows the arrangement of the scrubber. The nozzles form a spray curtain through which the gas passes. Sea

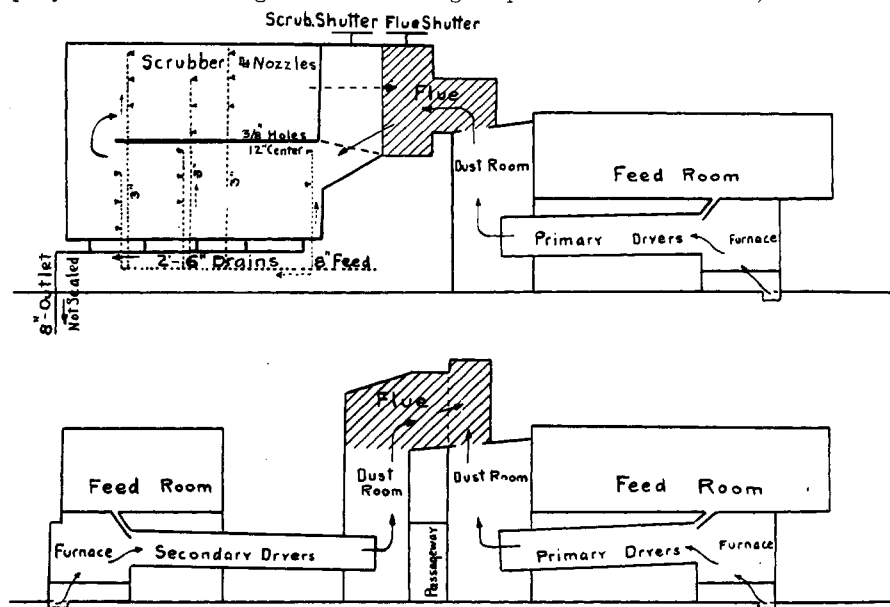

FIG. III—DRYERS AND SCRUBBER

water is used in the scrubber, after it has been used for cooling in the naphtha recovery plant. Considerable care is exercised to keep the scrubber water free from mechanical impurities which would clog the nozzles.

The first determination in this section of the work was one of the velocity and volume of the dryer gases passing to the stack. To ascertain if the amount of gas treated by the scrubber could be decreased, an estimation of the dilution of the gases by leakage was made. The value of the scrubber in removing dust was found by dust determinations before and after scrubbing the gases. The chemical nature of the odor of the dryer gases was investigated in order to select constituents which could be determined before and after scrubbing, in this way testing the efficiency of the scrubber as an odor eliminator. The dryer studies were completed with experiments on methods of deodorizing the gases.

THE VELOCITY OF THE DRYER GASES was determined

in the main flue, opposite the scrubber entrance. The latter and the scrubber exit were walled off from the flue for the purpose of the determination. Use was made of the standard pitot tube of the American Blower Company and the method described by Rouse.¹

Owing to the large size of the flue (width 5 ft. 9 in.; depth 17 ft. 2 in.), means of lengthening the tube were necessary. The end section of the pitot tube was soldered into a reducer on the end of an iron pipe. The pitot tube connections were soldered to copper pipe, which ran through the iron pipe to rubber connections from the manometer. In order to keep the pitot cool, water could be conducted through the iron casing pipe. Fig. IV is a photograph of the pitot tube and observation station.

The width of the flue was divided into 5 and the depth into 10 equal parts; readings were taken at the center of each of the fifty rectangles thus formed. During the tests observations on the number of dryers in action, revolutions per minute of the blowers, draft in the latter, in the flue, in the dust chambers, and flue temperatures were made. Moisture determinations on the flue gas were also run by drawing it through the steam-jacketed tube, described below, and absorbing in calcium chloride. Results of two runs showed a velocity of 30.446 and 27.705 ft. per second under flue conditions of temperature. From the latter results the volume of gas passing through the flue was found to be 2735 cu. ft. per second.

The question of whether the gas leaving the dryers was diluted by leakage from the air, entered into the engineering study. This had a bearing on the amount of gas which could be efficiently scrubbed by the present apparatus. Analyses were made of the gas leaving the

dryers and of that entering the scrubber. Calculations based on the carbon dioxide content showed the dilution to vary from 1-1.9 to 1-3.9 volumes.

EFFICIENCY OF THE SCRUBBER IN REMOVING DUST

To determine the amount of dust being removed by the scrubber, estimations of the amount in the flue gases before and after scrubbing were required. Because of the size of the dust particles, and particularly the amount of moisture in the gas, considerable study and experimentation were necessary to evolve a satisfactory method. It was decided to use the principles and apparatus of Brady and Touzalin,² and the latest form of their apparatus was first employed. The sampling tube was found to be of too small a bore for this work; it soon clogged because of the moisture, large amount of dust and size of the dust particles.

¹ *J. Am. Soc. Mech. Eng.*, Sept., 1913; see also Fairlie, *THIS JOURNAL*, 1914, 583.

² "The Determination of Dust in Blast Furnace Gases," *THIS JOURNAL*, 3 (1911), 662.

A much larger bore tube ($\frac{3}{8}$ in.) was made and steam-jacketed (see Fig. V) to avoid condensation. To obtain correct results, according to the above authors, the velocity of the gas withdrawn through the sampling tube must be the same as that in the flue proper. In their original method the flue velocity was ascer-

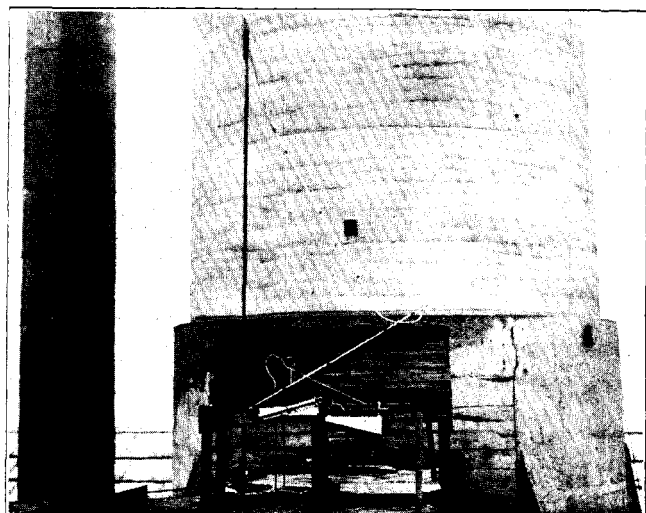

FIG. IV—MODIFIED PITOT TUBE

tained with a pitot tube, and the sample metered so as to maintain this velocity in the sample tube. In their improved apparatus¹ a side tube leads from a point in and near the entrance to the sampling tube to one arm of an Ellison gauge. The other arm of the gauge leads to a tube with its opening into the flue near the intake of the sampling tube. The latter is turned so that the opening is in the plane of the flue gas stream. The pressure on these tube ends is the static pressure of the gas flowing past them. By connecting one to each side of an Ellison gauge, and regulating the speed of sampling so that the levels of the liquids in both arms remain equal, the essential condition of equal velocities in the flue and sampling tube is attained. This modified pitot tube device was added to our new sampling tube.

To maintain equal velocity in the flue and large sampling tube, required the metering of volumes of gas so large as to be greater than the capacity of the wet test meter accompanying the Brady apparatus. A standardized 20-light dry meter was therefore employed. The nature of the dust, and its large amount, soon clogged the Brady paper filters and made impossible the maintenance of the requisite sampling velocity. Filters of 200-mesh wire gauze were therefore used. The filter was enclosed in a chamber heated by steam coils, the electric heater of the original apparatus having proved inadequate under conditions of the present work.

Some dust escaped the gauze filters and this was caught by scrubbing in two large baffle wash bottles²

¹ Private communication from Mr. Brady.

² These bottles were first used in an investigation of the amount of sulfur dioxide in the air of one of the sections of this city, when a study of nuisance from a number of industrial plants was made. At that time they were found to work without entrainment when 10 cu. ft. of air per minute were washed, although in the present work the rate was only one cu. ft. per minute.

(Fig. VI) made from two-liter wide-mouthed bottles, into which were ground stoppers with the entrance and exit tubes. The entrance tube was provided with perforated glass baffle plates extending nearly to its sides. The lower plate was under the water level and helped break up the gas and at the same time kept the water from being lifted too high when large amounts of gas were washed. The upper plate prevented the carrying away of the liquid mechanically.

The dust determining apparatus was set up as shown in Fig. VII. In carrying out the determination a dried and weighed gauze filter was placed on the end of the sampling tube and from 20 to 30 ft. of gas led through the apparatus. The latter was then taken apart, and the connections, from C on, washed into the bottle D. No dust was ever found in the sampling tube. The filter and dust were dried and weighed, and the dust in the wash bottles determined by filtering on a Gooch crucible. The volume of the gas recorded by the meter was calculated to a temperature of 15.5° C.

The dust was determined in the flue with the scrubber walled off, and in the exit of the scrubber at the left and right side of the damper. Samples were taken at the latter points with the water shut off in the scrubber, and also with water on. The following table gives results of the dust determinations:

No. of run	Scrubber	Gas(a) filtered Cu. ft.	DUST DETERMINATIONS		Length of run Min.	Test point
			Total dust Grams	Dust per cu. ft. of gas(a) Gram		
1	off	6.39	0.571	0.0893	11	Left side of scrubber damper facing stack
2	off	21.28	1.625	0.0764	28	
3	off	13.28	1.015	0.0766	27	
4	on	30.08	0.272	0.0096	40	
5	on	38.63	0.335	0.0087	36	
6	off	17.13	1.162	0.0678	19	Right side of scrubber damper facing stack
7	off	26.06	2.203	0.0846	34	
8	off	34.57	2.609	0.0755	43	
9	on	20.63	0.122	0.0059	27	
10	on	23.87	0.089	0.0037	37	
13	on	19.77	1.485	0.0751	20	In dryer flue just before entering stack (scrubber walled off)
14	on	27.87	1.989	0.0714	25	

Av. wt. of dust per cu. ft. of gas, scrubber off..... 0.077 g.

Av. wt. of dust per cu. ft. of gas, scrubber on..... 0.007

Av. wt. of dust per cu. ft. of gas, removed by scrubbing..... 0.070

(a) Gas at 15.5° C. at 29.92 in mercury pressure.

These results show that 91 per cent of the total dust in the dryer gases is removed by the scrubber.

The amount of dust removed from the gas by the scrubber was also calculated from determinations of the dust in the water entering and leaving scrubber. In order to do this the amount of water delivered to the scrubber was obtained from the number of strokes and size of the pump. Using the volume of gas passing into the scrubber found by the pitot tube observations and the foregoing data, two runs gave 0.0832 and 0.0805 g. of dust removed from a cu. ft. of gas. This is a fair check on the direct determinations, considering the assumptions and possible variables in the second method.

ODOROUS SUBSTANCES IN DRYER GASES AND EFFICIENCY OF SCRUBBER AS AN ODOR ELIMINATOR

To determine the efficiency of the scrubber as an eliminator of odors, it was necessary first to ascertain the odorous substances present, whose nature would permit quantitative chemical determination. The analysis of the flue gas just mentioned showed car-

bon monoxide and carbon dioxide, but these substances could not be regarded as important from the odor standpoint.

After a number of attempts to isolate possible constituents, some of the water used for scrubbing in the dust determinations was made acid with phosphoric acid and distilled. The distillate was condensed, the end of the condenser tube dipping into water in the receiving vessel. The distillate had a sharp burnt odor. On titrating with alkali considerable acid was found. The carbon dioxide in the neutralized distillate was determined by evolution. It was found that about 80 per cent of the acidity of this distillate was due to carbon dioxide. The presence of so much of this odorless gas in the distillate

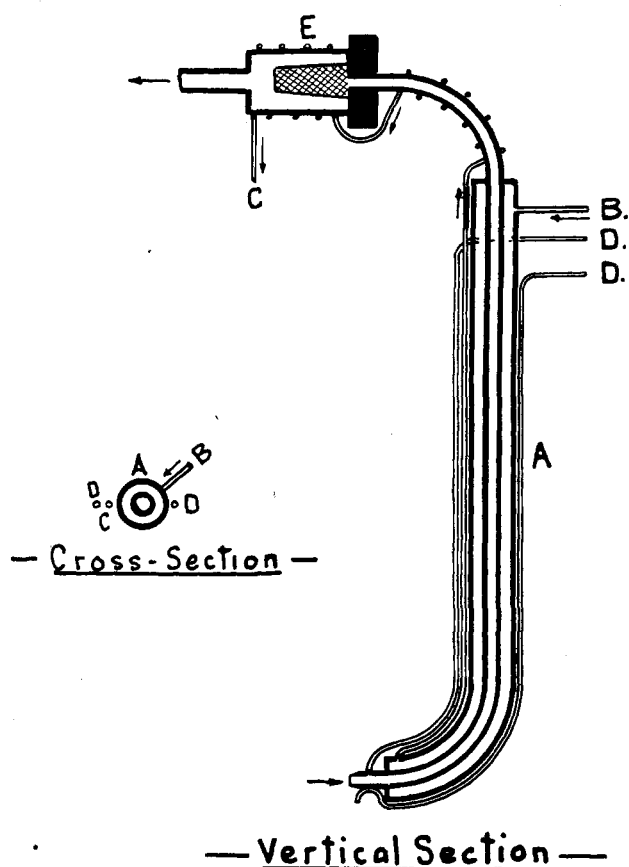

FIG. V—SAMPLING TUBE AND FILTER, SHOWING STEAM JACKET
A—Sampling Tube B—Feed Steam C—Exhaust Steam
D—Pitot Connections to Ellison Gauge E—Wire Gauze Dust Filter

of the volatile acid substances made the determination of the efficiency of the scrubber by this means inadvisable.

Some of the dust scrubber water was then made alkaline with sodium hydrate and distilled in the same manner. The distillate containing the volatile alkaline constituents of the dryer gas had a strong pyridine odor and was alkaline. The number of cc. of $N/10$ acid necessary to neutralize these substances were obtained by titration, using methyl orange. On Nesslerizing, ammonia was also found in the distillate. The amount of volatile alkaline constituents in the dryer gas was selected as a means

of ascertaining the performance of the scrubber as an odor eliminator.

Efficiency determinations were carried out by drawing the gas through dilute sulfuric acid, using the dust determining apparatus. In this case a gauze dust filter was placed over the entrance of the sampling tube. An aliquot part of the total volume of the acid solutions from both bottles was taken for distilling. This was made alkaline with sodium hydrate and distilled from a Thompson flask, used for determining acetic acid in white lead. The end of the condenser dipped into water containing standard acid. Methyl orange was used as an indicator in titrating back. All results were expressed in cc. of $N/10$ acid required to neutralize the volatile alkaline constituents in 100 cu. ft. of gas.

A test with the scrubber off required 89 cc. $N/10$ acid per 100 cu. ft., and with the scrubber working under the most perfect conditions 26 cc. $N/10$ acid. From this it follows that the scrubber has an efficiency of about 70 per cent in eliminating odorous substances from the dryer gases.

CONCLUSIONS—The scrubber under present conditions of working eliminates practically all the dust in the dryer gases. By excluding the air now leaking into these gases the volume of gas to be scrubbed could probably be much lessened and all the dust removed. Considerable dryer odor now escapes with the scrubber at its utmost capacity. It will be shown

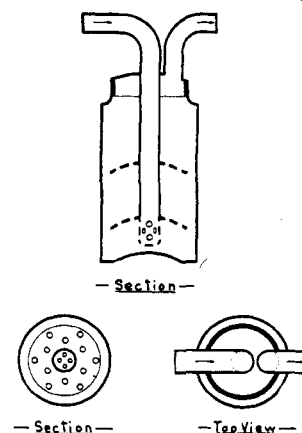

FIG. VI—BAFFLE WASH BOTTLE WITH GROUND JOINT

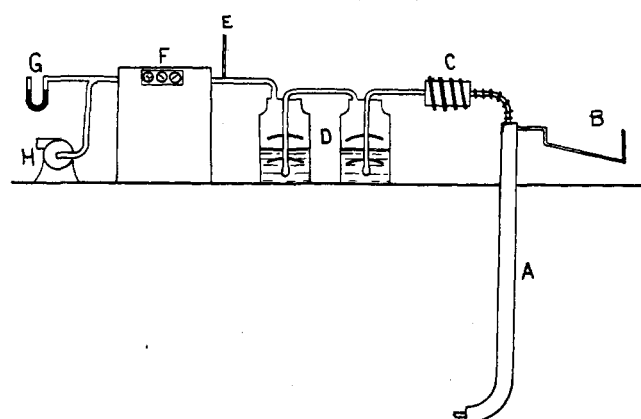

FIG. VII—DUST DETERMINATION APPARATUS
A—Sampling Tube (See Detail) E—Thermometer
B—Ellison Gauge F—Gas Meter (Dry Type)
C—Dust Filter (See Detail) G—Pressure Gauge
D—Baffle Wash Bottles (See Detail) H—Centrifugal Fan

below that the odors can be completely removed by water. Decreasing the air leakage, as mentioned, would allow a more efficient scrubbing under the present working conditions. To thoroughly eliminate the dust and odor it would be advisable to increase the efficiency of the scrubber.

EXPERIMENTS ON THE DEODORIZATION OF DRYER GASES

On passing dryer gas through several bottles of water its odor was practically all removed. In the same way the odor was destroyed by means of a solution of calcium hypochlorite (bleaching powder) containing 1 part of available chlorine in 1000. By leading the gas across *pine tar oil* its characteristic smell was replaced by that of the oil. The latter result suggested that mineral oil of the paraffin oil or light engine oil class might have sufficient solvent effect on the odorous substances to make their use in a scrubber possible. The effect of mineral oil was not investigated because of lack of time.

The action of heat on dryer gas was observed using the same apparatus as for the digester gas. It was in this case necessary to draw the gas through the tube furnace. The results are given below:

EFFECT OF HEAT ON THE ODOR OF DRYER GASES		
Temp. in furnace ° F.	Temp. of gases at point where odor was noted	NATURE OF ODOR
40	40° F.	Slightly burned
150	52	Sweet, slightly irritating, burned
250	60	
350	72	
450	86	
550	86	Irritating, acrid, slightly burned
650	86	
750	84	Very irritating, acrid, burned
850	100	
950	95	
1050	93	Very irritating but not quite so burned
1150	116	
1250	120	
1350	116	Not quite so irritating or acrid, only slightly burned
1450	122	
1550	129	Only slightly irritating and acrid, no burned odor
1650	147	Less irritating than at 1550° F.
1750	154	Practically no irritating odor
1850	163	No odor of any kind

No sulfur compounds were present in these gases.

Experiments were made to ascertain if dilution with air, before leaving the stack, could be carried to such a degree that the dryer odor would be unperceptible. Gas and air were passed separately through meters and then mixed in a 4 ft. length of 1/2 in. tube, and the odor noted. The data obtained follows:

Rate of flow, cu. ft. per min.	Dilution of dryer gas to air	Intensity of dryer gas odor
Dryer gas	Air	
0.6	12	1 : 20 Very strong
0.2	12	1 : 60 Strong
0.031	12	1 : 400 Distinct

The results show that no reasonable amount of dilution with air is effective in causing the dryer gas odor to become negligible.

ODORS ARISING FROM PERMEATION OF THE REDUCTION WORKS STRUCTURE WITH LIQUIDS, ETC.

Brief mention may be made of the odors resulting from the permeation of the buildings of reduction works with liquids, etc. The wind passing over the plant may in this way take up considerable odor, even when no garbage is present or in process. To eliminate this source of trouble garbage plants should be of the most sanitary construction to permit washing and prevent material lodging in crevices. The cement of concrete floors is readily attacked by the stick liquor and garbage, and wooden floors are sometimes put down. As may be easily understood, these soon become of a very objectionable nature and can-

not be cleaned. A concrete floor with a frequent renewed tar coat or one of asphalt would be a great improvement on the wood.

In conclusion, we wish to acknowledge our indebtedness to Mr. Osborn for his invaluable suggestions, advice and inspiring interest in this investigation. We also wish to thank Mr. Thomas D. Banks, Superintendent of the Garbage Reduction Plant of Columbus, O., for valuable assistance, and Mr. George Wood, Assistant Engineer in the Department of Street Cleaning of this city, for aid in carrying out the experimental work and for the sketches accompanying this paper. To Mr. Charles Crew, of this laboratory, we are grateful for the performance of analytical determinations.

CENTRAL TESTING LABORATORY
CITY OF NEW YORK

TWO CONVENIENT FORMS OF RECEIVER FOR FRACTIONAL DISTILLATIONS UNDER DIMINISHED PRESSURE

By MARSTON TAYLOR BOGERT
Received June 16, 1915

Having had occasion recently to carry out many fractional distillations of two or three liters of liquid at a time, under reduced pressure, the writer could not find upon the market any form of receiver which would permit the taking of a large number of fractions, of varying volume, without interruption of the distillation. To meet this need, the forms described below were devised and have proven very serviceable. Possibly, other chemists confronted with similar problems, also may find them of use.

APPARATUS I is constructed entirely of glass resistant to the action of chemicals, well tempered, and sufficiently strong to withstand the full atmospheric pressure. Ordinarily, the connections with the end of the condenser (or distilling tube), and with the lower vessel into which the fractions are to be drawn, will be made with perforated rubber stoppers; but, if desired, they can of course be made with ground glass joints.

In detail, the apparatus consists of a cylindrical receiving chamber, A, graduated in cc. and with a funnel stem through which the distillate collected in A may be removed at will by opening the plain cock F. On one side of this receiving chamber, near the top, is the opening B, for the end of the condenser. From the top of the receiving chamber A, the tube C passes to the pump P and to the outer jacket E of the funnel stem. On this tube C, there is a plain cock at H, and a 3-way cock with offset ports at D. By turning this 3-way cock 90°, connection is established by means of a perforation in the stem of the cock, between the

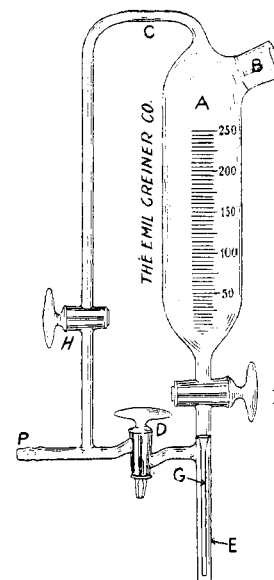

FIG. 1