



# Computer Aided Design in Knitting Manufacturing

# Main mechanisms of knitting machines

## Module 3

## 1. The yarn guiding and control assembly

Has the following functions:

- Guiding the yarn from the bobbin to the yarn guide
- Stopping the machine in case of yarn depletion, breakage, or the appearance of knots
- Controlling the yarn tension
- Preventing yarn slackening with tensioning devices

# The yarn guiding and control assembly

The optimal path depends on the type of yarn and the structure of the knit.

*Feeding path 1:* The yarns are not passed through the antennae at the ends of the needle beds - Seldom used yarns (separation yarn, elastic yarn)

*Feeding path 2:* Usual structures - Frequently used yarns, common structures

*Feeding path 3:* The yarn is passed through the friction-based feeding mechanism - Yarns that are harder to process, with a high friction coefficient

*Feeding path 4:* The yarn is passed through the STIXX mechanism – for knits with high uniformity of structural parameters

# The yarn guiding and control assembly

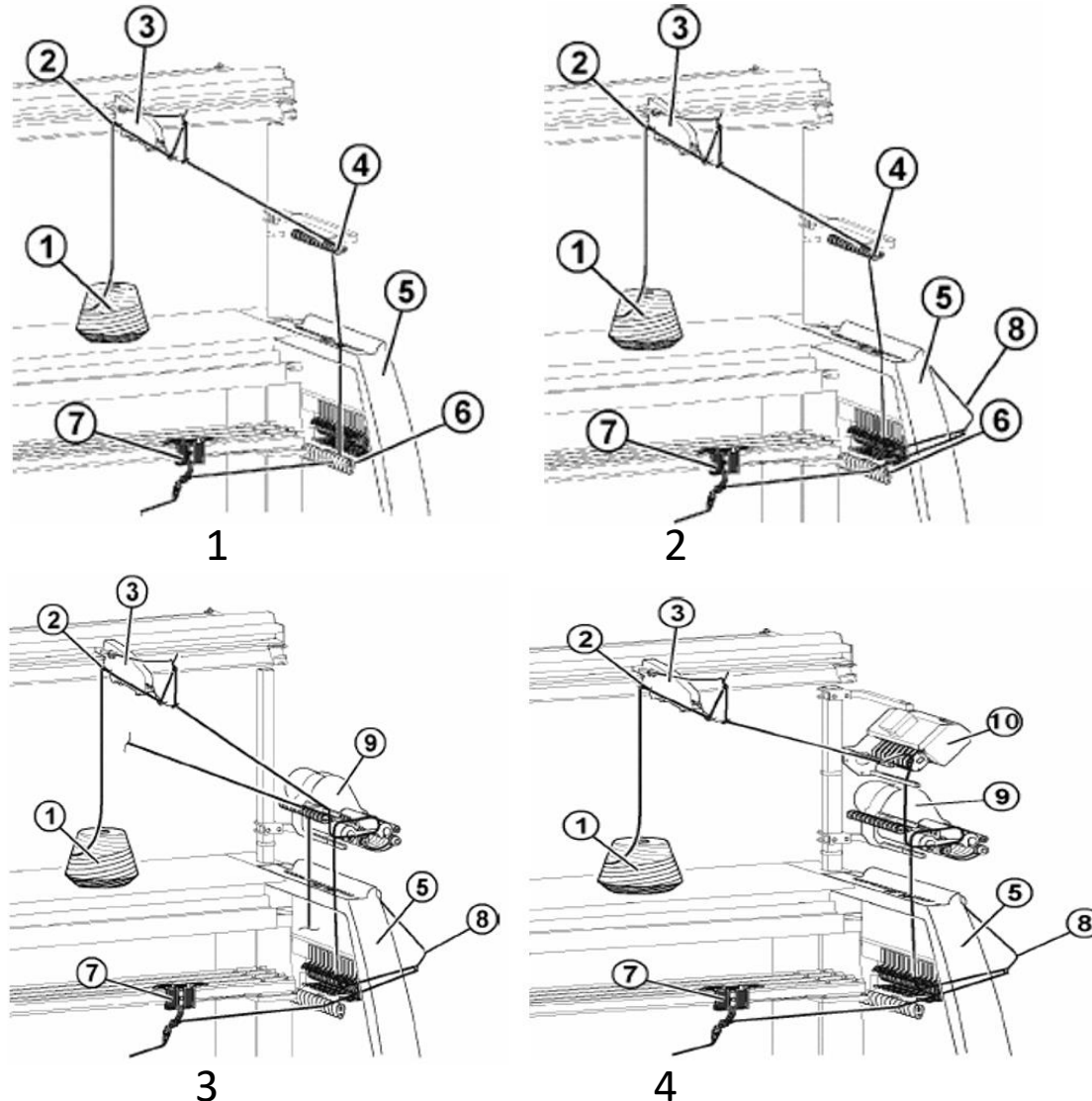

1. Bobbin
2. Guiding eye
3. Yarn control unit
4. Guide roller
5. Protective cover
6. Guide roller
7. Yarn guide
8. Lateral tensioning device
9. Friction-based feeding mechanism
10. STIXX device

# The yarns control unity

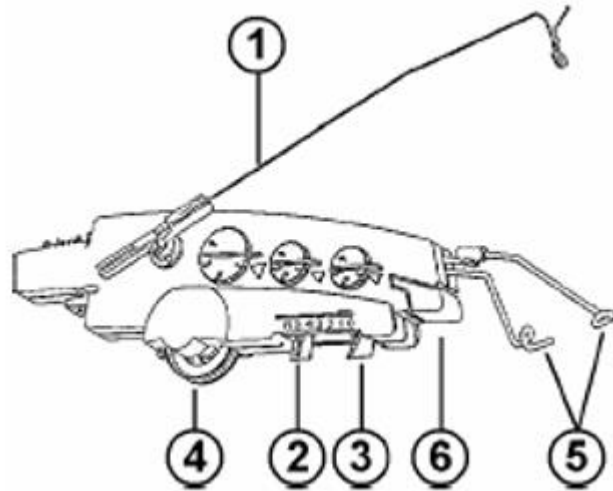

1. Elastic antenna
2. Large knot detector
3. Small knot detector
4. Tensioning device with discs
5. Guiding eyes
6. Signal lamp

- The elastic antenna (1) controls the yarn tension during feeding and prevents slackening. In the event of yarn breakage or depletion, the elastic antenna stops the knitting machine. The fault is indicated by the tubular lamp (6) on the control unit, the signal lamp, and on the knitting machine's monitor.
- If large knots appear in the yarn, the knot detector stops the knitting machine. The fault is indicated by the tubular lamp (6) on the control unit, the signal lamp, and on the knitting machine's monitor. If small knots appear in the yarn, the knitting machine continues to operate for a programmed number of rows at a reduced speed.
- The guiding eyes (5) guide the yarn and prevent the threads from touching or crossing.
- The tensioning device with discs (4) controls the yarn tension.

# Lateral Tensioning Device (Elastic Recovery Antennas)

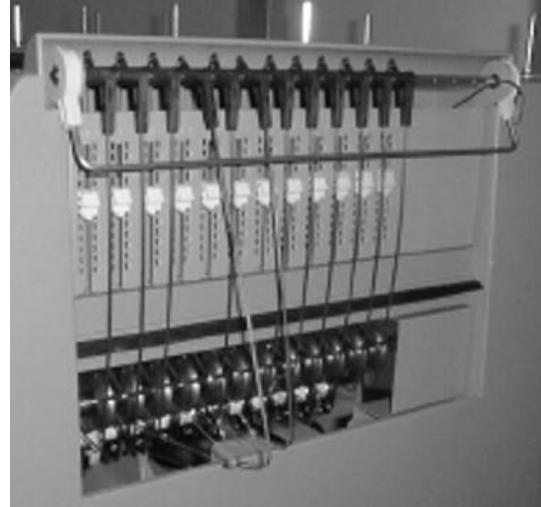

- to recover excess yarn when the carriage changes its direction of movement
- in the event of yarn breakage or depletion, this device stops the knitting machine more quickly and can store a longer yarn length than the elastic antenna on the yarn control unit

# The Friction-Based Feeding Mechanism

- improves the feeding conditions by reducing yarn tension during supply.
- it pulls the yarn from the bobbin and delivers it via friction at low tension toward the yarn guide

## The Yarn Clamping and Cutting Device

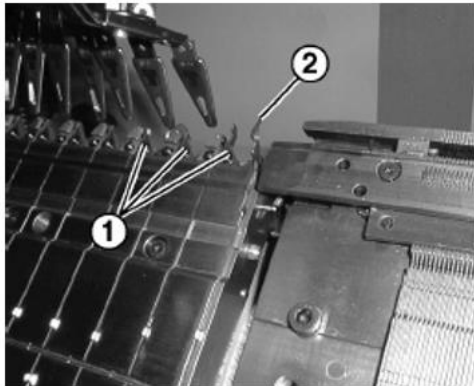

1. Clamping clips
  2. Hook
- mounted on the front needle bed of the knitting machine. Each side contains eight clamping clips (1). These clips are actuated by the carriage with the locks.
  - holds the yarns of the yarn guides that are not in use during the knitting process. The hook (2) pulls the yarn downward, after which the yarn is clamped and cut
  - when the yarn guide is used again, the carriage opens the clamping clip after a programmed number of rows have been knitted, and the yarn end is released

## 2. The Loop Forming Mechanism

- includes various technical components (latch needle, transfer elements, sinkers, selectors, etc.)
- Latch needle, with lateral transfer blade, with a leaf spring in the joint of the latch, with a working heel
- Oscillating needle guide, with a retractable middle working heel and a slightly bent shaft
- Selector sinker, with a retractable upper heel, a lower heel, and a locking step
- Single-type oscillating selector, with an upper working heel, a lower heel, and a pressing tail
- Leaf spring embedded in the oscillating selector; in its relaxed state, the spring brings the lower heel of the selector to the surface of the needle bed
- Oscillating knock-over sinker; at the top of the channel wall, the movable sinker is associated with a fixed knock-over tooth

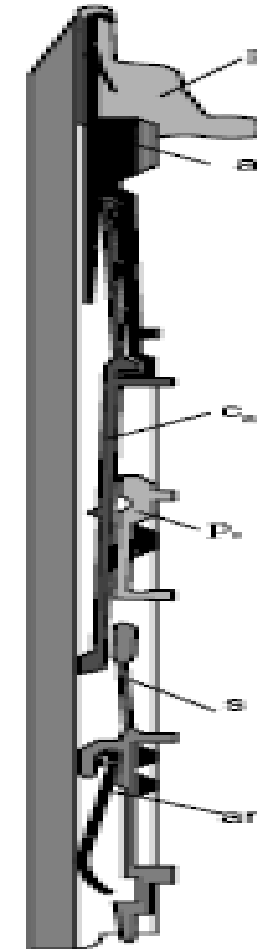

# The Loop Forming Mechanism

Integrated cam systems with fixed and oscillating cams for loop formation, transfer, pressing, guiding, and selector control.

1. Fixed raising-closing cams (+), S - In or S - I
2. Fixed transfer-receiving cams (+), included in cams 1, S - In-t
3. Fixed safety cams (+), I - In
4. Fixed pressing cams (+); these cams are used for stitch transfer
5. Dual-purpose cams: inner lowering edges are used for loop formation, outer raising edges are used for stitch transfer, In - B or S - I+ $\Delta$
6. Fixed guiding cams (+); act on the heel of the knitting needle and initiate the lowering motion from position I+ $\Delta$
7. Oscillating tongue; acts on the heel of the knitting needle and lowers the needle along the path I+ $\Delta$  - I
8. Fixed edge cams (+); at the base of the cams, in the inner corners, there are delayed lowering edges without loop formation
9. Fixed driving cams (+), S - S
10. Oscillating pressing cams; act on the lateral sides of the cam system, near cams 1 and 5, and are used for receiving the stitches
11. Oscillating pressing cams; act at the center of the cam system and are used for loop formation
- 12, 13. Fixed guiding cam assemblies (+) that act on the lower heels of the selector sinkers; guidance can be made at 3 levels depending on selection: base position 0 and drawing positions 1 and 2
14. Fixed pressing cams (+); act on the upper heels of the selector sinkers
15. Selection cancellation cams at the edges of the system (+)
16. Blocks with 2 selection posts (BS1 and BS2)
17. Raising cam for drawing position 2 (+)
18. Raising cam for drawing position 1 (+)
- 19, 20. Central selection cancellation cams (+)
21. Selector activation cams; edge 21a acts on selection post BS1, and edge 21b acts on selection post BS2
22. Pressing cams for the selector tails; their action brings the selector ends closer to the permanent magnet of selection block 16

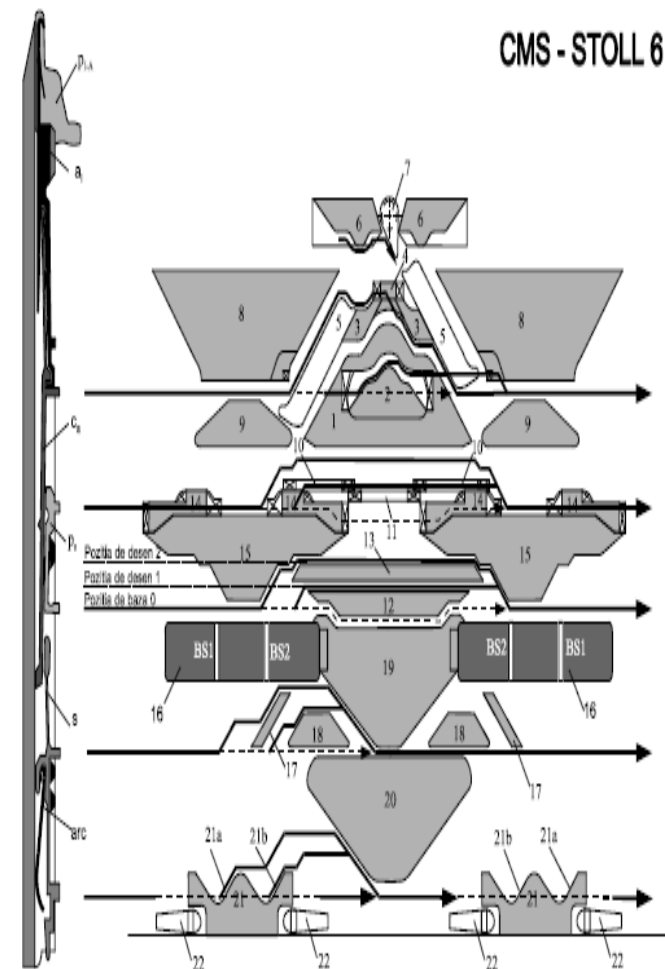

Co-funded by  
the European Union

# The Loop Forming Mechanism

- Needles selection
- Knitting and transfer path analysis

Traiectoria	Impuls de selectare		Poziția de desen	Poziții de came		
	BS1	BS2		10, 11	5	
S - S	Nu	Nu	0	↑	↗	↘
S - In -B	Nu	Da	1	↑	↗	↘
S - I - B	Da	Nu	2	↑	↗	↘
S - In-t - S	Nu	Da	1	↓	↙	↖
S - I+Δ -B	Da	Nu	2	↓	↙	↖
S - S	Nu	Nu	0	↑	↗	↘
S - In -B	Nu	Da	1			
S - I - B	Da	Nu	2			
S - S	Nu	Nu	0	↓	↙	↖
S - In-t - S	Nu	Da	1			
S - I+Δ -B	Da	Nu	2			

# The Loop Forming Mechanism

- The closing-throw sinker have the role of locking the loops on the needles at the moment the needles are raised.

1. Cam carriage
2. Brush shoulder
3. Plate cam

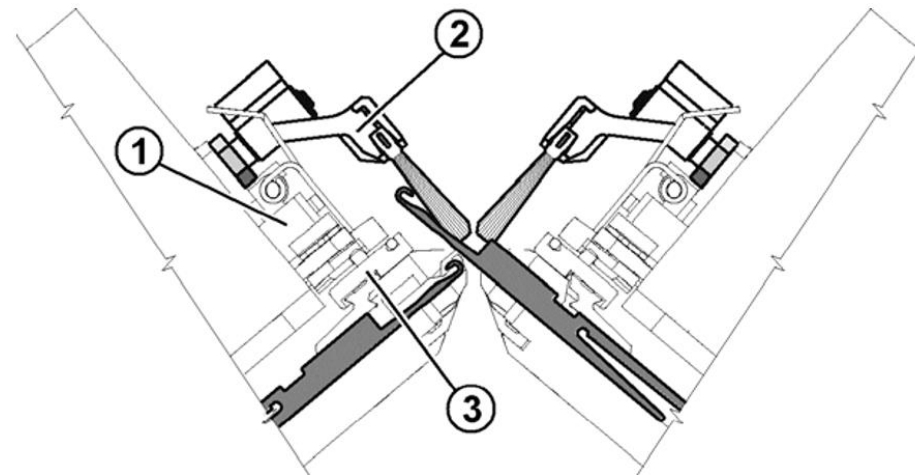

# The Loop Forming Mechanism

- Stepper motor for adjusting the loop depth
- Protective devices
  - Sensor for detecting needle position
  - Resistance stop
  - Shock stop

## 3. The Lateral movement mechanism of the back needle bed

- The front needle bed is fixed. The back needle bed can be moved laterally relative to the front needle bed.

# The Lateral movement mechanism of the back needle bed

## Lateral movement amplitude [needles]

E 20	80
E 18 ( E 9.2 )	72
E 16	64
E 14 ( E 7.2 )	56
E 12 ( E 6.2 )	48
E 10 ( E 5.2 )	40
E 8	32
E 7 ( E 3, 5.2 )	28
E 5 ( E 2, 5.2 )	20
E 4	16
E 3.5	14
E 3	12



- The additional displacement mechanism pretensions the loops before the transfer so that they become wider. Then, the needle bed is brought into the programmed position for the transfer.
- To protect the yarn and ensure safe transfer, the back needle bed with needles can be moved laterally at a reduced speed. Under these conditions, the cam carriage remains stationary at the reversal point until the needle bed has been moved.

# 4. The Fabric Take-Down Mechanism

- Main take-down mechanism with sectional cylinder and individual pressure rollers
- Auxiliary take-down mechanism with knurled cylinders
- Automatically operated start comb

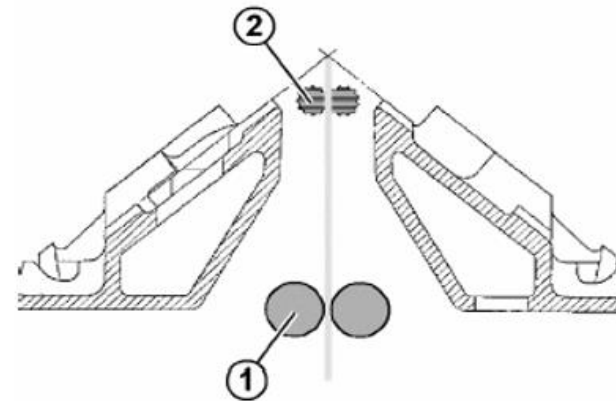
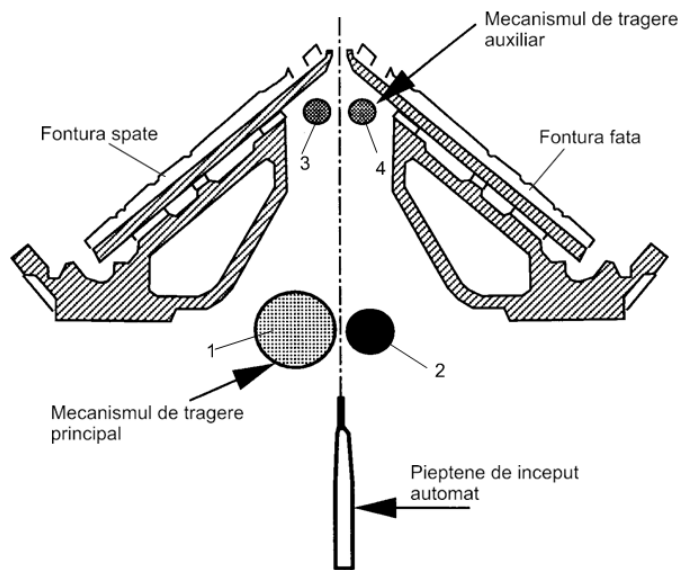
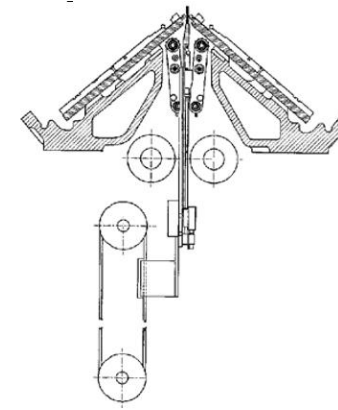

- Main Switch



- Work Bar

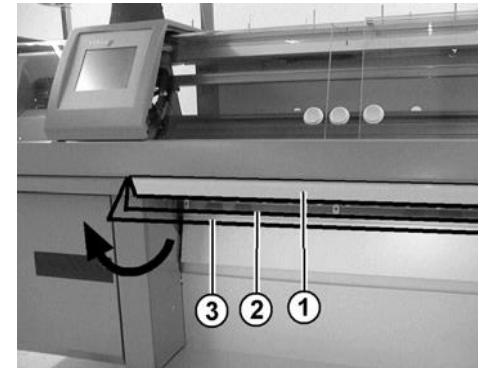

- Signal Lamp

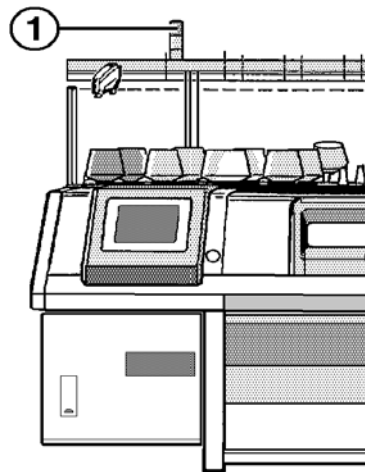

- Data Input and Machine Command Unit



# Display and Operating Elements

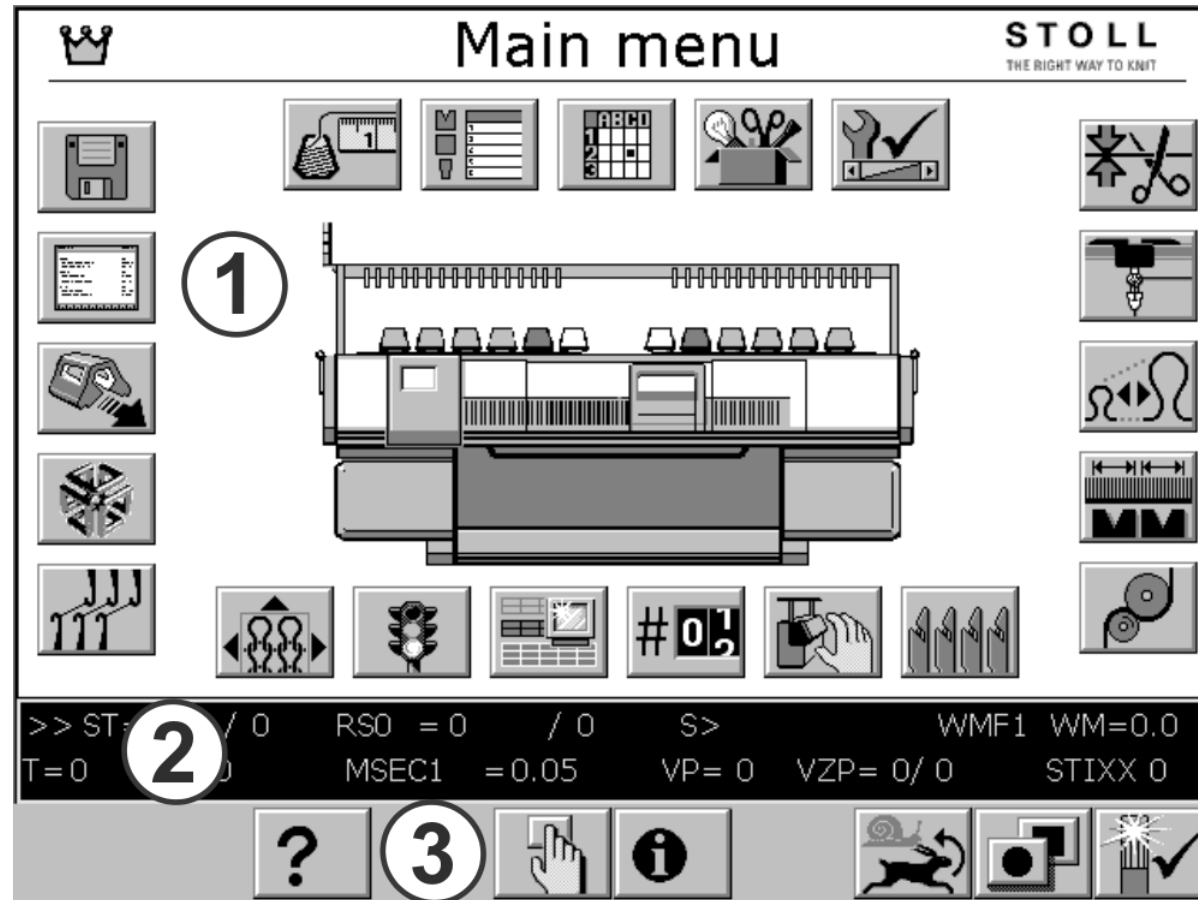

- Adjusting Knitting Speed

Carriage speed		STOLL THE RIGHT WAY TO KNT	
Normal MSEC	0.05	<input type="text" value="0.05"/>	
Intarsia MSEC1	0.05	<input type="text"/>	MSECNPJ 0.05
Knot selectable MSECk	0.00	<input type="text"/>	for 1 <input type="text"/> Row(s)
MSEC0 (Empty row)	0.00	<input type="text"/>	MSEC5 0.05 <input type="text"/>
MSEC1 (Transfer)	0.00	<input type="text"/>	MSEC6 0.05 <input type="text"/>
MSEC2	0.05	<input type="text"/>	MSEC7 0.05 <input type="text"/>
MSEC3	0.05	<input type="text"/>	MSEC8 0.05 <input type="text"/>
MSEC4	0.05	<input type="text"/>	MSEC9 0.05 <input type="text"/>

- Input Fields

*Normal MSEC*: Regular yarn guide speed (0.05–1.20 m/s)

*Intarsia MSEC1*: Intarsia yarn guide speed (0.05–1.00 m/s)

*Knot selectable MSECk*: Speed after detecting small knots (0.05–1.20 m/s)

*for row(s)*: Number of rows at reduced speed after knots (1–12)

*MSEC0*: Idle movement speed (0.05–1.4 m/s)

*MSEC1–MSEC9*: Speeds callable from program (0.05–1.4 m/s)

- Adjusting Stitch Length

STOLL		THE RIGHT WAY TO KNIT					
NP1:	11.0 <input type="text" value="11.0"/>	NP11:	12.5 <input type="text"/>	NP21:	12.5 <input type="text"/>	NPK:	0.0 <input type="text"/>
NP2:	11.5 <input type="text"/>	NP12:	12.5 <input type="text"/>	NP22:	12.5 <input type="text"/>	NPR:<<	0.0 - 0.0
NP3:	12.0 <input type="text"/>	NP13:	12.5 <input type="text"/>	NP23:	12.5 <input type="text"/>		<input type="text"/> <input type="text"/>
NP4:	12.5 <input type="text"/>	NP14:	12.5 <input type="text"/>	NP24:	12.5 <input type="text"/>	NPR:>>	0.0 - 0.0
NP5:	13.0 <input type="text"/>	NP15:	12.5 <input type="text"/>	NP25:	12.5 <input type="text"/>		<input type="text"/> <input type="text"/>
NP6:	12.5 <input type="text"/>	NP16:	12.5 <input type="text"/>	NP26:	12.5 <input type="text"/>		<input type="text"/> <input type="text"/>
NP7:	12.5 <input type="text"/>	NP17:	12.5 <input type="text"/>	NP27:	12.5 <input type="text"/>		<input type="text"/> <input type="text"/>
NP8:	12.5 <input type="text"/>	NP18:	12.5 <input type="text"/>	NP28:	12.5 <input type="text"/>		<input type="text"/> <input type="text"/>
NP9:	12.5 <input type="text"/>	NP19:	12.5 <input type="text"/>	NP29:	12.5 <input type="text"/>		<input type="text"/> <input type="text"/>
NP10:	12.5 <input type="text"/>	NP20:	12.5 <input type="text"/>	NP30:	12.5 <input type="text"/>		<input type="text"/> <input type="text"/>
						Stitch tension	
						Length [mm]	
						NP1in mm:	2.00

- Input Fields

*NP#*: Cam position number

*NPK*: Cam position correction for all locations

*Stitch tension*: Depth in units

*Length (mm)*: Loop length in mm



- Adjusting the Yarn Control Unit

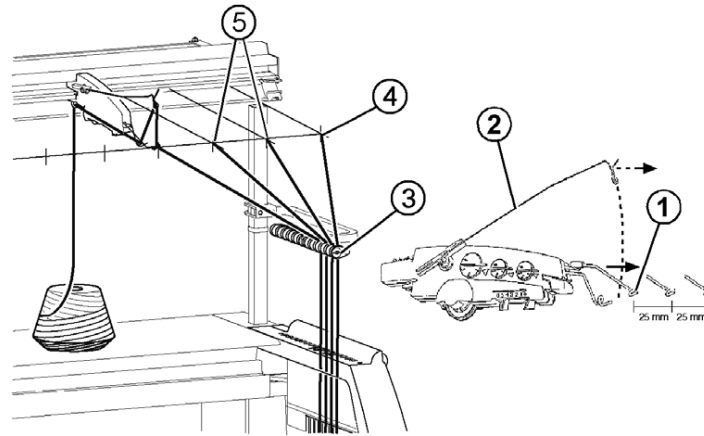

Fan-shaped Yarn Arrangement

- Adjusting Side Elastic Antennas

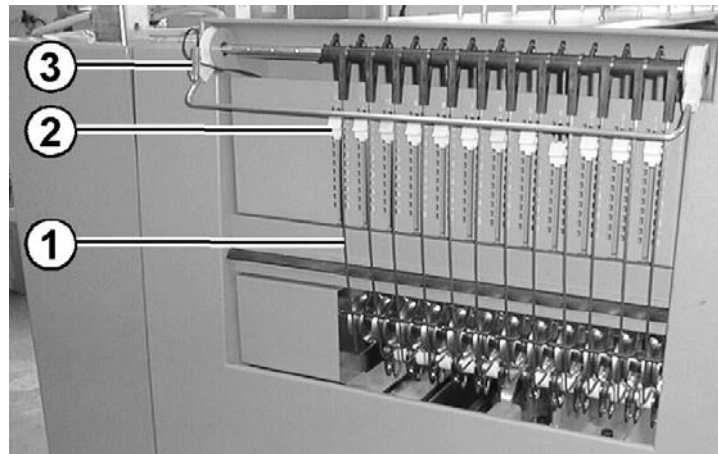

- Setting Knitting Zones





SEN	from needle	to needle	Selection (manual)	Selection (Program)
1	1	1	Off On	Off On
2	0	0	Off On	Off On
3	0	0	Off On	Off On
4	0	0	Off On	Off On

- Up to 4 zones (SEN) can be defined in SINTRAL program. Compact machines work with one SEN zone. If not set in software, configure via “Knitting zone” window.
- Assign needles to each zone
- Set ON/OFF switches for each zone under “Selection (manual)”

- Adjusting the Take-Down Mechanism

 **Fab. take-down** **STOLL**  
THE RIGHT WAY TO KNIT

Actual WM 0.0 Change in line: 0 Actual WMF: 1

Main take-down	0.0 <input type="text" value="0.0"/>	Auxiliary take-down	1 <input type="text" value="1"/>
Take-down value (WM)	0 <input type="text" value="0"/>	Aux. take-down Speed (W+=)	0 <input type="text" value="0"/>
Take-down impulse (WMI)	0 <input type="text" value="0"/>	Contact pressure (W+P)	0 <input type="text" value="0"/>
Proc. correction (WM%)	0 <input type="text" value="0"/>		
Main take-down	 Clo. Op.	Auxiliary take-down	 Op. Clo.
Main take-down	 Backw. Forw.	Auxiliary take-down	 Backw. Forw.
Fabric sensor	 Off On		

- Setting Piece Count and Counters

#01		Cycle counters & counters				STOLL					
		THE RIGHT WAY TO KNIT									
Piece number		0	0	Still to be knitted.	0						
RS1:	0		RS6:	0		RS11:	0		RS16:	0	
RS2:	0		RS7:	0		RS12:	0		RS17:	0	
RS3:	0		RS8:	0		RS13:	0		RS18:	0	
RS4:	0		RS9:	0		RS14:	0		RS19:	0	
RS5:	0		RS10:	0		RS15:	0		MT:	0	
#L:	0		#R:	0		#LM:	0		#RM:	0	
#51:	0		#52:	0		#53:	0		#54:	0	

- *Piece counter*: Number of items to knit; decreases after each piece
- *RS1*: Border rows
- *RS17*: Start comb activation
- *RS18*: Elastic yarn insertion for border
- *RS2–RS25*: Program zone repetitions

# THANK YOU FOR YOUR ATTENTION!

## *Project coordinator:*

- **Mines Saint-Etienne:** <https://www.mines-stetienne.fr/>
- **Pr. Xavier BOUCHER:** [boucher@mines-stetienne.fr](mailto:boucher@mines-stetienne.fr)

## *Our contacts:*

- **Website:** <https://www.codemo-project.eu/>
- **E-mail:** [info@codemo-project.eu](mailto:info@codemo-project.eu)

## *Our socials:*

- **Twitter:** <https://twitter.com/omilab>
- **LinkedIn:** <https://www.linkedin.com/showcase/codemo-project/>
- **Facebook:** <https://www.facebook.com/openmodelslaboratory/>



UNIVERSITATEA  
LUCIAN BLAGA  
— DIN SIBIU —

Dr. Eng. BRAD Raluca  
[raluca.brad@ulbsibiu.ro](mailto:raluca.brad@ulbsibiu.ro)



Co-funded by  
the European Union