

T H E

# AMERICAN JOURNAL OF SCIENCE

[ F O U R T H S E R I E S . ]

ART. XLII.—*An Experimental Investigation into the Flow of Rocks, by Frank D. Adams, assisted by Ernest G. Coker. First Paper—The Flow of Marble. (With Plates II-IV.)*

CONTENTS.

*Introduction.*

Factors in Rock Flow.

Results obtained in former investigation.

Aims of present study.

*Methods Employed.*

*The Flow of Marble.*

1. Deformation of the dry rock at ordinary temperatures.
  - (a) At comparatively low pressures. Structure of the deformed marble.
  - (b) At very high pressures. Structure of the deformed marble.
  - (c) Strength of the marble after deformation.
  - (d) Influence of rest and of heat on the strength of the deformed marble.
2. Deformation of the dry rock when at temperatures of 300° C. and 400° C.
  - (a) Strength of the marble after deformation.
3. Deformation of the rock at temperature of 300° C. in the presence of water.
  - (a) Strength of the marble after deformation.
4. Specific gravity of the rock after deformation.

*Conclusions.*

*Introduction.*

THAT the rocks of the earth's crust, under the stresses to which they are subjected, have been bent and twisted in the most complicated manner is a fact which was realized by the earlier geologists, and it needs but a glance at an accurate geological section through any highly contorted district of the earth's crust to see that during the folding of the rocks there

has often been a marked transfer or "flow" of material from one place to another within the fold.

While, however, these facts are undisputed, the precise nature of this folding and flowing has been a subject concerning which there has been much discussion and a wide divergence of opinion.

Some authorities—among whom Heim,\* whose work in the Alps must command the admiration of all, may be mentioned—have held that while in the upper portions of the earth's crust, rocks when submitted to pressure will break, giving rise to faults and overthrusts—the same rocks in the deeper portions of the earth's crust are unable to break up in this way, owing to the great weight of the superincumbent strata. The lines of fracture they hold in this case become smaller and greatly increase in number, the various minerals constituting the rock thus breaking down into grains, which, however, move around and past one another, the adjacent grains always remaining within the sphere of mutual cohesion. The structure of the rock thus becomes cataclastic; but the rock mass, while acting as a plastic body and flowing in the direction of least resistance, maintains its coherence while altering its shape.

Now according to Spring,† the property known as regelation is really due to a power which fragments of bodies have of uniting if brought within the range of the molecular forces, a property which, although possessed in a marked manner by ice, is also, as he has experimentally demonstrated, exhibited by many other bodies and would probably be displayed by all if the required conditions could be attained. The "flow of rocks" would, therefore, according to Heim's view, be a manifestation of regelation on an enormous scale.

Other writers on this subject have maintained that rocks are absolutely destitute of plasticity in any proper sense of the term. Pfaff‡ has even held that in the depths of the earth great pressure will tend rather to prevent molecular movement and thus keep the rocks rigid. Those holding such views attribute the deformation of rocks either to crushing with subsequent recementation of the fragments by mineral matter deposited from percolating waters as the movements proceed or after they are completed,§ or to a continuous process of solution and redeposition of the minerals which

\* *Der Mechanismus der Gebirgsbildung*, p. 31, 1878; see also Van Hise, C. R., *Metamorphism of Rocks and Rock Flowage*, Bull. Geol. Soc. of America, vol. ix, 1898.

† *Recherches sur la propriété que possèdent les corps de se souder sous l'action de la pression*; *Revue Universelle des Mines*, 1880.

‡ *Der Mechanismus der Gebirgsbildung*, pp. 19–21.

§ Stapff, *Zur Mechanik der Schichtenfaltungen*, *Neues Jahrbuch für Mineralogie*, 1879, p. 792; Reyer, *Theoretische Geologie*, p. 443.

make up the rock. The percolating waters, it is held, tend to dissolve material at those points where the pressure is greatest, and to redeposit it where the pressure is wholly or partially relieved; the movements thus being accompanied by a more or less complete recrystallization of the whole rock. Moisture would thus be a necessary factor in all rock folding or contortion, and recrystallization the essential feature of the phenomenon. The deformation of a body of dry rock would be impossible.

An experimental study\* of the subject was undertaken some years since, the rock selected being Carrara marble. The investigation showed that in the case of this rock plastic deformation could be brought about by the action of pressure alone, that heat made the rock more plastic, and that under the conditions of the experiments, the presence of water exerted little or no influence in this respect.

By this it is not meant to imply that when rocks are folded in the earth's crust solution and redistribution do not play a very important rôle. These processes undoubtedly are at work and are widespread in their action. It is quite possible that they are the most important agencies in the folding and flow of rocks.

The experimental study showed, however, that the presence of water was not an essential factor in the development of flow, in the case of marble at least, and that under the experimental conditions, that is to say with the deformation carried out in days, weeks, or at most in a few months, instead of being extended over long periods measured by years or centuries, the deformation of the marble took place quite independent of solution.

It showed furthermore that the structures displayed by highly contorted marbles in many parts of the earth's crust are identical with those produced under the experimental conditions and that they have been developed by the same agencies.

As the subject seemed to be one worthy of further study, the work was continued under a grant from the Carnegie Institution of Washington, and as the investigation went forward it was found to be necessary to follow out several separate lines of research.

The amount of cubic compression which rocks undergo when submitted to pressure from every side was first investigated, all rocks of course being subjected to such compression before deformation.†

\* Adams, F. D., and Nicolson, J. T.—An Experimental Investigation into the Flow of Marble; *Phil. Trans. Royal Soc., London, Series A*, vol. cxv, pp. 363–401.

† Adams, Frank D., and Coker, Ernest G.—An Investigation into the Elastic Constants of Rocks, more especially with reference to Cubic Compressibility; Publication of the Carnegie Institution of Washington, No. 46 (Résumé in this Journal, Aug. 1906.)

A further study was then made of the "flow of marble" under widely varied conditions of pressure, temperature and time; after which the investigation was extended to a number of fine-grained and more or less impure limestones; to crystalline dolomites; and then to a series of typical plutonic intrusives—diabase, essexite and granite.

A series of comparative experiments were then made for the purpose of accurately measuring the loads required for the deformation of standard columns of these and other rocks under precisely identical conditions of differential pressure and extremely slow movement.

In the present paper it is proposed to outline the methods employed in these investigations and to present the results obtained by the further study of the "Flow of Marble"; and in subsequent papers to set forth the results obtained in the case of some of the other and more resistant rocks. The results of the investigation as a whole when completed will appear, in extended form and fully illustrated, as a Publication of the Carnegie Institution of Washington.

#### *Methods Employed.*

In seeking to ascertain experimentally the action of differential pressure on rocks with a view to reproducing more or less accurately the conditions of pressure which obtain in the deeper parts of the earth's crust, it is manifestly quite useless to attempt to reproduce these conditions by simply submitting the rocks to compression in a testing machine, as is done in testing the strength of materials. There is certainly differential pressure in this case, but it is merely the ordinary atmospheric pressure on the sides of the test-piece, while the tremendous pressure of the testing machine acts in the vertical direction. It is necessary to increase the lateral pressure and make it in some degree at least approach the measure of that exerted in a vertical direction if the pressure conditions of the deeper parts of the earth's crust are to be reproduced. The material must be held in and supported laterally, so that it will not readily break or fracture as the vertical pressure is brought to bear upon it until at least the required conditions of differential pressure have been secured.

In the deformation of rocks within the earth's crust the pressure element which corresponds to this lateral resistance is furnished by the great weight of overlying strata forming the upper portion of the earth's crust, while the direct pressure exerted by the testing machine represents the tangential thrust which folds them.

To secure this lateral resistance, two methods have been proposed. The first is that suggested many years ago by

Kick, in which a stout copper case is prepared within which the specimen is placed, the intervening space being filled by alum, sulphur or some other more or less plastic material, poured in when in a fused condition and which solidifies on cooling. (Fig. 1.) The whole is then submitted to the action of a powerful press and squeezed down. Upon the completion of the experiment the embedding material is removed by heat or solution and the deformed specimen obtained. This method is easily carried out, but it has a number of defects. Thus, the experiments can be carried out only at the ordinary tem-

FIG. 1.

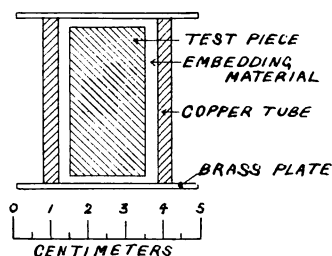

perature of the laboratory; the lateral resistance offered is not as great as is required in the case of the harder rocks, and it is furthermore impossible to determine the pressure to which the specimen has been subjected, seeing that the load has been divided between the box, the embedding material and the specimen itself.

A series of experiments on the deformation of various minerals and rocks were, however, carried out by this method, the results of which are detailed in another paper.\*

The second method is that employed by Adams and Nicolson in their investigations on the Flow of Marble. In this a column of the rock is very accurately turned or ground in a lathe and fitted into a heavy tube of steel which has been bored out with equal accuracy to receive it. Pistons of hardened chromium-tungsten steel are then inserted into the ends of the tube, the pressure being transmitted through them to the column enclosed in the steel. By this method a much greater lateral resistance can be secured, which makes it possible to carry out the deformation under much higher

\* Adams, F. D.—An Experimental Investigation into the action of Differential Pressure on certain minerals and rocks employing the process suggested by Professor Kick; *Journal of Geol.*, 1910.

pressures. This resistance also may be varied as desired by altering the thickness of the walls of the enclosing tube, and the pressure under which the rock is being deformed can be accurately measured, seeing that the whole vertical pressure is brought to bear directly upon the specimen. The deformation may, furthermore, be carried on at temperatures approaching even to incipient redness and, if required, in the presence of water or steam.

The material employed in the construction of the enclosing tubes in our earlier experiments was wrought iron or a mild carbon steel, but in all later work a steel containing 4.10 to 5.18 per cent of nickel was employed. This steel has a considerably higher elastic limit than ordinary carbon steel, and our thanks are due to the Bethlehem Steel Company for several consignments of this steel which have been used in the investigation. For the construction of the pistons the chromium tungsten "Novo" steel was employed. This steel when heated to whiteness and plunged into fish oil develops extraordinary strength, a specimen having the dimensions of one of the pistons—namely .815 inch in diameter and 1.56 inch long—when tested in compression having sustained a load of 215,000 lbs., equivalent to 411,880 pounds per square inch, with practically no alteration of shape. The pistons of this steel may, furthermore, be used under the great pressures employed at temperatures as high as 600° C.

In order that the conditions of differential pressure may be satisfactorily developed, it is necessary to make that portion of the enclosing nickel-steel tube immediately surrounding the central portion of the rock column thinner than it is elsewhere, while leaving the portions of the tube about the ends of the column thicker. This concentrates the flow or deformation of the rock, giving a symmetrical bulge developed within the column and between its extreme ends, and prevents the enclosing tube from opening up under the pressure and permitting the rock to force itself up between the pistons and the ends of the steel tube. As the result of a long series of experiments, too numerous to detail here, it was found that a tube of the dimensions shown in the accompanying drawing (fig. 2) was the most suitable, the thickness of the wall immediately around the central part of the specimen being increased from 25 millimeters to a centimeter according to the amount of lateral pressure or resistance which it is desired to develop, all the other dimensions of the tube remaining the same. The pistons at either end were inserted into heavy steel castings by which the load was transmitted from the press.

The rock columns upon which the experiments were carried out were in most cases about 2<sup>cm</sup> (.814 inch) in diameter and

about 4<sup>cm</sup> (1.56 inch) long. In the earlier experiments the rock was first ground into rough columns 6<sup>cm</sup> long and 2.5<sup>cm</sup> in diameter on a rubbing bed. Subsequently a small diamond drill was installed having a hollow bit, which proved an excellent device for readily securing a rough column of any rock which it was desired to use for experimental work. This was then cut into lengths and turned into columns of the required size in a lathe. The final very accurate shaping of the columns was given to them by grinding with an emery or corundum wheel while in the lathe. In this way the little columns were turned to the desired shape with extreme accuracy. They were not as a general rule made exactly cylindrical in shape, but in order to secure a very accurate fit were usually made slightly conical with a taper of 1/1000 of an inch in their length.

In the same way the steel tube was first turned in a lathe in the usual manner, the inner surface was then ground to secure greater accuracy of shape, and the tube was finally finished by the employment of a reamer. In this way a taper identical with that given to the column was secured, the column, however, being slightly larger than that portion of the tube which was to enclose it. The tube was then heated by placing a red hot iron ring about it and when thus expanded the rock was gently shoved into it to the required position, and the tube being allowed to cool, a mechanically perfect fit of the tube to the column was secured.

When it is desired to carry out the deformation at temperatures above that of the laboratory and up to 600° C. or more,

FIG. 2.

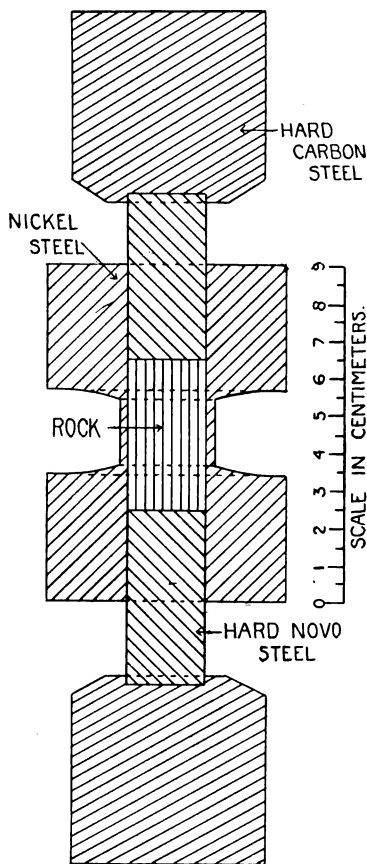

the rock with its tube is enclosed in a small stove of special construction heated by a gas blast, the air being supplied by a Reichhelm blower driven by a 2 h.p. electric motor.

In experimental work formerly carried out on the Flow of Marble at temperatures up to 400° C., a small cast-iron stove was used. As in these later experiments much higher temperatures—up to 1000° C.—have been employed, it was found that in many cases it was extremely difficult to remove the steel tube

FIG. 3.

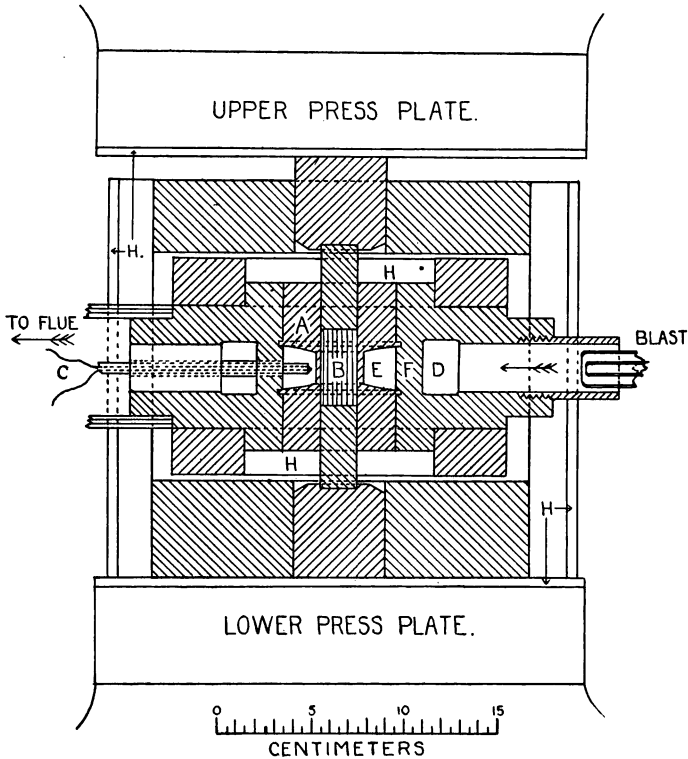

enclosing the rock from the stove at the conclusion of the experiment, the two having become partially welded together. A stove of cast steel has, therefore, been substituted, made in two parts which are firmly held together by heavy steel collars during the experiment, which collars can be removed at the conclusion of the experiment, allowing the stove to fall apart and access to the enclosed tube to be thus easily obtained. This form of stove has proved very satisfactory. A section of it is shown in fig. 3.



The casting is so arranged that hot gases circulate in an annular channel (D) within it, and outside of the wrought iron cylinder (A), the rock (B) being thus kept at a high temperature while the pressure is applied. The casting is as massive as possible and a very uniform temperature is thus maintained during the whole time of the experiment. The temperature of the enclosed rock is ascertained by means of a platinum—platinum rhodium couple (C), provided with properly calibrated resistance boxes, etc. This lies in the air space (E) by the side of the tube which incloses the specimen. The hot gases are excluded from this space by the wall (F). The whole is well lagged with asbestos, asbestos millboards (H) being also inserted between the bases of the pistons and the plates of the press.

When it is desired to deform the rock at high pressures and temperatures in the presence of water, a modified form of the stove was adopted. The apparatus employed for the purpose has been described in the former paper, to which reference has been made.

Upon the conclusion of the experiment the deformed tube with its enclosed rock was placed in a lathe and the steel tube was carefully turned off until a mere film of metal remained. This was carefully filed through along one line and the enclosed rock was thus obtained intact.

In experiments where very accurate measurement of the pressures employed was required, the large 100-ton Wickstead testing machine set up in the testing laboratory in the Engineering Building of McGill University was employed. In other experiments a series of three hydraulic presses, provided with suitable intensifiers and necessary accessory appliances, were employed. These were calibrated from time to time by direct comparison with the Emery testing machine in the testing laboratory, and the accuracy of their reading thus maintained. The most powerful of these presses, which was the one usually employed, has a capacity of 120 tons.

#### *The Flow of Marble.*

In a former paper, as has been mentioned, it has been shown that under conditions of differential pressure marble flows as a plastic body. In the present contribution the results of further experimental work, carried out with the view of obtaining a more complete and thorough knowledge of the behavior of marble under varying conditions of differential pressure, are presented.

1. *Deformation of the dry rock at ordinary temperatures.*(a) *Deformation at comparatively low pressures. Structure of the deformed marble.*

The pressures employed ranged from 120,000 to 130,000 lbs. to the square inch. A series of experiments was first made in which the marble was enclosed in wrought iron tubes. The walls of these tubes immediately surrounding the marble had a thickness varying from  $1/8$  to  $1/4$  of an inch, and the load was slowly applied until deformation, indicated by the bulging of the tube, had commenced. So soon as movement ceased the load was increased slightly and the movement was thus resumed, and in this manner the deformation was carried on at a rate which was kept as nearly as possible constant.

The experiments were arranged so that in some cases the deformation went forward rapidly and in other cases very slowly, the time occupied being from ten minutes to sixty-four days.

In later experiments, as has been mentioned, the wrought-iron tubes were replaced by tubes of steel. These latter had the advantage of offering a higher resistance and also of being more easily prepared and more uniform in strength than those of wrought iron. This latter quality was of especial importance in cases where experiments were carried on in series under identical conditions for purposes of comparison. Plate IV shows such a tube with the enclosed marble column, cut open after deformation.

The deformed marble was uniform and compact and seemed to break with equal ease in all directions. It differed somewhat in appearance from the original rock in possessing a dead white color, the glistening cleavage surfaces of the calcite being no longer visible, and the contrast being well brought out when the deformed column is split or cut through vertically, owing to the fact that a portion of the original marble often remained unaltered and unaffected by the pressure. This, when present, had the form of two cones of obtuse angle whose bases are the original ends of the column resting against the faces of the steel pistons, while the apices extend into the deformed marble and point toward one another. These cones, or rather parabolas of rotation, are also developed, as is well known, where cubes of rock, cement or cast-iron are crushed in a testing machine in the ordinary manner. In the present experiments they sometimes constitute a considerable proportion of the whole mass; in other cases they are absent or but faintly indicated; but there is always in immediate contact with the ends of the steel pistons at least a thin cake of marble possessing the character of the ordinary rock.

Thin sections of the deformed column passing vertically through the unaltered cone and deformed portion of the rock were readily made and when examined under the microscope clearly showed the nature of the movement which had taken place. Under the microscope the deformed portion of the rock can be distinguished at once by a turbid appearance differing in a marked manner from the clear, transparent mosaic of the unaltered cone. In that portion of the rock which has suffered deformation the calcite individuals have been squeezed against one another in such a manner that a distinct flattening of the grains has resulted. The individuals are not only flattened, but in some cases distinctly twisted, these movements being effected by the development in the calcite, first of marked strain shadows, and then, where the movement is more intense, by the appearance in each calcite grain of a series of fine parallel lines or very narrow bands giving to it a fibrous appearance, which bands become more numerous as the distortion of the grain becomes more pronounced, the calcite as these bands increase in number displaying a progressive decrease in transparency. When highly magnified, these lines are seen to be due to an extremely minute polysynthetic twinning. The chalky aspect of the deformed rock on the surface of fracture is chiefly due to the destruction by this repeated twinning of the continuity of the even cleavage surfaces of the calcite individuals, thus making the reflecting surfaces much smaller.

By this twinning the calcite individuals are enabled under pressure to alter their shape somewhat, while the flattening of the grains is evidently due to movements along the gliding planes of the crystals.

In the paper by Adams and Nicolson describing the results formerly obtained in the deformation of marble at ordinary temperatures, it was stated that a microscopic examination of the deformed rock revealed the presence of an "anastomosing meshwork of curved and branching lines" of minutely granulated calcite running through the rock, these being lines of cataclastic structure similar to those obtained when marble is deformed by Kick's process. In our more recent experiments, however, this cataclastic structure is seldom found and in many cases is entirely absent. This is probably due to the fact that in this latter work the grinding and fitting of the columns to the tubes has been carried out with the utmost accuracy, while in the former experiments mechanical work was less perfect and the column probably did not in all cases fit its tube perfectly. It is probable that the little lines along which cataclastic structure is developed may have been largely due to a slight shearing of the column before perfect adjustment of the tube had been effected by the pressure to which it was subjected.

A faint but distinct cataclastic structure is, however, found in some cases even when the support offered to the marble by its steel tube is perfect, and along planes of greatest movement the calcite individuals can in some cases be seen to have been apparently slightly torn.

*(b) Deformation at very high pressures—Structure of the deformed marble.*

In order to ascertain whether under a greater load the cataclastic structure would entirely disappear, another series of experiments were carried out employing much higher pressures and at the same time carrying the deformation as far as possible. This was secured by increasing the thickness of the wall of the tube which enclosed the marble. A tube of wrought iron built up in the same manner as a gun barrel and having a wall thickness of  $\cdot 5$  inch ( $12\cdot 7^{\text{mm}}$ ) for a length of  $\cdot 625$  of an inch ( $15\cdot 875^{\text{mm}}$ ) along the central portion of the tube about the enclosed marble column was employed. Steel pistons were then inserted and the pressure applied in the usual way. The tube commenced to bulge when the pressure reached 35,000 lbs. (15,870 kilos.), and the maximum load applied to the marble was 154,000 lbs. (169,750 kilos.), that is to say, a pressure of 296,725 lbs. per square inch (20,875 kilos. per square cent.), the deformation being carried on slowly and occupying forty-one hours. This is equivalent to a depth of 46 miles below the surface of the earth. A photograph of the tube upon the completion of the experiment is shown in Plate II (*a*). Under this tremendous pressure the upper steel piston failed, four radial cracks developing on its face in contact with the marble, thus dividing the piston face into four nearly equal quadrants. These cracks extended up into the piston for approximately half an inch ( $12\cdot 7^{\text{mm}}$ ), the largest of them being one one-hundredth of an inch ( $\cdot 254^{\text{mm}}$ ) in width at its widest part, and the marble was forced up into these very narrow cracks. Notwithstanding the great thickness of the ends of the tube, moreover, a small amount of the marble under this enormous pressure passed up between the piston and the inner surface of the tube, in a form which while coherent was sufficiently soft to yield to the finger nail with ease. The marble was removed from the bulged tube by turning off the latter in a lathe. That portion of the rock which had not been forced up around the pistons, constituting of course almost the entire mass, was obtained in the form of a slaty cake  $\cdot 682$  inch ( $17\cdot 3^{\text{mm}}$ ) in height and  $1\cdot 135$  inch ( $28\cdot 81^{\text{mm}}$ ) wide at its widest part, and in form somewhat barrel-shaped. This is shown in Plate II *b* with a column of its original dimensions placed beside it for purposes of comparison. On the

surface of this cake no reticulating (Luder's) lines such as those observed when marble is deformed in Kick's experiment are seen.

A series of thin sections of the deformed marble was then prepared. When examined under the microscope these sections show that the marble has had developed in it a most striking and beautiful foliated structure due to the arrangement of individuals of calcite, each of which has been flattened out so that in a section passing vertically through the deformed column it presents the appearance of a ribbon drawn to a point at either end and from eight to ten times as long as it is wide. These elongated calcite individuals are perfectly moulded upon one another, coming together along sharp and gently sinuous lines. A microphotograph of this deformed rock, together with one of the original marble, is shown in Plate III. While many of them possess a very fine polysynthetic twinning, causing them to maintain a generally uniform illumination as they are revolved between crossed nicols, the movement has evidently been chiefly of the nature of a translation or slipping on gliding planes without the development of pronounced twinning, so that the elasticity axes of the various individuals lie nearly parallel to one another, and the whole rock section thus becomes light and dark four times during a revolution between crossed nicols, the periods of extinction being reached when the longer axes of the crystals (i. e., the foliation of the rock) coincide with the vibration planes of the nicols. In sections parallel to the foliation, the flattened individuals are seen to have a rudely polygonal form, often presenting somewhat rhombic outlines, some showing strain shadows which in many cases can be seen to result from a polysynthetic twinning of almost ultra-microscopic minuteness. This is of especial interest, as it is precisely this movement of individual lamellæ of measurable width over one another that gives rise to the phenomenon of the "flow" of metals. Calcite, however, is apparently much more prone to twin during this deformation than metals are, although the greater difficulty of recognizing twinning in metals—the latter being opaque—may have led to the frequency of this phenomenon in their case being underestimated.

The marble shows no trace of granulation and the movement set up in it is an example of perfect plastic flow.

The rock has a distinct foliated structure and the plane of foliation is transverse to the vertical axis of the deformed column, that is to say, at right angles to the direction of pressure in that part of the column between the piston faces, but immediately about the sides of the highly deformed and flattened column the foliation bends up until it runs approximately par-

allel to the walls, thus following the direction of movement which would be developed in any plastic mass when flowing away from between the advancing pistons in a confined space such as that afforded by the deformation of the enclosing tube. A microphotograph of this deformed marble is shown in Plate III *b*.

Another experiment similar to that just described was carried out with a column of marble of the same size enclosed in a nickel-steel tube with a wall thickness at the thinnest part of  $\cdot 19$  inch ( $\cdot 5^{\text{cm}}$ ). This required a pressure of 221,160 lbs. per square inch, which increased the diameter of the column to 36.7 per cent. In this the same structure was developed in the marble as in the case of the experiment just described, but the deformation being smaller, the foliation developed in the rock was not quite so marked.

(c) *Strength of the marble after deformation at ordinary temperatures.*

A series of columns of Carrara marble of the size regularly employed, namely  $1\cdot 575$  inch ( $4^{\text{cm}}$ ) long and about  $\cdot 814$  inch ( $2^{\text{cm}}$ ) in diameter, with a slight taper, were prepared and were put into a series of tubes made of a mild carbon steel. The walls of the tube were  $\cdot 592$  inch ( $1\cdot 5^{\text{cm}}$ ) thick, except in the central portion of the marble, where for a length of  $\cdot 688$  inch ( $1\cdot 75^{\text{cm}}$ ) the wall was thinned away to  $\cdot 13$  inch ( $\cdot 33^{\text{cm}}$ ) so as to localize the bulging here. The pistons were then put into the tubes in the usual way and the marble deformed so as to give the column a barrel-shaped form having a diametral enlargement of as nearly as possible  $\cdot 2$  inch ( $\cdot 508^{\text{cm}}$ ), or 24.5 per cent. This deformation was produced in one minute, a 100 ton Buckton testing machine being employed. The maximum load required to complete the deformation at this rate of speed averaged about 56,000 lbs. (25,390 kilos.). This very rapid deformation severely tested the steel tubes, a number of them splitting before the required deformation was secured and being therefore rejected. Eighteen such experiments were made, eleven of which were successful, the tube remaining unruptured. The steel tubes were turned off as soon as possible after the conclusion of the experiment and the bulged columns of marble thus set free. Of these the first two having been carefully measured were at once tested in compression to ascertain their strength. In each case the load at which the first splitting of the marble took place was noted and then the load under which the column finally broke down.

The next three columns were allowed to stand for 100 days (or 2400 hours) and were then tested in the same manner. Four others, after having been freed from the enclosing steel

Time of deformation	Number of experiment	Maximum bulge of steel tube (inches)	Maximum bulge of marble (inches)	Time after deformation when tested (hours)	Special treatment	Load at which specimen first split (lbs.)	Load at which specimen broke down (lbs.)	Average load at which specimens broke down (lbs.)	Percentage of original strength	Pounds per square inch
1 minute	108	.228	.242	24	none	3200	4150	4175	60.6	7910
"	115	.174	.211	4	none	3300	4200			
"	111	.196	about .2	2400	Rest for 100 days	3700	4750	4517	65.7	8558
"	112	.172	" "	2400		3600	4160			
"	113	.174	" "	2400		4300	4640			
"	116	.176	.193	21	Heated to 100° C	2400	3470	3822	55.5	7241
"	117	.214	.225	21	for 20 hours	3100	3920			
"	163	.159	.189	77		2550	4000			
"	121	.176	.205	31			3900			
"	119	.175	.213	77	Heated to 350° C for 20 hours	2650	3900	4150	60.3	7863
"	164	.163	.201	77		3520	4400			
30 days	337		.182	2 years	Left in collar		7150	5830	84.7	11,050
"	388		.183	"	"		4920			
"	389		.189	"	"		5420			
Original Marble	177b		.21			Break down suddenly	6780	6886		13,046
"	178		.21				6180			
"	179		.21				7475			
"	180		.24				6140			
"	181		.24				7290			
"	182		.21				7660			
"	183		.21				6460			
"	184		.22				7100			

tube, were heated in a water bath for 24 hours and then tested. The last two, after being freed from the steel tube, were maintained at a temperature of 350° C. for 20 hours and then tested as before.

Eight columns of the original marble, cut to the same barrel-shaped form and having the same average dimensions as those resulting from the one minute squeezes just described, were then prepared, and these also were tested in compression to ascertain their strength. It was found that these, instead of first splitting and then breaking down as in the case of the columns of deformed rock, showed no signs of preliminary rupture, but gave way suddenly and completely.

The results obtained, together with certain others to be referred to later, are given in the table on page 479.

It will be seen that when the marble is deformed in the manner described, the deformation being accomplished in one minute and tested so soon as the enclosing tube can be removed, it retains 60·6 per cent of its original strength.

In order to ascertain whether the deformed marble would be stronger if the deformation were carried out at a higher pressure, a column of the Carrara marble having the same dimensions as those above described was deformed in a heavy tube of nickel steel having a wall thickness of ·197 inch ( $\cdot 5^{\text{cm}}$ ) at the thinnest part. The deformation was carried out a little more slowly than in the case of the experiments above described, occupying 100 minutes, and the load required to effect the deformation was 115,000 lbs. Upon the completion of the experiment the deformed column, having been freed from its enclosing tube, was tested in compression and was compared with a column of the original marble cut to the same dimensions. The deformed column measured 1·07 inch ( $2\cdot 72^{\text{cm}}$ ) in diameter, which represents a diametral enlargement of 31·4 per cent. The loads required to crush the two specimens respectively were as follows:

Original marble.....	6525 lbs.	(2954 kilos.)
Deformed marble .....	5470 "	(2479 " )

The deformed marble thus retains 83·8 per cent of its original strength. The experiment was then repeated with three other columns and almost identical results obtained.

It will thus be seen that the increased pressure (accompanied by a somewhat slower rate of deformation) led to a greatly increased strength in the case of the deformed marble, the strength increasing from 60·6 per cent to 83·8 per cent.

In three other experiments an attempt was made to ascertain whether, if the marble were deformed under a still higher pressure, a still further increase in strength might be secured.



The thickness of the tube walls was accordingly increased to 1<sup>cm</sup>, that is to say, the thickness was doubled. It was found, however, that with a wall of this thickness it was impossible to confine the bulging of the marble to the thinner portion of the tube and thus secure a symmetrical barrel-shaped mass of deformed rock. The pressure required for this deformation was 387,000 lbs. to the square inch (273,000 kilos. per square cm.), and was so great that when subjected to it the marble forced its way up between the pistons and the walls of the tube, and the thin, wedge-shaped ridges so produced broke away and crumbled to powder as the steel tube was being turned off in a lathe.

Attempts were then made, by increasing the length of the marble column and altering the dimensions of the enclosing tube, to prevent the rock forcing its way up between the pistons and the thicker ends of the tube. These attempts, however, were unsuccessful, and it was evident from them that the result could only be accomplished by greatly increasing the thickness of that portion of the walls which enclosed the pistons, which would in its turn necessitate the employment of a much higher pressure to deform the rock, and this would result in the destruction of the pistons themselves. In the case of these experiments under very high pressure, furthermore, it was found that the deformed marble could not be obtained as a solid mass, for so soon as the last thin remnant of the steel tube which was left by the lathe was filed through, the marble developed cracks running across the column at right angles to its vertical axis. In some cases the deformed limestone at once broke in two along one of these cracks. In other cases it was obtained in what was apparently a solid mass, but upon standing a few minutes little transverse cracks, running partially or completely across the specimen, made their appearance. This phenomenon is apparently due to the expansion of the mass upon its relief from the tremendous pressure consequent upon the removal of the enclosing tube and is not confined to marble deformed under very high pressures, but is met with, as will be mentioned, in the case of the various impure limestones and dolomites whose deformation will be described later.

It was, therefore, found to be impossible to test the strength of the marble when deformed at these highest pressures owing to the fact that these transverse cracks invariably developed, thus destroying the continuity of the rock.

*(d) Influence of rest and of heat on the strength of the deformed marble.*

It has long been known that iron which has been overstrained, that is to say strained beyond its elastic limit, pos-

sesses very different elastic properties from the same iron in its original condition. The iron so treated assumes a more plastic character and a bar thus stretched will on the application of small additional loads undergo a further elongation or creeping, producing a permanent set. It is a well-known fact moreover that iron when thus over-strained will, if allowed to rest for a sufficiently long time, revert to its former state of normal elasticity, and Muir\* has shown that this recovery is greatly hastened by raising the temperature of the bar even a few degrees, and if the temperature be raised to 100° C., the reversion to the state of normal elasticity is very rapid, being accomplished in a few minutes instead of requiring several days.

As has been shown, the movement set up in marble under the conditions of deformation secured in these experiments is essentially of the same character as that which takes place in iron or other metals when they are deformed, for while there is in marble, when deformed at ordinary temperatures and at comparatively low pressures, a certain amount of granulation, this is very subordinate to the movement of the calcite on its gliding planes or by twinning, as before described. It was therefore conjectured that if the marble was rapidly deformed, thus giving rise to a comparatively weak product, this deformed rock might, following the analogy of the metals, become stronger if allowed to rest for a certain time. If the analogy to metals holds, it might still further be expected that the application of heat would bring about a more rapid recovery of strength on the part of the deformed rock than mere rest alone.

The results of three experiments in which the strength of the deformed column was tested after a rest of 100 days, as well as the results of four other experiments in which the marble after deformation was heated to 100° C. for 20 hours, and two experiments in which the marble after deformation was heated to 350° C. for 20 hours, are given in the table on page 479. As will be seen from an examination of the figures, the marble became distinctly stronger as the result of a rest of 100 days, but the application of heat, whether it be 100° C. or 350° C., does not noticeably accelerate the recovery of strength as it does in the case of the iron. In fact, the figures seem to show that the heating of rock to 100° C. for 20 hours rather weakens it and that it recovers this loss at a higher temperature.

Another series of three experiments was then made in which columns of marble and steel tubes of the same dimensions were

\*On the Recovery of Iron from Over-strain, *Phil. Trans. Royal Soc.*, series A, vol. xciii, pp. 1-46.

employed, but in which the deformation was carried on very slowly, being extended over a period of 30 days, and in which the marble after deformation was allowed to remain in its enclosing steel tube for two years, after which time the steel tube was turned off in the usual way and the marble tested in compression to determine its strength. As will be seen by consulting the table on page 479, under these conditions of slow deformation and long, subsequent rest, the deformed marble is but little weaker than the original rock, its strength being on an average 84.7 per cent of that which it originally possessed, while one of the deformed columns in this series showed a strength greater than the average strength possessed by the columns of the original rock.

Another series of three experiments, the results of which were published in a former paper, show that slow deformation alone conduces to increase of strength. In these experiments the deformation was carried on in wrought iron tubes, and at the conclusion of the experiments the tubes, instead of being placed in a lathe and turned off from the enclosing marble, were sawn in two vertically and the half columns of marble thus obtained. These when tested in compression gave the following results :

	Original height	Original diameter	Greatest diameter after deformation	Time of deformation	Crushing load for deformed marble, lbs. per square inch
Experiment A	1.594	1.000	1.407	64 days	5350
“ O	1.594	1.000	1.203	1½ hours	4000
“ P	1.505	1.000	1.388	10 minutes	2776

These values cannot be used for comparison with those of the former table owing to the fact that the shapes of the test pieces in the two series of experiments were quite different, but compared with one another we see clearly that slow deformation conduces greatly to the preservation of strength.

## 2. *Deformation of the dry marble when heated to temperatures of 300° C. and 400° C.*

In a former paper an account has been given of the deformation of the marble at these temperatures. Debray\* has shown that calcite when heated in closed vessels to a temperature of 350° C. suffers no decomposition, that at 440° C. the decomposition is “insensible,” while at 860° C. the disassociation of the molecule of carbonate of lime is marked. In the experiments carried out at 400° C., therefore, it would seem that the marble was deformed at the highest temperature which could be employed without danger of decomposition under atmospheric conditions of pressure.

\* Comptes Rendus, 1867, p. 603.

In these experiments, as in the case of those on page 479, the deformation was carried out at comparatively low pressures. The marble after deformation was hard and solid. Tested in compression it was found to be nearly as strong as the original marble. When sliced and examined under the microscope, the rock showed no trace of cataclastic structure, but the grains were seen to be distinctly flattened, giving to the rock a foliation which in some places was very pronounced. The calcite individuals showed the very narrow polysynthetic twinning producing the fibrous appearance before described. The twin lamellæ were in some cases twisted, the twisting being accompanied by strain shadows, which phenomenon, however, in this rock was neither very common nor very striking. The individual grains had to all appearance acted as plastic bodies. A very pronounced movement along gliding planes, coinciding in direction with the course of twin lamellæ, is undoubted. This movement, induced by comparatively low pressures at this elevated temperature, is identical in character with that produced by very high pressures at the ordinary temperatures. In both the movement is due to translation and twinning; breaking or cataclastic structure is absent.

The increased temperature evidently gives the calcite a freer movement on its planes of translation and twinning,—the rise in temperature increases its plasticity. In the case of ice crystals, as is well known, a rise in temperature develops similarly a greater ease of movement along the gliding planes.

### 3. *Deformation of the marble when heated to 300 C. in the presence of water.*

In the series of experiments formerly made, in addition to heat and pressure a third factor, viz., the presence of moisture, was introduced. A column of Carrara marble enclosed in its iron tube was slowly deformed while at a temperature of 300° C., but in the presence of water vapor under a pressure of 460 lbs. to the square inch (32.33 kilos. per square cm.). The apparatus used for the purpose of this deformation is described in the paper to which reference has already been made. This deformation was carried on very slowly, and at as uniform a rate as possible, the experiment extending over a period of 54 days or nearly two months. Tested in compression, the rock after deformation was slightly stronger than the original rock. Its structure was found to be identical in character with that seen in the case of the marble which had been deformed at 300° C. or 400° C. while dry. A distinct foliation was induced, some of the calcite individuals being three or even four times as long as they were wide. Some few of these flattened grains displayed strain shadows, but no twinning, while the grains in their immediate vicinity showed well-

defined twinning, giving rise to the fibrous appearance before described. In some cases a grain showed strain shadows at one end which passed over into a very narrow polysynthetic twinning at the other. The twin lamellæ in many cases are so narrow that even when magnified 1050 diameters they are not very clearly resolved. The individual lamellæ in several sets which were measured were found to have an average width of between .0005 and .0006 of a millimeter (.00001968 inch and .00002361 inch), and some were even narrower.

While the rock was deformed without loss of strength, the presence of water, so far as could be ascertained, did not influence the character of the deformation. It is just possible, however, that there may have been a deposition of infinitesimal amounts of calcium carbonate along very minute cracks or fissures, thus contributing to maintain the strength of the rock. No signs of such deposition, however, were visible.

#### 4. *Specific gravity of the marble after deformation.*

In order to determine whether as a result of deformation under high differential pressures, the specific gravity of the marble was in any way altered, the specific gravity of two specimens of deformed marble was taken as well as the specific gravity of two specimens of the original rock.

The first specimen of deformed marble, "A," had been deformed at ordinary temperatures in a tube of nickel steel 1<sup>cm</sup> thick, the experiment being carried out in 100 minutes, the pressure required to effect its deformation being 340,000 lbs. to the square inch. The second specimen of deformed marble, "B," had been deformed in a steel tube at a temperature of 400° C. in eight and a half hours at a pressure of 63,000 lbs. to the square inch. Both specimens of the deformed marble when placed in water showed at once that they were traversed by minute fissures, as a considerable amount of air was discharged in the form of minute bubbles. Specimen "A" was allowed to soak in the water until no further bubbles appeared. The rock when so treated was found to have a specific gravity of 2.65. The rock was then placed under water in an air pump. When the pump was worked additional air bubbles appeared, and the rock was allowed to remain under the vacuum until no further air was given off. After this treatment the rock was found to have the specific gravity stated in the accompanying table. In the case of specimen "B," the deformed rock was evidently more solid and compact, as less air was given off. This gives a partial explanation at least for its greater strength, it being evidently freer from minute cracks and fissures.

The following table shows the specific gravity obtained in the case of the various specimens:

Original marble—1st specimen.	Specific gravity
Specific gravity after the rock had been placed in water under a vacuum of 28½ inches of mercury for 24 hours .....	2·722
Original marble—2d specimen.	
After treatment in a similar manner .....	2·722
Average .....	<hr/> 2·722
Deformed marble—specimen “A,” 1st fragment.	
After having been placed in water under a vacuum of 28 inches of mercury until no further air was given off .....	2·712
Deformed marble—specimen “A,” 2d fragment.	
Treated in vacuo in the same manner for 24 hours, no further air bubbles being given off .....	2·717
Deformed marble—Specimen “B.”	
After having been placed under water in vacuo for 24 hours, until no further air was given off .....	2·713
Average .....	<hr/> 2·714
The comparison thus stands :	
Original marble .....	2·722
Marble after deformation .....	2·714
Difference .....	<hr/> ·008

This may be taken to mean that the marble remains unchanged in specific gravity by deformation, but that in the deformed marble some of the little cracks or crevices developed in the rock on relief of pressure still remain, into which the water can not penetrate, and which give rise to the slightly lower specific gravity of the deformed rock. In this connection it is to be noted that specimen “A” could not be tested for strength on account of the minute fissures by which it was traversed and which were developed upon the relief of pressure incident to the removal of the steel tube in which it was enclosed during deformation, while specimen “B,” which gave off comparatively few air bubbles, had the appearance of being much more solid.

In connection with these results it is interesting to note the results of the investigations carried out by Spring\* on the specific gravity of the sharply folded limestones in the Alps. In these he found that the specific gravity of the limestone on the concave side of a sharp fold, where the pressure of course is greatest, was slightly higher (·003 to ·023) than on the convex side of the same fold. This he at first interpreted as

\* Note sur la véritable origine de la différence des densités d’une couche de calcaire dans les parties concaves et les parties convexes d’un même pli ; Ann. Soc. Géol. de Belgique, xl, p. 4, 1883-4.

meaning that there had actually been a permanent condensation of the calcite by the greater pressure to which it had been subjected in folding. Further investigation, however, showed that the slightly lower specific gravity of the rock on the outer side of the fold was due to the presence in it of minute rifts or pores which were wanting in the rock on the more highly compressed inner side, the limestone itself really being of the same specific gravity throughout.

#### *Conclusions.*

1. Marble when deformed at ordinary temperatures will flow readily by distortion of the original calcite grains, accompanied, if the differential resistance be low, with the development of a certain amount of cataclastic structure.

2. The marble when deformed at ordinary temperatures will increase in strength if allowed to rest.

3. The marble, if deformed at ordinary temperatures, will be much stronger if the deformation be carried on slowly than if the deformation be rapid. There is every reason to believe that with the extreme slowness of deformation to which the rock is subjected in nature, and the long rest which it subsequently undergoes, the change in shape would be accomplished without any loss of strength.

4. If the deformation be carried on at a higher temperature, the calcite develops freer movement on its gliding planes, and the deformed rock will be relatively stronger than if deformed at the ordinary temperature.

5. Under the conditions to which the rock is subjected in these experiments,—although not under all conditions,—the presence of water has no recognizable influence on the character of the deformation.

6. The specific gravity of the rock is not increased by the pressure to which it is subjected during deformation.

McGill University, Montreal, Canada.

#### EXPLANATION OF PLATES.

##### PLATE II.

- a.* Wrought iron tube enclosing marble column after compression.  
*b.* Column of marble, before and after compression, under a load of 296,725 pounds per square inch (20,875 kilos. per square centimeter). The finer lines of the scale are 1 millimeter apart.

##### PLATE III.

- a.* Carrara marble, original. × 60.  
*b.* Carrara marble, caused to flow under pressure of 296,725 pounds per square inch. × 40.

##### PLATE IV.

Tube with its enclosed column of Carrara marble, cut open after deformation. The finer lines of the scale are 1 millimeter apart.

*a*

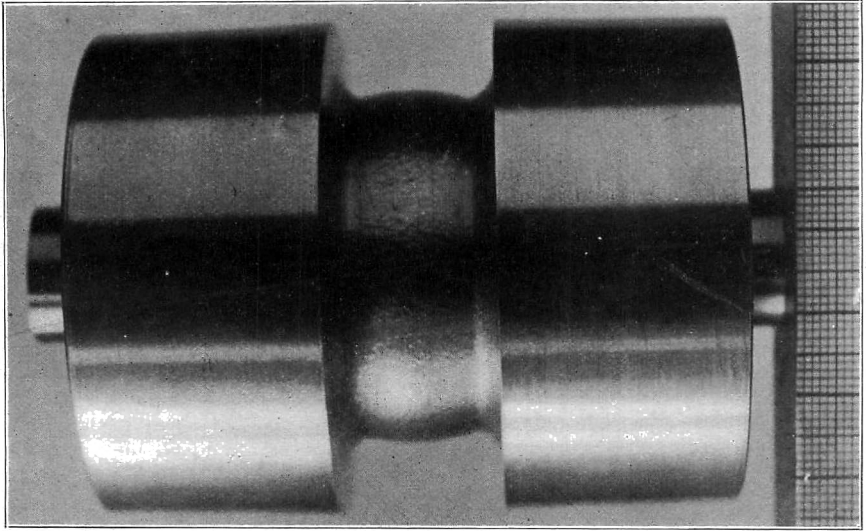

Wrought iron tube enclosing marble column after compression (see below).

*b*

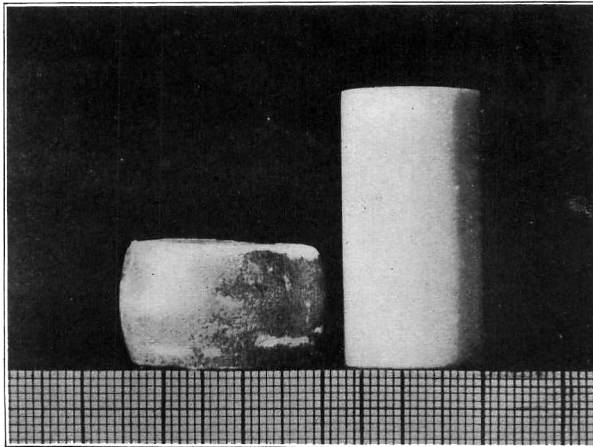

Column of marble before and after compression under a load of 296,725 pounds per square inch (20,875 kilos. per square cent.). The finer lines of the scale are one millimeter apart.



"

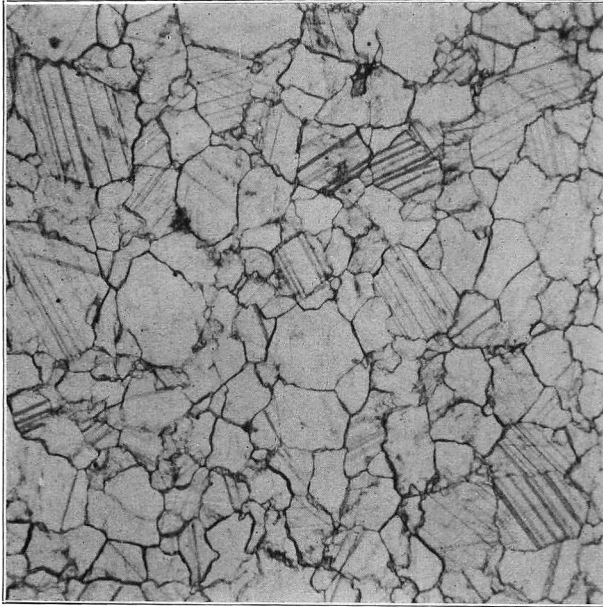

Carrara marble—original. ( $\times 60$  diam.)

*b*

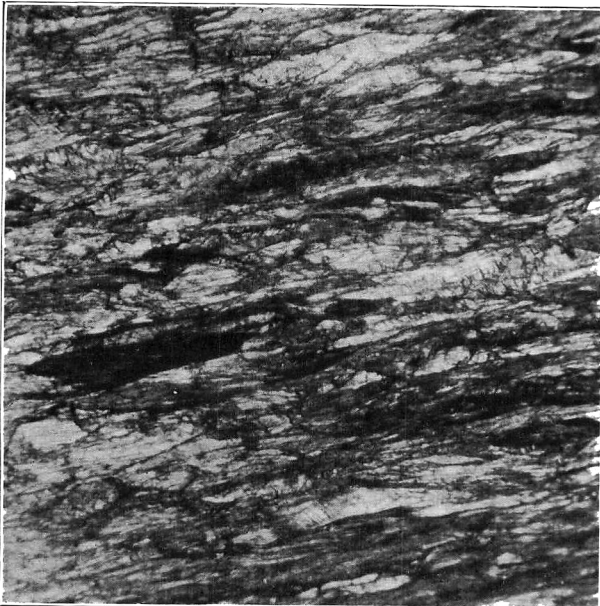

Carrara marble—caused to flow under pressure of 296,725 lbs. per square inch. ( $\times 40$  diam.)

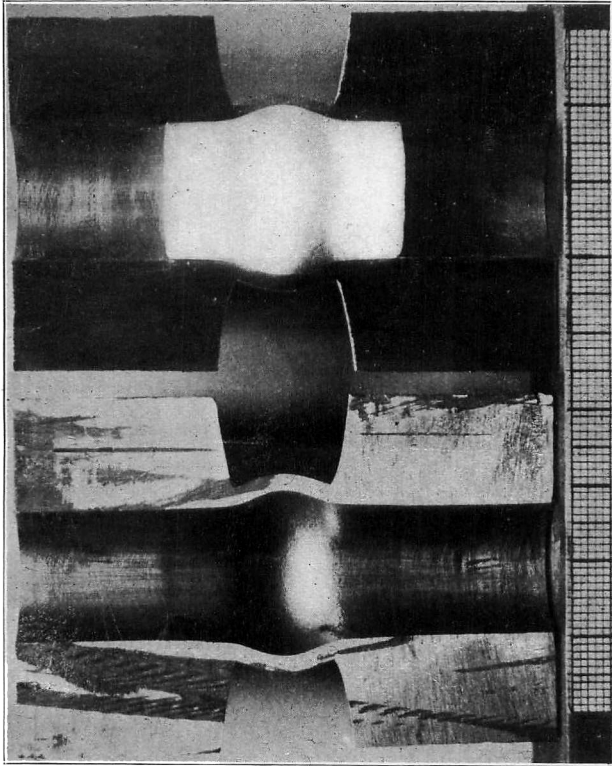

Tube with its enclosed column of Carrara marble—cut open after deformation. The finer lines in the scale are one millimeter apart.