

# A Low-pass Filter Method to Suppress the Voltage Variations Caused by Introducing Droop Control in DC Microgrids

Fulong Li  
Electrical, Electronic and Power  
Engineering  
Aston University  
Birmingham, B4 7ET, UK  
lif12@aston.ac.uk

Zhengyu Lin  
Electrical, Electronic and Power  
Engineering  
Aston University  
Birmingham, B4 7ET, UK  
z.lin@ieee.org

Wenping Cao  
Electrical, Electronic and Power  
Engineering  
Aston University  
Birmingham, B4 7ET, UK

Alian Chen  
School of Control Science and  
Engineering  
Shandong University  
Jinan, 250061, China

Jiande Wu  
College of Electrical Engineering  
Zhejiang University  
Hangzhou, 310027, China

**Abstract**—Small-scale DC microgrids have been popular in recent years due to their flexibility and wide applications. Droop control is one of the most widely applied control method in interface converters for a DC microgrid. However, methods to select proper droop coefficients or droop coefficient zones are rarely discussed in reported literatures. This paper analyzes the impact caused by large droop coefficients from loop-gain perspective, and proposes a low pass filter method to avoid the significant DC bus voltage variations, which is harmful to the power quality and voltage-based control strategies. Also, a droop coefficient zone is defined according to the current sharing and DC bus voltage variations. A simulation study has been implemented to validate the proposed droop coefficient zone and feasibility of the proposed low pass filter method.

**Keywords**—DC microgrids; droop coefficient; droop control; low pass filter.

## I. INTRODUCTION

DC microgrids have been popular in recent years for its advantages [1] over conventional AC grid, such as higher efficiency of energy utilization, less power transmission losses, no reactive power and harmonics. A typical DC microgrid is shown in Fig.1, which mainly includes DC power sources, energy storage systems and energy consumption. Applying droop control in two more paralleled interface converters is an efficient way regulate the power between them.

As one of the most widely applied control methods in DC microgrids, droop control was initially designed for solving circulating current between two or more paralleled converters. Meanwhile, it was found that adjusting droop coefficient can also regulate the current sharing between the converters. Therefore, droop coefficient (or virtual resistance) plays a key role in current sharing. Many papers have been published on the study of droop control including decreasing circulating current [2], current sharing [3-5] and adaptive power distribution [6-8]. However, methods to select proper droop coefficients and analyze the impact to the previous designed closed loop are rarely discussed, which is important to study

the dynamics of droop control and influence of system stability.

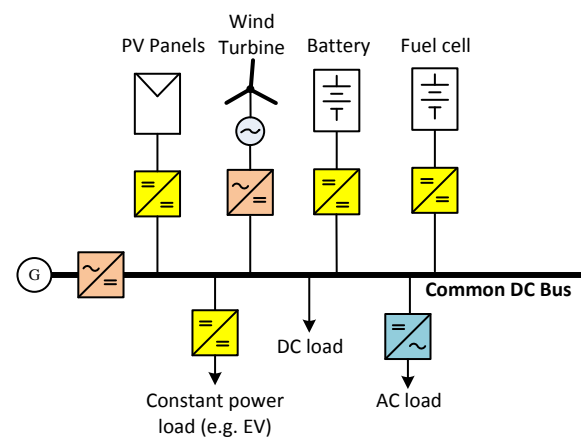

Fig.1. A typical DC microgrids configuration

It has been found that using larger droop coefficients can achieve more accurate current sharing. However, larger droop coefficients will cause the system stability issues [9]. The chosen of the maximum droop coefficient is normally according to the maximum load. However, increasing droop coefficient will increase the load current ripple before reaching its maximum allowed value, which could cause significant variations over the DC bus voltage. This is extremely harmful for these DC bus voltage based control strategies as aforementioned, such as DC bus signaling (DBS) [10-11] and power line communication [12]. Large DC bus voltage variations will increase the voltage window for DBS control methods, and require higher performance DC bus voltage detection circuit, otherwise, it might lead to misinterpretation. More effort and cost are thus required to implement these methods.

Another problem caused by using large droop coefficients is that the controller designed according to the steady state with zero droop coefficient might be no longer suitable for current working state. On the other hands, it involves shifting of quiescent operating point. This usually takes place under large load step changes. Therefore, the system will be divergent and no longer asymptotically stable for these

This work has received funding from the European Union's Horizon 2020 research and innovation programme under grant agreement No 734796, and U.K. the Royal Society International Exchanges scheme under Grant IE161121.

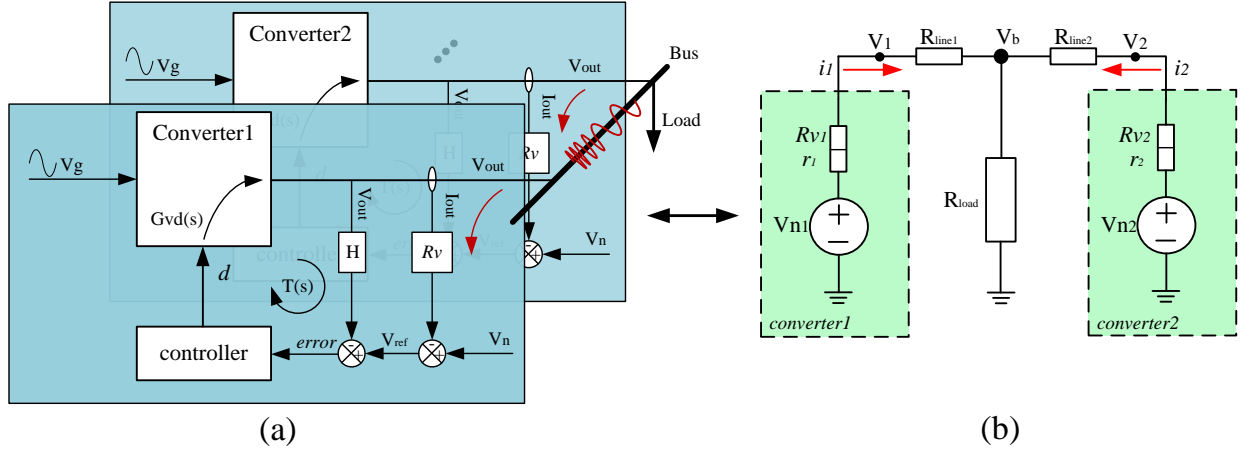

Fig. 2. (a) Internal control blocks of droop control of Boost converters; (b) simplified equivalent circuit of two-node distributed generation

converter with inherent Right-half-plane (RHP), such as boost converters. In real scenarios, the over-load operations are normally protected by external circuit breakers, which is out of the scope of this paper. Therefore, it will not be discussed in this paper regarding of exceeding the stable margin.

In this paper, the impact of introducing droop control on interface converters is analyzed. Droop control introduces voltage drop by multiplying virtual resistance with output current. The virtual resistance is used to vary the reference voltage according to the output current. Conventional close loop design requires sufficiently large closed loop gain to suppress the variation contained in the source and reference. Introducing droop coefficient will break the previous control loop, which makes the reference voltage involve the ripple contained in output current. So the closed control loop cannot suppress the low frequency ripple according to the control loop analysis. Adding dedicated low pass filter can filter the undesired low frequency ripple, therefore impact of introducing droop control on the output voltage variations can be reduced.

The rest of this paper is organized as follows: Section II gives the analysis of the issues caused by introducing droop control. The results show that large droop coefficients can lead to are theoretically predicted. Section III presents the simulation studies. Finally, the conclusions and future work are presented in Section IV.

## II. ANALYSIS OF LOOP VARIATIONS INTRODUCED BY DROOP CONTROL

### A. Configuration of system

Fig.2(a) shows the internal droop control blocks of boost converters, and Fig.2(b) shows a simplified equivalent circuit of two-node distributed generations. In Fig.2(a),  $T(s)$  is the conventional loop gain. When introducing droop control, this loop will be influenced by output current, which will be furtherly explained in following part. In Fig.2(b), two paralleled equivalent interface converters are used for illustrations.

The purpose of introducing virtual resistance in parallel voltage source based interface converters is to decrease the possible large circumvent current caused by terminal voltage

difference. According to the Fig.2(b), the following equations (1) and (2) can be attained:

$$V_b = V_{n1} - i_1(R_{v1} + R_{line1} + r_1) \quad (1)$$

$$V_b = V_{n2} - i_2(R_{v2} + R_{line2} + r_2) \quad (2)$$

where  $V_b$  is the common terminal voltage,  $V_{n1}$  is the converter 1 nominal voltage,  $i_1$  is the output current,  $R_{v1}$  is the droop coefficient,  $R_{line1}$  is the line resistance and  $r_1$  is the Thevenin equivalent resistance; similarly,  $V_2$  is the converter 2 nominal voltage,  $i_2$  is the output current,  $R_{v2}$  is the droop coefficient,  $R_{line2}$  is the line resistance and  $r_2$  is the Thevenin equivalent resistance.

The voltage drop is determined by three parameters:  $R_v$ ,  $R_{line}$  and  $r$ . In a small-scale DC microgrid, the  $R_{line}$  can be neglected, which means  $R_{line} \ll R_v$ . If  $R_v$  is also sufficiently larger than  $r$ , this means the  $R_v$  will dominate voltage drop. on the other hands, the larger of the  $R_v$  is, will the less impact be caused by  $R_{line}$  and  $r$ , so furtherly the more accurate current sharing is in the control loop. This explains why large droop coefficient can have accurate power sharing mentioned in introduction part.

### B. Loop-gain analysis by introducing droop control

As aforementioned, larger droop coefficient can make line resistance and equivalent internal resistant of DC source value less over total output resistant. However, using larger droop coefficient also has its disadvantages, such as increasing bus voltage variations that is harmful to bus voltage based control strategies and lead the phase margin unbearable for quiescent operating point shifting.

The reason lies that introducing droop control changes the control block of the original system. Equation (3) gives the general relationship from input to output according to the control blocks shown in Fig.2(a).

$$V_{out} = V_{ref} \frac{1}{H} \frac{T}{1+T} + V_g \frac{G_{vg}}{1+T} - I_{out} \frac{Z_{out}}{1+T} \quad (3)$$

where  $V_{ref}$  is the reference voltage,  $H$  is the output voltage feedback gain,  $T$  is the closed loop gain,  $V_g$  is the input voltage,  $G_{vg}$  is the line transfer function,  $i_{out}$  is the output current and  $Z_{out}$  is the output impedance.

After introducing droop control, it can be seen that this relationship will be modified by equation (4) and then equation (5) can be attained.

$$V_{ref} = V_n - I_{out}R_v \quad (4)$$

$$V_{out} = \underbrace{(V_n - I_{out}R_v)}_{V_{ref}} \frac{1}{H} \frac{T}{1+T} + V_g \frac{G_{vg}}{1+T} - I_{out} \frac{Z_{out}}{1+T} \quad (5)$$

From equation (5), the closed loop transfer function from  $V_{ref}$  to  $V_{out}$  is influenced by the introduced droop control. So denote

$$V_m = I_{out} \frac{R_v}{H} \frac{T}{1+T} \quad (6)$$

where  $V_m$  is the voltage drop.

Equation (6) shows that the voltage drop is affected by output current and droop coefficient. Large current (big load) leads to large voltage drop as well as the large variations contained or coupled in output current.

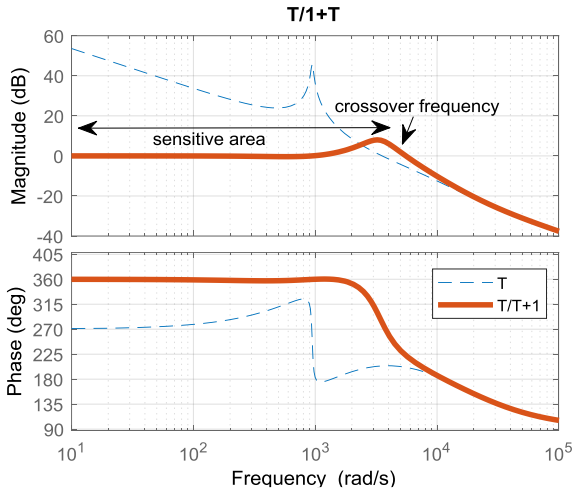

Fig.3 Loop gain T and T-related factor

Normally, the closed loop gain is designed to be large enough to make the output voltage follow the reference voltage. This means  $\|T\| \gg 1$ , so  $T/(1+T) \approx 1$ , which is depicted in Fig.3. Introducing droop control makes the output current variations coupled to the closed loop and enlarged by  $R_v$ . For the frequency lower than crossover frequency (sensitive area shown in the Fig.3), the amplitude of variations cannot be well suppressed due to the 0dB loop gain. The low frequency variations will be furtherly transmitted to output voltage, and theoretically, larger  $R_v$  will lead to larger variations according to the equation (6).

One effective method to avoid large output voltage variation is to add a low-pass filter on feedback current (denoted by  $I_{out}$ ),

$$I' = \frac{1}{1+\tau s} I_{out} \quad (\tau = \omega_c^{-1}) \quad (7)$$

where  $\omega_c$  is the filter cut-off frequency.

This method will suppress the low frequency variation caused by the grid-connected equipments and also extend the

maximum boundary of droop coefficient. Fig.4 shows the droop coefficient zone.

According to Fig.4, it can be seen that voltage variations increase as the droop coefficient increase. And this makes the droop coefficient stop by blue line and cannot reach previously-designed droop boundary. After adding low pass filter will make the variations minimized and the available droop boundary is extended as well.

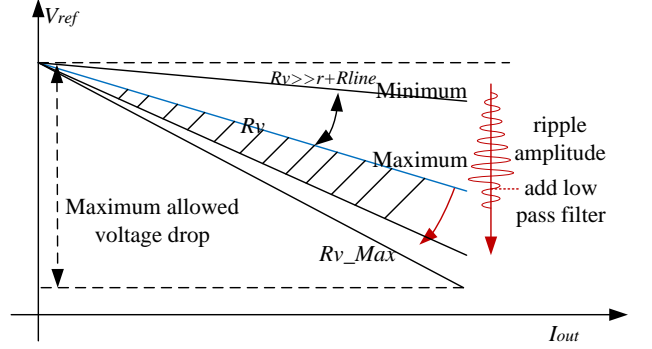

Fig.4 Droop coefficient zone

The maximum virtual resistance ( $R_{v\_Max}$ ) is usually designed from maximum allowed working voltage window according to the converter hardware design or control loop phase margin; however, it causes large enough variations to these DC bus voltage based control strategies that rely on the accuracy of circuit voltage sampling circuit before reaching its maximum value. Therefore, adding low pass filter before the feedback current path can effectively reduce the variations caused by feedback output current. Meanwhile, the boundary of droop coefficient is also enlarged due to the variation minimization as aforementioned.

### III. SIMULATIONS STUDY

A Matlab/Simulink DC microgrid simulation model was implemented for the analysis of discussed problems and validation of the proposed low pass filter method.

The nominal voltage reference is 50 V, the cut-off frequency of low pass filter is 20 Hz. A small disturbance current is created to test the response of the DC microgrid system. The parameters used in the simulation study are listed on Table I.

TABLE I. SIMULATION PARAMETERS

Type	Parameter	Value	Parameter	Value
Converter	$V_{in}$	25 V	$V_{out}$	50 V
	$L$	280 uH	$C$	1 mF
	$R_v$	[0.1-1]	$R_{load}$	25 ohm
	$H$	1/5		
Disturbance current	$I_D$	0.1 A	$f_D$	50, 100, 500, 1k, 2k (Hz)

The small current variations (0.1A) are parasitized with output current, the result of variations through closed loop gain is shown in following part.

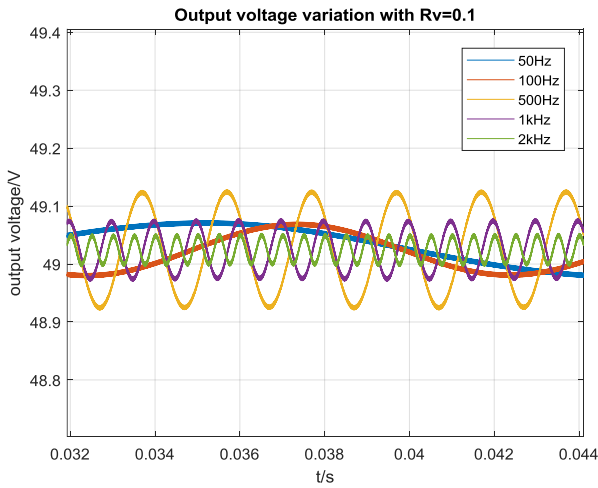

Fig.5 Output voltage variations with  $R_v=0.1$

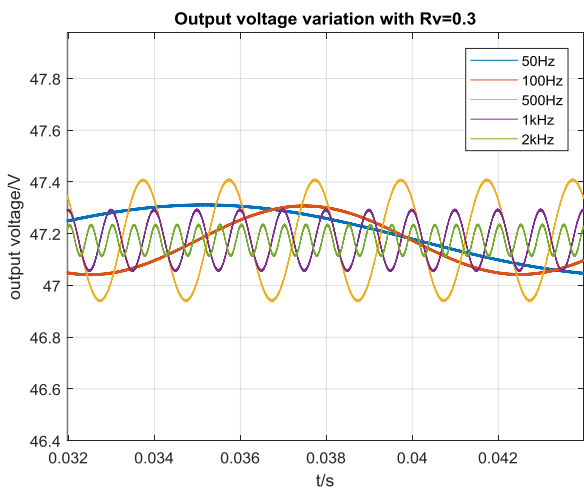

Fig.6 Output voltage variation with  $R_v=0.1$

Fig.5 shows the voltage variations caused by droop control with setting of the virtual resistance  $R_v=0.1$  is about 0.22 V (at 500Hz for example), when increasing the droop coefficient to 0.3 (see Fig.6), the amplitude of variations is also increased to 0.54 V (at 500 Hz for example). The lower frequencies (50 Hz and 100 Hz) voltage components have significant voltage variations with respect to the testing current.

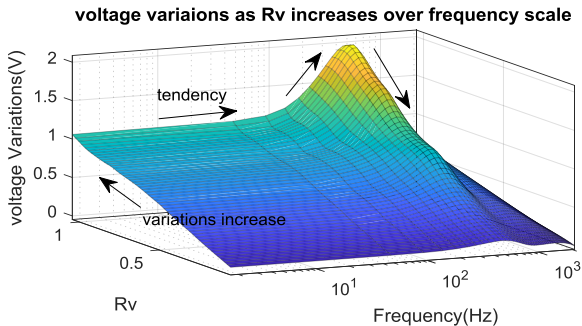

Fig.7 voltage variations as  $R_v$  increases over frequency scale

This means that introducing droop control results in weak suppression on the output current variations over lower

frequencies, which are normally contained in or coupled from grid-connected applications.

The impact of larger droop coefficient to voltage variations and the tendency over frequency scale is shown in Fig.7. It shows that the whole variations tendency over frequency scale is same as previously analyzed Bode plot as shown in Fig.3. Larger droop coefficient can make the variations increase with respect to the frequency. A declination of voltage variation occurs after the crossover frequency.

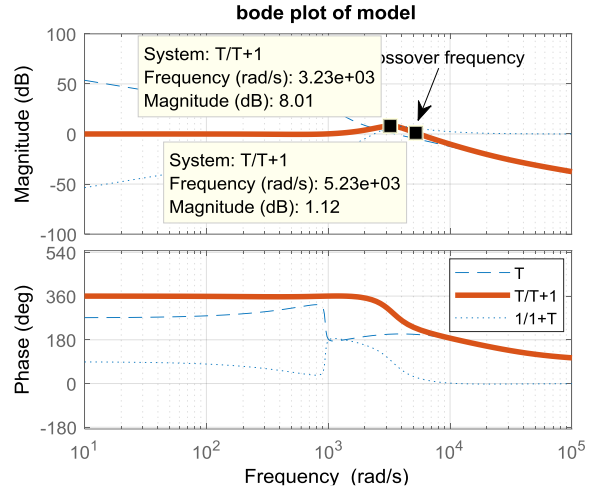

Fig.8 Bode plot of the simulated model

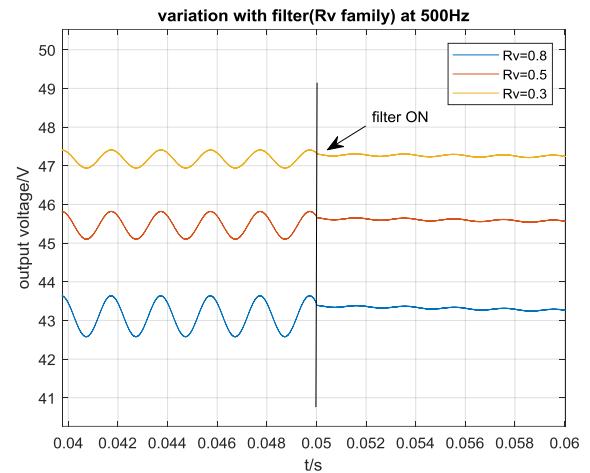

Fig.9 Output voltage variations with low pass filter

The equivalent resonant frequency is about 500Hz (3.23k rad/s) which is shown in Fig.8. This frequency gain is also the largest over the whole frequencies, which is about 8 dB. The crossover frequency is around 800Hz (5.23k rad/s), the variations after this frequency are well suppressed by the closed loop gain.

Adding low pass filter on the current feedback path can dramatically reduce the variations caused by introduced droop control. The simulation result is shown in Fig.9. It can be seen that the voltage variations (500 Hz for example) are reduced even with large droop coefficient, which means that the droop coefficient can reach the maximum boundary till it shifts quiescent operating point as discussed before.

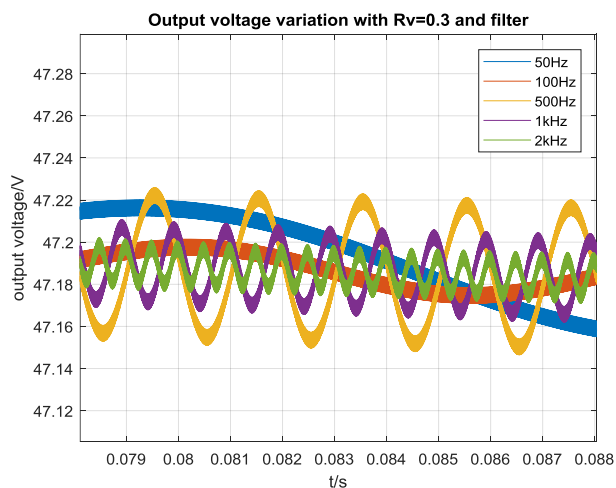

Fig.10 Output voltage variations with low pass filter with  $R_v=0.3$

A quantitative illustration is shown in Fig.10. The amplitudes of low frequencies are suppressed (only 0.06 V at 500 Hz peak to peak for example). As for the higher frequency over crossover frequency, it does not have significant impact due to previous large loop gain. Therefore, the variation over all frequency range are well suppressed so that the power quality and bus voltage based control methods can be guaranteed.

#### IV. CONCLUSIONS

This paper analyzes the impact of introducing droop control in DC microgrids for DC/DC interface converters. It shows that introducing droop control make the DC microgrid system more sensitive to low frequency variations contained in output current. A maximum droop coefficient is tracked and a low pass filter is proposed for reducing the variations and topping up the maximum droop coefficient. Simulation results validated the proposed system analysis and design.

#### REFERENCES

[1] J. M. Guerrero, J. C. Vasquez, J. Matas, L. G. de Vicuna and M. Castilla, "Hierarchical Control of Droop-Controlled AC and DC Microgrids—A General Approach Toward Standardization," in IEEE

Transactions on Industrial Electronics, vol. 58, no. 1, pp. 158-172, Jan. 2011.

[2] S. Augustine, M. K. Mishra and N. Lakshminarasamma, "Adaptive Droop Control Strategy for Load Sharing and Circulating Current Minimization in Low-Voltage Standalone DC Microgrid," in IEEE Transactions on Sustainable Energy, vol. 6, no. 1, pp. 132-141, Jan. 2015.

[3] D. Ghaderi and M. Çelebi, "Implementation of load sharing with fast voltage regulation in parallel connected cascaded power boost converters based on droop coefficients refreshing method," 2017 9th International Conference on Computational Intelligence and Communication Networks (CICN), Girne, 2017, pp. 195-199.

[4] Z. Zhang et al., "Droop control of a bipolar dc microgrid for load sharing and voltage balancing," 2017 IEEE 3rd International Future Energy Electronics Conference and ECCE Asia (IFEEC 2017 - ECCE Asia), Kaohsiung, 2017, pp. 795-799.

[5] P. Lin, P. Wang, Q. Xu, J. Xiao, I. U. Nutkani and Choo Fook Hoong, "An integral-droop based dynamic power sharing control for hybrid energy storage system in DC microgrid," 2017 IEEE 3rd International Future Energy Electronics Conference and ECCE Asia (IFEEC 2017 - ECCE Asia), Kaohsiung, 2017, pp. 338-343.

[6] C. Wang, J. Meng, Y. Wang and H. Wang, "Adaptive virtual inertia control for DC microgrid with variable droop coefficient," 2017 20th International Conference on Electrical Machines and Systems (ICEMS), Sydney, NSW, 2017, pp. 1-5.

[7] Peng Li, Wei Wang, Xilei Yang, Shuai Wang, Hongfen Cui and Changzheng Gao, "A droop control method of microsources based on divided self-adjusting slope coefficient," 2010 International Conference on Power System Technology, Hangzhou, 2010, pp. 1-6.

[8] Z. Ma and W. Jiang, "An adaptive droop voltage control for DC microgrid systems," The 26th Chinese Control and Decision Conference (2014 CCDC), Changsha, 2014, pp. 4512-4517.

[9] X. Lu, J. M. Guerrero, K. Sun and J. C. Vasquez, "An Improved Droop Control Method for DC Microgrids Based on Low Bandwidth Communication With DC Bus Voltage Restoration and Enhanced Current Sharing Accuracy," in IEEE Transactions on Power Electronics, vol. 29, no. 4, pp. 1800-1812, April 2014

[10] J. Schonberger, R. Duke and S. D. Round, "DC-Bus Signaling: A Distributed Control Strategy for a Hybrid Renewable Nanogrid," in IEEE Transactions on Industrial Electronics, vol. 53, no. 5, pp. 1453-1460, Oct. 2006

[11] F. Li, Z. Lin, Z. Qian and J. Wu, "Active DC bus signaling control method for coordinating multiple energy storage devices in DC microgrid," 2017 IEEE Second International Conference on DC Microgrids (ICDCM), Nuremberg, 2017, pp. 221-226.

[12] Z. Lin, J. Du, J. Wu and X. He, "Novel communication method between power converters for DC micro-grid applications," 2015 IEEE First International Conference on DC Microgrids (ICDCM), Atlanta, GA, 2015, pp. 92-96.