

Simulation of Inverter Fed Induction Motor Drive with LabVIEW

R. Gunabalan, S. Immanuel Prabakaran, J. Reegan, S. Ganesh

Abstract—This paper describes a software approach for modeling inverter fed induction motor drive using Laboratory Virtual Instrument Engineering Workbench (LabVIEW). The reason behind the selection of LabVIEW software is because of its strong graphical interface, flexibility of its programming language combined with built-in tools designed specifically for test, measurement and control. LabVIEW is generally used in most of the applications for data acquisition, test and control. In this paper, inverter and induction motor are modeled using LabVIEW toolkits. Simulation results are presented and are validated.

Keywords—Induction motor, LabVIEW, State model.

I. INTRODUCTION

MATHEMATICAL models of electrical machines are used to learn about their dynamic characteristics using simulation tools. With the advancement of computer technology, the drawbacks of conventional simulation methods become more and more obvious. With the rapid growth in computer hardware and software techniques, new user friendly simulation software packages are now available. Putting virtual instruments software into mathematical modeling and analysis of electrical machines will result in not only the cost reduction of the hardware but also the enhancement of the teaching or training effect. The direct application of this sort of software drastically simplifies simulation procedures for several practicing engineers.

LabVIEW programs are called Virtual Instruments (VI) because their appearance and operation imitate physical instruments, such as oscilloscopes and multi-meters. LabVIEW is a graphical programming language for data acquisition, analysis and presentation. The components of LabVIEW are front panel and block diagram. The front panel is built with controls and indicators and the block diagram contains the pictorial representation of source code.

At present, LabVIEW simplifies the scientific computation, process control, research, industrial applications and measurement applications.

MATLAB is a high performance language for technical computing. It integrates computation, visualization and programming in an easy-to-use environment where problems and solutions are expressed in familiar mathematical notation.

R. Gunabalan and S. Ganesh are with the department of Electrical and Electronics Engineering, Chandy College of Engineering, Thoothukudi, Anna University, Chennai, TamilNadu, India. (e-mail: gunabalan@yahoo.co.in, gauti_ganesh@yahoo.com)

S. Immanuel Prabakaran and J. Reegan are with the department of Electronics and Communication Engineering, Chandy College of Engineering, Thoothukudi, Anna University, Chennai, TamilNadu, India.

MATLAB simulink block sets are widely used in simulation of all kind of systems. MATLAB was used for simulation of vector control of induction motor and different electric motors [1]-[9]. But Simulink lack the imitation of physical instruments or equipment in appearance and operation. Considering the above, LabVIEW is used as a simulation tool to model inverter fed induction motor drive.

Field oriented control of induction motor drive using LabVIEW was discussed in [10] but simulation results were not explained clearly. LabVIEW was used to simulate and find the characteristics of synchronous generator [11] but the speed-torque characteristics were not explained. LabVIEW was used to identify the induction motor parameter [12], automatic testing for DC motor of portable washing machine [13], harmonic measurement [14], speed control of stepper motor [15], fault diagnosis of induction motor [16]-[17], etc. modeling of inverter and induction motor using LabVIEW is not discussed in literature.

In this paper, LABVIEW is used as a simulation tool to model the inverter and induction motor. The induction motor state equations are constructed in LabVIEW environment using control design and simulation toolkit, mathscript node and simple VIs. Inverter is constructed using simple VIs.

The paper is organized as follows: Chapter II discusses the inverter model in LabVIEW. The state space model of induction motor and results are discussed in Chapter III. Finally it is concluded in Chapter IV.

II. INVERTER MODEL

Voltage fed inverter receives DC voltage at one side and convert it to AC voltage. The AC voltage and frequency may be variable or constant depending on the application. Voltage fed inverter is used extensively for AC motor drive, induction heating, UPS etc. In voltage fed inverters, transistor family devices are generally preferred because of self commutation and high switching frequency. When a new converter circuit is developed, or a control strategy of a converter or drive system is formulated, it is often convenient to study the system performance by simulation before building the breadboard or prototype. The simulation not only validates the system's operation, but also permits optimization of the system's performance. Besides control and circuit parameters, the plant parameter variation effect can be studied. Fig. 1 shows the simple simulation block diagram for a three-phase, two-level PWM inverter. Each leg of the inverter is represented by a "switch" which has three input terminals and one output terminal.

The output of a switch (V_{a0} , V_{b0} or V_{c0}) is connected to the upper input terminal ($+0.5 V_d$) if the PWM control signal (middle input) is positive. Otherwise, the output is connected to the lower input terminal ($-0.5 V_d$). The output or V_{a0} voltage thus oscillates between $+0.5V_d$ and $-0.5V_d$, which is characteristics of a pole of an inverter. The output phase voltages are constructed by the following equations:

$$V_{an} = 2/3 V_{a0} - 1/3 V_{b0} - V_{c0} \quad (1)$$

$$V_{bn} = 2/3 V_{b0} - 1/3 V_{a0} - V_{c0} \quad (2)$$

$$V_{cn} = 2/3 V_{c0} - 1/3 V_{a0} - V_{b0} \quad (3)$$

$$V_{ab} = V_{an} - V_{bn} \quad (4)$$

$$V_{bc} = V_{bn} - V_{cn} \quad (5)$$

$$V_{ca} = V_{cn} - V_{an} \quad (6)$$

The state variables are d and q-axes stator currents and rotor fluxes.

$$i_{ds} = -\left(\frac{L_r R_s + L_m^2 / \tau_r}{\sigma L_s L_r}\right) i_{ds} + \omega_e i_{qs} + \left(\frac{L_m}{\sigma L_s L_r \tau_r}\right) \phi_{dr} + \left(\frac{L_m \omega_r}{\sigma L_s L_r}\right) \phi_{qr} + \left(\frac{1}{\sigma L_s}\right) V_{ds} \quad (9)$$

$$i_{qs} = -(\omega_e i_{ds}) - \left(\frac{L_r R_s + L_m^2 / \tau_r}{\sigma L_s L_r}\right) i_{qs} - \left(\frac{L_m \omega_r}{\sigma L_s L_r}\right) \phi_{dr} + \left(\frac{L_m}{\sigma L_s L_r \tau_r}\right) \phi_{qr} + \left(\frac{1}{\sigma L_s}\right) V_{qs} \quad (10)$$

$$\dot{\phi}_{dr} = \frac{L_m}{\tau_r} i_{ds} - \frac{1}{\tau} \phi_{dr} + (\omega_e - \omega_r) \phi_{qr} \quad (11)$$

$$\dot{\phi}_{qr} = \frac{L_m}{\tau_r} i_{qs} - (\omega_e - \omega_r) \phi_{dr} - \frac{1}{\tau} \phi_{qr} \quad (12)$$

Speed is calculated from the resultant stator currents and rotor fluxes. The equation for rotor speed is given by

$$\omega_r = \frac{3 n_p L_m}{2 J L_r} (\phi_{dr} i_{qs} - \phi_{qr} i_{ds}) - \frac{1}{J} T_L \quad (13)$$

The above state equations are constructed in LabVIEW using mathscript node inside the simulation loop. Steps:

1. Control and simulation loop is created
2. Mathscript node is constructed inside the simulation loop.
3. First order differential equations are written inside the mathscript node.
4. Integration is performed to find the different state variables.
5. By using simple arithmetic VIs, the speed and torque are calculated from the stator voltages and currents.
6. Three phase stator voltages are converted into two phase quantities in formula node.

A part of the block diagram codes framed in LabVIEW is shown in Fig. 2. The mathscript node, simple arithmetic VIs and scope for measurement are illustrated. Fig. 3 shows the speed and torque waveforms created in the front panel using graphical display. Initially the motor runs at no load speed. At $t=2.5s$, a load of 5 Nm is applied to the motor. As the motor runs at open loop condition, speed of the motor decreases from 1497 rpm to 1480 rpm. The dq-axes stator currents and rotor fluxes are considered as state variables. Fig. 4 shows the dq-axes stator phase currents. The dq-axes rotor fluxes are shown in Fig. 5. The output of the inverter contains harmonics. The dq-axes stator voltages are depicted in Fig. 6.

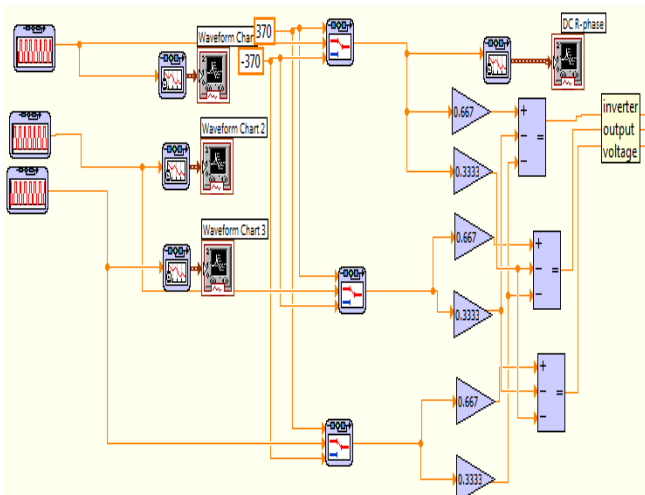

Fig. 1 Block diagram codes for modeling of inverter

III. INDUCTION MOTOR MODEL

State space equations are used to solve linear and non linear system equations. In state space representations, any n^{th} order differential equations describing a control system could be reduced to n^{1st} order equations. These equations are arranged in the form of matrix equations to find the solution easily using software tools. This method is named as the state variable method. The selection of state variables depends upon the system structure and the goals of study. The state variables chosen for induction motor are stator currents and rotor fluxes. Torque is calculated from the state variables and motor parameters. The continuous state space representation of the induction motor is as follows:

$$\frac{dX}{dt} = AX + BU \quad (7)$$

$$Y = CX \quad (8)$$

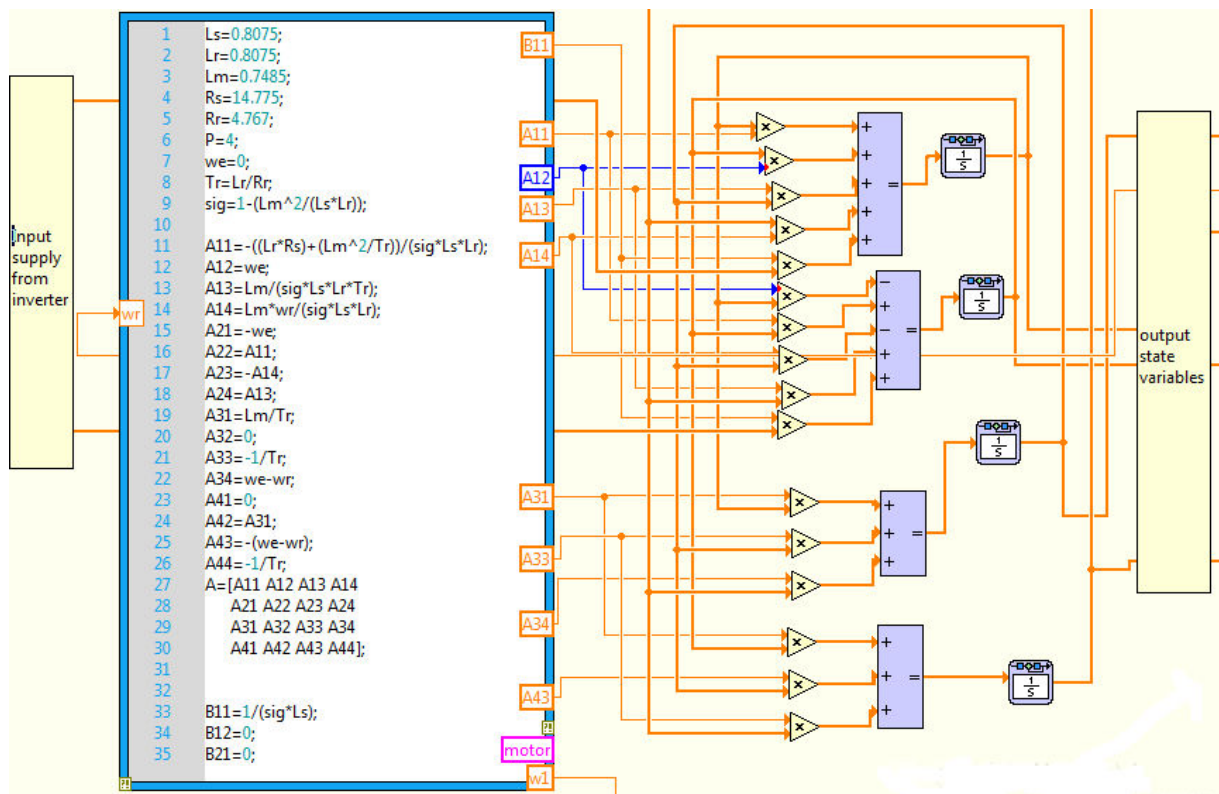

Fig. 2 Block diagram codes for modeling of induction motor

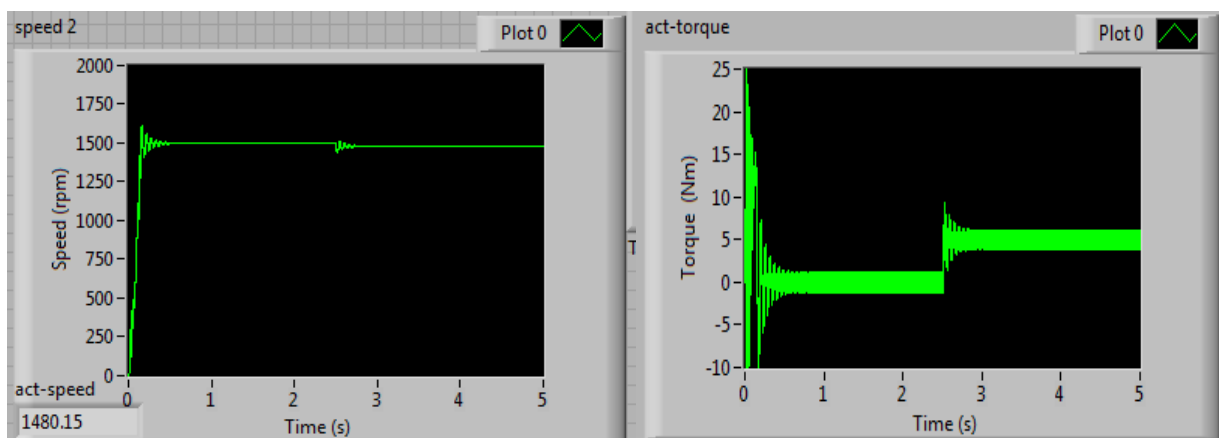

Fig. 3 Speed and torque waveforms of induction motor

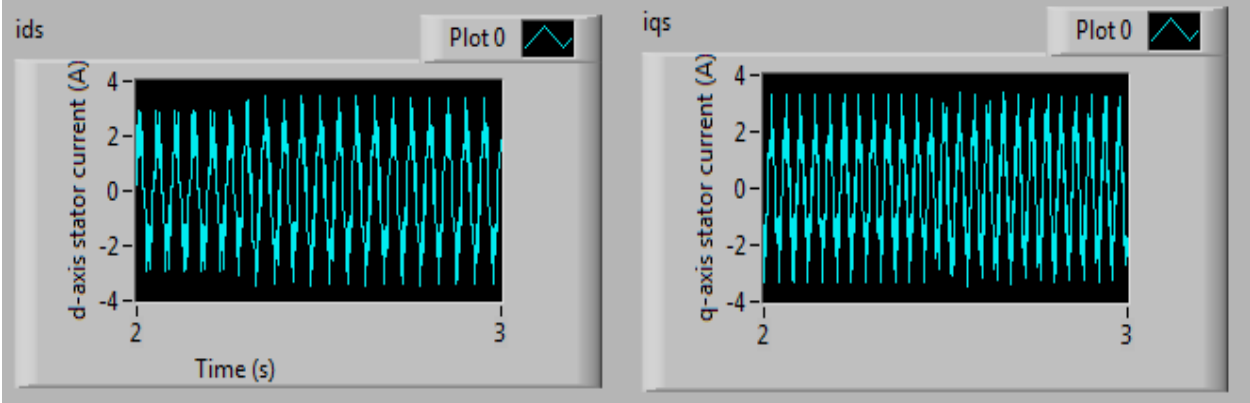

Fig. 4 dq axes stator phase currents

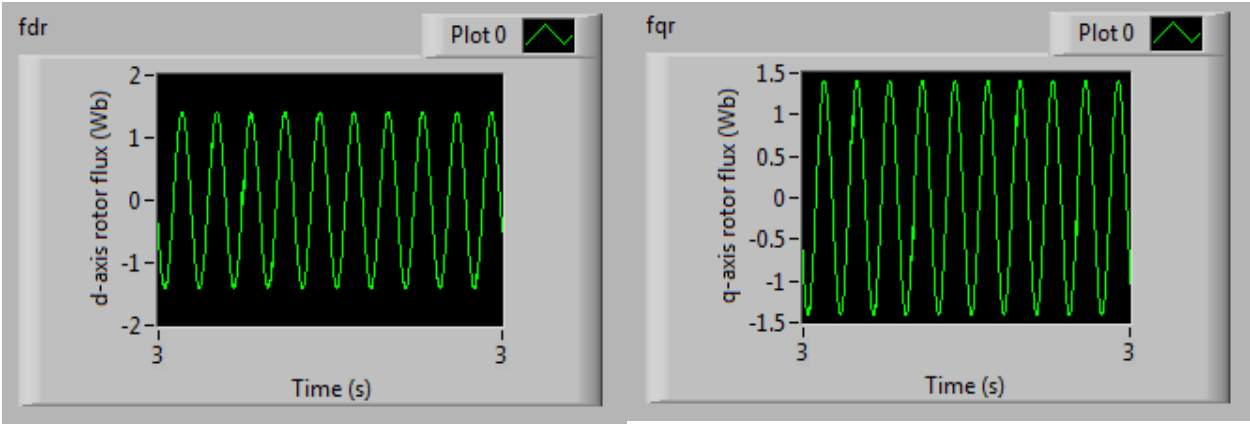

Fig. 5 dq axes rotor fluxes

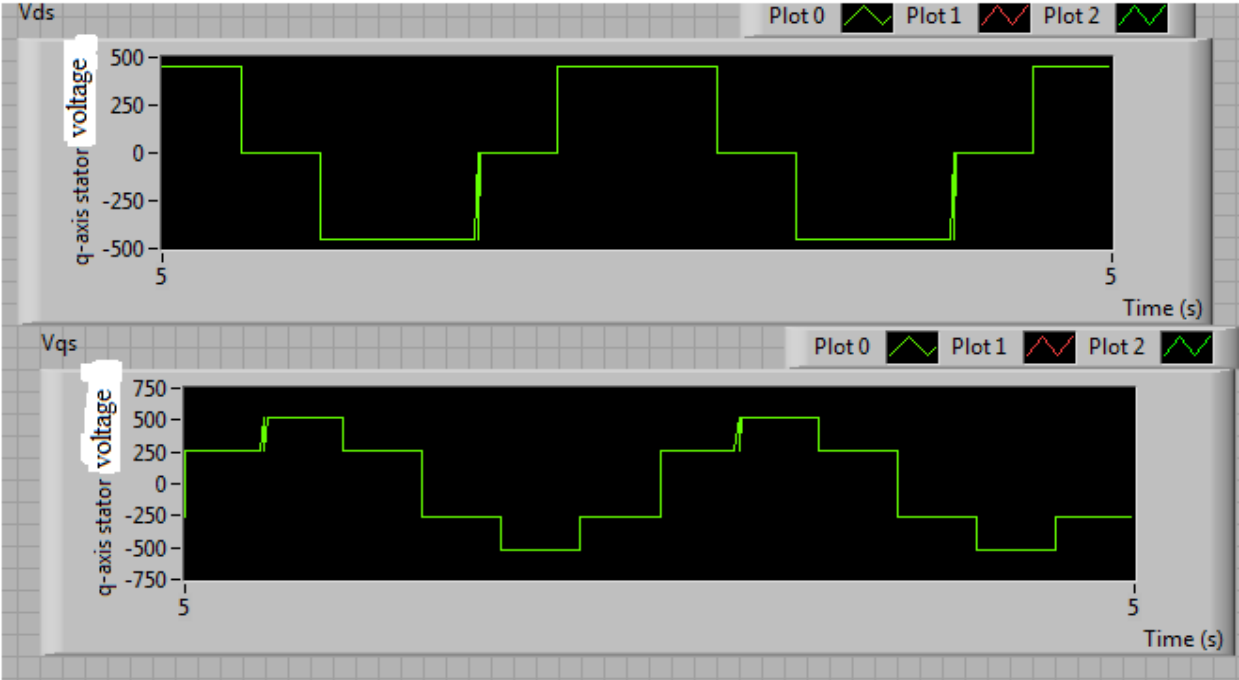

Fig. 6 dq axes stator voltages

International Science Index, Electrical and Computer Engineering Vol:8, No:1, 2014 waset.org/Publication/9997236

IV. CONCLUSION

In this work, the inverter and induction motor are modeled and simulated using LabVIEW. The models are constructed using simple VIs and mathscript node. To prove the effectiveness of the given method, simulation results are provided.

REFERENCES

- [1] G K. Matsuse, Y. Kouno, H. Kawai, J. Oikawa, "Characteristics of speed sensor-less vector controlled dual induction motor drive connected in parallel fed by a single Inverter", IEEE Trans. Ind. Appl., vol. 40, pp. 153-161, Jan./Feb. 2004.
- [2] K. Matsuse, Y. Kouno, H. Kawai, S. Yokomizo, "A Speed-sensor-less vector control method of parallel-connected dual induction motor fed by a single inverter", IEEE Trans. Ind. Appl., vol. 38, pp. 1566-1571, Nov./Dec. 2002.
- [3] H. Kubota K. Matsuse, "Speed sensorless field-oriented control of induction motor with rotor resistance adaptation", IEEE Trans. Ind. Appl., vol. 30, pp. 1219-1224, Sept. /Oct. 1994.
- [4] H. Kubota, K. Matsuse, T. Nakano, "DSP-Based Speed Adaptive Flux Observer of Induction Motor", IEEE Trans. Ind. Appl., vol. 29, pp. 344-348, Mar./Apr. 1993.
- [5] Sidney R. Bowes, Ata Sevinc, Derrick Holliday, "New natural observer applied to speed sensorless DC servo and induction motors", IEEE Trans. Ind. Appl., vol. 51, no.5, pp. 1025-1032, Oct. 2004.
- [6] Young-Real Kim, Seung-Ki Sul, Min-Ho Park, "Speed sensorless vector control of induction motor using Extended Kalman Filter", IEEE Trans. Ind. Appl., vol. 30, no. 5, pp.1225-1233, Sept. / Oct. 1994.
- [7] Luigi Salvatore, Silvio Stasi, Lea Tarchioni, "A new EKF-based algorithm for flux estimation in induction machines", IEEE Trans. Ind. Electron., vol.40, no.5, pp.496-504, Oct.1993.
- [8] Young-Real Kim, Seung-Ki Sul, Min-Ho Park, "Speed sensorless vector control of induction motor using Extended Kalman Filter", IEEE Trans. Ind. Appl., vol. 30, no. 5, pp.1225-1233, Sept. / Oct. 1994.
- [9] Murat Barut, Seta Bogosyan, Metin Gokasan, "Speed-sensorless estimation for induction motors using Extended Kalman Filters", IEEE Trans. Ind. Electron., vol. 54, no.1, pp. 272-280, Feb. 2007.
- [10] Tao Wu, Yi-Lim Chi, Yu Guo, Chao Xu, "Simulation of FOC vector control of induction motor based on LabVIEW", International conference on information engineering and computer science, IEEE, Dec 2009.
- [11] M.Usama Surdar, "Synchronous generator simulation using LabVIEW", Journal of world academic of science, engineering and technology, vol.39, pp.392-400, 2008.
- [12] F. Filippetti, S.Pirani, L.Tommasini, G. Franceschini, "A LabVIEW based virtual instrument for on line induction motor parameter identification", IEEE, pp.648-653.
- [13] Chien-Lung Cheng, J.C.Yeh, S.C.Chern, Yi-Hung Lan, "Automatic testing system based on LabVIEW for DC motor of portable washing machine", International Symposium on Ind. Electron., IEEE, pp.489-493, 2008.
- [14] Qiu Tang, Yaonan Wang, Siyu Guo, "Design of power system harmonic measurement system based on LabVIEW", Fourth international conference on natural computation, IEEE, pp.489-493, 2008.
- [15] A.Shuqiu Gong, B.Binhe, "LabVIEW based automatic rising and falling speed control of stepper motor", International conference on electrical machines and systems (ICEMS 2009).
- [16] Irahis Rodriguez, Roberto Alves, Victor Guzman, "Analysis of air gap flux to detect induction motor faults", Universities power engineering conference (UPEC'06), pp. 690-694, Sept.2006.
- [17] R. Supangat, N. Ertugrul, W. L.Soong, D. A. Gray, C. Hansen, J. Grieger, "Broken rotor bar fault detection in induction motors using starting current analysis", European conference on power electronics and applications, 2005.

R. Gunabalan obtained his B.E. in Electrical and Electronics Engineering in Government College of Engineering Tirunelveli, Manonmanium Sundaranar University, Tamilnadu, India, in 2000 and did his Master of Technology (Electrical Drives & Control) in Pondicherry Engineering College, Pondicherry University, India, in 2006.

He is having 11 years of teaching experience in various reputed institutions. He is currently pursuing his PhD in Anna University, Chennai, Tamilnadu, India. He is working as an Assistant Professor in the department of Electrical and Electronics Engineering, Chandy College of Engineering, Thoothukudi, Tamilnadu, India. He published 18 papers in national conferences, 8 papers in international conferences. He published 5 paper in international journals. He is working in the area of sensorless vector control and DSP control.

Mr. R. Gunabalan is a life member in ISTE.