

Magnetic Field Analysis for a Distribution Transformer with Unbalanced Load Conditions by using 3-D Finite Element Method

P. Meesuk, T. Kulworawanichpong, and P. Pao-la-or

Abstract—This paper proposes a set of quasi-static mathematical model of magnetic fields caused by high voltage conductors of distribution transformer by using a set of second-order partial differential equation. The modification for complex magnetic field analysis and time-harmonic simulation are also utilized. In this research, transformers were study in both balanced and unbalanced loading conditions. Computer-based simulation utilizing the three-dimensional finite element method (3-D FEM) is exploited as a tool for visualizing magnetic fields distribution volume a distribution transformer. Finite Element Method (FEM) is one among popular numerical methods that is able to handle problem complexity in various forms. At present, the FEM has been widely applied in most engineering fields. Even for problems of magnetic field distribution, the FEM is able to estimate solutions of Maxwell's equations governing the power transmission systems. The computer simulation based on the use of the FEM has been developed in MATLAB programming environment.

Keywords—Distribution Transformer, Magnetic Field, Load Unbalance, 3-D Finite Element Method (3-D FEM)

I. INTRODUCTION

TRANSFORMER is a device that can convert electrical voltage from one circuit at one side of the transformer winding to another voltage level in the circuit connected across the other side of the transformer winding. Between transformer's windings, there is no physical connection. The voltage transfer can be induced by the mean of electromagnetic phenomena. Transformers are either step-up or step-down types. They are used for changing the voltage level in order to satisfy the standard voltage level of power transmission and distribution systems. Transformers are vital so that the outage or failure of the transformers can cause some interruption or a wide area blackout. To use the transformer in electrical power applications, efficiency, stability and reliability of the transformers are necessary. To evaluate the

efficiency of the transformer is to determine magnetic field distribution which results in transformer's power losses. The magnetic field distribution depends on loading conditions. Due to the increasing electrical demand in industries transformers have been connected with various types of loads. Some are balanced but there are unbalanced loads. Refer to standard provided by Provincial Electric Authority of Thailand (PEA), an unbalanced load is defined by 20% of current magnitude different between phase pairs.

Finite Element Method (FEM) is one of the most popular numerical methods used for computer simulation. The key advantage of the FEM over other numerical methods in engineering applications is the ability to handle nonlinear, time-dependent and complex geometry problems. Therefore, this method is suitable for solving the problem of magnetic field distribution, the FEM is able to estimate solutions of Maxwell's equations governing the power transmission systems. Although the conventional methods are simpler than the use of the FEM, they are limited for the system of simple geometry. In practice, several material structures can be found within the distribution transformer. Employing the FEM can includes these effects by choosing material magnetic permeability for each additional structure domain. With this feature, the FEM is one of potential numerical simulation tools for analyzing magnetic field problems of combined material regions. To utilize the advantages of the 3-D Finite Element Method (3-D FEM) for handling the magnetic field problems, 3-D FEM model development and problem formulation need to be defined in magnetic field problems of distribution transformer.

In this paper, magnetic field modeling of distribution transformer is briefed in Section II. Section III is to illustrate the utilization of the 3-D FEM by using Galerkin approach for the magnetic field modeling described in Section II. The domain of study with the 3-D FEM can be discretized by using linear tetrahedron elements. Section IV gives simulation results of magnetic field distribution of distribution transformers in both balanced and unbalanced load conditions. This section also gives some discussion. The simulation conducted herein is based on the 3-D FEM method given in Section III. All the programming instructions are coded in MATLAB program environment. The last section gives conclusion.

P. Meesuk is with the School of Electrical Engineering, Institute of Engineering, Suranaree University of Technology, Nakhon Ratchasima, THAILAND (e-mail: tumpp_winner@hotmail.com).

T. Kulworawanichpong is with the School of Electrical Engineering, Institute of Engineering, Suranaree University of Technology, Nakhon Ratchasima, THAILAND (e-mail: thanatch@sut.ac.th).

P. Pao-la-or is with the School of Electrical Engineering, Institute of Engineering, Suranaree University of Technology, Nakhon Ratchasima, THAILAND (corresponding author to provide phone: 0-4422-4407; fax: 0-4422-4601; e-mail: padej@sut.ac.th).

II. MAGNETIC FIELD MODELING FOR A DISTRIBUTION TRANSFORMER

In magnetic field calculations, the magnetic vector potential (\mathbf{A}) carries a bundle of information consisting of magnetic field intensity (\mathbf{H}), and magnetic flux density (\mathbf{B}). For convenience, some assumptions are made as follows: the magnetic materials of the cores are isotropic, and the displacement currents are negligible due to low supply frequency (50 Hz). Hence, (1) describes the temporal and spatial variations of \mathbf{A} [1], [2]

$$\nabla^2 \mathbf{A} - \mu\sigma \frac{\partial \mathbf{A}}{\partial t} + \mu \mathbf{J}_0 = 0 \quad (1)$$

..., where μ is the magnetic permeability, σ is the electrical conductivity, and \mathbf{J}_0 is the applied current density.

This paper has considered the system governing by using the time-harmonic mode and representing the magnetic vector potential in complex form, $\mathbf{A} = A e^{j\omega t}$ [3], therefore,

$$\frac{\partial \mathbf{A}}{\partial t} = j\omega A$$

..., where ω is the angular frequency.

Refer to (1), by employing the complex form of the magnetic field and when considering the problem of three dimensions in cartesian coordinate (x, y, z), hence

$$\frac{\partial}{\partial x} \left(\frac{1}{\mu} \frac{\partial A}{\partial x} \right) + \frac{\partial}{\partial y} \left(\frac{1}{\mu} \frac{\partial A}{\partial y} \right) + \frac{\partial}{\partial z} \left(\frac{1}{\mu} \frac{\partial A}{\partial z} \right) - j\omega\sigma A + \mathbf{J}_0 = 0 \quad (2)$$

Analytically, there is no simple exact solution of the above equation. Therefore, in this paper the 3-D FEM is chosen to be a potential tool for finding approximate magnetic field solutions for the quasi-static partial differential equation described as in (2) [4], [5].

III. 3-D FEM FOR THE DISTRIBUTION TRANSFORMER

A. Discretization

This paper determines a 3 ϕ , Dy1, 400 kVA, 22kV/400V distribution transformer. Fig. 1 depicts the detail of the distribution transformer. The domain of study with the 3-D FEM can be discretized by using linear tetrahedron elements. This can be accomplished by using Solidworks for 3-D grid generation. Fig. 2 displays grid representation of the test system. The region domain consists of 24,107 nodes and 132,961 elements.

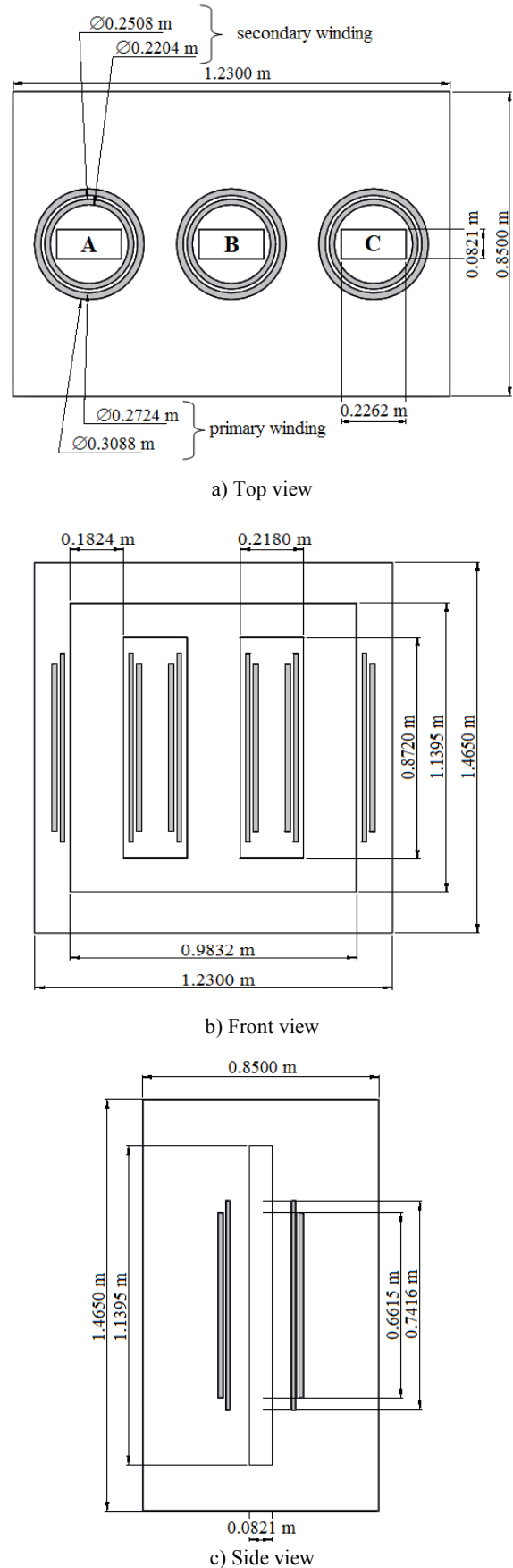

Fig. 1 Detail of the distribution transformer with dimension

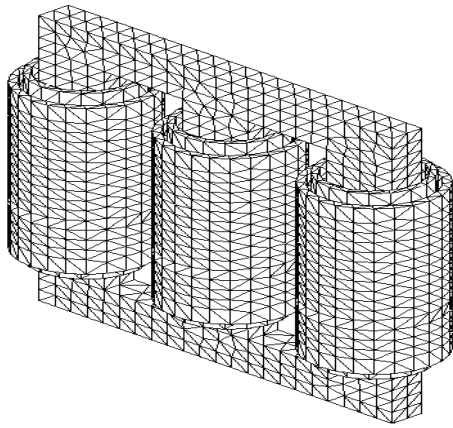

Fig. 2 Discretization of the system given in Fig. 1

B. 3-D FEM Formulation

An equation governing each element is derived from the Maxwell's equations directly by using Galerkin approach, which is the particular weighted residual method for which the weighting functions are the same as the shape functions. The shape function for 3-D FEM used in this research is the application of 4-node tetrahedron element (three-dimensional linear element) [6]-[8]. According to the method, the magnetic vector potential is expressed as follows

$$A(x, y, z) = A_1 N_1 + A_2 N_2 + A_3 N_3 + A_4 N_4 \quad (3)$$

..., where N_i , $i = 1, 2, 3, 4$ is the element shape function and the A_i , $i = 1, 2, 3, 4$ is the approximation of the magnetic vector potential at each node (1, 2, 3, 4) of the elements, which is

$$N_i = \frac{1}{6V} (a_i + b_i x + c_i y + d_i z)$$

..., where V is the volume of the tetrahedron element, which is expressed as

$$V = \frac{1}{6} \begin{vmatrix} 1 & x_1 & y_1 & z_1 \\ 1 & x_2 & y_2 & z_2 \\ 1 & x_3 & y_3 & z_3 \\ 1 & x_4 & y_4 & z_4 \end{vmatrix}$$

and

$$\begin{aligned} a_1 &= x_4(y_2 z_3 - y_3 z_2) + x_3(y_4 z_2 - y_2 z_4) + x_2(y_3 z_4 - y_4 z_3) \\ a_2 &= x_4(y_3 z_1 - y_1 z_3) + x_3(y_1 z_4 - y_4 z_1) + x_1(y_4 z_3 - y_3 z_4) \\ a_3 &= x_4(y_1 z_2 - y_2 z_1) + x_2(y_4 z_1 - y_1 z_4) + x_1(y_2 z_4 - y_4 z_2) \\ a_4 &= x_3(y_2 z_1 - y_1 z_2) + x_2(y_1 z_3 - y_3 z_1) + x_1(y_3 z_2 - y_2 z_3) \end{aligned}$$

$$b_1 = y_4(z_3 - z_2) + y_3(z_2 - z_4) + y_2(z_4 - z_3)$$

$$b_2 = y_4(z_1 - z_3) + y_1(z_3 - z_4) + y_3(z_4 - z_1)$$

$$b_3 = y_4(z_2 - z_1) + y_2(z_1 - z_4) + y_1(z_4 - z_2)$$

$$b_4 = y_3(z_1 - z_2) + y_1(z_2 - z_3) + y_2(z_3 - z_1)$$

$$c_1 = x_4(z_2 - z_3) + x_2(z_3 - z_4) + x_3(z_4 - z_2)$$

$$c_2 = x_4(z_3 - z_1) + x_3(z_1 - z_4) + x_1(z_4 - z_3)$$

$$c_3 = x_4(z_1 - z_2) + x_1(z_2 - z_4) + x_2(z_4 - z_1)$$

$$c_4 = x_3(z_2 - z_1) + x_2(z_1 - z_3) + x_1(z_3 - z_2)$$

$$d_1 = x_4(y_3 - y_2) + x_3(y_2 - y_4) + x_2(y_4 - y_3)$$

$$d_2 = x_4(y_1 - y_3) + x_1(y_3 - y_4) + x_3(y_4 - y_1)$$

$$d_3 = x_4(y_2 - y_1) + x_2(y_1 - y_4) + x_1(y_4 - y_2)$$

$$d_4 = x_3(y_1 - y_2) + x_1(y_2 - y_3) + x_2(y_3 - y_1)$$

The method of the weighted residue with Galerkin approach is then applied to the differential equation, refer to (2), where the integrations are performed over the element domain Ω .

$$\int_{\Omega} N_i \left(\frac{\partial}{\partial x} \left(\frac{1}{\mu} \frac{\partial A}{\partial x} \right) + \frac{\partial}{\partial y} \left(\frac{1}{\mu} \frac{\partial A}{\partial y} \right) + \frac{\partial}{\partial z} \left(\frac{1}{\mu} \frac{\partial A}{\partial z} \right) \right) d\Omega - \int_{\Omega} N_i (j\sigma\omega A) d\Omega + \int_{\Omega} (N_i J_0) d\Omega = 0$$

, or in the compact matrix form

$$[M + K]\{A\} = \{F\} \quad (4)$$

$$M = j\omega\sigma \int_{\Omega} N_i N_j d\Omega$$

$$= \frac{j\omega\sigma V}{20} \begin{bmatrix} 2 & 1 & 1 & 1 \\ 1 & 2 & 1 & 1 \\ 1 & 1 & 2 & 1 \\ 1 & 1 & 1 & 2 \end{bmatrix}$$

$$\{F\} = J_0 \int_{\Omega} N_i d\Omega = \frac{J_0 V}{4} \begin{bmatrix} 1 \\ 1 \\ 1 \\ 1 \end{bmatrix}$$

$$K = \frac{1}{\mu} \int_{\Omega} \left(\frac{\partial N_i}{\partial x} \frac{\partial N_j}{\partial x} + \frac{\partial N_i}{\partial y} \frac{\partial N_j}{\partial y} + \frac{\partial N_i}{\partial z} \frac{\partial N_j}{\partial z} \right) d\Omega$$

$$= \frac{1}{36\mu V} \begin{bmatrix} b_1b_1 + c_1c_1 + d_1d_1 & b_1b_2 + c_1c_2 + d_1d_2 \\ b_1b_2 + c_1c_2 + d_1d_2 & b_2b_2 + c_2c_2 + d_2d_2 \\ b_1b_3 + c_1c_3 + d_1d_3 & b_2b_3 + c_2c_3 + d_2d_3 \\ b_1b_4 + c_1c_4 + d_1d_4 & b_2b_4 + c_2c_4 + d_2d_4 \\ b_1b_3 + c_1c_3 + d_1d_3 & b_1b_4 + c_1c_4 + d_1d_4 \\ b_2b_3 + c_2c_3 + d_2d_3 & b_2b_4 + c_2c_4 + d_2d_4 \\ b_3b_3 + c_3c_3 + d_3d_3 & b_3b_4 + c_3c_4 + d_3d_4 \\ b_3b_4 + c_3c_4 + d_3d_4 & b_4b_4 + c_4c_4 + d_4d_4 \end{bmatrix}$$

For one element containing 4 nodes, the expression of the FEM approximation is a 4x4 matrix. With the account of all elements in the system of n nodes, the system equation is sizable as the $n \times n$ matrix.

IV. 3-D FEM SIMULATION RESULT

This paper conducts the simulation study by considering the 3 ϕ , Dy1, 400 kVA, 22kV/400V distribution transformer in both balanced and unbalanced loading conditions. In case of unbalanced loads, it can be divided into unbalance in magnitude and phase. For magnitude unbalance, the current of phase A is given as the rated value while those of phase B and C are assigned as +20% and -20% of the rated current, respectively. In case of unbalance phase, the current's angle of phase A is set as 0° while those of phase B and C are assigned as $+30^\circ$ and -30° , respectively. The boundary conditions applied here is zero magnetic vector potential at the transformer tank [9]. This simulation uses the system frequency of 50 Hz. The transformer core material is cold rolled silicon steel [10], having the conductivity (σ) = 2.08×10^6 S/m, and the relative permeability (μ_r) = 3000. It notes that the free space permeability (μ_0) is $4\pi \times 10^{-7}$ H/m.

The FEM-based simulation conducted in this paper is coded with MATLAB programming for calculation of magnetic field dispersion. The curl of the magnetic vector potential \mathbf{A} is magnetic flux density \mathbf{B} ($\mathbf{B} = \nabla \times \mathbf{A}$). For which 3-D FEM result, that can be graphically presented in the filled polygon of magnetic fields dispersed thoroughly the volume of study. Fig. 3-5 show the magnetic vector potential plot of the transformer coil for load balancing case, magnitude unbalance case, and phase unbalance case, respectively. Fig. 6-8 show the magnetic vector potential plot of the transformer core for load balancing case, magnitude unbalance case, and phase unbalance case, respectively. Fig. 9-11 show the magnetic flux density plot of the transformer core for load balancing case, magnitude unbalance case, and phase unbalance case, respectively.

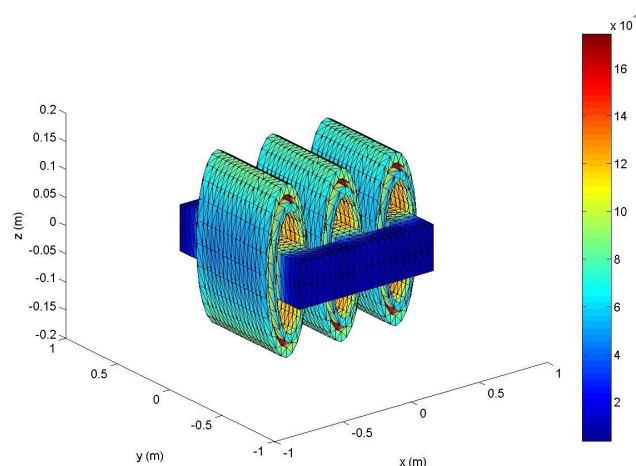

Fig. 3 Magnetic vector potential distribution (wb//m) of the transformer coil for load balancing case

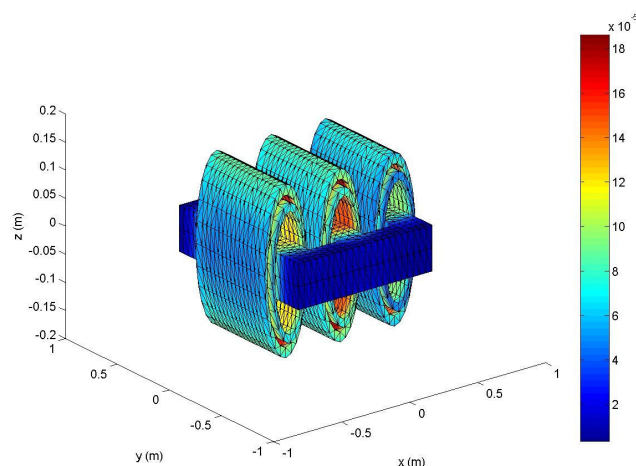

Fig. 4 Magnetic vector potential distribution (wb//m) of the transformer coil for magnitude unbalance case

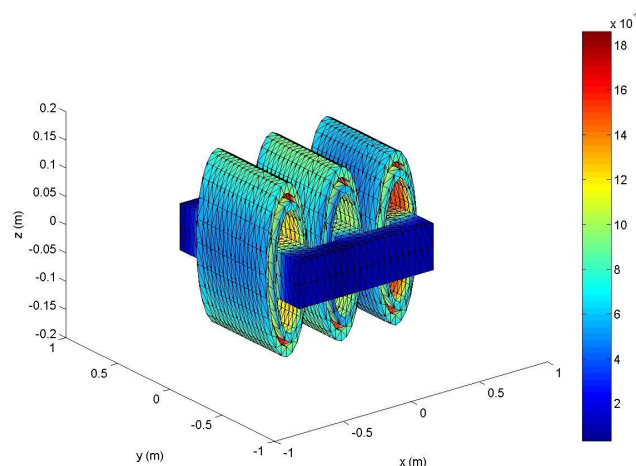

Fig. 5 Magnetic vector potential distribution (wb//m) of the transformer coil for phase unbalance case

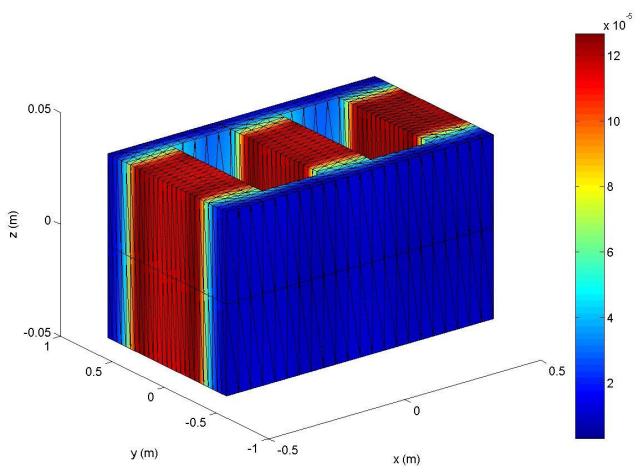

Fig. 6 Magnetic vector potential distribution (wb/m) of the transformer core for load balancing case

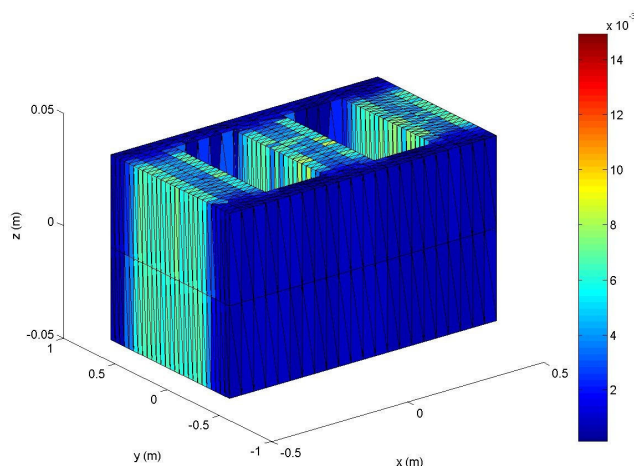

Fig. 9 Magnetic flux density distribution (T) of the transformer core for load balancing case

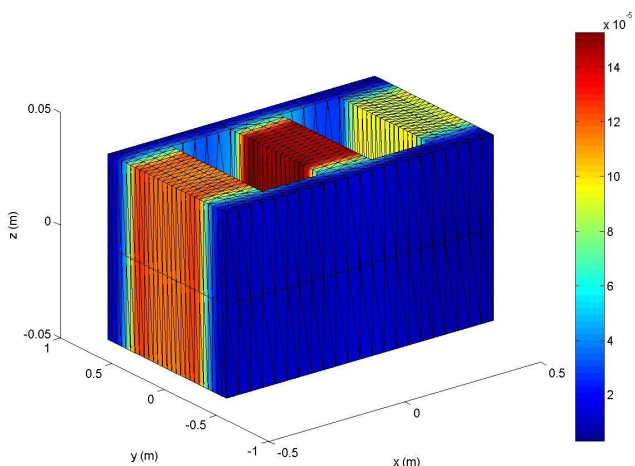

Fig. 7 Magnetic vector potential distribution (wb/m) of the transformer core for magnitude unbalance case

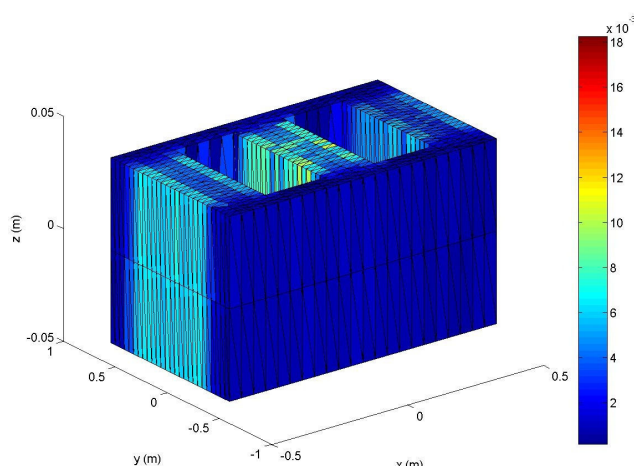

Fig. 10 Magnetic flux density distribution (T) of the transformer core for magnitude unbalance case

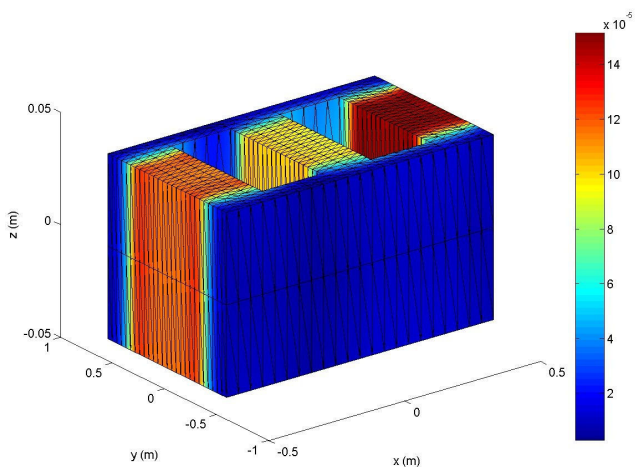

Fig. 8 Magnetic vector potential distribution (wb/m) of the transformer core for phase unbalance case

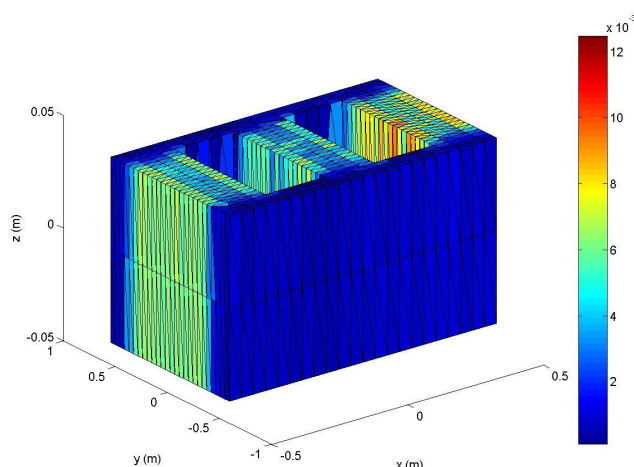

Fig. 11 Magnetic flux density distribution (T) of the transformer core for phase unbalance case

From which the results of magnetic vector potential that distribute throughout the transformer for balanced load case, magnitude unbalance case, and phase unbalance case as shown in Fig. 3-5. As can be seen, in all cases the magnetic vector potential has the maximum value at the transformer coils. This is because the coils are energized by the transformer's input current. The magnetic vector potential at the transformer coil induced the magnetic vector potential at the transformer core. This can be considered as shown in Fig. 6-8. The magnetic vector potential at the transformer core is relative to the magnetic vector potential at the transformer coil.

When considering the magnetic vector potential of the load balance case as shown in Fig. 3 and Fig. 6, the magnetic vector potential distributed symmetrically throughout the transformer volume due to balanced three-phase currents. For magnitude unbalance case, the magnetic vector potential is shown in Fig. 4 and Fig. 7. They illustrated that magnetic vector potential distribution is unsymmetrical at the transformer coil and the transformer core. The magnetic vector potential is high at phase B while that of phase C is low according to their current values. The phase unbalance case is shown in Fig. 5 and Fig. 8. The distribution of the magnetic vector potential is also unsymmetrical according to their phase values.

In Fig. 9-11, the magnetic flux density distributed in the transformer core when considering the load balance case, the magnitude unbalance case, and the phase unbalance case. As can be seen, the magnetic flux density is relative to the magnetic vector potential. In other word, the magnetic flux density is the rate of change in the magnetic vector potential.

V. CONCLUSION

This paper has studied the magnetic field distribution throughout the volume of the distribution transformer resulting from loading conditions of balance and unbalance. The unbalanced load conditions can be divided into magnitude unbalance case and phase unbalance case. 3 ϕ , Dy1, 400 kVA, 22kV/400V distribution transformer were investigated. The computer simulation is performed by using 3-D Finite Element Method (3-D FEM) instructed in MATLAB programming codes. As a result, distribution of the magnetic vector potential and the magnetic flux density throughout the volume of the transformer are symmetrical when the load is balanced. It is the unsymmetrical distribution of which the magnitude unbalance case and phase unbalance case. This confirmed that the magnetic flux density is the rate of change in the magnetic vector potential.

REFERENCES

- [1] N.A. Demerdash and D.H. Gillott, "A new approach for determination of eddy current and flux penetration in nonlinear ferromagnetic materials," *IEEE Transactions on Magnetics*, Vol.74, pp. 682-685, 1974.
- [2] W.N. Fu, *Electromagnetic field analysis of induction motors by finite element method and its application to phantom loading*, Ph.D. Thesis, Hong Kong Polytechnic University, China, 1999.
- [3] C. Christopoulos, *The Transmission-Line Modeling Method: TLM*, IEEE Press, USA, 1995.

- [4] P. Pao-la-or, T. Kulworawanichpong, S. Sujitjorn and S. Peaiyoung, "Distributions of Flux and Electromagnetic Force in Induction Motors: A Finite Element Approach," *WSEAS Transactions on Systems*, Vol. 5, No. 3, pp.617-624, 2006.
- [5] P. Pao-la-or, A. Isaramongkolrak and T. Kulworawanichpong, "Finite Element Analysis of Magnetic Field Distribution for 500-kV Power Transmission Systems," *Engineering Letters*, Vol. 18, No. 1, pp.1-9, 2010.
- [6] R.W. Lewis, P. Nithiarasu and K.N. Seetharamu, *Fundamentals of the Finite Element Method for Heat and Fluid Flow*, John Wiley & Sons, USA, 2004.
- [7] M.A. Bhatti, *Advanced Topics in Finite Element Analysis of Structures*, John Wiley & Sons, USA, 2006.
- [8] P.I. Kattan, *MATLAB Guide to Finite Elements (2nd edition)*, Springer Berlin Heidelberg, USA, 2007.
- [9] S.V. Kulkarni and S.A. Khaparde, *Transformer engineering design and practice*, Marcel Dekker, USA, 2004.
- [10] V.N. Mittle, and A. Mittle, *Design of electrical machines*, Standard Publishers, 1996.