

# Study on Performance of Wigner Ville Distribution for Linear FM and Transient Signal Analysis

Azeemsha Thacham Poyil, Nasimudeen KM

**Abstract**—This research paper presents some methods to assess the performance of Wigner Ville Distribution for Time-Frequency representation of non-stationary signals, in comparison with the other representations like STFT, Spectrogram etc. The simultaneous time-frequency resolution of WVD is one of the important properties which makes it preferable for analysis and detection of linear FM and transient signals. There are two algorithms proposed here to assess the resolution and to compare the performance of signal detection. First method is based on the measurement of area under time-frequency plot; in case of a linear FM signal analysis. A second method is based on the instantaneous power calculation and is used in case of transient, non-stationary signals. The implementation is explained briefly for both methods with suitable diagrams. The accuracy of the measurements is validated to show the better performance of WVD representation in comparison with STFT and Spectrograms.

**Keywords**—WVD: Wigner Ville Distribution, STFT: Short Time Fourier Transform, FT: Fourier Transform, TFR: Time-Frequency Representation, FM: Frequency Modulation, LFM Signal: Linear FM Signal, JTFA: Joint time frequency analysis.

## I. INTRODUCTION

THE classical methods of representing signals in frequency domain through Fourier transformation does not give a good resolution in case of a non-stationary signals like speech signal or Radar signals. Here we have to find a more effective representation, which gives us an accurate view of the time and frequency information of the signal. This leads us to go for the advantages provided by WVD to the signal processing world. The previous works on WVD does not deal with any measurement techniques to compare the resolution accuracy with other TFRs. A visual identification of the WVD plot cannot be used as a standard method to assess the time-frequency resolution. There must be a standard set of parameters which can be mathematically calculated and used to decide which TRF representation is better in a specific context. So, this paper concentrates on two evaluation methods to measure the resolution of different classes of signals [1].

Azeemsha Thacham Poyil is working as Lecturer in the College of Computers and IT in Taif University, Saudi Arabia (e-mail: azeemsha.tp@gmail.com).

Nasimudeen KM is working as Lecturer in the College of Computers and IT in Taif University, Saudi Arabia

## II. OVERVIEW ON TIME-FREQUENCY REPRESENTATIONS

A joint time frequency analysis (JTFA) can be used to analyse a non-stationary signal, which shows the different frequencies contained by the signal, and also at what time these frequencies occur. Time-Frequency Distribution (TFD) of a signal is usually represented in a three dimensional diagram, with time along the x-axis, frequency along the y-axis, and magnitude or phase of the signal represented along the z-axis. The common applications of TFR are in the fields of speech synthesis, radar detection and medical analysis of non-stationary and nonlinear signals [2], [3], [5], [6].

Even though most of the TFR are capable of providing a good localization either in time or in frequency, it is not found possible in both time and frequency simultaneously. If the time accuracy is increased, the frequency accuracy is found to be decreased, and vice versa. So there is a need of TFR representation, where a better performance is required for an accurate signal analysis. WVD plays the role here.

### A. Short Time Fourier Transform

Short-Time Fourier Transform is a linear time-frequency transform, which is calculated by applying the Fourier Transform to a signal  $s(t)$  around a particular time 't', after pre-windowing it by a window function  $w(t)$ .

$$STFT_x(t, \nu) = \int_{-\infty}^{+\infty} s(u)w(u-t)e^{-j2\pi\nu u} du \quad (1)$$

Here  $\nu$  stands for frequency of the signal. The localization in time using STFT is dependent on the effective width of the window  $w(t)$ . And the localization in frequency using STFT is dependent on the width of the window function in frequency domain (bandwidth). This means that, for a good time localization it needs a short window function  $w(t)$  and a good frequency localization needs a window having narrow-band response. So there is always a compromise to do between time and frequency resolutions in case of STFT representations [2], [3], [5], [6].

### B. Spectrogram

Spectrogram of a signal is calculated by doing squared modulus of the STFT. The result will be a energy density in the spectral domain of the signal  $s(t)$  after applying a window function  $w(t)$ .

$$S_x(t, \nu) = \left| \int_{-\infty}^{+\infty} s(u)w^*(u-t)e^{-j2\pi\nu u} du \right|^2 \quad (2)$$

Spectrogram will be a real-valued and non-negative distribution. The spectrogram can be interpreted as a representation of the energy of the signal in the time-frequency domain centred on the point  $(t, \nu)$  [4], [5], [6].

Since the spectrogram is calculated similar to the STFT, time-frequency localization of spectrogram is also limited like in STFT. So, in comparison with STFT the time-frequency resolution is again poor in this representation.

### C. Wigner Ville Distribution

Wigner-Ville distribution (WVD) is a bilinear distribution and for any signal  $s(t)$ , the WVD is defined as,

$$WVD_x(t, \nu) = \int_{-\infty}^{+\infty} s(t + \tau/2) s^*(t - \tau/2) e^{-j2\pi\nu\tau} d\tau \quad (3)$$

Where  $t$  corresponds to time,  $\nu$  corresponds to frequency. The plot of WVD will be a 3-D figure with the time and frequency along  $x$  and  $y$  axes respectively, and the magnitude of WVD along the  $z$  axis as shown in Fig. 1

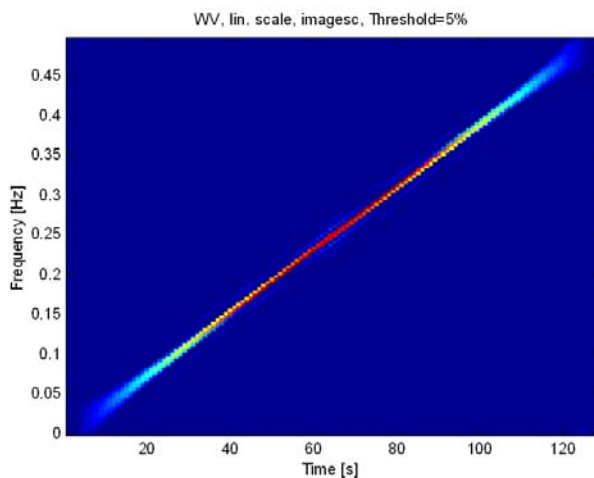

Fig. 1 Top View - 3D Image of WVD of LFM signal

The calculation of WVD does not require any windows (only the signal itself is required for the calculation) and this is one major difference between WVD and Short Time Fourier Transform [5], [6]. Some of the other important features of Wigner Ville Distribution are:

- 1) Integrating WVD over time gives the power density at a given frequency of the signal.
- 2) Integrating the WVD of a signal over frequency gives the instantaneous power at a given time.
- 3) Integrating WVD over both time and frequency gives the total energy of the signal.
- 4) WVD function is a real-valued.

WVD does not satisfy the linear superposition principle and this implies that, the WVD of a sum of two signals with different characteristics is not the same as the sum of the WVD of individual signal components. The terms due to the individual signals are called "auto-terms" and the additional terms due to the mathematical calculation are called "cross terms". If a signal is represented as the addition of two independent signal components, then

$$s(t) = s_1(t) + s_2(t) \quad (4)$$

Substituting this into (3), will give rise to the Cross-Wigner Ville terms  $W_{s_1s_2}(t, \nu)$  and  $W_{s_2s_1}(t, \nu)$ . These are complex terms. Since,  $W_{s_1s_2} = W_{s_2s_1}$ , the cross terms can be represented as  $2\text{Real}\{W_{s_1s_2}(t, \nu)\}$ . The cross-terms usually oscillate and its magnitude is double that of the auto-terms. So they have an impact on the useful time-dependent spectrum patterns of the signal. Even though these terms are mathematically correct, they appear as interference patterns, in the time-frequency diagram. So it will be difficult to make a visual interpretation of the results. There are many methods proposed to filter out these unwanted cross terms from the WVD, which itself is another area of research [9].

## III. WVD BASED ALGORITHMS

### A. Algorithm I: For Linear FM Signals

A linear FM signal is one which has the signal frequency varying linearly with time. The algorithm for validating the resolution of linear FM signals is based on the area under the time-frequency plot, as a measurement parameter. Here, the area under the WVD plot of an LFM signal is calculated and used to prove the improvement in time-frequency resolution in comparison with the other TFR's like Short Time Fourier Transform and Spectrogram. The calculation of area under the plot requires a certain threshold value to be set for the amplitude of the calculated TFR. The points on the plot which are out of bound of this threshold amplitude are not considered for the calculation of the area parameter. The value of the threshold may be changed specific to a context. The result of this area calculation further leads to a decision making on, whether the resolution is acceptable or not. This result can be used for the comparison of performances between WVD and Spectrogram [8], [12], [13].

### B. Algorithm II: For Transient Signals

Transient signals are usually non-stationary signals where the time of arrival of the signal cannot be known or predicted and the time duration of transient signals will be short compared to the observation interval. Most of the practical signals are found to be transients that are polluted by noise [7], [9]. Even though the detection and analysis of transient signals can be done by using STFT or Wavelet Transform, there is a major limitation here. Since the signal occurrence time is not known, it is not possible to determine and use a window function in an optimal way. This results in a bad performance in the detection of transients. So, in case of speech/transient signals which are having spectra varying as time progresses, we have to go for a different algorithm.

To achieve a good performance for the detection of transient signals, the sensitivity of the detecting mechanism must not be strongly dependent on the signal duration. The parameter for detection of such signals must be invariant to the signal duration. When the time duration of the transient signal changes, this corresponds to a change in the total signal energy. This means that the magnitude of the peak of the signal spectrum will be affected. So, if the pulse width of the transient signal is reduced, there will be a corresponding decrease in magnitude of the peaks of TFRs, at that frequency and time.

WVD of a signal can be used to get an estimate of the instantaneous signal power. So we are trying to make use of the time-marginal property of WVD to calculate the instantaneous signal power. The time marginal property of WVD is defined as,

$$\int_{-\infty}^{+\infty} W_x(t, \nu) d\nu = |x(t)|^2 \quad (5)$$

From the equation, it is clear that, the instantaneous signal power is obtained by integrating WVD over the frequency. And the resultant quantity  $|x(t)|^2$  does not depend on the time duration of the signal, and it only represents the amplitude of the signal. So the instantaneous signal power calculated from the WVD of the signal is the parameter used for transient signal detection in this paper. An equivalent equation for the Spectrogram gives the average signal energy over the duration of the window  $h(t)$  as shown.

$$\int_{-\infty}^{+\infty} S_x(t, \nu) d\nu = \int_{-\infty}^{+\infty} |x(\tau)|^2 |h(\tau - t)|^2 d\tau \quad (6)$$

This means that the time marginal of Spectrogram is strongly dependent on the time duration of the transient signal, because there is a time window associated. This results in a reduced performance of Spectrogram in comparison with WVD [10], [11], [14], [1].

#### IV. COMPARISON OF RESULTS

For the algorithm 1, after computing the area under the plot, a decision block looks for the area to be minimal or tending to zero, to assess the resolution as 'good'. The resolution will be ideally 100% if the area becomes zero. The experimental setup for the algorithm 1 is shown in Fig. 2.

In case of the algorithm 2, after computing the WVD of the transient signal, and integrating it over the frequency domain, the maximum value of the result is noted. This value is compared against the detection threshold for transient detection. The similar experiment is conducted by applying Spectrogram for the same transient signal and the results are compared. The experimental setup for the algorithm 2 is shown in Fig. 3.

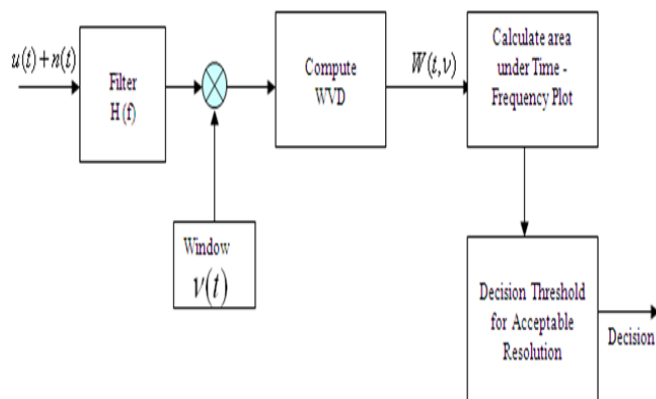

Fig. 2 Setup for calculation of area using WVD

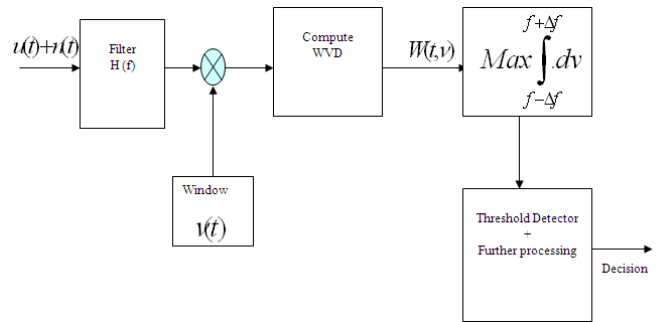

Fig. 3 Setup for transient signal detection using WVD

For algorithm 1, the results are captured after applying both WVD and Spectrogram for the LFM signal. The plots are drawn with the same scale/units in both examples, in time and frequency axes. The calculation of area under the plots of Spectrogram and WVD for the same LFM signal is shown in Fig. 4 and Fig. 5 respectively.

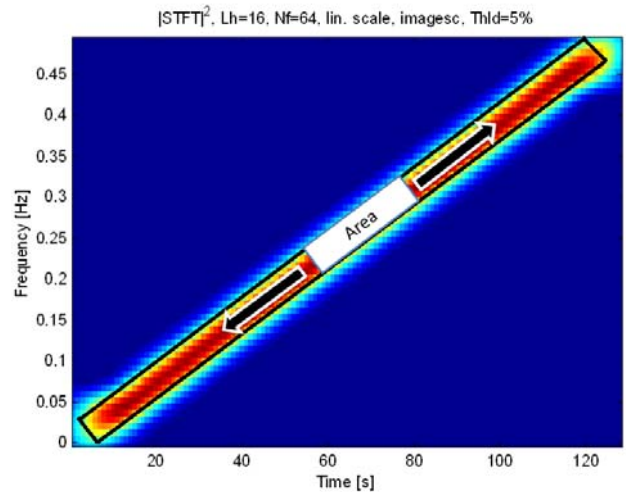

Fig. 4 Area under Spectrogram plot of LFM signal

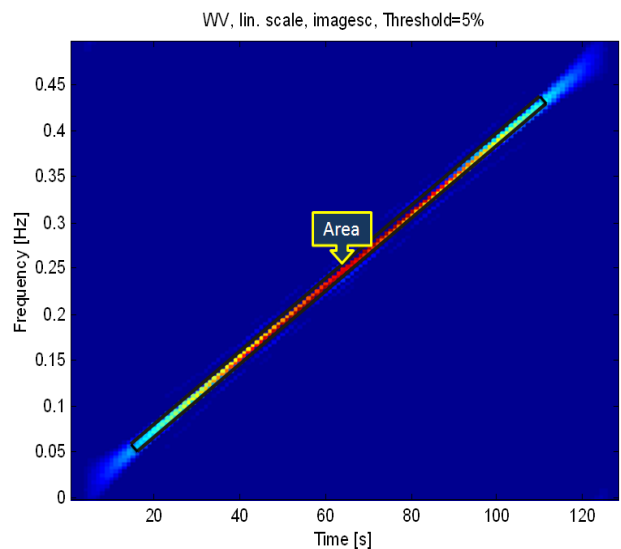

Fig. 5 Area under WVD plot of LFM signal

In case of algorithm 2, the time marginal (the instantaneous power) is calculated and plotted against time using WVD and STFT separately. The Fig. 6 shows the comparison of results between the two. It is clear that the peak amplitude of instantaneous power using WVD is higher than that with STFT. This difference in the peaks is the validation parameter to assess the better performance of WVD in comparison with STFT, for transient detection [10], [11].

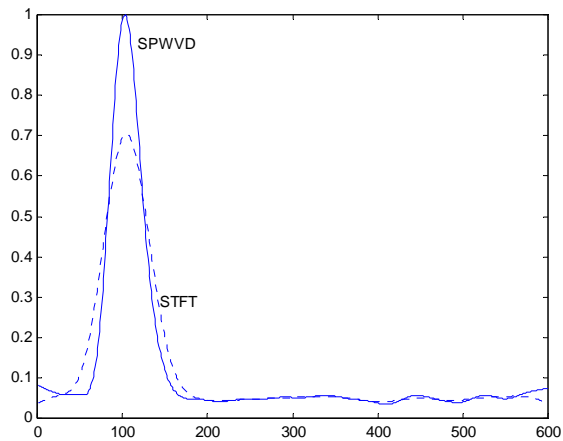

Fig. 6 Time marginal for WVD and STFT for transient signal

#### V. CONCLUSION

From the above results it is clear that, the use of WVD gives a lot of improvement in the detection and analysis of both linear as well as non-linear, non-stationary signals. So this finds lots of applications in the speech signal analysis and fault recognition systems.

As mentioned before, the main deficiency of the Wigner-Ville distribution, the so-called cross-terms need to be removed from the resultant TFR, to attain a good performance in cases of multi-component signals. There are already many methods proposed to reduce the cross terms.

Most of the methods are very specific to a particular class of signals. So there is still a need of developing improved methods for cross-term reduction. So, this is one of the possible future works in this area.

#### ACKNOWLEDGMENT

The authors gratefully acknowledge the contributions of Prof. Dr. Mohanan of Cochin University of Science and Technology for his help and support for successful completion of this research paper.

#### REFERENCES

- [1] Roberto Celi, "Time-Frequency analysis of helicopter noise" Alfred Gessow Rotorcraft Center, Department of Aerospace Engineering, University of Maryland, College Park, 2007
- [2] G. Faye, Boudreaux-Bartels, "Mixed Time Frequency Signal Transformations", University of Rhode Island, 1996
- [3] F. Hlawatsch, G.F Boudreaux-Bartels, "Linear and Quadratic Time Frequency Representations", 1992
- [4] Ning Ma, Didier Vray, Philippe Delachartre, GCrard Gimenez, "Time-frequency representation of multicomponent chirp signals", CREATES

- CNRS Research Unit (UMR5515), qfiliated to INSERM, INSA 502, 69621 Villeurbanne, France, 20 September 1996
- [5] Preeti Rao and Fred J. Taylor, "Detection and localization of narrow band transient signals using the Wigner distribution", Dept. of Electrical Engineering, University of Florida, J. Acoust. Soc. Am. Volume 90, Issue 3, pp. 1423-1434, 1991
- [6] Guillermo G. Gaunard, "Applications of (Wigner-Type) Time-Frequency Distributions to Sonar and Radar Signal Analysis", Army Research Laboratory, Adelphi, Hans C. Strifors, Defense Research Agency (FOI), Sweden, 2003
- [7] Xue W and Sun X.W, "Multiple targets detection method based on binary hough transform and adaptive time-frequency filtering", Progress In Electromagnetics Research, PIER 74, 309-317, 2007
- [8] Hu Guangshu, "Dsp-theory, algorithm and implementation," Tsinghua publishing house, 1997
- [9] Luo zhuanyi, Cheng guifen, "Random signal process and controlling foundation," Chemistry industry publishing house, 2002
- [10] "Analyse methods for audio signal detected from water leakage spot", Yang Lijian, Fang Yuchang, and Gao Songwei, Shenyang University of Technology, Shenyang, China, 2011
- [11] I. Iancu, G. Canureci, E.Iancu, M. Vinatoru, "Spectral Analysis of the Heart Sounds for Medical Diagnosis", Department of Physiology, Medical Informatics and Biostatistics, University of Medicine and Pharmacy of Craiova, Craiova, Romania, 2008
- [12] Robert A Stepien, "New method for analysis of nonstationary signals", Nonlinear Biomedical Physics, <http://www.nonlinearbiomedphys.com>, 2011
- [13] P. Bonato, Z. Erim, J. A. Gonzalez Cueto, "Decomposition of superimposed waveforms using the cross time frequency transform ", Neuro-Muscular Research Center, Boston University, Boston, MA USA, 2000
- [14] S. Femmam, "Failures detection and estimation of non-stationary signals by time-scale frequency techniques", American Journal of Scientific and Industrial Research, 2010