

# Motion Protection System Design for a Parallel Motion Platform

Dongsu Wu, Hongbin Gu

**Abstract**—A motion protection system is designed for a parallel motion platform with subsided cabin. Due to its complex structure, parallel mechanism is easy to encounter interference problems including link length limits, joints limits and self-collision. Thus a virtual spring algorithm in operational space is developed for the motion protection system to avoid potential damages caused by interference. Simulation results show that the proposed motion protection system can effectively eliminate interference problems and ensure safety of the whole motion platform.

**Keywords**— Motion protection, motion platform, parallel mechanism, Stewart platform, collision avoidance.

## I. INTRODUCTION

AS an important element of a flight simulator, the motion platform serves to simulate the motion of aircraft and provide the pilot with realistic vestibular feelings and a part of tactile feelings. According to the FAA regulations, any device called “flight simulator” must have at least one motion system, otherwise it can only be termed a “flight training device” [1]. Recently our laboratory builds a novel low cost flight simulator with a parallel motion platform. In order to reduce the overall height of the flight simulator, the parallel platform adopts a new design scheme different from conventional Stewart platform based scheme. The cabin, which holds all the simulation devices and trainees, is placed underneath the movable platform while generally the cabin is designed to stand on the movable platform. The novel low profile motion platform can be easily deposed in the normal office buildings. And due to its lower gravity center, the operation of motion platform is safer. But the subsided cabin of the platform brings another problem that the cabin may interfere with links during operation.

Actually interference is a common but serious problem for parallel mechanism. Compared to serial mechanism, parallel mechanism has relatively smaller workspace and is easier to encounter various interference problems such as geometric constraints, self collisions and collisions with outside obstacles. In order to protect structure from damage made by interference, it is necessary to design an effective motion protection system with functions of damping and limiting.

Dongsu Wu is with College of Civil Aviation, Nanjing University of Aeronautics and Astronautics, 210016, China (e-mail: tissle@nuaa.edu.cn).

Hongbin Gu is with College of Civil Aviation, Nanjing University of Aeronautics and Astronautics, 210016, China



Fig. 1 The parallel motion platform with subsided cabin

The research of motion protection for serial mechanism is mature and generally redundant techniques [2-4] are used to solve collision and interference problems. Comparatively there are fewer research results on motion protection for parallel mechanism due to its highly complex structure. UTIAS [5] proposed a link length limiting algorithm. The main idea is computing the start point for link limiting with link's maximal deceleration and dividing link's whole travel length into normal region and limiting region. As soon as any link of platform enters the limiting region, the protection command will be executed instead of the normal motion control command and the link will be pushed back to normal region. McFarland [6] from NASA presented a similar limiting algorithm. He used two order filters to generate protection command and made the limiting process smoother. Telban [7] and etc. designed a protection system for NASA's VMS flight simulator. Rubio [8] and etc. proposed a limiting algorithm in the joint space by introducing a concept of virtual spring. Only link length limit condition was considered in the algorithm. Zhou [9] and Fang [10] designed a motion protection algorithm by proposing a concept of constrained variables. And there are some protection systems using redundant design [11] similar with serial mechanism. Almost all the above algorithms are operated in the joint space. They can not be applied in our low profile motion platform directly because the interference problem between the subsided cabin and links happens in the operational space.

This paper will first analyze several interference conditions of our low profile parallel motion platform, and next describe the structure of the motion protection system. Then the original virtual spring algorithm for link length limiting is introduced.

Finally our proposed motion protection algorithm with operational space virtual spring is presented.

## II. INTERFERENCE TYPES OF THE PARALLEL PLATFORM

The parallel motion platform may encounter various types of interference problems which can be summarized as following:

### A. A link reaches its maximum or minimum stroke

The stroke limit is a basic constraint for parallel platform. The length of ball screw mounted in our motion platform is about 1.2m and two protect regions are reserved at the both ends of the ball screw.

### B. A joint reaches its mechanical limit

The proposed parallel platform is based on a 6-3 type Stewart platform. The static platform is connected to six links with six universal joints, which are specially considered during designing process. Through offline checks, these joints will never reach their mechanical limits. The movable platform is connected to six links with three patented compound ball joints which has advantages of simple structure, easy to install and large bearing capacity compared to traditional ball joints. The structure of compound ball joint is showed in fig.2.

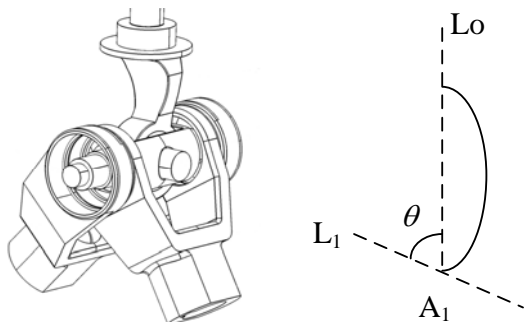

Fig. 2 Structure of the compound ball joint

The compound ball joint has three freedoms. After some offline checks, we find that mechanical limit problem may happen in the only one of the three freedoms, which is showed as angle  $\theta$  in fig. 2. When the upper platform moves, the supporting axis of the ball screw is parallel to the vertical axis  $O_A O'$  of the movable platform. So the angle  $\theta$  between  $L_o$  and  $L_1$  can be computed by the following equation

$$\theta = \cos^{-1} \frac{O_A O' \cdot n_{0,1}}{|O_A O'| |n_{0,1}|}, \quad (1)$$

where  $n_{0,1}$  is the normal vector of the plane that  $L_o$  and  $L_1$  determines,  $n_{0,1} = \frac{l_0 \times l_1}{l_0 \cdot l_1}$ . There is a limiting area  $[\theta_{\min}, \theta_{\max}]$  between supporting axis and ball joint axis. So the constraint check is based on  $\theta_{\min} \leq \theta \leq \theta_{\max}$ .

### C. Two links collide

When the movable platform has rotary motion, links may

collide with each other. The traditional way to solve this problem is to compute the distance between two links' centerlines and compare them with the sum of two links' diameters. If the distance is less than the sum, we can judge that collision has happened. The specific algorithm can refer to [12]. About our parallel platform, this collision problem has been checked during the design process and link stroke limits will happen before the condition of links' collision with each other happens. So this paper will not consider this kind of interference problem.

### D. The subsided cabin collide with a link

The subsided cabin collision with a link is a special problem which only happened in our low-profile parallel motion platform. In order to simplify this problem, we use a cylinder with limited length (fig.3) to hold the subsided cabin so that the cabin can be equivalent to a link. The distance between the cabin and a link can be computed using the same algorithm for computing the distance between links.

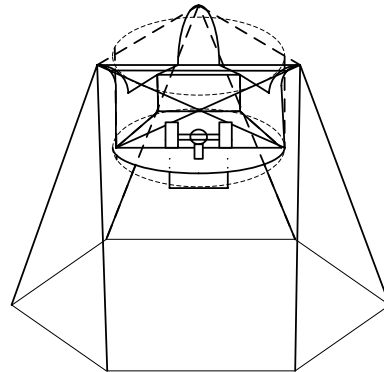

Fig. 3 Using a cylinder to hold the subsided cabin

## III. STRUCTURE OF THE MOTION PROTECTION SYSTEM

Motion platform is a complex system consisted of software and hardware. As an important element of human-in-loop simulation equipment, the motion platform needs to ensure safety at any circumstances. During installation, operation and maintenance, any mechanical, electrical failures or illegal actions may lead to damage of motion platform structure, even lead to serious accident. And those interference problems we discussed above may also affect the trainees' feeling and cause interruption of the simulation. So an effective motion protection system is needed to avoid unexpected safety problem.

Generally the motion protection system can be divided into damping subsystem and limiting subsystem. Damping subsystem is in operation to decelerate the platform motion when potential interference problem is going to happen. This subsystem is always realized by software and its design philosophy is the tradeoff between safety and simulation fidelity. When safety is more important, then simulation fidelity may be sacrificed and vice versa. Limiting subsystem is in operation to stop motion of the platform when interference problems happen or serious system failures such as unexpected

power-fails occur. Limiting functions can be realized by sophisticated designed software, electrical circuits and mechanical structures. In this paper, only software algorithms for damping and limiting are discussed.

#### IV. ORIGINAL VIRTUAL SPRING ALGORITHM

The original virtual spring algorithm was proposed to prevent a link from reaching its maximum or minimum stroke [8]. Fig. 4 shows the way virtual springs work. At the end of each link of the platform a virtual spring is attached. If the length of the link is greater (smaller) than the maximum (minimum) allowable length, this spring exerts a force that tends to move the platform away from the actuator limits.

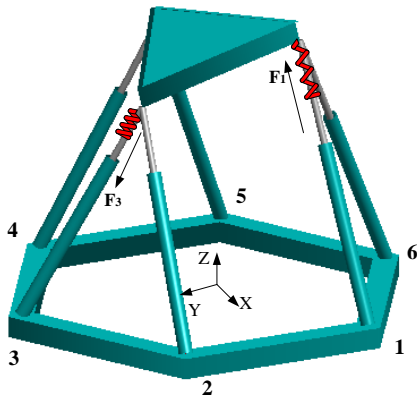

Fig. 4 Virtual spring placed at the end of each link

The spring force can be express as the following equation:

$$F_i = \begin{cases} K(l_{\max} - l_i) & \text{if } l_i > l_{\max} \\ K(l_{\min} - l_i) & \text{if } l_i < l_{\min} \\ 0 & \text{if } l_{\min} \leq l_i \leq l_{\max} \end{cases} \quad (2)$$

where  $F_i$  is driving force of the  $i$  th link,  $K$  stiffness of springs,  $l_i$  link length of the  $i$  th link,  $l_{\max}$  ( $l_{\min}$ ) is the maximum (minimum) allowable length of links.

In order to apply  $F_i$  to platform, we need merge the virtual spring algorithm into the motion control system of the platform. The dynamic model of the parallel motion platform expressed in the Newton-Euler equation [13] is

$$\mathbf{M}(\mathbf{X})\ddot{\mathbf{X}} + \mathbf{H}(\mathbf{X}, \dot{\mathbf{X}}) = \mathbf{F}_p = \mathbf{J}^T \mathbf{F}_l \quad (3)$$

where  $\mathbf{X}$ ,  $\dot{\mathbf{X}}$ ,  $\ddot{\mathbf{X}}$  separately correspond to position, velocity and acceleration information of the payload platform in task space;  $\mathbf{M}(\mathbf{X})$  is the inertia matrix;  $\mathbf{H}(\mathbf{X}, \dot{\mathbf{X}})$  the nonlinearity including Coriolis, centrifugal and gravity force;  $\mathbf{F}_p$  the driving force exerted on the platform;  $\mathbf{F}_l$  the driving force exerted on the links;  $\mathbf{J}$  the Jacobian matrix. The closed-loop controller can be built either on joint space or on operational space. We assume a joint space controller is used, and then

$$\mathbf{F}_l = \mathbf{F}_{lc} + \mathbf{F}_{lsp} \quad (4)$$

where  $\mathbf{F}_{lc}$  is the controller's output force vector,  $\mathbf{F}_{lsp}$  is the

virtual springs' force vector.

#### V. MOTION PROTECTION ALGORITHM WITH VIRTUAL SPRING IN OPERATIONAL SPACE

In this section, virtual spring algorithm is extended to operational space. We assume that the surfaces of all links and the cabin are covered with a layer of virtual spring. As soon as the distance between the cabin and a link is close enough, virtual spring force will exert on the subsided cabin. That will slow down the motion of the movable platform and then protect the moving parts from collision. The motion protection algorithm is based on this idea.

The parameters used in this algorithm are virtual spring's travel length  $d$  and stiffness  $K$ . The principle of virtual spring in operational space is showed in fig.5.

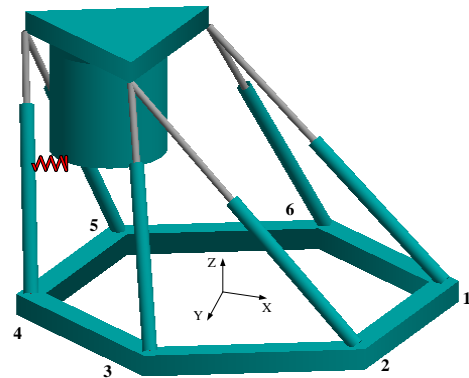

Fig. 5 Virtual spring in operational space

To verify the effectiveness of the proposed algorithm, numerical simulation is conducted here. From fig.5, we can see that the 2<sup>nd</sup>, 3<sup>rd</sup>, and 4<sup>th</sup> link is symmetrical with 1<sup>st</sup>, 6<sup>th</sup> and 5<sup>th</sup> link relative to X axis. During the simulation, the movable platform will move along negative direction of X axis. When a certain distance is travelled, the cabin will be close to 4<sup>th</sup> and 5<sup>th</sup> link and enter the damping region due to the existence of virtual springs.  $d$  is chosen as 0.2m and  $K$  is 50000 here. Because both the cabin and links are simplified as cylinders, the direct of the virtual force will be along the vector of shortest distance between cabin and link. The virtual spring force can be expressed as:

$$FS_i = \begin{cases} K d_i & \text{if } d_i > 0 \\ 0 & \text{if } d_i = 0 \end{cases} \quad (5)$$

where  $d_i$  is the compressing length of virtual spring attached on the  $i$  th link,  $FS_i$  is the virtual force that the  $i$  th link exerts to the cabin. Because the working point does not coincide with the gravity center of the movable platform, the composite virtual spring force generates an external force and an external moment for the movable platform.

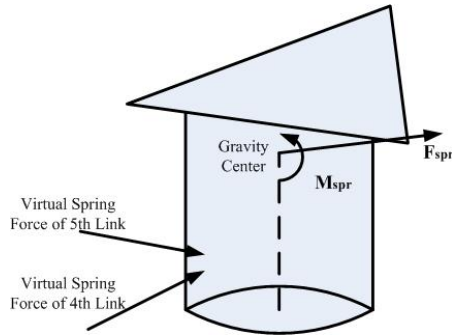

Fig. 6 Virtual spring force exerted on the movable platform

So the dynamic model can be rewritten as follows,

$$M(X)\ddot{X} + H(X, \dot{X}) = \begin{Bmatrix} F_{ctrl} + F_{spr} \\ M_{ctrl} + M_{spr} \end{Bmatrix} = J^T F_l \quad (6)$$

where  $F_{ctrl}$  and  $M_{ctrl}$  are control force and moment of operational space controller,  $F_{spr}$  and  $M_{spr}$  are force and moment that virtual springs exert. The motion trajectories of movable platform and virtual forces in the operational space are shown in the following figures.

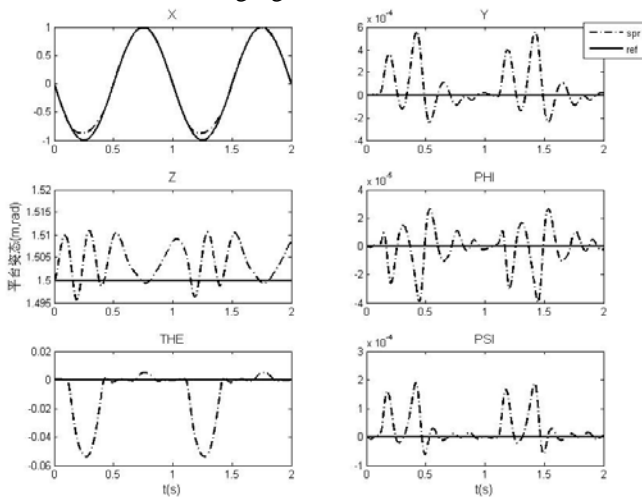

Fig. 7 Position and attitude of the movable platform during simulation

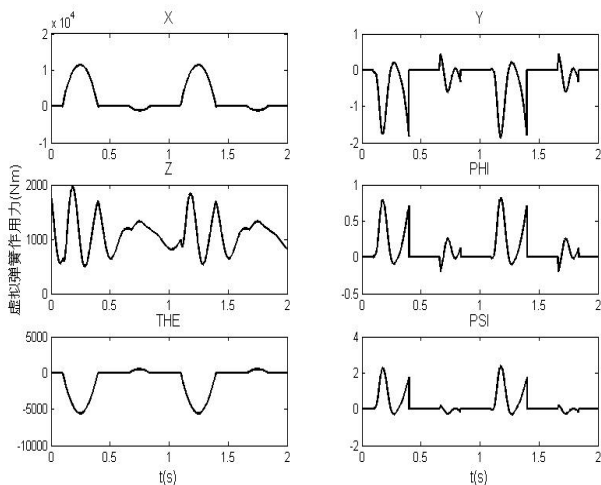

Fig. 8 Virtual spring force and moment in operational space

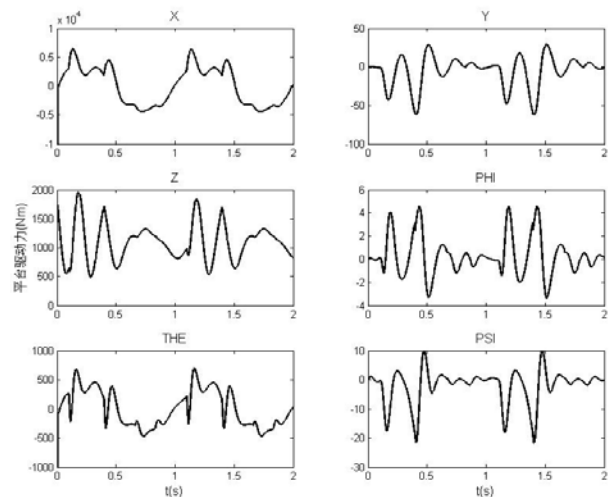

Fig. 9 Driving force and moment in operational space

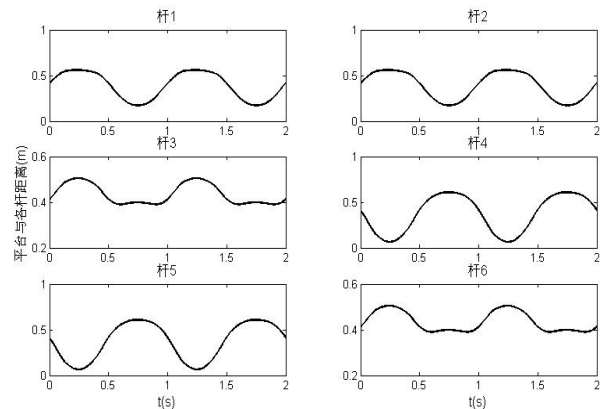

Fig. 10 The shortest distances between each link and cabin

From the above figures, we can see that during the simulation process the subsided cabin will collide with the 4th and 5th link if virtual springs are not added. With the help of virtual springs, the motion of movable platform becomes smooth and gentle when the platform is close enough to any link. Simulation results show that the proposed motion protection algorithm can effectively avoid damages caused by interference problems in operational space. Virtual springs on the operational space can also be added on the compound ball joints to avoid reaching its mechanical limits.

## VI. CONCLUSION

In this paper a motion protection system is designed for a parallel motion platform. First we analyze various types of interference problems which may be encountered in operation space including link length limits, joints limits and self-collision problems. Then we describe the structure of the motion protection system. And next the original virtual spring algorithm for link length limits is introduced. Considering this algorithm can not be used directly for any other interference problems, we develop a novel virtual spring algorithm in operational space instead. Numerical simulation results show that the proposed motion protection system can effectively

eliminate interference problems and ensure safety of the whole motion platform.

#### REFERENCES

- [1] B. C. Judith, N. S. Nancy and L. Thomas, "Simulator platform motion - the need revisited," *The International Journal of Aviation Psychology*, vol. 8, no. 3, pp. 293-317, 1998.
- [2] C. H. Francois and M. Eric, "A new redundancy-based iterative scheme for avoiding joint limits application to visual servoing," *Proceedings of IEEE International Conference on Robotics & Automation*, pp.1720-1725, 2000.
- [3] F. C. Tan and V. Rajiv, "A weighted least-norm solution based scheme for avoiding joint limits for redundant joint manipulators," *IEEE Transaction on Robotics & Automation*, vol. 11, no. 2, pp.286-292, 1999.
- [4] K. Tchnon and A. Matszok, "On avoiding singularity in redundant robot kinematics," *Robotica*, vol. 13, pp.599-606, 1995.
- [5] L. D. Reid and M. A. Nahon, "Flight simulator motion-based drive algorithm: part 2 - selecting the system parameters", *UTIAS Report No.307*, 1986.
- [6] R. E. McFarland, "Adjusting limiting algorithms for robust motion simulation," *AIAA Modeling and Simulation Technologies Conference*, 2001.
- [7] R. J. Telban, F. M. Cardullo and L. C. Kelly, "Motion cueing algorithm development: new motion cueing program implementation and tuning", *NASA CR-2005-213746*, 2005.
- [8] A. Rubio, A. Avello and J. Florez, "On the use of virtual springs to avoid singularities and workspace boundaries in force-feedback teleoperation", *Proceedings of the 2000 IEEE International Conference on Robotics & Automation*, pp.2690-2695, 2000.
- [9] B. Zhou, *Study on the Disgn and Interference-Safeguard Problem of the Stewart Platform Parallel Manipulator*, Xi'an Jiaotong University, China, PHD Thesis, 2002.
- [10] H. Fang, *The Research on Safety Mechanism Design and Control Methods of 6-Dof Parallel Manipulators*, Xi'an Jiaotong University, China, PHD Thesis, 2002.
- [11] I. Chunkpaiwong and W. S. Newman, "Reflexive collision avoidance for a novel parallel manipulator" *Proceedings of the 2001 IEEE/RSJ International Conference on Intelligent Robots and Systems*, pp.1293-1298, 2001.
- [12] J. P. Merlet and D. Daney, "Legs interference checking of parallel robots over a given workspace or trajectory" *Proceedings of 2006 IEEE International Conference on Robotics and Automation*, pp.757-762, 2006.
- [13] B. Dasgupta, T. S. Mruthyunjaya, "Closed-form dynamic equations of the general Stewart platform through the Newton-Euler approach," *Mechanism and Machine Theory*, vol. 33, no. 7, pp. 993-1012, 1998.