

# Tensile Properties of 3D Printed PLA under Unidirectional and Bidirectional Raster Angle: A Comparative Study

Shilpesh R. Rajpurohit, Harshit K. Dave

**Abstract**—Fused deposition modeling (FDM) gains popularity in recent times, due to its capability to create prototype as well as functional end use product directly from CAD file. Parts fabricated using FDM process have mechanical properties comparable with those of injection-molded parts. However, performance of the FDM part is severally affected by the poor mechanical properties of the part due to nature of layered structure of printed part. Mechanical properties of the part can be improved by proper selection of process variables. In the present study, a comparative study between unidirectional and bidirectional raster angle has been carried out at a combination of different layer height and raster width. Unidirectional raster angle varied at five different levels, and bidirectional raster angle has been varied at three different levels. Fabrication of tensile specimen and tensile testing of specimen has been conducted according to ASTM D638 standard. From the results, it can be observed that higher tensile strength has been obtained at 0° raster angle followed by 45°/45° raster angle, while lower tensile strength has been obtained at 90° raster angle. Analysis of fractured surface revealed that failure takes place along with raster deposition direction for unidirectional and zigzag failure can be observed for bidirectional raster angle.

**Keywords**—Additive manufacturing, fused deposition modeling, raster angle, tensile strength.

## I. INTRODUCTION

THE term Additive Manufacturing (AM) is defined by ASTM F42 committee as “Process of joining materials to make 3D object from 3D model data, usually layer upon layer, as opposed to subtractive manufacturing methodologies such as traditional machining” [1]. The term AM consists of variety of processes such as Selective Laser Sintering (SLS), Selective Laser Melting (SLM), Direct Laser Metal Sintering (DMLS), Stereolithography (SLA), Electron Beam Melting (EBM), Ultrasonic Additive Manufacturing (UAM), FDM and so on. FDM is one of the most widely used AM techniques to fabricate polymer component. In FDM, thermoplastic polymer is used as feedstock filament that heated above the glass transition temperature in the heated nozzle and then semi solid filament extruded through nozzle and deposited on the previously deposited layer as CAD defined geometry [2], [3].

FDM printed parts have numerous applications in the field of automobile, aviation, medical and consumer part industries

Shilpesh R. Rajpurohit is with the Sardar Vallabhbhai National Institute of Technology, Surat - 395 007 India (e-mail: shilpesh18@gmail.com).

Harshit K. Dave is with the Sardar Vallabhbhai National Institute of Technology, Surat - 395 007, India (corresponding author, e-mail: harshitkumar@yahoo.com).

and so on. However, the mechanical properties of FDM part are relatively poor than those with injection molded part. With the growing application of FDM part as functional part, mechanical properties of the FDM part are of research interest.

Durugan and Ertan [4] observed that specimen build with 0° raster angle in horizontal plane exhibited optimal mechanical properties. Bagsik et al. [5] investigated the effect of raster angle and build direction on tensile properties of polyetherimide part. They stated that part fabricated with X direction possesses higher tensile strength followed by y direction and lowest strength obtained with z direction. Garg et al. [6] investigated the effect of part orientation and raster angle on tensile and flexural strength of ABS part. They observed that higher tensile and flexural strength has been obtained along with X and Y directions. Mishra et al. [7] suggested that higher number of perimeter increases the flexural strength. Qattawi et al. [8] suggested higher extrusion temperature and larger layer height improves the mechanical properties. Dawoud et al. [9] studied the effect of air gap on mechanical properties of 3D printed ABS having crisscross structure. Motapatri et al. [10] investigated the effect of process parameter on flexural properties of Ultem 9085 part. They found that vertically build specimen possesses higher flexural strength and negative air gap improves the flexural strength. Wang and Gardner [11] investigated the influence of layer height and bed temperature on the impact strength of the FDM printed PLA. They observed higher impact strength than injection molded part at lower layer height and higher bed temperature. Lanzotti et al. [12] investigated the tensile properties of the PLA material fabricated through open source 3D printer. They observed that higher tensile strength has been observed at lower infill orientation and higher number of perimeter. From their experimental study, Sood et al. [13] observed that higher number of layers, smaller raster angle and negative air gap improves the mechanical properties of the 3D printed part. Song et al. [14] studied the anisotropy in mechanical properties of PLA part. They concluded that porosity in the part could be minimized by optimizing the extrusion temperature and speed of extrusion along with speed of deposition. Liu et al. [15] used gray Taguchi method to optimize the mechanical properties. They studied the effect of raster orientation, layer thickness, infill style, raster width and raster gap on tensile, flexural and impact strength of part. Riddick et al. [16] found that vertically build part has lower tensile properties.

Majority of the previous research studies focus on the effect

of the unidirectional raster angle on the mechanical properties of the FDM part. Relatively very less work has been reported with effect of bidirectional raster angle on tensile properties of FDM part. To the best of authors' knowledge, a comparative study on effect of unidirectional and bidirectional raster angle on tensile strength has not been previously reported. Hence, there is a requirement of a comparative study between unidirectional and bidirectional raster angle on tensile properties of printed part.

In the present study, effect of unidirectional and bidirectional raster angle has been carried out on tensile strength of printed part. To this end, tensile specimen has been fabricated and FDM printed by selecting unidirectional and bidirectional raster angle, layer height and raster width as process parameters. The effect of process parameters on fractured surface has been also investigated.

## II. EXPERIMENTAL DETAILS

### A. Fabrication of Tensile Specimen

The objective of the present study was to investigate the effect of unidirectional and bidirectional raster angle on tensile strength of FDM printed polymer part. In order to do so, tensile test has been performed on specimen made of PLA as per the ASTM D638 standard. PLA is semi-crystalline and bio-friendly thermoplastic polymer, which having relatively low glass transition temperature. It is a very popular material among the 3D printing community due to its vast application and numerous advantages. PLA feedstock filament having 1.75 mm diameter has been used to fabricate tensile specimen as per ASTM D638 standard as shown in Fig. 1. All the specimens were fabricated using Omega dual extruder FDM printed with the printing condition as shown in Table I.

TABLE I  
 FDM 3D PRINTING CONDITION

Process parameter	Value
Raster angle (°) (variable)	0, 30, 45, 60, 90, 0/90, 30/60, 45/45
Layer height (µm) (variable)	100, 200, 300
Raster width (µm) (variable)	400, 500, 600, 700
Liquefier temperature (°C)	210
Bed temperature (°C)	70
No. of perimeters	1
Infill percentage (%)	100
Infill pattern	Rectilinear

In order to understand effect of unidirectional and bidirectional raster angle on tensile strength of FDM printed part, raster angle has been varied at five different levels for unidirectional raster angle and three different levels for bidirectional raster angle as shown in Table I.

In unidirectional raster angle, all the raster was deposited at a fixed angle to loading direction in all layers of the specimen. Five different levels of 0°, 30°, 45°, 60°, and 90° have been selected to fabricate the specimen. Fig. 2 shows the graphical representation for unidirectional raster angle for different levels.

In bidirectional raster angle, raster was deposited with

increment of 90° to the previously deposited layer throughout the specimen. Three different levels of 0°/90°, 30°/60° and 45°/45° have been used to fabricate the specimen. Fig. 3 shows the graphical representation for bidirectional raster angle.

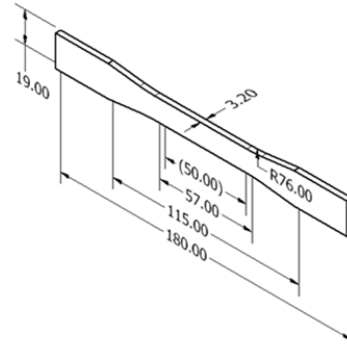

Fig. 1 Tensile specimen according to ASTM D638 standard (all dimensions are in mm)

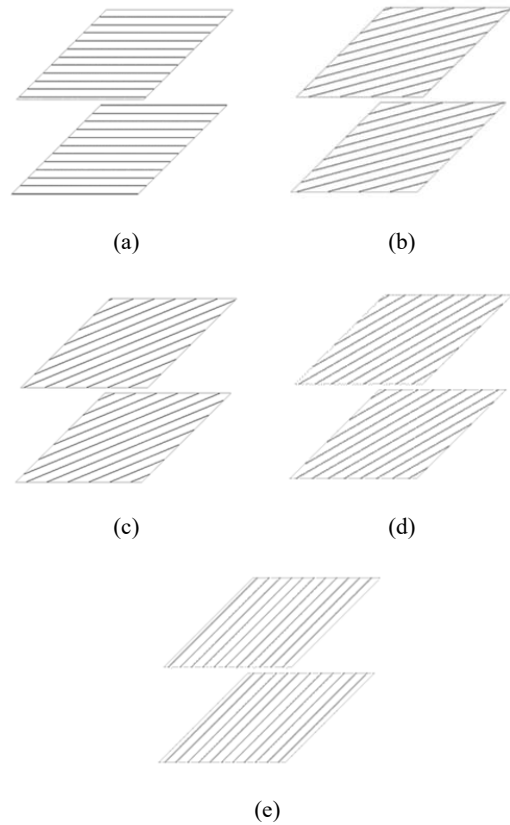

Fig. 2 Unidirectional raster angle (a) 0°, (b) 30°, (c) 45°, (d) 60° and (e) 90°

Further, layer height and raster width has been varied for both unidirectional and bidirectional raster angles as shown in Table I to understand the behavior of raster angle at different layer height and raster width. All the specimens have been fabricated twice, mean value of response has been used to plot the relation between raster angle and tensile strength.

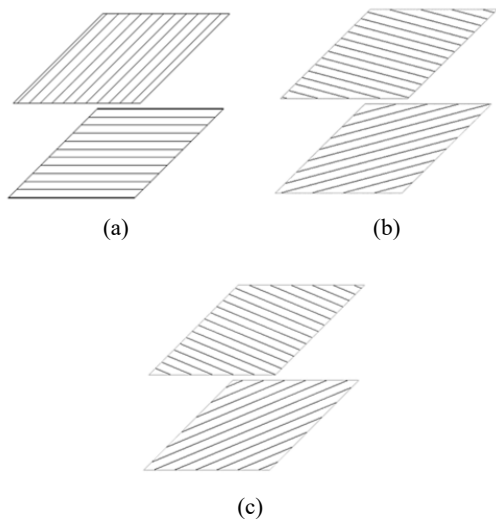

Fig. 3 Bidirectional raster angle (a) 0°/90°, (b) 30°/60° and (c) 45°/45°

### B. Tensile Testing

To investigate tensile properties, tensile test has been carried out on Tinius Olsen H50KL machine with a load cell of 50 kN capacity. The tensile test was performed at a constant speed of 5 mm/min until the specimen fractures. Test data of stress and strain were recorder through the built-in horizon software.

### III. RESULTS AND DISCUSSION

A number of experiments have been performed in order to understand the effect of unidirectional and bidirectional raster angles at different layer heights and raster widths on the tensile strength of the FDM printed PLA material. To better understand the correlation between unidirectional and bidirectional raster angle at a range of layer height and raster angle, graphical representation of the results has been provided in Figs. 4, 6 and 8.

The effect of 0°, 90° unidirectional and 0°/90° bidirectional raster angle has been shown in Fig. 4. From Fig. 4, it can be revealed that mostly higher tensile strength has been observed with 0° raster angle, while 90° raster angle resulted into lower tensile strength. For 0°/90° raster angle, tensile strength mostly fell down between those of 0° and 90° raster angle. This difference can be explained by considering raster to raster bonding and tensile strength of each individual raster. At 0° raster angle, all the rasters are deposited parallel to the loading direction. Due to parallel deposition of raster, each individual raster takes the load and effect of bonding between rasters can be minimized. The failure of the specimen can take place due to individual pulling and necking of each individual raster as a function of tensile loading. For specimen with 90° raster angle, force was exerted perpendicular to raster deposition that resulting into failure of raster to raster bonding. Since the strength of the raster to raster bonding is less than the strength of the individual raster, it results in lesser tensile strength. For specimen with 0°/90° raster angle, 0° deposited raster bars

more load as specimen is pulled under tensile load. These deposited rasters which are loaded along their length have higher strength. The strength in 90° layer depends on the bonding between adjacent rasters, which is always weaker than strength of filament.

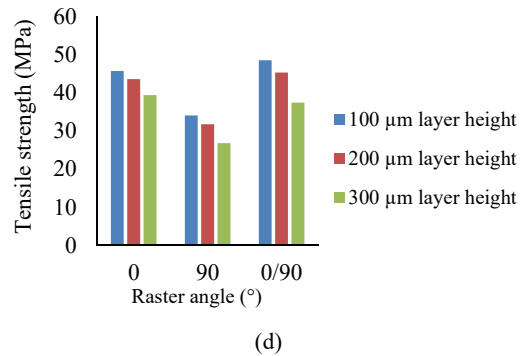
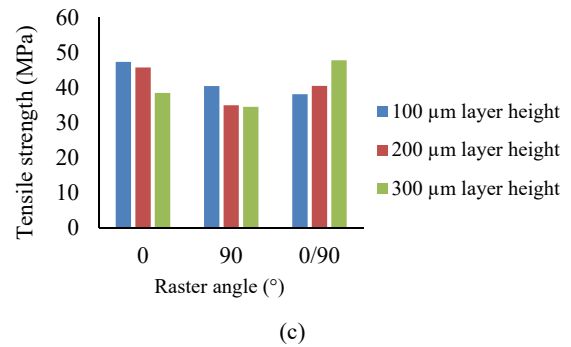
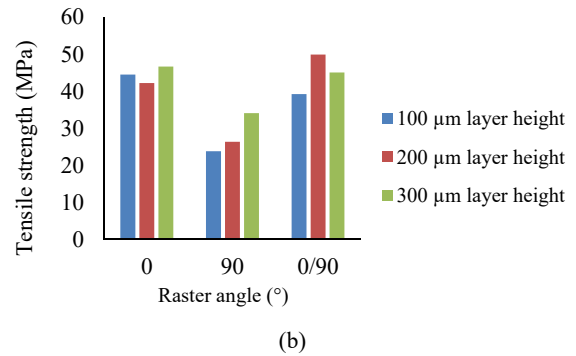
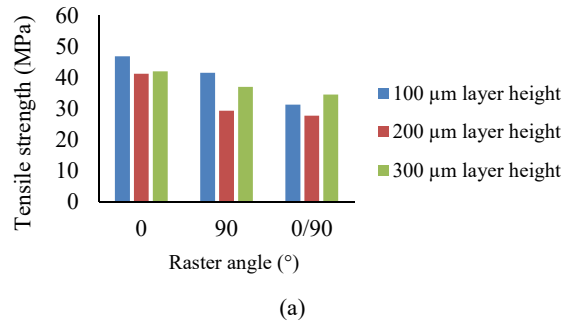

Fig. 4 Effect of 0°, 90° and 0°/90° raster angle on tensile strength at (a) 400 μm raster width, (b) 500 μm raster width, (c) 600 μm raster width and (d) 700 μm raster width

Fig. 5 shows the fractured surface of specimen at 0°, 90°, and 0°/90° raster angle. It can be seen that, at 0° raster angle, failure takes place perpendicular to raster deposition with considerable amount of ductility. Significant amount of necking can be seen with 0° raster angle. For 90° raster angle, fracture takes place perpendicular to raster deposition, and failure takes place through the bonding of rasters with brittle fracture. In 0°/90° raster angle, zigzag failure pattern has been observed. It can be seen that half of the rasters which are deposited at 0° angle have failure which takes place through individual each raster, while half of the layers that are deposited at 90° angle have failure through the raster bonding.

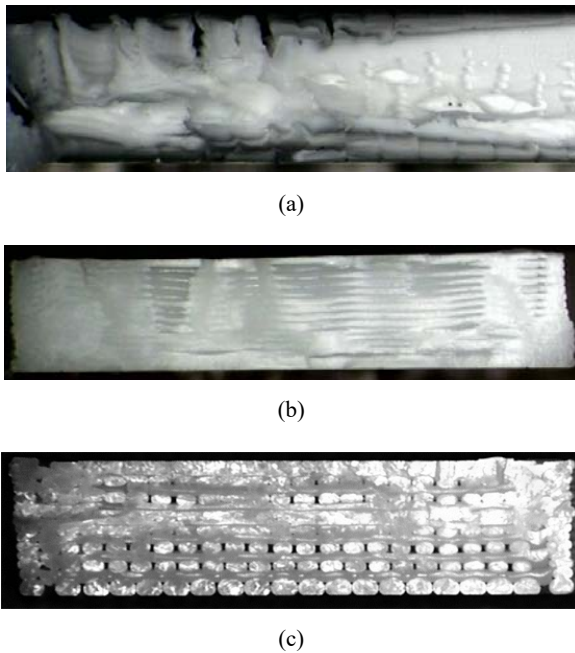
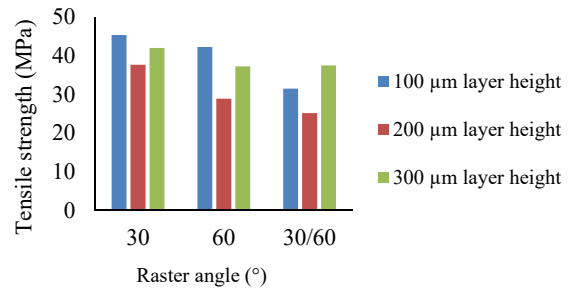

Fig. 5 Fractured surface of specimen at (a) 0°, (b) 90° and (c) 0°/90° raster angle

Fig. 6 shows the effect of 30°, 60°, and 30°/60° raster angle on tensile strength of specimen. It can be stated that mostly higher tensile strength has been observed with 30°/60° raster angle, while lower tensile strength has been observed with 30° raster angle. For 60°, tensile strength mostly fell down between those of 30°/60° and 60°.

For specimen with 30°/60°, all the raster deposited equally at 30° and 60° on one another. At 30°/60° raster angle, increased overlap region can help to improve the bonding between raster and layers that resulting into higher tensile strength. For specimen with 30° raster angle, raster deposited at 30° to the loading direction and failure takes place along with raster deposition through raster to raster bonding which have relatively weaken than individual raster. For specimen with 60° raster angle, raster deposited 60° to the loading direction, and again failure takes place along with raster deposition. The failure has taken place through the raster bonding which is relatively weaken.



(a)

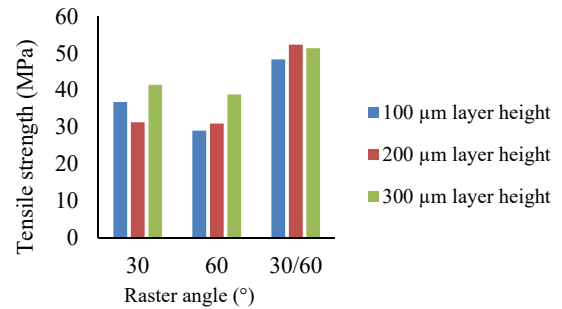

(b)

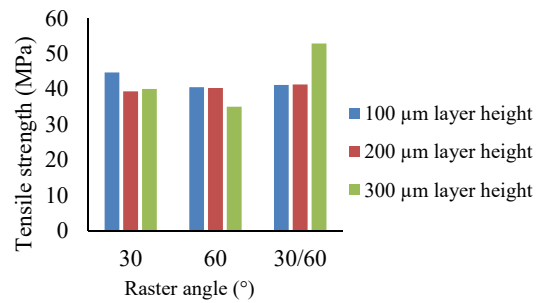

(c)

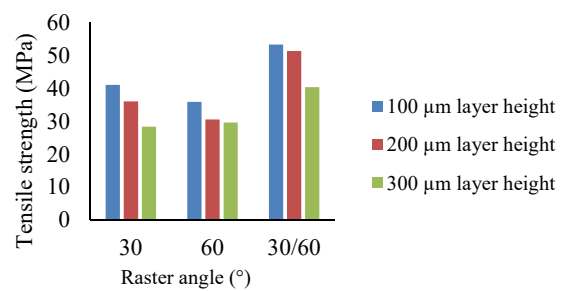

(d)

Fig. 6 Effect of 30°, 60° and 30°/60° raster angle on tensile strength at (a) 400 μm raster width, (b) 500 μm raster width, (c) 600 μm raster width and (d) 700 μm raster width

Fig. 7 shows the fractured surface of the tensile specimen at 30°, 60° and 30°/60° raster angle. It can be seen that, for unidirectional raster angle 30° and 60°, failure takes place along with raster deposition direction through bonding between adjacent rasters. For bidirectional raster angle 30°/60°, it can be seen that failure takes place perpendicular to

loading direction and zigzag mode of failure pattern can be observed.

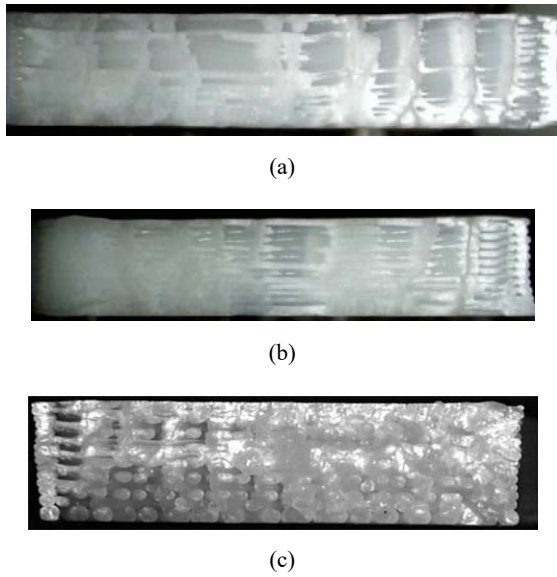

Fig. 7 Fractured surface of specimen at (a) 30°, (b) 60° and (c) 30°/60° raster angle

Fig. 8 shows the effect of 45° and 45°/45° raster angle on tensile strength of specimen. It can be seen that mostly higher tensile strength has been observed with 45°/45° raster angle, while lower tensile strength has been observed with 45° raster angle.

For specimen with 45°/45° raster angle, rasters have deposited at a 90° increment to the previous deposited layer at 45° so that crisscross structure at 45°/45° can be obtained. In 45°/45° raster angle, increased overlap region can help into improve the bonding between the raster and layer that resulting into higher strength. For specimen with 45° raster angle, raster deposited at 45° to loading direction and failure takes place along with raster deposition though bonding between adjacent raster. Bonding between rasters has relatively less strength which resulting into less strength than 45°/45° raster angle.

Fig. 9 shows the fractured surface of the tensile specimen at 45° and 45°/45° raster angle. It can be seen that for unidirectional raster angle 45°, failure takes place along with raster deposition direction at 45° through bonding between adjacent rasters. For bidirectional raster angle 45°/45°, it can be seen that failure takes place perpendicular to loading direction and zigzag mode of failure pattern can be observed.

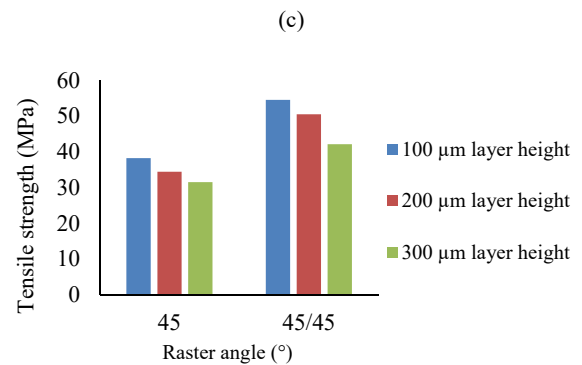
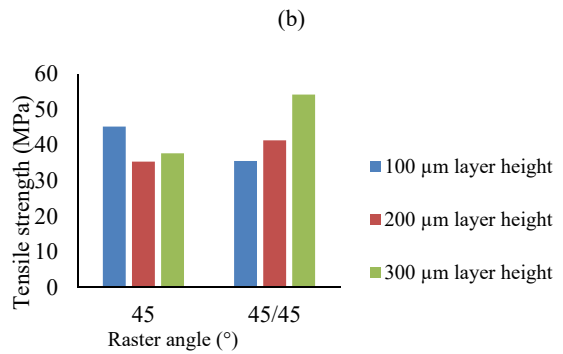
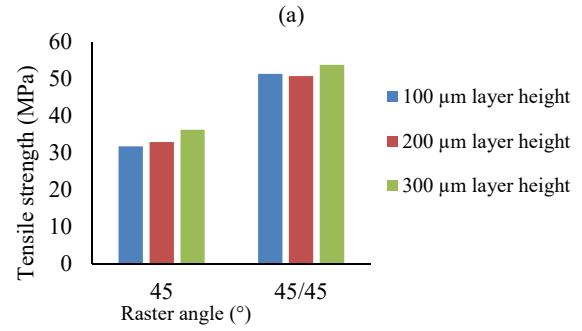
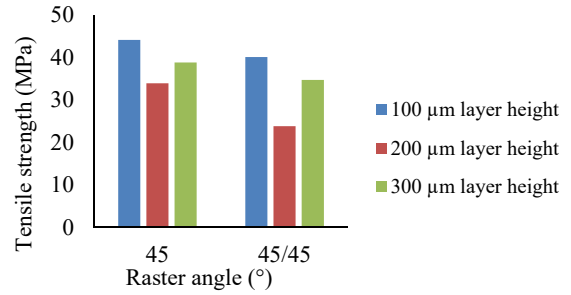
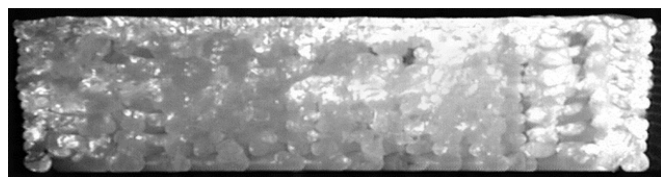

Fig. 8 Effect of 45° and 45°/45° raster angle on tensile strength at (a) 400 μm raster width, (b) 500 μm raster width, (c) 600 μm raster width and (d) 700 μm raster width



(a)



(b)

Fig. 9 Fractured surface of specimen at (a) 45° and (b) 45°/45°

#### IV. RESULTS AND DISCUSSION

In the present study, effect of unidirectional and bidirectional raster angle has been selected to study their effect on the tensile performance of 3D printed PLA part. Five different unidirectional and three bidirectional raster angles have been varied at a different combination of raster width and layer height to investigate the tensile strength. A comparative study has been made between the unidirectional and bidirectional raster angle to evaluate the tensile performance. Further, analysis of fractured surface has been carried out via microscopic examination to understand the fracture behavior of printed part. Based on the experimental investigation, the following conclusion can be drawn.

- For unidirectional raster angle, higher tensile strength has been obtained at 0° raster angle, while lower strength has been observed at 90°.
- For bidirectional raster angle, higher tensile strength has been observed at 45°/45° raster angle and lower strength observed at 0°/90°.
- In unidirectional raster angle, failure takes place along with raster deposition through raster bonding except 0° raster angle. For bidirectional raster angle, failure takes place perpendicular to loading direction and zigzag mode of failure has been observed.
- At lower raster angle, unidirectional raster angle gives the higher tensile strength. However, as the raster angle increases, higher tensile strength has been observed for bidirectional raster angle.

#### REFERENCES

[1] ASTM, A., 2012. F2792-12 Standard terminology for additive manufacturing technologies. ASTM International.

[2] C. K. Chua, K. F. Leong, 3D printing and additive manufacturing: principles and applications of rapid prototyping, World Scientific Publishing Co Inc., 2014

[3] I. Gibson, D. W. Rosen, B. Stucker, Additive manufacturing technologies, New York: Springer, 2010

[4] I. Durgun, and R. Ertan, 'Experimental investigation of FDM process for improvement of mechanical properties and production cost', Rapid Prototyping Journal, vol. 20, 2014, pp.228-235

[5] A. Bagsik, V. Schöppner, and E. Klemp, "FDM part quality manufactured with Ultem 9085," In 14th international scientific conference on polymeric materials, vol. 15, 2010, pp. 307-315.

[6] A. Garg, A. Bhattacharya and A. Batish, "On surface finish and dimensional accuracy of FDM parts after cold vapor treatment," Materials and Manufacturing Processes, vol. 31, 2016, pp.522-529.

[7] S. B. Mishra, R. Malik, and S. S. Mahapatra, "Effect of External Perimeter on Flexural Strength of FDM Build Parts," Arabian Journal for Science and Engineering, 2017 pp.1-9.

[8] A. Qattawi, B. Alrawi, and A. Guzman, "Experimental Optimization of Fused Deposition Modelling Processing Parameters: a Design-for-Manufacturing Approach," Procedia Manufacturing, vol. 10, 2017,

pp.791-803.

[9] M. Dawoud, I. Taha, and S. J. Ebeid, "Mechanical behaviour of ABS: An experimental study using FDM and injection moulding techniques," Journal of Manufacturing Processes, vol. 21, 2017, pp.39-45.

[10] K. P. Motaparti, G. Taylor, M. C. Leu, K. Chandrashekhara, J. Castle and M. Matlack, "Experimental investigation of effects of build parameters on flexural properties in fused deposition modelling parts," Virtual and Physical Prototyping, 2017, pp.1-14.

[11] L. Wang and D. J. Gardner, "Effect of fused layer modeling (FLM) processing parameters on impact strength of cellular polypropylene," Polymer, vol.113, 2017, pp.74-80.

[12] A. Lanzotti, M. Grasso, G. Staiano, and M. Martorelli, "The impact of process parameters on mechanical properties of parts fabricated in PLA with an open-source 3-D printer," Rapid Prototyping Journal, vol. 21, 2015, pp.604-617.

[13] A. K. Sood, R. K. Ohdar, and S. S. Mahapatra, "Parametric appraisal of mechanical property of fused deposition modelling processed parts," Materials & Design, vol. 31, 2015, pp.287-295.

[14] Y. Song, Y. Li, W. Song, K. Yee, K. Y. Lee, and V. L. Tagarielli, Measurements of the mechanical response of unidirectional 3D-printed PLA. Materials & Design, vol. 123, 2017 pp.154-164.

[15] X. Liu, M. Zhang, S. Li, L. Si, J. Peng, and Y. Hu, "Mechanical property parametric appraisal of fused deposition modeling parts based on the gray Taguchi method," The International Journal of Advanced Manufacturing Technology, vol. 89, 2017, pp. 2387-2397

[16] J. C. Riddick, M. A. Haile, R. Von Wahle, D. P. Cole, O. Bamiduro and T. E. Johnson, "Fractographic analysis of tensile failure of acrylonitrile-butadiene-styrene fabricated by fused deposition modeling" Additive Manufacturing, vol. 11, 2016, pp. 49-59.