

# Simple Broadband Gysel Combiner with a Single Coupled Line

Ali Darwish<sup>1</sup>, Kenneth McKnight<sup>1</sup>, Mona Zaghoul<sup>2</sup>, Edward Viveiros<sup>1</sup>, and H. Alfred Hung<sup>1</sup>

<sup>1</sup>Army Research Laboratory, Adelphi, MD 20783

<sup>2</sup>George Washington University, Washington, DC, 20052

**Abstract** — A coupled-Gysel broadband combiner/divider is proposed and demonstrated. The new concept relies on using a single coupled line segment in the design. Significant improvement in bandwidth are realized while maintaining low-loss, ease of design, and flexibility. The coupled-Gysel is demonstrated with a 2.5 – 8 GHz (105% fractional bandwidth) divider with 0.1 dB divider loss, and a 3.4 – 10.2 GHz (100% fractional bandwidth) with 0.2 dB divider loss.

## I. INTRODUCTION

The Wilkinson divider is one of the most commonly used power dividers [1] because of its simplicity, and size. It has also been researched extensively. One of the main limitations of the Wilkinson divider stems from the isolation resistor. It poses two problems. First, it is assumed to have zero or very small electrical delay. Second, it joins the two signal branches and does not go to ground. The requirement of having a very small electrical length is difficult to satisfy, especially, for discrete resistors (such as surface mount resistors). Even for MMICs, satisfying this requirement means the two signal branches need to be brought in close proximity (which introduces coupling) and using a resistor with small physical dimensions. Reducing the resistor's physical dimension reduces its power handling capability. Additionally, the fact that it is not grounded makes it difficult to dissipate the heat. The Gysel divider/combiner [2] solves both problems and can be used for combining high power signals. Many improvements on the original concepts were introduced. For example, operating the Gysel with equal/unequal power division and arbitrary terminal impedances has been shown [3]-[4]. Additionally, dual-frequency operation has been demonstrated [5].

Coupled lines have been used with Wilkinson dividers [6] to extend the bandwidth. They have also been used with Gysel dividers [7] to introduce signal filtering or dual band operation [8]. Other novel dividers have also been introduced to accomplish broadband division [9]-[10]. The use of coupled lines gives flexibility. However, the added complexity may lead to greater losses in the divider and complicate the design process as the circuit acquires more poles and zeros. Thus, it is desirable to maintain the simplicity of the original Gysel structure (with its low loss, due to low impedance, lines) while introducing the minimum number of coupled lines.

This paper presents a coupled-Gysel which utilizes a single coupled-line to significantly extend the bandwidth without increasing the insertion loss. Simulations and measurements

are presented for two cases: a 2.5 – 8 GHz (105% fractional bandwidth) divider with 0.1 dB loss, and a 3.4 – 10.2 GHz

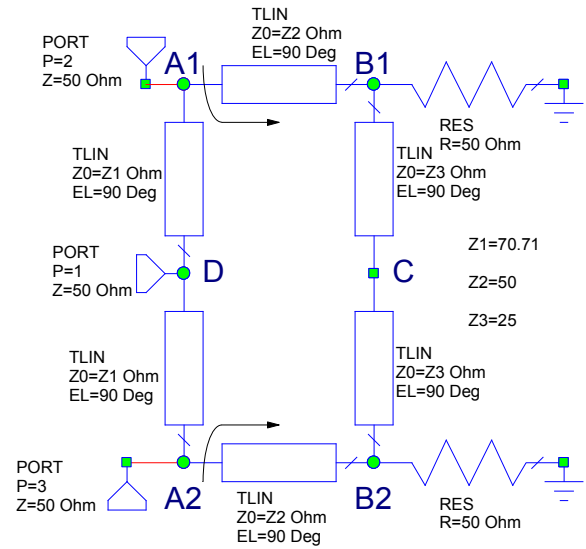

Fig. 1a. Schematic of a Gysel divider.

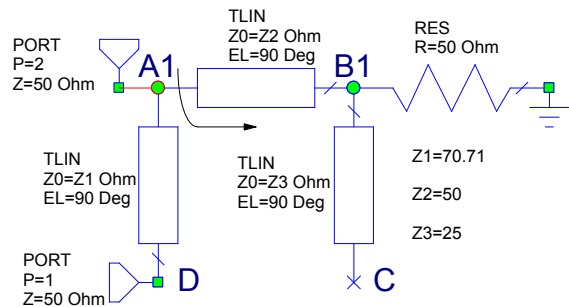

Fig. 1b. Even mode equivalent circuit of Gysel divider.

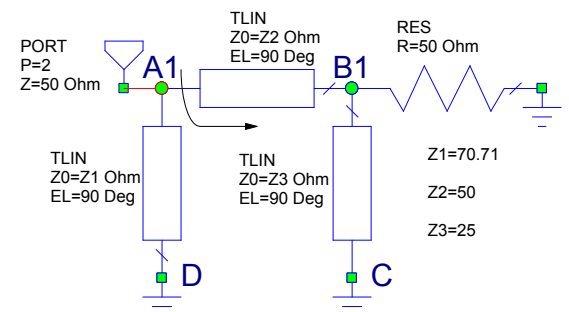

Fig. 1c. Odd mode equivalent circuit of Gysel divider.

(100% fractional bandwidth) divider with 0.2 dB loss. This is one of the largest bandwidth demonstrated for a Gysel power divider. This bandwidth is accomplished while maintaining low RF loss and design simplicity.

## II. COUPLED-GYSEL DIVIDER/COMBINER

The schematic of a classical Gysel divider is shown in Fig. 1a, the even mode equivalent circuit is shown in Fig. 1b, and the odd mode is shown in Fig. 1c. The operation of the Gysel, Fig. 1a, is similar to the Wilkinson divider. From port 1, the signal divides equally (due to symmetry) forming an even mode which travels towards ports 2 and 3. The  $\lambda/4$  Z1-line transforms the impedances of ports 2, and 3 from 50  $\Omega$  to 100  $\Omega$  to obtain a good match at port 1. Additionally, the even mode

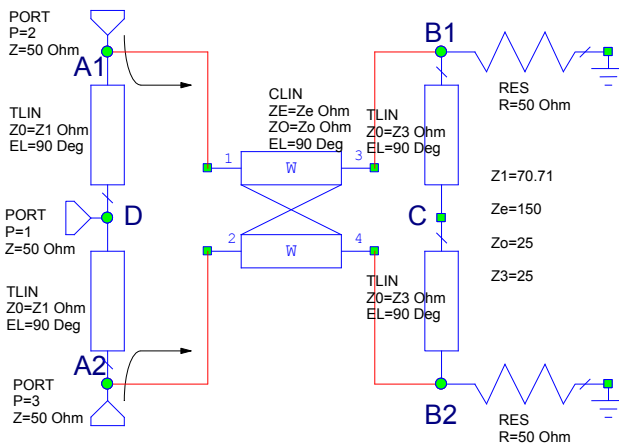

Fig. 2a. Schematic of proposed coupled-Gysel divider.

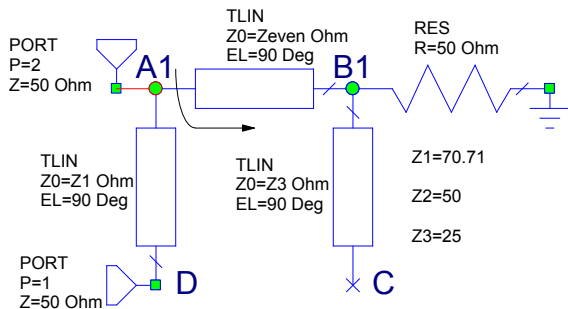

Fig. 2b. Even mode equivalent circuit of coupled-Gysel divider.

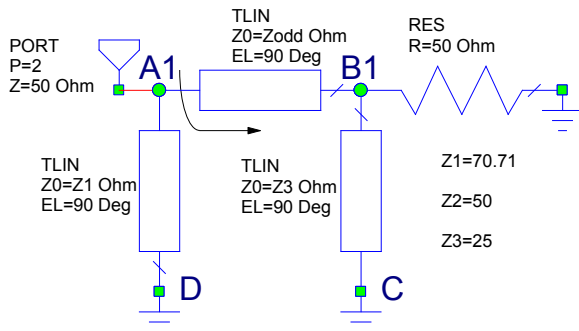

Fig. 2c. Odd mode equivalent circuit of coupled-Gysel divider.

sees a virtual open circuit at C which is transformed by the  $\lambda/4$  Z3-line into a short circuit at B1 and B2. This, in turn, gets

transformed by the  $\lambda/4$  Z2-line into an open circuit at A1 and A2. Hence, the even mode, at ports 2, and 3, sees a 50  $\Omega$  port impedance in parallel with an open circuit and it exits at ports 2, and 3. On the other hand, the odd mode entering ports 2, and 3 sees a virtual short at D which is transformed into an open circuit by the  $\lambda/4$  Z1-line. Meanwhile, it sees a virtual short at C which is transformed into an open circuit by the  $\lambda/4$  Z3-line. As such, the odd mode travels completely through the Z2-line and gets directed towards, and absorbed, by the resistors. This happens perfectly at the center frequency,  $f_0$ . The basic idea is that we would like the even mode (entering port 1) to see a high impedance to the right of A1 and A2, and the odd mode to see a low impedance to the right of A1 and A2. This is achieved, in the Gysel divider, through the virtual opens/shorts and the associated  $\lambda/4$  transformations. Clearly, the bandwidth can be improved if we can control the impedances of the odd/even modes independently. At the same time, we would like to preserve the simplicity of the design and its low loss features. The proposed coupled-Gysel, Fig. 2a, replaces the Z2-line with a single coupled line. It turns out that replacing the other lines (Z1, and Z3) with coupled lines increases complexity/loss while adding negligible benefits. The even/odd mode equivalent circuits are shown on Figs. 2b, and 2c, respectively.

The only new design parameters are  $Z_{even}$  and  $Z_{odd}$ . Choosing  $Z_{even}$  is fairly simple. Since the even mode should see an open circuit, to the right of A1 and A2, we should choose  $Z_{even}$  as large as possible. Choosing  $Z_{odd}$  is more interesting. The odd mode sees a shorted (at D)  $\lambda/4$  Z1-line in parallel with the  $Z_{odd}$ -line. Choosing a  $Z_{odd}$  equal to 50  $\Omega$  gives a perfect match to the odd mode at  $f_0$ , as expected. Choosing  $Z_{odd} > 50$   $\Omega$  is disadvantageous as it directs more energy towards the Z1-line. Choosing  $Z_{odd} < 50$   $\Omega$  reduces the match at  $f_0$  at the expense of a larger bandwidth. Choosing  $Z_{odd}$  between 25 – 50  $\Omega$  increases the bandwidth while maintaining reasonable isolation ( $> 10 - 30$  dB) across the band.

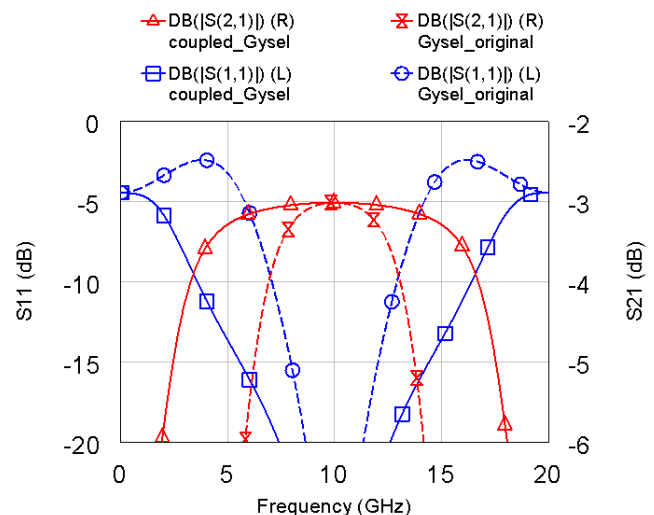

Fig. 3a. Simulation of S11 (left axis), and S21 (right axis) for classical (dotted lines), and coupled-Gysel (solid lines).

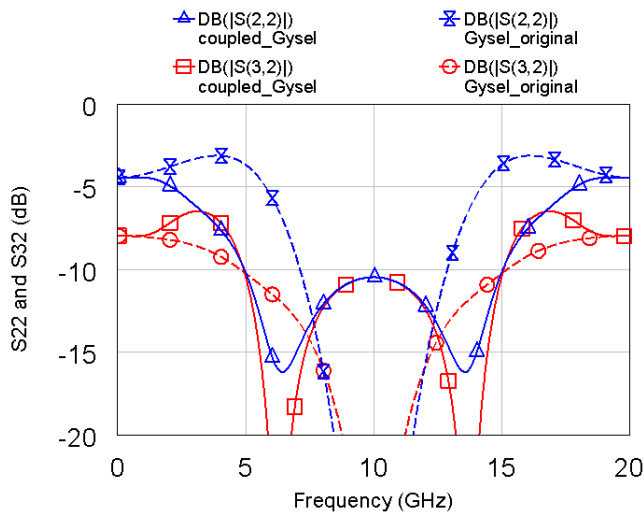

Fig. 3b. Simulation of S22, and S32 (isolation) for classical (dotted lines), and coupled-Gysel (solid lines).

Assuming a center frequency of 10 GHz, Figs. 3a, and 3b show a comparison between a classical and a coupled-Gysel, where  $Z_{even} = 250 \Omega$ , and  $Z_{odd} = 25 \Omega$  were used, as an example. If we define bandwidth as a 1 dB drop in insertion loss, then the classical Gysel covers 7 – 13 GHz (60% fractional bandwidth), and the coupled-Gysel covers 3.3 – 16.7 GHz (133% fractional bandwidth). If we define bandwidth by a minimum of 10 dB isolation, and input/output insertion loss, then the classical Gysel covers 7.12 – 12.88 GHz (57% fractional bandwidth), and the coupled-Gysel covers 4.95 – 15.05 GHz (101% fractional bandwidth).

### III. IMPROVED COUPLED-GYSEL IMPLEMENTATION

This section presents implementations (using Rogers® Duroid 6010 25-mil material) of the new divider as a verification of the theory. Two implementations are presented; a 2.5 – 8 GHz divider, and a 3.4 – 10.2 GHz divider. A picture of the fabricated 2.5 – 8 GHz divider is shown in Fig. 4, along with the layout. It measures  $0.2'' \times 0.6''$  only. The coupled line was implemented using two narrow microstrip lines with 3 mil width and a 2.1 mil gap (should support about 300 W CW before air breakdown) and equivalent  $Z_{even}$  and  $Z_{odd}$  impedances are  $150 \Omega$ , and  $Z_{odd} = 40 \Omega$ , respectively. The measured performance is shown in Fig. 5, along with the simulation. The bandwidth based on 1-dB insertion loss is 2.5 – 8 GHz (105% fractional bandwidth), and the insertion loss in the center of the band is 3.1 dB; hence the divider has 0.1 dB of loss. Close agreement between the simulation and measurement is observed. One of the contributing factors to the differences between them is that the SMT  $50 \Omega$  termination resistors perform poorly at high frequency as their S11 (line with circle symbols) shows in Fig. 5.

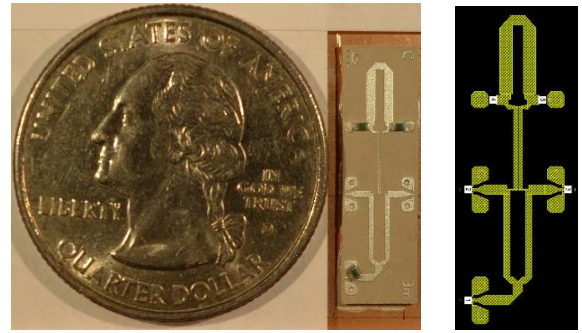

Fig. 4. Picture of coupled-Gysel divider covering 2.5 – 8 GHz.

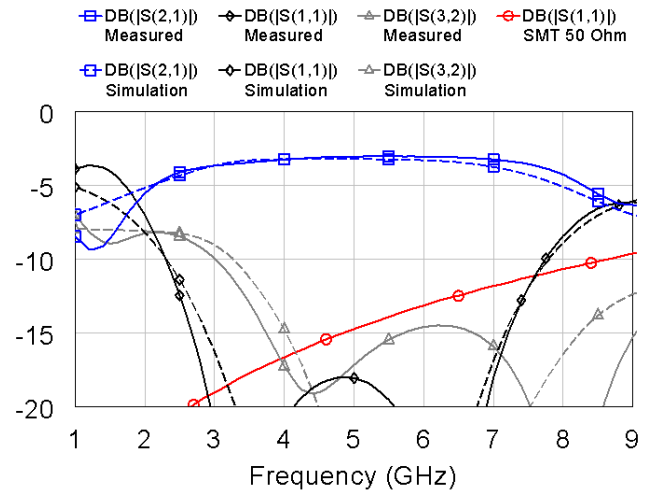

Fig. 5. Insertion loss, return loss, and isolation of 2.5 – 8 GHz coupled-Gysel divider. Also shown is the measured SMT  $50 \Omega$  termination.

A higher frequency divider was also implemented. Fig. 6 shows the simulation and measurement. The bandwidth based on the 1-dB insertion loss is 3.4 – 10.2 GHz (100% fractional bandwidth), and the RF loss in the center of the band is 3.2 dB; the divider's loss is 0.2 dB. Again, close agreement between the simulation and measurement is observed; an important source to the differences is SMT  $50 \Omega$  termination resistors.

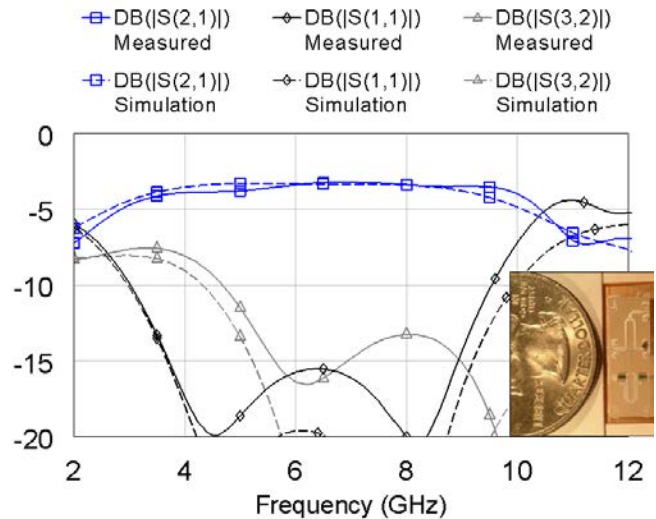

Fig. 6. Insertion loss, return loss, and isolation of 3.4 – 10.2 GHz coupled-Gysel divider. A picture of the fabricated divider is shown in the inset.

#### IV. CONCLUSION

A modified coupled-Gysel divider was introduced. It exhibits very broadband performance and low loss due to its simplicity and flexibility. The design procedure is straightforward with one parameter,  $Z_{odd}$ , to be selected. It was demonstrated with two cases, a 2.5 – 8 GHz (105% fractional bandwidth) case, and a 3.4 – 10.2 GHz (100% fractional bandwidth). To the best of our knowledge, this is widest bandwidth demonstrated for a Gysel divider. It has compact size making it suitable for MMIC implementation. In fact, a MMIC implementation is expected to show improved performance as a greater range of  $Z_{even}$  and  $Z_{odd}$  impedances and more precise terminating resistors can be realized.

#### REFERENCES

- [1] E. Wilkinson, "An N-way hybrid power divider," IRE Transactions on Microwave Theory Tech., vol. MTT-8, no. 1, pp. 116–118, Jan. 1960.
- [2] U. H. Gysel, "A new N-way power divider/combiner suitable for high-power applications," IEEE International Microwave Symposium Digest, pp. 116–118, 1975.
- [3] Y. Wu, Y. Liu, and S. Li, "A Modified Gysel Power Divider of Arbitrary Power Ratio and Real Terminated Impedances," IEEE Microwave and Wireless components letters, vol. 21, no. 11, pp. 601 – 603, 2011.
- [4] Z. Sun, L. Zhang, and Y. Yan, "A Novel Unequal Dual-band Gysel Power Divider," IEEE International Microwave Symposium, Baltimore, MD, 2011.
- [5] Z. Sun, L. Zhang, Y. Yan, and X. Tong "Modified Gysel Power Divider for Dual-Band Applications," IEEE Microwave and Wireless components letters, vol. 21, no. 1, pp. 16 – 18, 2011.
- [6] J. Li, Y. L. Wu, Y. Liu, J. Shen, S. Li, and C. Yu, "A Generalized Coupled-Line Dual-Band Wilkinson Power Divider with Extended Ports," Progress in Electromagnetic Research, vol. 129, pp. 197 – 214, 2012.
- [7] K. X. Wang, X. Y. Zhang, and B. Hu, "Gysel Power Divider With Arbitrary Power Ratios and Filtering Responses Using Coupling Structure," IEEE Transactions on Microwave Theory and Tech., vol. 62, no. 3, pp. 431 – 440, 2014.
- [8] W. Wang, Y. Wu, and Y. Liu, "A Novel High-Power Dual-Band Coupled-Line Gysel Power Divider with Impedance-Transforming Functions," The Scientific World Journal, vol. 2014, article ID 831073, 2014.
- [9] Ali Darwish, Amr A. Ibrahim, Joe Qiu, Ed Viveiros, and H. Alfred Hung "A Broadband 1-to-N Power Divider/Combiner with Isolation and Reflection Cancellation," IEEE Transactions on Microwave Theory and Techniques, April 2015.
- [10] Ali Darwish, Amr A. Ibrahim, Joe Qiu, Ed Viveiros, and H. Alfred Hung "Divider/Combiner with Enhanced Isolation and Reflection Cancellation," IEEE Int'l Microwave Symposium, Phoenix, AZ, 2015.