

Ka-Band Waveguide Hybrid Combiner for MMIC Amplifiers With Unequal and Arbitrary Power Output Ratio

Rainee N. Simons, Christine T. Chevalier*, Edwin G. Wintucky, and Jon C. Freeman

Mail Stop 54–5, NASA Glenn Research Center, 21000 Brookpark Road, Cleveland, OH 44135, USA

*Analex Corporation, Cleveland, OH 44135, USA

Abstract — The design, simulation and characterization of a novel Ka-band (32.05 ± 0.25 GHz) rectangular waveguide branch-line hybrid unequal power combiner is presented. The manufactured combiner was designed to combine input signals, which are in phase and with an amplitude ratio of two. The measured return loss and isolation of the branch-line hybrid are better than 22 and 27 dB, respectively. The application of the branch-line hybrid for combining two MMIC power amplifiers with output power ratio of two is demonstrated. The measured combining efficiency is 92.9% at the center frequency of 32.05 GHz.

Index Terms — Hybrid junctions, microwave communications, MMIC power amplifiers, power combiners, satellite communications, waveguide couplers, waveguide junctions.

I. INTRODUCTION

NASA plans to return humans to the Moon as a part of the Exploration Program and is therefore developing a new Crew Exploration Vehicle (CEV), which is called Orion [1]. In addition, a Lunar Lander is also being planned, which is called Altair [2]. The Orion and the Altair require microwave power amplifiers for communications with the International Space Station (ISS) and the Lunar Relay Satellite, respectively. Amplifiers with output power on the order of a few tens of watts at Ka-Band frequencies are adequate for the given data rates and distances that are involved. A solid-state power amplifier (SSPA) would be capable of meeting the above power requirements.

The highest power Ka-Band (31.8 to 32.3 GHz) SSPA to have flown in space had an output power of 2.6 watts and an overall efficiency of 14.3% [3]. This SSPA was built around discrete GaAs pHEMT devices and flew on-board the Deep Space One spacecraft. Since that time monolithic microwave integrated circuit (MMIC) power amplifier (PA) technology has significantly advanced. The state-of-the-art (SOA) GaAs pHEMT based MMICs are capable of delivering RF power anywhere from 3 watts with a power added efficiency (PAE) of 32% to 6 watts with a PAE of 26%, at Ka-Band frequencies [4]. To achieve power levels higher than 6 watts, the output from several MMIC PAs have to be combined using a power combiner. Conventional binary waveguide power combiners, such as the short slot and magic-T based, require MMIC PAs with identical amplitude and phase characteristics for high combining efficiency. However, due to manufacturing process

variations, the output power of the MMIC PAs tends to be unequal. In the past, several researchers have investigated rectangular waveguide unequal power combiners, which are based on shunt/series coupling slots [5], E-plane septums [6], H-plane T-junctions [7], and an asymmetric magic-T [8]. The unequal power combiners surveyed above operated at or below X-Band frequencies.

In this paper, we present a novel Ka-Band branch-line hybrid with arbitrary power combining ratio and port impedance. These features result in several advantages, which are as follows: first, the design is very flexible. The flexibility allows the combiner to be customized for combining the power from MMIC PAs with arbitrary power output ratio. In addition, it also allows combining a low power GaAs MMIC with a high power GaN MMIC. Second, the arbitrary port impedance allows matching the output impedance of the MMIC PA directly to the waveguide impedance without transitioning first into a transmission line with characteristic impedance of 50Ω . Thus by eliminating the losses associated with a transition, the overall SSPA efficiency is enhanced. Third, for reducing the cost and weight when required in very large quantities, such as in the beam forming networks of phased array antenna systems, the combiner can be manufactured using metal-plated plastic [9]. Fourth, two hybrid unequal power combiners can be cascaded to realize a non-binary combiner (for e.g., a 3-way) and can be synergistically optimized for low VSWR, low insertion loss, high isolation and wide bandwidth using modern software design tools. However, for the purpose of this demonstration we have fabricated a branch-line hybrid with fixed power combining ratio of two and with port impedances matched to that of a standard WR-28 waveguide. The results presented for the branch-line hybrid include the measured and simulated return loss, power output ratio, isolation and efficiency. Lastly, we demonstrate high efficiency power combining of two Ka-Band GaAs pHEMT MMIC PAs with power output ratio of two.

II. KA-BAND WAVEGUIDE HYBRID POWER COMBINER LAYOUT

The branch-line hybrid combiner is constructed in an E-plane split-block arrangement. The lower half of the combiner is

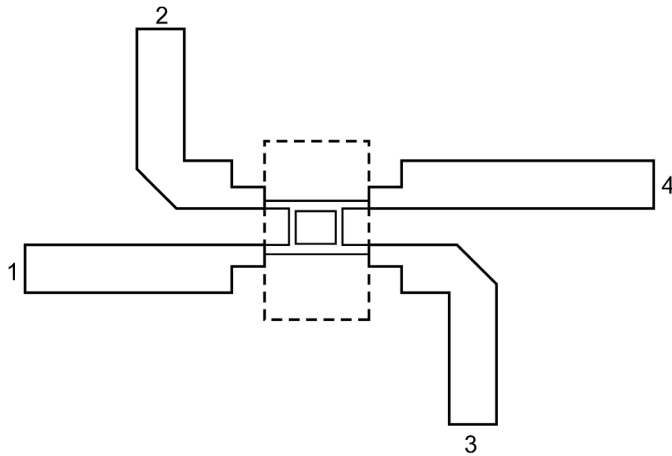

Fig. 1. Illustration of the lower half of the waveguide branch-line hybrid power combiner, which includes the E-plane stepped impedance transformers to standard WR-28 waveguide and mitered right-angled bends. The dotted area in the center is the basic hybrid combiner.

illustrated in Fig. 1. In this figure, the dashed box indicates the basic hybrid combiner with arbitrary power combining ratio and port impedance. The port impedances are matched to that of a standard WR-28 waveguide by using E-plane stepped impedance transformers. In the H-plane, the combiner dimensions are identical to that of the standard WR-28 waveguide. A mitered right angle bend is added to orient the ports along the four faces of the block for ease of characterization.

III. POWER COMBINER MODELING AND SIMULATION

For the purpose of this demonstration, we designed the circuit for operation over the 500 MHz bandwidth centered at 32.05 GHz which corresponds to the designated NASA deep space frequency band. The circuit is a 2:1 in-phase power combiner; that is, the ratio of the coherent power incident at ports 3 and 4 is 2. Port 1 is the combined output port and port 2 is isolated. Since the circuit is reciprocal, we initially modeled/simulated the basic hybrid combiner within the dashed box as a power divider by exciting port 1. The goal was to achieve a 2:1 power split between ports 3 and 4 with minimum reflection at port 1 and high isolation between ports 1 and 2. This was accomplished by using the transient solver of the software package CST Microwave Studio [10]. Perfect electrical conductors were assumed. The solver varied the length and width of the waveguide sections in the branch-line hybrid to achieve the above goals. The solver assumed 15 mesh lines per wavelength, which resulted in a total of approximately 14,000 mesh cells. Each simulation took less than 1 minute on a Hewlett-Packard xw6400 workstation.

Next, the transition to standard WR-28 waveguide using stepped impedance transformers and also mitered right-angled bends were added to the basic circuit. In addition, we lengthened the distance to port 4 from the junction so that the signals at ports 3 and 4 are in phase for maximum combining.

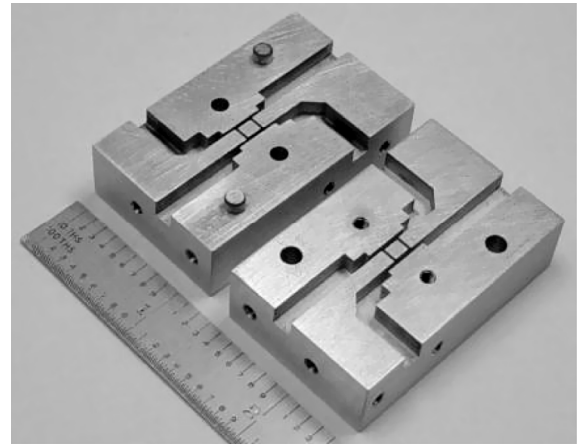

Fig. 2. Photograph of the fabricated 2:1 Ka-Band branch-line hybrid power combiner in an E-plane split block arrangement. The dimensions of the assembled combiner are 1.8 by 1.2 by 1 in.

The complete circuit was once again simulated and optimized as a power divider using CST Microwave Studio. The simulated S_{31} and S_{41} at the center frequency of 32.05 GHz are -1.79 and -4.81 dB, respectively, resulting in 99.3% efficiency. The fabricated branch-line hybrid combiner is shown in Fig. 2.

IV. MEASURED AND MODELED RESULTS

The power combiner is characterized as a power divider using a calibrated Agilent Technologies Model E8363B network analyzer. Fig. 3 presents the measured and simulated return loss (S_{11}) at the excitation port 1 as a function of the frequency. The measured return loss is better than 22 dB across the 500 MHz bandwidth.

In Fig. 4, the measured and simulated amplitude of the signal coupled to the output port 3 (S_{31}) and port 4 (S_{41}) as a function of the frequency are presented. In Fig. 5, the measured and simulated phase difference between the signals coupled to the output port 3 and port 4 (phase of S_{31} – phase of S_{41}) are presented. Across the 500 MHz bandwidth the measured signal amplitude deviates from the simulated values by a maximum of 0.35 dB and the measured phase difference deviates from the simulated values by 20° .

Fig. 6 presents the measured and simulated signal isolation between the excitation port 1 and the isolated port 2 (S_{21}). Fig. 7 presents the measured and simulated signal isolation between the output port 3 and port 4 (S_{43} and S_{34}). It is observed from these figures that across the 500 MHz bandwidth, the measured isolation is better than 27 dB, which is considered to be excellent.

The low insertion loss, good phase characteristics, high isolation between ports 1 and 2, and between ports 3 and 4, make this circuit very efficient. If used as a combiner, with ports 3 and 4 as the inputs, then from the above measured data, the efficiency is in the range of 93.5 to 95.5% over the 500 MHz bandwidth, as shown in Fig. 8.

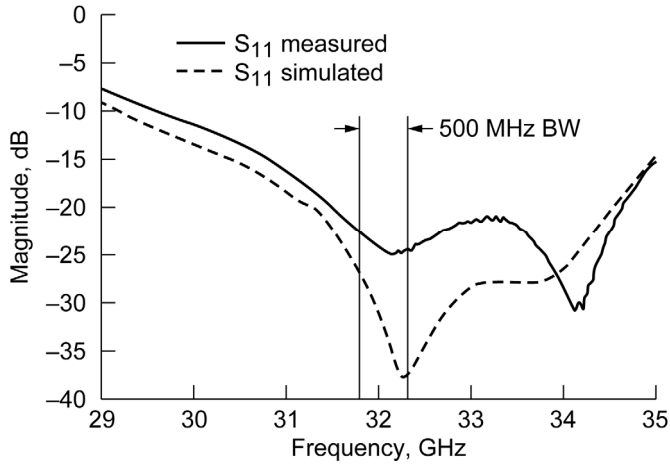

Fig. 3. Measured and simulated return loss (S_{11}) at the excitation port 1 as a function of the frequency.

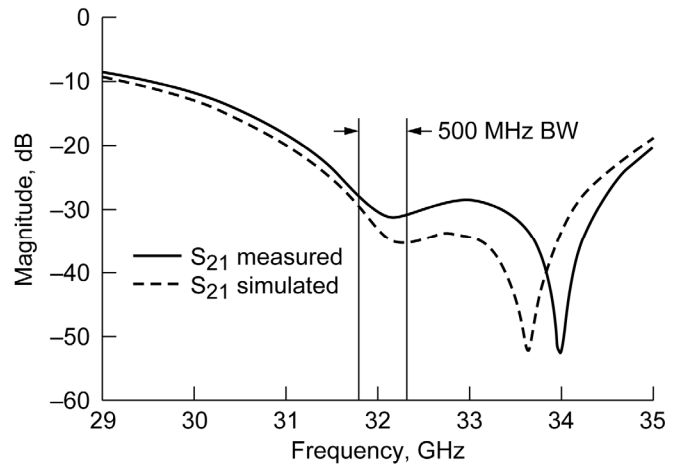

Fig. 6. Measured and simulated signal isolation between the excitation port 1 and the isolated port 2 (S_{21}) as a function of the frequency.

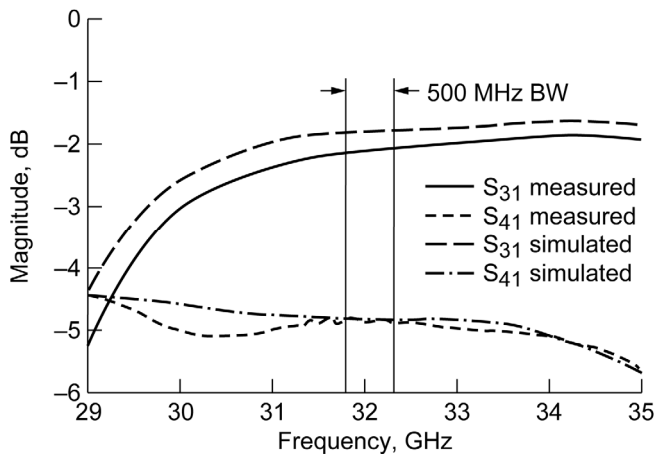

Fig. 4. Measured and simulated amplitude of the signal coupled to the output port 3 (S_{31}) and port 4 (S_{41}) as a function of the frequency.

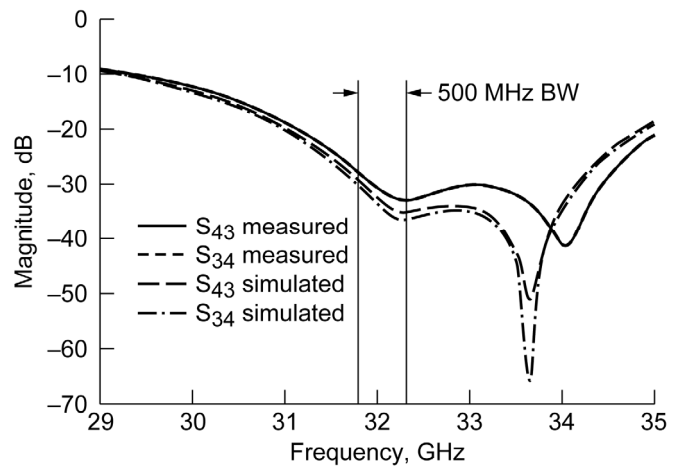

Fig. 7. Measured and simulated isolation between the output port 3 and port 4 (S_{43} , S_{34}) as a function of the frequency.

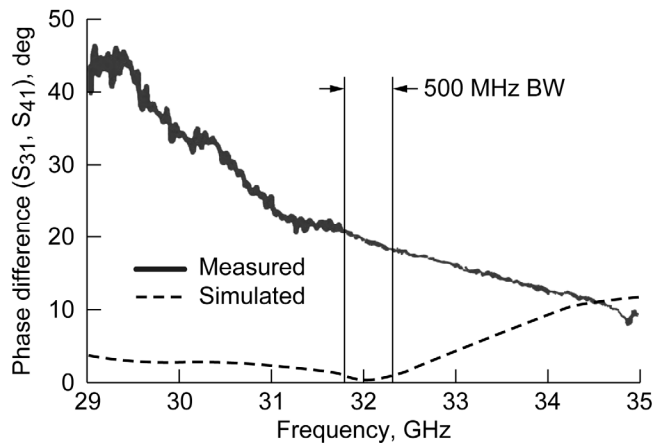

Fig. 5. Measured and simulated phase difference of the signal coupled to the output port 3 and port 4 (phase of S_{31} - phase of S_{41}) as a function of the frequency.

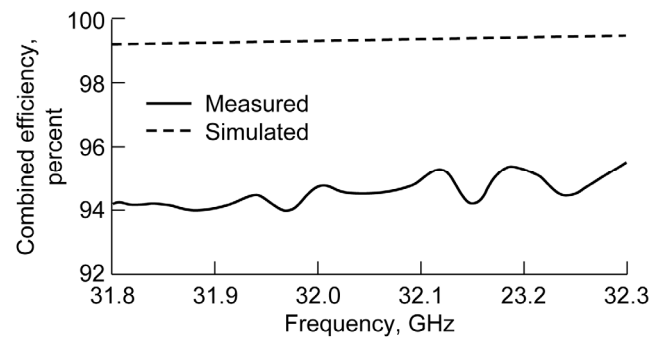

Fig. 8. Measured and simulated combiner efficiency as a function of the frequency.

V. COMBINING OF KA-BAND MMIC POWER AMPLIFIERS

The GaAs pHEMT MMIC amplifiers in our experimental set-up, illustrated in Fig. 9, are the model XP1026 and the model XP1027 manufactured by Mimix Broadband [11]. For this experiment, the MMICs are mounted in coaxial test fixtures and include the bias circuitry. The MMIC PAs are then coupled via a coax-to-waveguide adapter to ports 3 and 4 of the branch-line hybrid, respectively. At the design center frequency of 32.05 GHz, the input power to port 4 from XP1026 is 0.5 watt and to port 3 from XP1027 is 1.0 watt. The phase shifter is adjusted for maximum combined power (P_{out}) at port 1. The corresponding measured combined power at port 1 is 1.393 watts, which translates into a combining efficiency of 92.9%. Change in phase shifter setting by $\pm 15^\circ$ was observed to result in $<0.25\%$ decrease in P_{out} as shown in Fig. 10. Low sensitivity to phase variation implies potential applications in high bandwidth and high data rate communications.

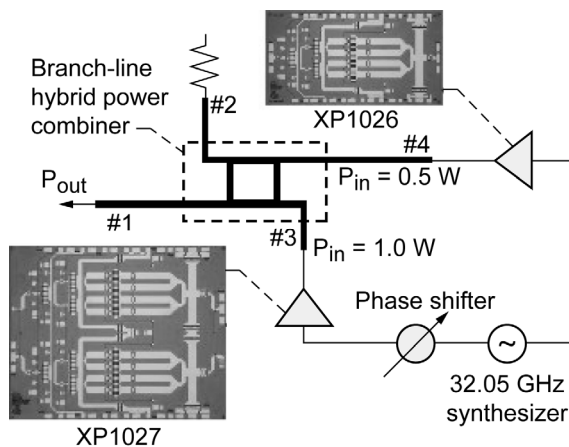

Fig. 9. Schematic of experimental set-up for demonstrating power combining of GaAs pHEMT MMIC amplifiers with unequal power output using the branch-line hybrid.

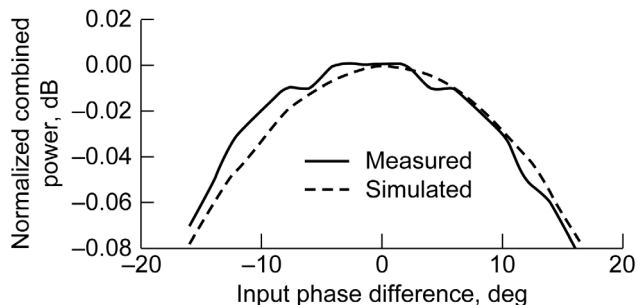

Fig. 10. Measured and simulated normalized combiner power output as a function of input phase difference.

VI. CONCLUSIONS AND DISCUSSIONS

The design, modeling/simulation and characterization of a novel Ka-Band (32.05 ± 0.25 GHz) rectangular waveguide branch-line hybrid unequal power combiner are presented. The manufactured combiner is designed to combine input signals, which are in phase and with an amplitude ratio of two. The measured return loss and isolation of the branch-line hybrid are better than 22 and 27 dB, respectively across the band of interest. The application of the branch-line hybrid for combining two MMIC power amplifiers with output power ratio of two is demonstrated. The combining efficiency is 92.9% at the center frequency of 32.05 GHz. We have demonstrated high efficiency power combining. This permits the use of other than binary combining, which allows the use of fewer combiners to develop SSPAs with power levels in the tens of watts.

ACKNOWLEDGEMENT

The authors acknowledge the precision fabrication of the branch-line hybrid combiner by Astro Manufacturing & Design, Eastlake, Ohio. The authors thank James M. Downey for the hybrid combiner S-parameter measurements.

REFERENCES

- [1] http://www.nasa.gov/mission_pages/constellation/orion/index.html
- [2] http://www.nasa.gov/mission_pages/constellation/altair/index.html
- [3] M.K. Karnacewicz, W.J. Taft, S. Valenti, T. Renna, M. Hirokawa, S. Conway and L. Newman, "2.6 Watt Ka-Band Solid State Power Amplifier for Deep Space Communications," 1999 Government Microcircuit Applications Conference (GOMAC 1999) Digest of papers, Vol. XXIV, pp. 247-250, Monterey, CA, March 8-11, 1999.
- [4] P.M. Smith, "PHEMT and MHEMT Devices for Millimeter-Wave Power Amplifiers," Workshop (WMD) on Millimeter-Wave Power Amplifier Technology: Power, Linearity and Efficiency, 2008 IEEE MTT-S Int. Microwave Symp., Workshop Notes, Atlanta, Georgia, June 16, 2008.
- [5] P.K. Park, M.E. Slaterbeck, and S.E. Bradshaw, "Shunt/Series Coupling Slot in Rectangular Waveguides," 1984 IEEE Antennas & Propagation Society Int. Symp., Boston, MA, pp. 62-65, June 25-28, 1984.
- [6] S. Christopher, V.A. Abid Hussain, M.S. Easwaran and V.N. Dabade, "Design Aspects of Compact High Power Multiport Unequal Power Dividers," 1996 IEEE Int. Symp., on Phased Array Systems and Technology, pp. 63-67, Boston, MA, Oct. 15-18, 1996.
- [7] T. Takahashi, S. Sakanaka, and M. Izawa, "Development of an Asymmetric Power Divider for a High-Power RF Distribution System," IEEE Trans. Nuclear Science, Vol. 48, No. 4, Part 3, pp. 1592-1597, Aug. 2001.
- [8] S. Yang and A.E. Fathy, "Synthesis of a Compound T-Junction for a Two-Way Splitter With Arbitrary Power Ratio," 2005 IEEE MTT-S Int. Microwave Symp., Dig., pp. 985-988, Long Beach, CA, June 12-17, 2005.
- [9] H. Asao, K. Henmi, M. Mukuda, and N. Yoneda, "Ku-Band Power Combiner Composed of Metal-Plated Plastic Waveguide Hybrid," 2004 IEEE MTT-S Int. Microwave Symp., Dig., Vol. 2, pp. 625-628, Fort Worth, TX, June 6-11, 2004.
- [10] <http://www.cst-america.com>
- [11] <http://www.mimixbroadband.com>