

# Computing Trimmable Angle of Attack for Aircraft with Control Failures

Joseph Kaloust  
Department of Engineering  
Hope College  
Holland, MI 49422-9000, USA

David B. Doman  
Air Force Research Laboratory  
Air Vehicles Directorate  
WPAFB, OH 45433-7531, USA

*Abstract*—A method is presented for computing the range of angle of attack for which an air vehicle can be rotationally trimmed when experiencing control effector failures. The algorithms are applied to an unpowered reentry vehicle as an example. Types of failures considered include floating effectors that do not contribute to the aerodynamic forces and moments and also to cases where effectors are locked at a given position within the effector displacement range. The algorithm can provide critical information to online trajectory generators and path planners for autonomous air vehicles.

## Table of Contents

1	Introduction	1
2	Problem Formulation	2
3	NLAMS Algorithm	4
4	Results	5
5	Conclusions	6

## 1. Introduction

The algorithm presented here makes use of portion of a direct control allocation algorithm method that was previously developed by Durham[1][2]. The direct control allocation approach requires the computation of an Attainable Moment Set (AMS) that describes a volume in moment space. Points inside of this volume can be reached by deflecting the vehicle control surfaces in some physically realizable configuration. The basic idea behind direct allocation is to determine the boundaries of an attainable moment set to solve a constrained control allocation problem. In the event that the desired moment lies outside of the AMS volume, the direction of the command is preserved but clipped at the AMS boundary. Durham's algorithm for computing the AMS uses simple geometric notions to determine the boundary by computing a three dimensional geometric shape in the moment space  $\mathbf{G} \in \mathbb{R}^3$  and  $\mathbf{G} = [L, M, N]$ , where  $L$  is the rolling moment,  $M$  is the pitching moment, and  $N$  is the yawing

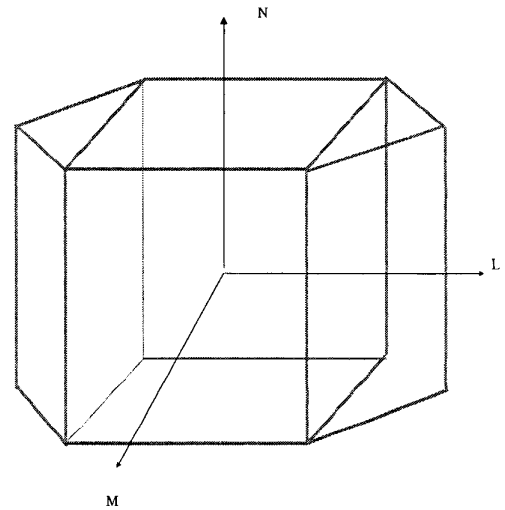

**Figure 1.** Attainable Moment Set (AMS) 3-D geometrical shape

moment. A non-dimensional form of the moment vector is also useful, since aircraft force and moment increments are commonly non-dimensionalized. The notation for the non-dimensional form of the moment vector is now introduced as  $\mathbf{C}_G = [C_l, C_m, C_n]$ . A conceptual example of an AMS is shown in Figure 1 in terms of the moments. For a more detailed explanation of the calculation of an AMS, the reader is referred to references[1]-[4].

Durham's algorithm is based on the assumption that the control effectors (surfaces) are individually linear in their effect throughout their ranges of motion. In other words, the algorithm assumes that the aerodynamic moments can be expressed as linear combinations of the deflections  $\mathbf{G} = \mathbf{B}\delta$  where  $\mathbf{B}$  is the control effectiveness matrix, and  $\delta$  is the control deflection vector. This assumption implies that the vehicle is already trimmed, i.e., the vehicle is stable with zero rotational motion at a given flight condition.

The idea of an AMS is useful when an aircraft experiences control effector failures and one is interested in computing the range of angle of attack over which the aircraft can be rotationally trimmed. It is clear that the AMS volume decreases as control surfaces fail. This reduction in volume can translate into a reduced range of flight conditions over which the vehicle can be trimmed. In order to trim at a given flight condition, the moment generated by the wing-body-propulsion or "base" system must be cancelled by some combination of control effector deflections. Both the base and control moment vectors can change as a function of flight condition. It is not physically possible to rotationally trim the vehicle under any conditions for which the tip of the base moment vector lies outside of the AMS volume.

Some complications arise when attempting to use Durham's AMS algorithm to compute the range of trimmable angle of attack. One must consider the fact that the moments generated by the effectors are generally nonlinear functions of the control deflections, and that the vehicle may not be trimmed at certain flight conditions. A rotationally trimmed vehicle satisfies the following set of equations:

$$\begin{aligned} L_0(\alpha, \beta, \text{Mach}) + L_\delta(\alpha, \beta, \text{Mach})\delta &= 0 \\ M_0(\alpha, \beta, \text{Mach}) + M_\delta(\alpha, \beta, \text{Mach})\delta &= 0 \\ N_0(\alpha, \beta, \text{Mach}) + N_\delta(\alpha, \beta, \text{Mach})\delta &= 0 \end{aligned} \quad (1)$$

where  $\delta$  is a vector of effector deflections,  $L_0$ ,  $M_0$  and  $N_0$  are the base (wing-body-propulsion system) rolling, pitching and yawing moments respectively,  $L_\delta$ ,  $M_\delta$ , and  $N_\delta$  are the control effector rolling, pitching and yawing moments respectively, and  $\delta_{min} \leq \delta \leq \delta_{max}$ .

Part of this research concentrates on extending the Durham's AMS algorithm for an un-trimmed vehicle with a nonlinear aerodynamic database. An unpowered re-entry vehicle model was chosen to test and verify the effectiveness of the algorithm in computing the trimmable range of angle of attack for different effector failures. It is worth noting that this algorithm can be applied to any air-vehicle and is not limited to unpowered re-entry vehicles. The re-entry vehicle under consideration has 8 aerodynamic control surfaces, left-right body flaps, left-right inboard/outboard elevons and two rudders.

## 2. Problem Formulation

In this section, we shall discuss the development of two separate algorithms. Both algorithms compute the range of trimmable angle of attack  $\alpha$  under certain effector failures. The first algorithm was used to establish a benchmark that could be used to verify the proper operation of a faster and more general algorithm. The benchmark algorithm uses the nonlinear aerodynamic database to compute the exact range of attainable angle of attack directly from the vehicle aerodynamic database. The algorithm simply uses vehicle flight conditions such as Mach number, sideslip angle  $\beta$ , effector

displacement limits ( $\delta_{min}$  and  $\delta_{max}$ ), and type of effector failure(s) to compute a range of attainable angle of attack. This calculation compares the base pitching moment coefficients to the maximum and minimum pitching moment coefficients that are possible due to effector displacements. Finally, it is determined whether or not the base moment coefficient lies between the maximum and minimum moment coefficients that can be generated by the effector suite. That is, if

$$C_{M_{min}} \leq C_{M_0} \leq C_{M_{max}} \quad (2)$$

then the vehicle can be rotationally trimmed at the flight condition at which the moment coefficients were evaluated. Note that  $C_{M_{min}}$  and  $C_{M_{max}}$  denote the maximum and minimum pitching moment coefficients that the control effector suite is capable of generating subject to the constraint that the roll and yaw axes are trimmed.

A graphical representation of the above equation is presented in Figure 2. Under all effector failures, the base pitching moment  $C_{M_0}$  is unaffected while the minimum and maximum pitching moment bounds vary according to the type of effector failure(s). In Figure 2, the black solid line representing the base moment coefficient does not change when an effector fails; however, the red (maximum pitching moment coefficient) and blue (minimum pitching moment coefficient) solid lines change depending on the type of effector failure(s).

Two additional examples are presented where the benchmark algorithm is utilized. These examples are shown in Figures 3 and 4 and graphically illustrate the range of angle of attack over which the vehicle can be trimmed under a given flight condition and effector failure(s). Figure 3 shows an example where the body flaps are locked at their maximum displacement of 26 degrees. For this case, the vehicle can be trimmed over the following range of angle of attack:  $\alpha \in [0^\circ, 4^\circ]$ . This is where the base pitching moment coefficient (black line) lies between the maximum (red line) and minimum (blue line) control effector induced pitching moment coefficients. The vehicle cannot be trimmed in regions where the sum of the base and failed effector pitching moment coefficients lie outside of the maximum and minimum moment coefficients that can be generated by the un-failed effectors.

Figure 4 shows an example where the vehicle lost hinge moment control of both body flaps (floating flap failures). From the figure, one can see that the vehicle can be trimmed for the range of angle of attack ( $\alpha \in [13^\circ, 50^\circ]$ ).

The principle disadvantage of this benchmark algorithm is that its application is limited to symmetric failures. The advantage of the second algorithm, which we shall refer to as Non Linear Attainable Moment Set (NLAMS), lies in its ability to compute a range of angle of attack for any and all possible combinations of effector failures.

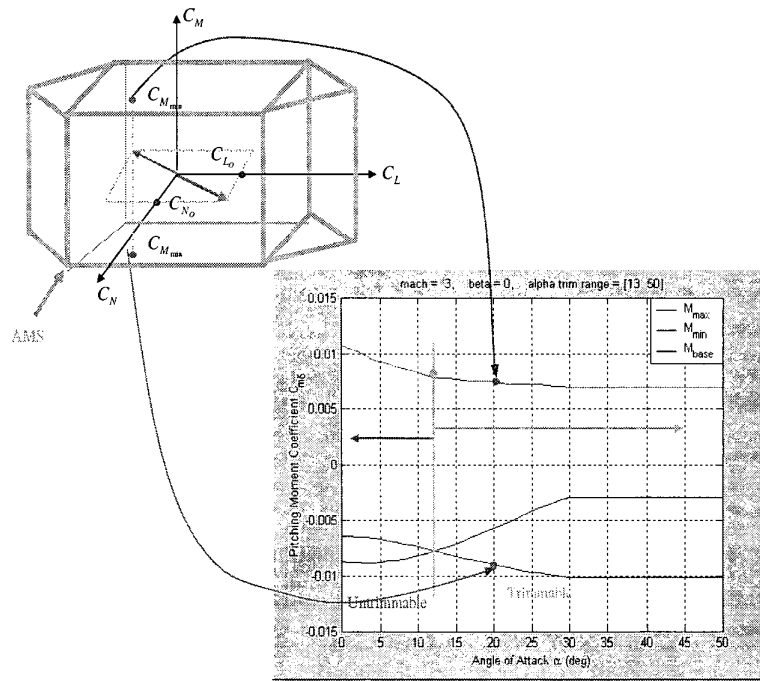

**Figure 2.** : Pitching moment coefficients (min,max,base) shown in 3-D moment coefficient space at fixed angle of attack and corresponding points on a pitching moment coefficient vs. angle of attack plot.

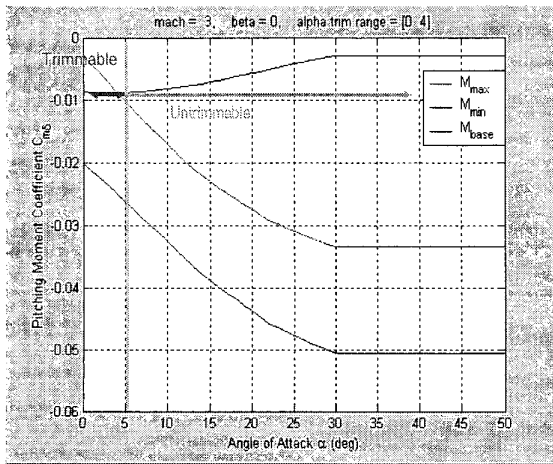

**Figure 3.** Determination of trimmable angle of attack for a failed left and right flap (locked at 26°)

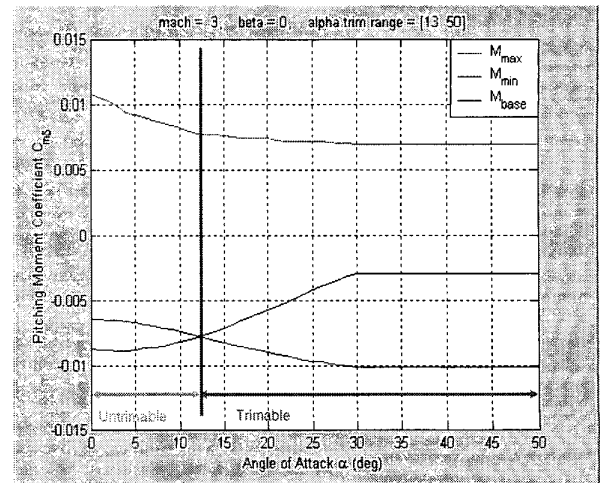

**Figure 4.** Determination of trimmable angle of attack range for a failed right-left flap (floating at 0°)

### 3. NLAMS Algorithm

The objective of the NLAMS algorithm is to quickly estimate the range of trimmable angle of attack for any given flight condition and under any type of effector failure(s). Algorithm development concentrated on ways to extend/modify the AMS algorithm developed in Reference[1]. Specific assumptions that were relaxed in this formulation are:

1. A linear relationship exists between the moments and the control effector positions, i.e.,  $(\mathbf{G} = \mathbf{B}\delta)$
2. The vehicle is trimmed about an operating point.

The NLAMS algorithm uses the nonlinear aerodynamic database instead of a linearized aerodynamic model that assumes that the vehicle is in a trimmed state. Instead, NLAMS trims the vehicle's rolling and yawing moments first and then calculates the extremal values of the pitching moment or pitching moment coefficient that the effectors can generate. Portions of Durham's AMS algorithm [1] were unchanged, such as the method used to determine boundary facets. The assumption of linearity was relaxed and replaced by the assumption that the moments could be expressed as a sum of monotonic functions of individual surface deflections. This assumption implies that there are no moment interactions between the surfaces and that the maximum and minimum moments that a surface will contribute to the total vehicle moment, occurs at maximum or minimum deflections.

The operation of the NLAMS algorithm can be summarized as follows:

1. It is assumed that the flight condition (Mach number and sideslip angle), effector displacement range, and the failure(s) are known or measurable
2. Four points in moment space are computed by moving 2 effectors to their minimum and maximum position limits while the remaining effectors are locked at their limits. The roll components of these points are computed as follows:

$$L_1 = L(\alpha, \beta, \text{Mach}, \delta_{i_{\min}}, \delta_{j_{\min}})$$

$$L_2 = L(\alpha, \beta, \text{Mach}, \delta_{i_{\min}}, \delta_{j_{\max}})$$

$$L_3 = L(\alpha, \beta, \text{Mach}, \delta_{i_{\max}}, \delta_{j_{\min}})$$

$$L_4 = L(\alpha, \beta, \text{Mach}, \delta_{i_{\max}}, \delta_{j_{\max}})$$

where each calculation is performed with all  $k \neq i, j$  control effectors set at their position limits in some combination. Analogous expressions are used to compute the pitch and yaw components of each point. This portion of the NLAMS algorithm is similar to the procedure for computing vertices of a linear AMS as described in [1].

3. Each set of the four points calculated in the previous step are used to compute a facet or plane of best-fit using quadratic cost criteria.
4. Each facet is evaluated to determine whether or not it lies on the NLAMS boundary using the method described in Reference [1].

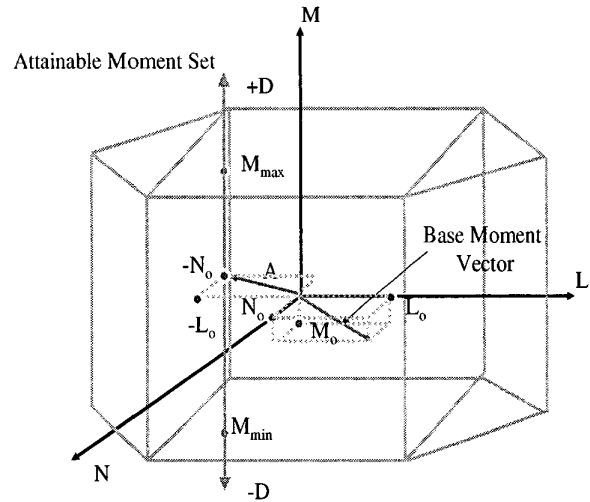

Figure 5. The base moment vector inside of an AMS

5. For each boundary facet the following four steps are performed.

(a) First, a vector  $\mathbf{A}$  is constructed such that it trims the vehicle in the roll and yaw axes. That is, a vector  $\mathbf{A} = [-L_0, 0, -N_0]$  is selected, which ensures that the vehicle is trimmed in the roll and yaw axes (refer to Figure 5).

(b) A vector  $\mathbf{D}$  is extended parallel to the pitching moment axis  $\mathbf{M}$  until the vector  $\mathbf{D}$  intersects the plane of best fit. In other words the vector  $\mathbf{D}$  is chosen as  $\mathbf{D} = [-L_0, \pm M_\infty, -N_0]$ , where  $M_\infty$  denotes a large value of pitching moment that is guaranteed to produce a value of  $\mathbf{D}$  that extends beyond the AMS boundary.

(c) Finally, the point of intersection between the boundary plane and the vector  $\mathbf{D}$  is computed. The distance from the point of intersection to the point  $[-L_0, 0, -N_0]$  is the maximum (for  $+M_\infty$ ) or minimum (for  $-M_\infty$ ) attainable pitching moment as shown in Figure 5.

6. Since multiple boundary facets exist, the NLAMS algorithm must determine the correct maximum and minimum pitching moments and the corresponding effector positions. This is accomplished by utilizing the nonlinear aerodynamic database and incrementing the angle of attack  $\alpha$  over some range of interest. For each of angle of attack evaluated, the nonlinear aerodynamic database is used to compute the base pitching moment  $M_0(\alpha, \beta, \text{Mach})$  as well as the maximum ( $M_{max}$ ) and minimum ( $M_{min}$ ) pitching moments that can be generated by the effector suite. If the base pitching moment coefficient  $M_0(\alpha, \beta, \text{Mach})$  lies between the minimum and maximum pitching moment coefficients (inside the AMS volume), then the vehicle can be trimmed in the pitch axis. The range of trimmable angle of attack  $\alpha$  can thus be determined.

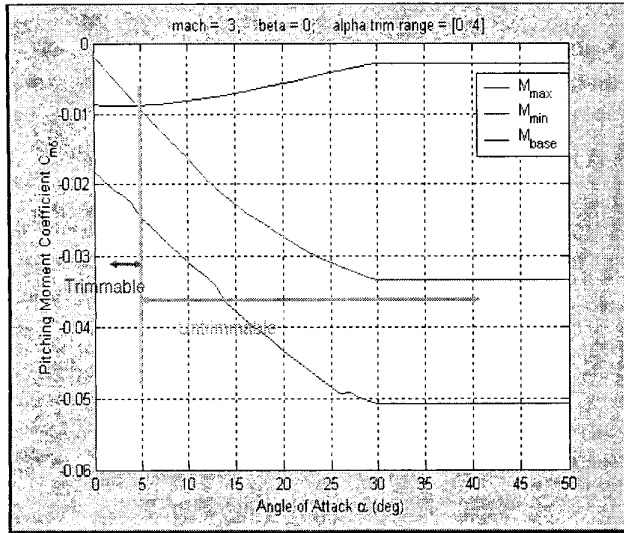

**Figure 6.** Determination of trimmable angle of attack for failed left-right flaps (locked at  $26^\circ$ )

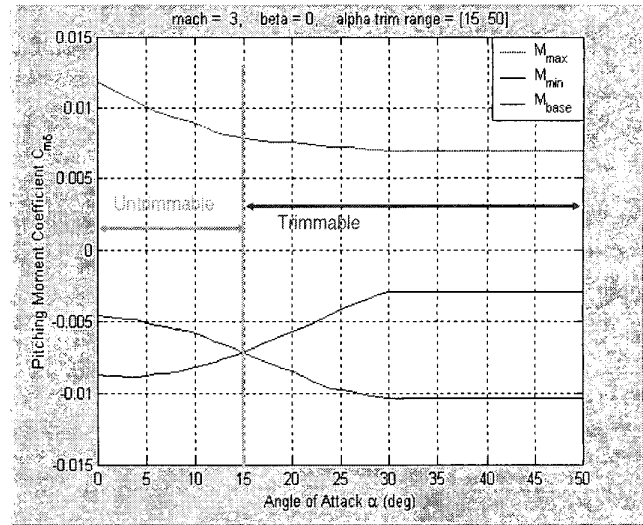

**Figure 7.** Determination of trimmable angle of attack for failed left-right flaps (floating at  $0^\circ$ )

#### 4. Results

Four examples are presented in this section. The first three cases examine symmetric failures and are used to verify that the NLAMS algorithm provides results that compare favorably to the benchmark algorithm. The fourth example is a non-symmetric effector failure that cannot be solved using the benchmark algorithm. The simulation results are tabulated in Table 1. All cases are for Mach = 3 and zero sideslip angle.

Figures 6-8 graphically show the range of trimmable angle of attack for the first three cases. Case 1, corresponds to a symmetric flap failure where both the left and right flaps are fixed at  $26^\circ$ . As a result the vehicle can only trim at this flight condition between 0 and 4 degrees angle of attack. Both the benchmark and NLAMS algorithm predict the same range of trimmable angle-of-attack.

In case 2, the NLAMS and benchmark results vary slightly because of the the assumption that the NLAMS surface consists of planar facets. That is, the NLAMS calculation of the moment vector intersection with the AMS boundary facet is performed using least squares planar approximation of the nonlinear AMS boundary, based only on four points on that surface. Figures 9 and 10 illustrate this point.

Case 3 is a symmetric failure where both the left and right flaps are locked at  $-15^\circ$ . From Figure 8, one can see that both the benchmark and NLAMS algorithm predict that this failure will cause the vehicle to become untrimmable for the given flight condition.

The current algorithm computes the points on the nonlinear AMS boundary using a nonlinear aerodynamic database. The

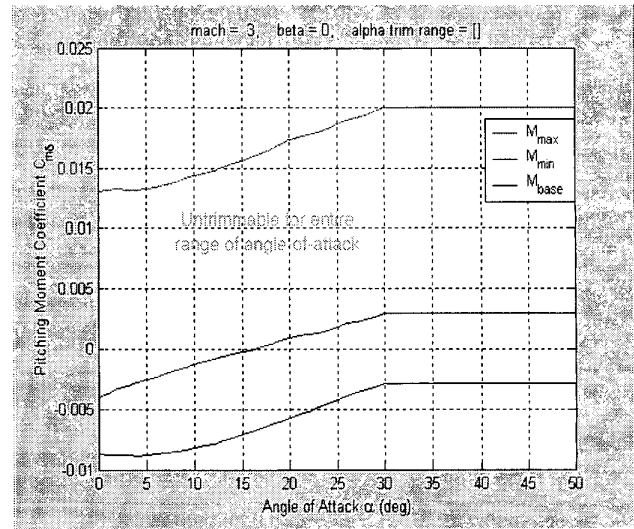

**Figure 8.** Determination of trimmable angle of attack for failed left-right flaps (locked at  $-15^\circ$ )

surface used to approximate the nonlinear AMS boundary is a plane; however, the actual surface may be nonlinear with convex or concave features. Thus, one must bear in-mind that for failures occurring at arbitrary effector positions, the planar fit will usually yield only an approximate value of the pitching moment and therefore, only an approximate range of trimmable angle of attack can be estimated. Accuracy could be improved by using more data points in the least squares fit of the plane to the surface. Alternately a more complex set basis functions could be fit to the surface; however, this would require more complex methods to establish the boundaries of the AMS [3], [4] In any case, the surface equation would be

Effector failure case	Benchmark algorithm	NLAMS algorithm
1. Flaps locked at $26^\circ$	$0 \leq \alpha \leq 4$	$0 \leq \alpha \leq 4$
2. Flaps floating ( $0^\circ$ )	$13 \leq \alpha \leq 50$	$15 \leq \alpha \leq 50$
3. Flaps locked at $-15^\circ$	$\alpha = [\emptyset]$	$\alpha = [\emptyset]$
4. Right Elevon Inner locked at $25^\circ$ and Left Elevon Outer locked at $-30^\circ$	N/A (Non-symmetric)	$0 \leq \alpha \leq 50$

Table 1. Comparison of benchmark and NLAMS results

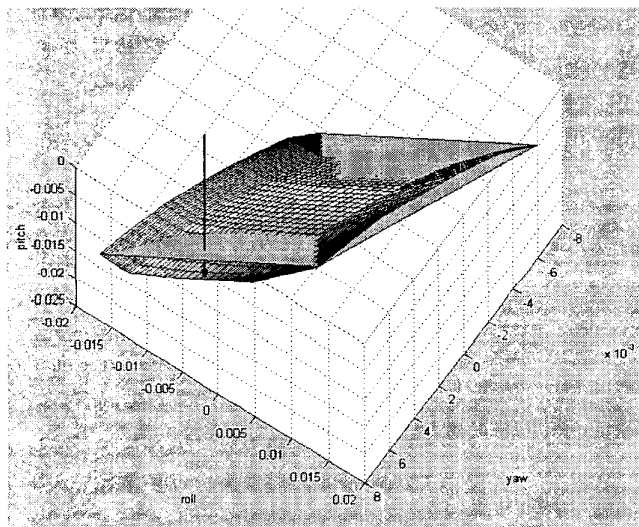

Figure 9. 3-D figure in moment space showing pitching moment intercept error

more representative of portions of the AMS boundaries. The difference between a planar fit and a portion of the surface of the re-entry vehicle AMS is illustrated in Figures 9 and 10.

Figure 10 is a magnification of Figure 9 in the region where the moment vector intersects the boundary surface. From Figure 10, the computed maximum attainable pitching moment intersects the planar surface at a different point than the nonlinear surface. Thus, a pitching moment error is introduced that will result in an error in the estimated range of the trimmable angle of attack. Three possible results can occur

due to the surface discrepancies.

1. If the moment vector  $D$  intersects the best-fit plane and the nonlinear AMS boundary where points on the nonlinear surface and facet plane are coincident, then one obtains an exact value for the range of  $\alpha$  where the vehicle can be trimmed.
2. If the moment vector  $D$  intersects the best-fit plane before the nonlinear AMS boundary, then one may conclude that the range of  $\alpha$  for which the vehicle can be trimmed is conservative. In other words, the actual range of  $\alpha$  is greater than the one obtained using the NLAMS algorithm.
3. If the moment vector  $D$  intersects the nonlinear AMS boundary first, then one may conclude that the range of  $\alpha$  where the vehicle can be trimmed is overestimated, i.e., the actual range of  $\alpha$  is smaller than the obtained one using the NLAMS algorithm.

### 5. Conclusions

A method is presented for computing the trimmable range of angle of attack for air vehicles experiencing control effector failures. Types of failures considered include floating effectors that do not contribute to the vehicle aerodynamic forces and moments as well as effectors locked at a given position within the effector displacement range. The algorithm can be used to provide critical information to online trajectory generators or path planners for autonomous air vehicles. The NLAMS algorithm will be incorporated in an online footprint trajectory generator algorithm as part of a research project ongoing at Wright Patterson Air Force Base.

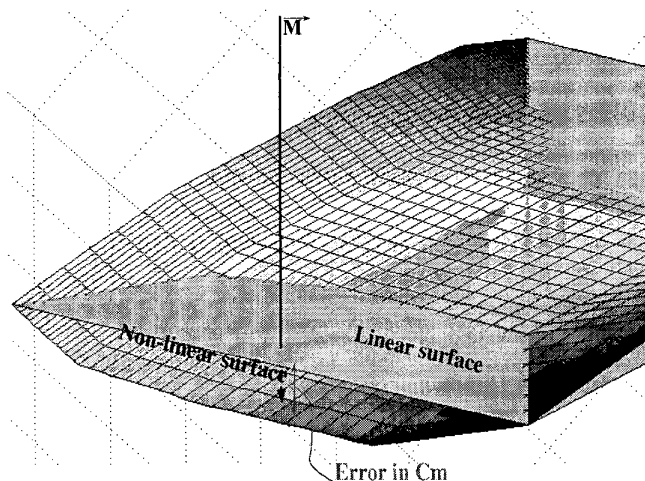

**Figure 10.** A detailed figure showing the pitching moment intercept error



**David B. Doman** is a Senior Aerospace Engineer at the Control Theory and Optimization Branch, Control Sciences Division, at the Air Force Research Laboratory at Wright Patterson AFB, OH. He is the Technical Area Leader for the Space Access and Hypersonic Vehicle Guidance and Control Team at AFRL. He is also an Associate Editor for the AIAA Journal of Guidance, Control and Dynamics. He holds a Ph.D. degree in Aerospace Engineering from Virginia Tech and is a Senior Member of the AIAA and a Member of IEEE.

## References

- [1] W. Durham, "Attainable moments for the constrained control allocation problem," *Journal of Guidance, Control and Dynamics*, vol. 17, no. 6, pp. 1371–1373, 1994.
- [2] W. Durham, "Constrained control allocation: Three moment problem," *Journal of Guidance, Control and Dynamics*, vol. 16, no. 4, pp. 717–725, 1993.
- [3] D. B. Doman and A. G. Sparks, "Concepts for constrained control allocation of mixed quadratic and linear effectors," in *Proceedings of the 2002 American Control Conference, ACC02-AIAA1028*, May 2002.
- [4] M. Bolender and D. B. Doman, "A method for the determination of the attainable moment set for non-linear control effectors," in *Proceedings of the 2003 IEEE Aerospace Control Conference, IEEEAC 1192*, March 2003.



**Joseph Kaloust** is an Associate Professor in the Department of Engineering at Hope College in Holland, MI. He holds a Ph.D. degree in Electrical Engineering from The University of Central Florida. Before joining the faculty of Hope College, Dr. Kaloust was employed by Lockheed-Martin where he was awarded two patents on stall and recovery systems for air vehicles operating at high angles of attack.