

Determination of Low Energy (<160 keV) X-Ray Spectra and Verification of Transport Calculations Through Silicon

J. R. Turinetti¹, K. L. Critchfield¹, J. R. Chavez¹, W. T. Kemp¹, R. D. Bellem², and D. E. Beutler³

¹Phillips Laboratory, 3550 Aberdeen Ave SE, Kirtland AFB, NM 87117-5776

²Embry-Riddle Aeronautical University, 3200 Willow Creek Rd, Prescott, AZ 86301

³Sandia National Laboratories[†], PO Box 5800, Albuquerque, NM 87185-1179

Abstract

X-ray spectroscopy discrepancies at measured energies below 50 keV are shown through ITS detector response calculations to be caused by germanium K edge escape peak losses. Accounting for this detector response, CEPXS/ONELD transport calculations through silicon agree well with measurements.

I. INTRODUCTION

LEXR (Low Energy X-Ray) is a large shielded x-ray test cell that can illuminate entire electronic assemblies at the USAF Phillips Laboratory, Kirtland Air Force Base. The radiation source for LEXR is a Philips Model MCN 165 x-ray unit with a tungsten target and input power levels up to 3.6 kW. LEXR provides ionizing-radiation dose rates up to 2500 rad(Si)/s with spectral end-point energies between 8 and 160 keV. LEXR was developed to perform ionizing radiation research and evaluation of microelectronic and photonic devices, circuits, and subsystems in accordance with the methods outlined in ASTM F-1467. [1] Studies of this facility have been reported in previous publications. [2, 3] The purpose of these previous and current studies is to characterize and calibrate the LEXR facility.

In the past there has been a problem of measuring x-ray spectra below 50 keV and comparing them to transport calculations. [4] Work at Sandia National Laboratories showed an order of magnitude difference between Monte Carlo calculations and measurements at these low energies [4], but with much higher endpoint energies. Previous measurements of the LEXR spectrum have shown a hump at energies measured below 8 keV. This low energy hump is a contribution to the LEXR spectrum, shaped like a hump or mound, that is not expected.

This work presents two new advances. First, the low energy hump is shown to be a result of the germanium K edge escape peak losses and can be accounted for by incorporating the detector response into the measurements. Escape peak losses are usually overshadowed by Compton scatter, but this work shows that escape peak losses need to be accounted for at very low endpoint energies. Second, CEPXS/ONELD was

found to accurately predict the LEXR spectrum through silicon. After accounting for the response of the detector, the comparisons between calculation and measurement were shown to agree to within 5% for each energy interval.

II. EXPERIMENTAL SETUP

A high resolution EG&G ORTEC x-ray spectrometry system was used to measure differential energy deposition. In general, the differential energy deposition can be related to the energy spectrum. This system is made up of a cryogenically cooled high-purity germanium (HPGe) planar detector, a high count-rate preamplifier, and a computer controlled multi-channel pulse-height analyzer.

The HPGe detector was placed 82 cm from the x-ray tube with three collimators placed in between. These small aperture collimators combined with low filament currents on the x-ray tube prevented saturation of the detection system. [2] This setup is shown in Figure 1. The silicon wafer was placed between the third collimator and the detector for some measurements.

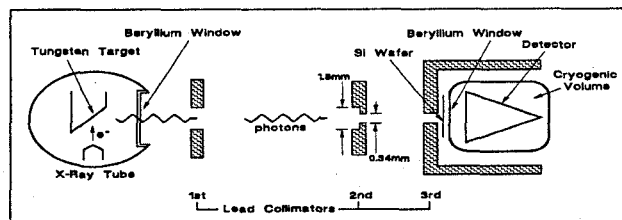

Figure 1: Experimental setup.

III. SPECTRA DETERMINATION

To resolve the low energy hump, measurements of the LEXR pulse-height distribution were first made with a silicon wafer in front of the detector. The response of the detector was then modeled by transport calculations. These results were compared with each other and to published data on detector responses [5] to determine the cause of the low energy hump. Once the hump was resolved, transport calculations could be confidently used to characterize the entire spectrum.

[†]Sandia is a multiprogram laboratory operated by Sandia Corporation, a Lockheed Martin Company, for the U.S. Department of Energy under Contract DE-AC04-94AL85000.

A. Spectra Calculations

It is important to incorporate the detector response when trying to find the true spectrum. What the detector measures and what the actual spectrum is can be entirely different.

The detector response had not been explicitly calculated before to resolve the low energy hump because the two main concerns of response were satisfied. First, the measurements were in the region where the response of the detector was independent with energy. Second, as will be shown later, Compton scattering is not an issue at these very low energies. What was not accounted for were the less likely concerns, particularly escape peak losses.

1) Theory

The response function (R) relates the measured pulse-height distribution (Φ) to the incident spectrum (Ψ). The relationship between these three quantities is shown in equation 1.

$$\Phi = R \cdot \Psi \text{ or } \Psi = R^{-1} \cdot \Phi \quad (1)$$

The key to this calculation is knowing the response function. The response function is a matrix containing the measured pulse-height distributions for a known incident spectrum over the entire energy range of measurements.

For example, one column of the response matrix would be the measured pulse-height distribution for an incident flat spectrum of photons between 15 and 20 keV. The next column of the response matrix would be the measured pulse-height distribution for an incident flat spectrum of photons between 20 and 25 keV, and so on.

The problem is that producing an incident flat spectrum between 15 and 20 keV is very difficult. So what has been done here is to use a computer code to simulate the incident spectrum and the detector.

The response matrix was divided into energy intervals or bins to provide greater resolution near the low energies and the K and L edge lines. The bins went in steps of 1 keV from 1 to 15 keV, in steps of 5 keV from 15 to 55 keV, in steps of 2 keV from 55 to 75 keV, and in steps of 5 keV from 75 to 160 keV. This binning is not close to the resolution of the detector, but is small enough so as not to distort the shape of the spectra.

The HPGe detector was modeled from schematics obtained from EG&G ORTEC for our particular detector. To save on calculational resources the model was simplified from that given by EG&G ORTEC. Also included in the model was lead shielding that was placed around the detector.

2) Computer Code

The ACCEPTP code of the ITS Monte Carlo software package was used to calculate the response matrix. [6] The ACCEPTP code is a general three dimensional transport code that follows photons and electrons down to 1 keV. It was run on a Sun Ultra Unix workstation. The number of histories for each energy bin was set to give a statistical standard error of ten percent or less.

For the calculation of the response matrix, the ACCEPTP code was chosen for three main reasons. First, this is a calculation that only needs to be done one time, so the expense in time could be afforded for Monte Carlo. Second, the three dimensional transport could be important for an accurate modeling of the system. Third, ACCEPTP offers the ability to tally the pulse-height distribution per incident particle which is the exact quantity needed.

B. Spectra Results

The first step in determining the true spectra is to determine the cause of the low energy hump. An example of the hump in a pulse-height distribution is given in Figure 2. This is the measured pulse-height distribution of a 18 keV endpoint energy spectrum transmitted through a silicon wafer. For the area below 8 keV, a hump occurs where one would expect no counts. As the endpoint energy is decreased from 18 to 14 keV, Figures 2-4, the low energy hump has an endpoint of around 10 keV less than the pulse-height distribution endpoint energy. For later comparison, the hump in Figure 2 is approximately 18% of the primary photons in the 11 to 13 keV range.

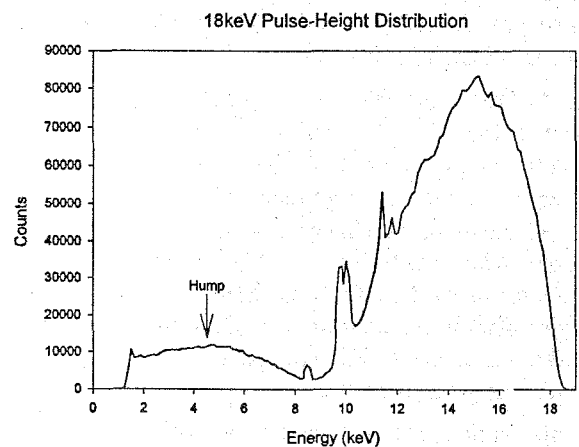

Figure 2: 18 keV endpoint measured pulse-height distribution through Si.

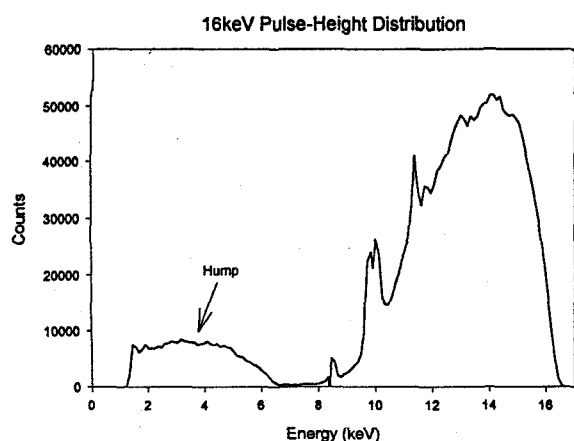

Figure 3: 16 keV endpoint measured pulse-height distribution through Si.

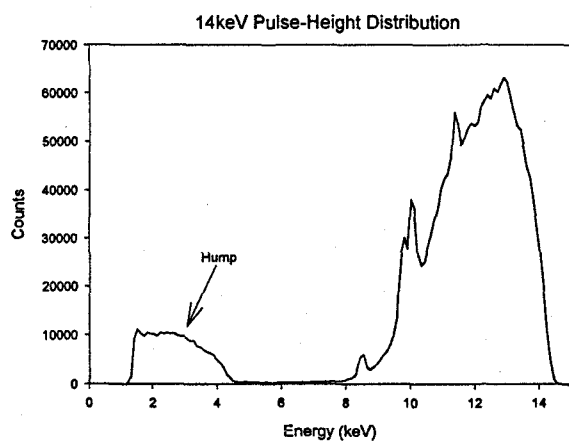

Figure 4: 14 keV endpoint measured pulse-height distribution through Si.

Using the model of the detector and the ACCEPTP codes, the response of the detector to a flat spectrum between 11 and 13 keV is shown in Figure 5. This response has a reflection of the input spectrum 10 keV below the original and is roughly 18% that of the incident spectrum.

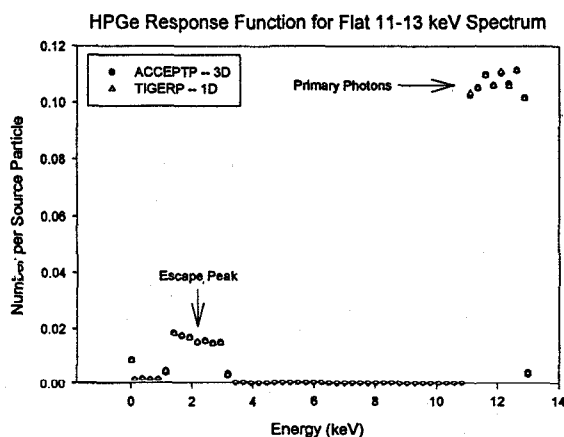

Figure 5: Detector response to a flat 11-13 keV spectrum.

Also shown in Figure 5 is the same detector response to a flat spectrum between 11 and 13 keV, but calculated by TIGERP. TIGERP is the one dimensional code of the ITS software package. [6] The two calculations appear to be the same. This illustrates that the source of the low energy hump could be understood by using TIGERP, but to ensure that three dimensional effects are not a problem, the ACCEPTP code is used to calculate the complete detector response.

From previous work done on detector response [5], the weighted average energy of the fluorescent x-rays is 10.0 keV and at the K edge the losses are 18% for germanium. The weighted average energy is the amount that is subtracted from the incident x-rays. Comparing these two quantities given in Ref. 6 with the measured and calculated quantities found in this experiment, we are convinced that the low energy hump is due to the germanium K edge escape peak losses.

To be sure this was the only cause of the low energy hump, measurements were conducted investigating other explanations. These measurements determined that dark current noise, backscatter from the LEXR facility walls, and Compton backscatter from detector instrumentation were not responsible for the hump.

Compton scatter inside the detector was found not to be the cause of the low energy hump by the equation for maximum Compton scattering [7].

$$E_{\max} = hv \left(\frac{2hv / m_0 c^2}{1 + 2hv / m_0 c^2} \right) \quad (2)$$

From this equation, it can be seen that the Compton continuum would start at 0.73, 0.94, or 1.18 keV for 14, 16, or 18 keV x-rays, respectively. This rules out Compton interactions as the cause of the low energy hump.

The realization that edge losses occur is not a new discovery. [5] This work illustrates that it is essential to take escape peak losses into account when determining the true spectra of the LEXR facility. Also shown, especially in Figure 5, is that the ACCEPTP code can account for the escape peak losses.

Knowing that the ACCEPTP code can handle the escape peak losses, it is used to develop the response function. Measurements were then taken using the LEXR spectrum to obtain the pulse-height distribution. This pulse-height distribution was adjusted with the response function according to equation 1, using the Mathcad[®] computer program, to obtain the corrected spectrum. Some of these measured spectra are shown in Figures 6, 7, and 8 for endpoint energies of 20, 50, and 80 keV. These energies were chosen centered around 50 keV because testing in the LEXR is done at 50 keV.

Figures 6, 7, and 8 show how the energy spectrum is changed by incorporating the detector response. The two main changes are at the low energies. The energy bins with the K edge lines are increased a few percent, and the low

energy bins ramp down and become negligible sooner. These are important changes from a modeling perspective.

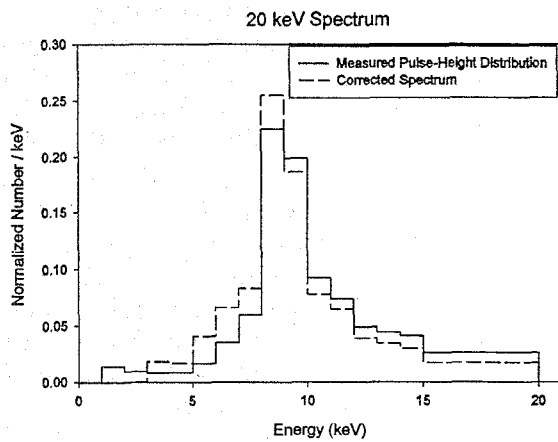

Figure 6: 20 keV binned comparison of measured pulse-height distribution and corrected spectrum.

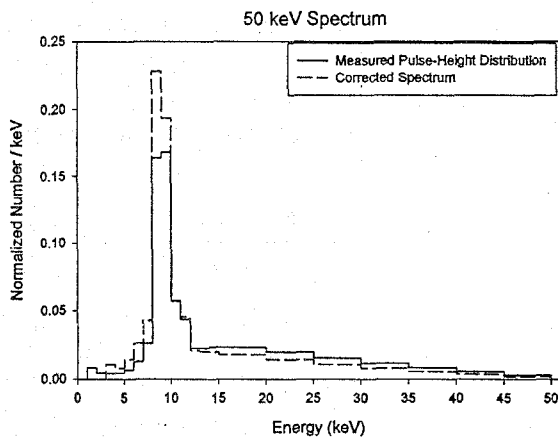

Figure 7: 50 keV binned comparison of measured pulse-height distribution and corrected spectrum.

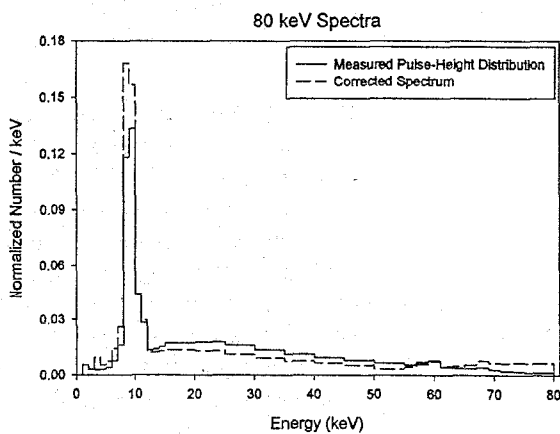

Figure 8: 80 keV binned comparison of measured pulse-height distribution and corrected spectrum.

IV. TRANSPORT VERIFICATION

For device testing using the LEXR, it is important to be able to model the radiation through the device under test. A quick computer code would be suitable for this purpose. Silicon is used as a good sample material used in electronics for verifying the code.

A. Transport Calculations

The calculations used to verify the transport code are relatively straightforward. They are comparisons of calculated data and measured data.

1) Theory

The verification of the computer code involved measuring x-ray pulse-height distributions with (Φ_{Si}) and without (Φ) silicon in front of the detector. The measured pulse-height distributions were then adjusted for the response (R) of the detector to get the corrected spectra with (Ψ_{Si}) and without (Ψ) silicon. Next, the corrected spectra without silicon were used as inputs for transport calculations through the silicon to get calculated spectra through silicon (Γ_{Si}). Finally, the calculated spectra through silicon were compared to the corrected spectra through the silicon. This process is shown as a schematic in Figure 9.

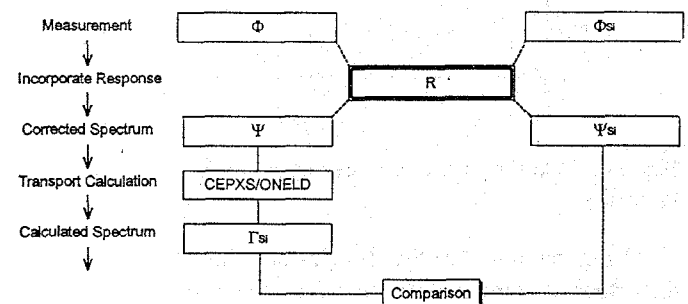

Figure 9: Process schematic.

2) Computer Code

The CEPXS/ONELD code was used to calculate the x-ray spectrum through silicon. [8] The CEPXS/ONELD code is a discrete ordinates code package for solving one-dimensional coupled electron-photon transport down to 1 keV. It was run on an IBM RISC 6000 UNIX workstation.

For the modeling of a device under test, the CEPXS/ONELD code was chosen for three main reasons. First, this calculation needs to be done many times for all the different devices tested, so the quick results of discrete ordinates methods are important, as compared to the Monte Carlo ACCEPTP code. Second, only one dimensional transport is required for the filtered spectrum analysis of device testing. Third, CEPXS/ONELD has been shown to handle very well the dose enhancement that may occur in many devices [9], as compared to other photon-only discrete ordinates codes.

B. Transport Results

Measurements of the x-ray pulse-height distributions were first made with and without a silicon absorber in front of the detector. These results are shown for 20 keV in Figure 10, for 50 keV in Figure 11, and for 80 keV in Figure 12.

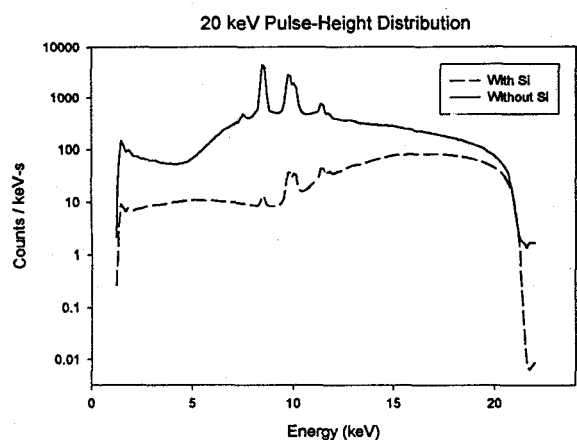

Figure 10: 20 keV measured pulse-height distributions with and without Si.

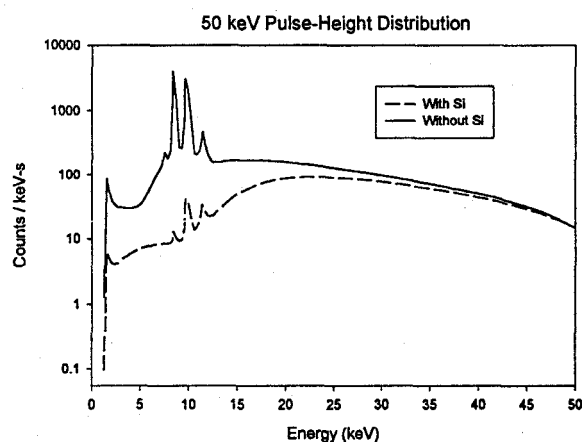

Figure 11: 50 keV measured pulse-height distributions with and without Si.

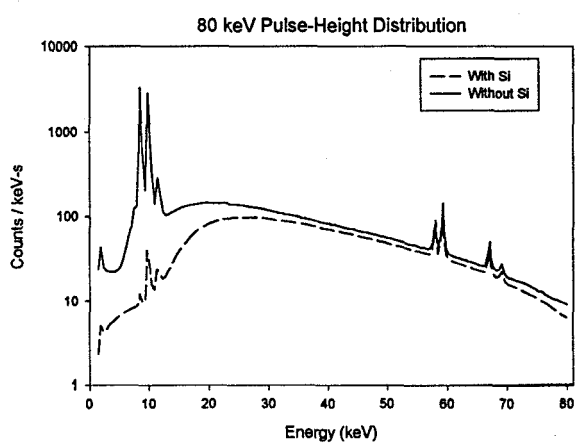

Figure 12: 80 keV measured pulse-height distributions with and without Si.

The response function of the detector was applied to the measured pulse-height distribution to give a corrected spectrum at 20, 50, and 80 keV. These corrected spectra were used as input to CEPXS/ONELD to calculate the spectra through the silicon. The measured pulse-height distributions, the corrected spectra, and the calculated spectra (all through silicon) for 20, 50, and 80 keV are compared in Figures 13, 14, and 15, respectively.

The CEPXS/ONELD calculations show good agreement with the corrected spectrum, when compared to the measured pulse-height distribution at low energies. The comparisons agree to within 5% per energy interval over the entire spectrum. Errors between the corrected spectrum and the calculated spectrum were determined by normalizing each energy spectrum to one and doing a bin to bin comparison. This shows that CEPXS/ONELD can predict the x-ray spectrum through materials for the LEXR facility.

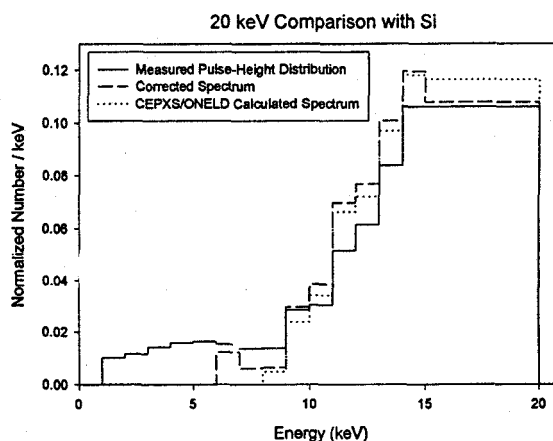

Figure 13: 20 keV binned comparison of measured pulse-height distribution, corrected spectrum, and CEPXS/ONELD calculated spectrum.

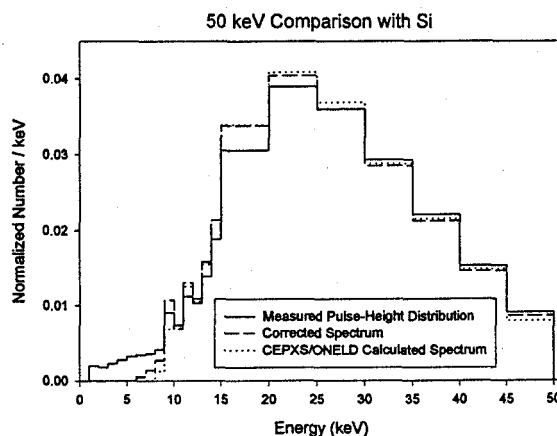

Figure 14: 50 keV binned comparison of measured pulse-height distribution, corrected spectrum, and CEPXS/ONELD calculated spectrum.

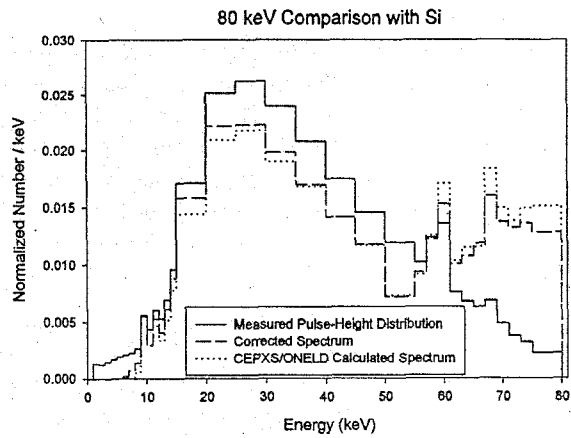

Figure 15: 80 keV binned comparison of measured pulse-height distribution, corrected spectrum, and CEPXS/ONELD calculated spectrum.

V. CONCLUSIONS

The low energy hump that has hindered the comparison of transport code calculated spectra with measured pulse-height distributions at the LEXR facility is caused by escape peak losses from the K edge of germanium. It was found that the ACCEPTP code of the ITS software package will accurately predict these escape peak losses. Therefore, use of this code for the response of our detector along with the measured pulse-height distribution will result in the true LEXR spectrum. These escape peak losses are usually neglected because of the dominance of Compton scattering [4], but we show that at very low energies they must also be accounted for.

With the low energy hump resolved, the validation of the LEXR facility now includes the ability to use CEPXS/ONELD to predict the x-ray spectrum through materials. Calculations through silicon are within 5% of the true spectra through silicon. This, along with previous LEXR work [2, 3], expands our understanding of the LEXR spectrum and shows that it can be very accurately modeled.

One item for future consideration is to verify CEPXS/ONELD predictions for LEXR spectra through more materials, particularly lead and aluminum.

VI. REFERENCES

- [1] ASTM Standard F1467 *Std. Guide for the Use of an X-Ray Tester (10keV) in Ionizing Radiation Effects Testing of Microelectronic Devices*.
- [2] R.W. Tallon, D.C. Koller, R.M. Pelzl, R.D. Pugh, R.D. Bellem, "5 to 160 keV Continuous-Wave X-Ray Spectral Energy Distribution and Energy Flux Density Measurements", *IEEE Trans. Nucl. Sci.* **NS-41**, 2112 (1994).
- [3] R.D. Bellem, K.L. Critchfield, R.M. Pelzl, R.D. Pugh, R.W. Tallon, "Analytical and Experimental Dosimetry Techniques for Calibrating a Low Energy X-Ray Radiation Source", *IEEE Trans. Nucl. Sci.* **NS-41**, 2139 (1994).
- [4] D.E. Beutler, J.A. Halbleib, D.P. Knott, "Comparison of Experimental Pulse-Height Distributions in Germanium Detectors with Integrated-Tiger-Series-Code Predictions", *IEEE Trans. Nucl. Sci.* **NS-36**, 1912 (1989).
- [5] H.I. Israel, D.W. Lier, E. Storm, "Comparison of Detectors used in Measurement of 10 to 300 keV X-Ray Spectra", *Nucl. Inst. And Meth.*, **91**, 141 (1971).
- [6] J. A. Halbleib and T. A. Mehlhorn, "ITS: The Integrated TIGER Series of Coupled Electron/Photon Monte Carlo Transport Codes", SAND84-0573, Sandia National Laboratories, November 1984.
- [7] G. F. Knoll, "Radiation Detection and Measurement", John Wiley & Sons, 1989.
- [8] L. J. Lorence, Jr., "CEPXS/ONELD Version 2.0: A Discrete Ordinates Package for General One-Dimensional Coupled Electron-Photon Transport, *IEEE Trans. Nucl. Sci.*, Vol **NS-39**, 1031 (1992); L. J. Lorence, Jr., J. E. Morel, G. D. Valdez, "User's Guide to CEPXS/ONEDANT: A One-Dimensional Coupled Electron-Photon Discrete Ordinates Code Package Version 1.0", SAND89-1661, Sandia National Laboratories, September 1989.
- [9] J. C. Garth, K.L. Critchfield, J. R. Turinetti, D. E. Beutler, "A Comprehensive Comparison of CEPXS/ONELD Calculations of Dose Enhancement with the Co-60 Data Set of Wall and Burke", *IEEE Trans. Nucl. Sci.* **NS-43**, 2731 (1996).