

AIRCRAFT DESIGN AND SYSTEMS GROUP (AERO)

Aircraft Cabin Air and Engine Oil

– A Systems Engineering View

Dieter Scholz

Hamburg University of Applied Sciences

(with backup slides and update)

Hamburg Aerospace Lecture Series (HALS)

DGLR, RAeS, VDI, ZAL, HAW Hamburg together with VC and UFO

Hamburg, 27th April, 2017

<https://doi.org/10.5281/zenodo.1237858>

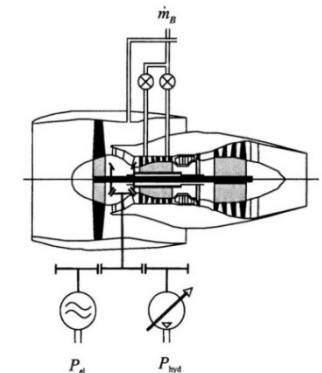
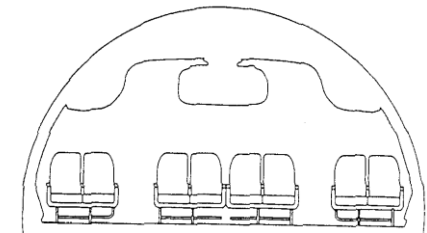

Abstract

Purpose – This presentation gives an introduction to aircraft cabin air quality and contamination risks. Beyond these fundamentals, most of the current engineering issues discussed with respect to the topic are explained.

Design/methodology/approach – The literature review is complemented with own explanations, thoughts and derivations.

Findings – There is a real health and flight safety risk due to contaminated cabin air. For the infrequent flyer the risk is very low. Also aviation statistics are not dominated by cabin air related accidents. Nevertheless, a bleed air based air conditioning system can be regarded as applying a fundamentally wrong systems engineering approach. Measures have to be taken.

Research limitations/implications – This review study is based on references. Own measurements have not been made.

Practical implications – Passengers and crew are made aware of the risk of cabin air contamination based on technical facts. Steps towards a solution of the problem are presented as they can be applied by passengers, pilots, airlines and manufacturers respectively.

Social implications – Better knowledge of the problem should enable passengers and crew to maintain a firm position in the sometimes heated discussion.

Originality/value – Engineering based information with a critical view on the topic seems to be missing in public. This presentation tries to fill this gap.

© This work is protected by copyright

The work is licensed under a Creative Commons Attribution-NonCommercial-ShareAlike 4.0 International License: CC BY-NC-SA
<http://creativecommons.org/licenses/by-nc-sa/4.0>



Any further request may be directed to Prof. Dr.-Ing. Dieter Scholz, MSME
E-Mail see: <http://www.ProfScholz.de>

Aircraft Cabin Air and Engine Oil – A Systems Engineering View

Contents

- Introduction
- Jet Engine Oil
- Cabin Comfort and Cabin Air Quality
 - Health and Flight Safety Implications
 - Certification Requirements
- Air Conditioning Technology
- Jet Engine
- Auxiliary Power Unit (APU)
- Engineering Design Principles for Air Conditioning from SAE
- How much Oil Gets into the Cabin?
- Carbon Monoxide (CO) in the Cabin
- Engine Oil Detected on its Way into the Cabin
- Measures in Aircraft Operation / Hints for Pilots
- Solutions
- Contact

Introduction

MEDICAL INVESTIGATION DAVID LEARMOUNT LONDON

Cabin air killed BA pilot, say experts

Authority on organophosphate poisoning says tissue from Richard Westgate, who died in 2012, “worst case” he has seen

Sustained exposure to organo-phosphates (OP) from contaminated cabin air contributed to the death of a 43-year-old British Airways pilot, a group of medical experts believe.

Their findings are likely to increase pressure on the industry to take more seriously the issue of sustained exposure to engine bleed air. Airlines and governments have dismissed suggestions that it can be a factor behind flightcrew falling ill.

The pilot, senior first officer Richard Westgate, started flying professionally in 1996 and

medical details of his symptoms before death are on record.

Although no coroner’s inquest has been held into his death, medical experts led by Prof Mohamed Abou-Donia of Duke University Medical School, North Carolina, the world’s leading authority on organophosphate poisoning, have just published a study into two autopsies carried out on Westgate, who until his illness was a slim, fit paragliding champion.

Abou-Donia and his colleagues are also investigating the death this year of an unnamed 34-year-old BA airline steward, whose



Westgate: series of symptoms

by far.” He adds: “The air transport industry constantly over-

cabin, but they – and aircraft manufacturers – maintain that this is at a harmless level. Abou-Donia argues this was not so in Westgate’s case, despite the fact that the pilot had never logged an actual “fume event” during his career.

WATERSHED

Frank Cannon, the lawyer acting for the families of both deceased, says the Westgate case is a watershed in this controversy: “They can try explaining one [case] away, but not another and then another.” Cannon says he has “about 50” cases on his books.

■ ■ ■

(Flight International 2014)

Introduction

... but ...

The Telegraph

By **Telegraph Reporters**

13 APRIL 2017 • 3:23PM

The family of a British Airways co-pilot who believed he had been poisoned by contaminated cockpit air have accused the airline industry of having its "head in the sand" over the issue.

Richard Westgate, 43, died in December 2012 after moving to the Netherlands to seek help from a specialist clinic for his symptoms which he thought were caused by "aerotoxic syndrome", which has been called "pilot's disease".

A coroner ruled Mr Westgate died accidentally at the Bastion Hotel in Bussum, Netherlands after taking an unintentional overdose of the sleeping tablet pentobarbital.

(Telegraph 2017)

A controversial issue!

Jet Engine Oil

warning:

contains **TCP**
tricresylphosphate.
Swallowing this product
can cause nervous
system disorders,
including paralysis.
Prolonged breathing of oil
mist, or prolonged or
repeated skin contact can
cause nervous system
effects.

(Cannon 2016)

Judging Jet Engine Oil Based on Warnings Given by Manufacturer

ExxonMobil

Material Safety Data Sheet (MSDS)

FIRST AID MEASURES, INHALATION

Remove from further exposure [*in a fume event?*]... Use adequate respiratory protection [*not available for passengers!*]. If respiratory irritation, dizziness, nausea, or **unconsciousness** occurs, seek immediate medical assistance. If **breathing** has **stopped**, assist ventilation with a mechanical device or use mouth-to-mouth **resuscitation**.

(Exxon 2016c)

This warning was changed in 2004 (Michaelis 2012) to:

"This product is **not** expected to produce adverse **health effects** under normal conditions of use ... Product may decompose at elevated temperatures ... and give off irritating and/or **harmful ... gases/vapours/fumes**. Symptoms from acute exposure to these decomposition products **in confined spaces [aircraft cabin]** may include **headache, nausea, eye, nose, and throat irritation**."

(Exxon 2016c)

Jet Engine Oil

Tricresyl Phosphate (TCP)

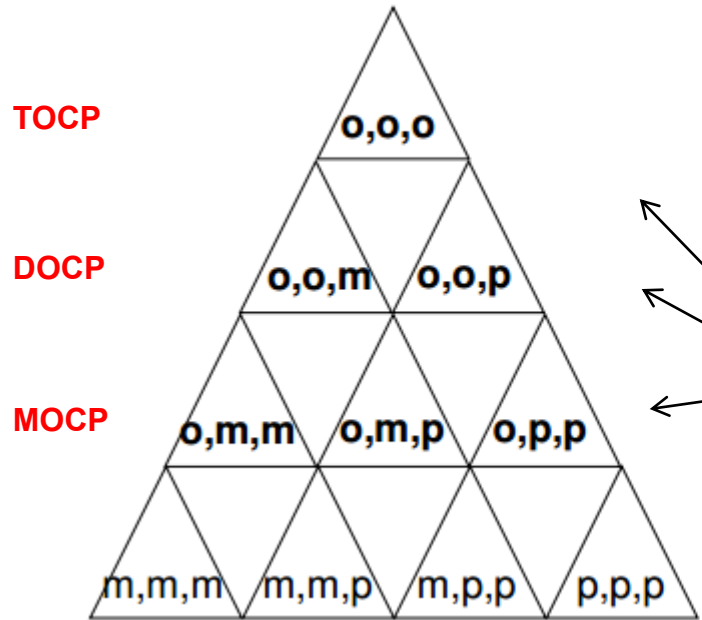

TOCP

DOCP

MOCP

T = tri (3)
D = di (2)
M = mono (1)

o ortho-cresyl group

m meta-cresyl group

p para-cresyl group

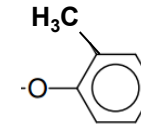

OC

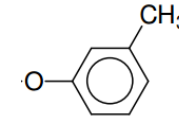

MC

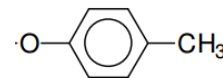

PC

ortho-cresyl group containing molecules are highlighted in **bold**, they are the *toxic isomers*.

TOCP:

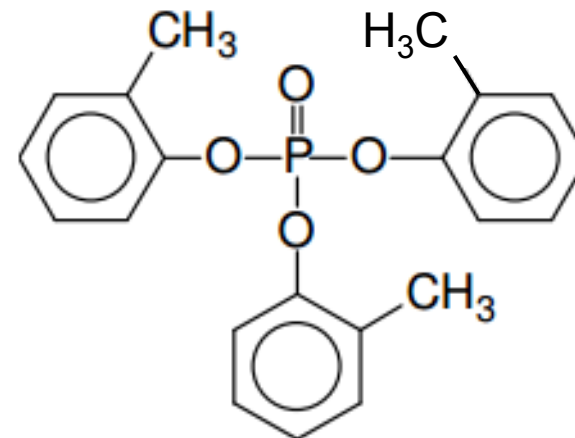

(Winder 2001)

Jet Engine Oil

TCP Toxicity Basics

Winder 2001 / Henschler 1958

- The **10 isomers** that make up **TCP** are toxicologically different.
- The ortho containing isomers are toxic, without ortho isomers are not toxic (Henschler 1958).
- Most infamous and most studied: TOCP (tri-ortho-cresyl phosphate).
- Other ortho containing isomers in TCP are **more neurotoxic than TOCP**:
 - **DOCP** (di-ortho-cresyl phosphates): **5** times more neurotoxic ($TEF = 5$),
 - **MOCP** (mono-ortho-cresyl phosphates): **10** times more neurotoxic ($TEF = 10$).
- DOCP and MOCP are present in the engine oil in **higher concentration** than TOCP.
- Based on **concentration** (C_i in ppm) and **relative neurotoxicity** (toxic equivalency factor, TEF) for each isomer an equivalent TOCP toxicity (TEQ) can be calculated. The base unit of the equivalent TOCP toxicity is proposed to be that of 1 ppm ($\approx 1\text{mg/l}$) of TOCP in the oil. $TEQ = \sum C_i \cdot TEF_i$.
- Winder calculates this **equivalent TOCP toxicity**, considering the presents of all ortho isomers:
TEQ for Mobil Jet Oil II: 30730
(The TEQ of this oil would be less than 1 if only TOCP would be present and no other ortho isomers! Therefore, ignoring the DOCP and MOCP content of the oil yields highly inaccurate results.)
TEQ for Mobil 291: 17606

Jet Engine Oil

TCP Toxicity Basics

Henschler 1958

- TCP toxicity is found from animal poisoning with hens and cats.
- Results obtained from these test animals can be applied to humans (with caution).
- TOCP acts on the peripheral nerves and causes predominantly atonic peripheral paralysis.
- MOCP and DOCP act rather on the brain and on the spinal cord. This leads to spastic paralysis.
- If the content of TOCP, DOCP, and MOCP is known, calculation of TEQ is directly possible (see previous page).
- If only the total ortho cresyl (OC) content q in the TCP is known, the toxic equivalency factor, TEF can be calculated based on a purely statistical distribution of the 10 isomers (as Henschler shows). It is easy to understand:

- At 0% of OC neither of MOCP, DOCP, nor TOCP are present: $TEF = 0$
- At 100 % of OC only TOCP would be present and $TEF = 1$ by definition.

- The theoretical formula (blue) is with $TEF(\text{TOCP}) = 1$:

$$TEF = 16q^3 - 45q^2 + 30q$$

- According to Henschler this curve needs to be adapted to fit his experimental results (red). An equation to fit this experimental curve would be (purple):

$$TEF = 330q^2 \quad \text{valid for } q < 0,13$$

and can be applied to typically low OC content.

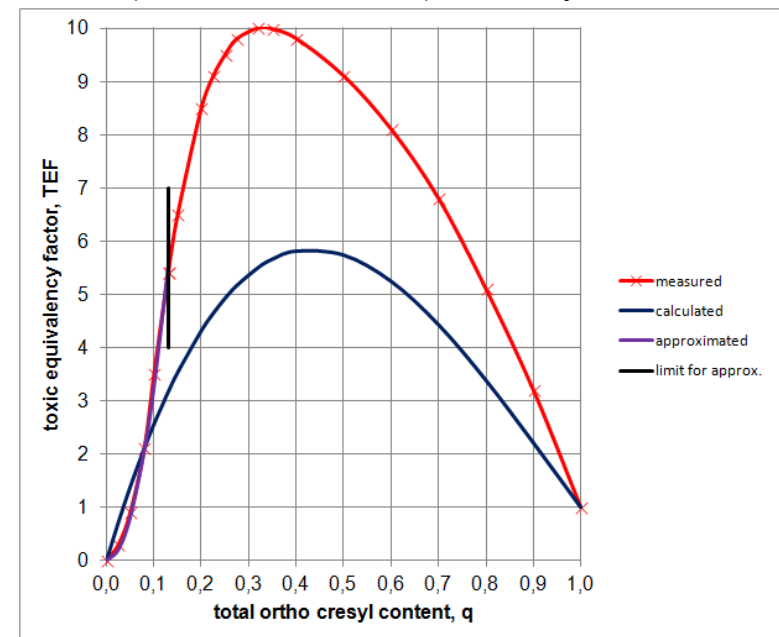

Jet Engine Oil

Jet Engine Oil Content

Winder 2001

Jet engine oil contains:

- 95 % synthetic esters (pentaerythritol and dipentaerythritol)
- 3 % tricresyl phosphate (TCP) (neurotoxin)
- 1 % phenyl-alpha-naphthylamine (PAN) (carcinogen)
- Benzamine
- unknown substances (this can be e.g. unknown other OPs or "impurities")

In jet oil, TCP is used as an anti-wear additive to enhance load bearing properties and improve tolerance to increasing speed of rotating or sliding motion. The anti-wear properties of TCP are considered unique.

OHRCA 2014

TCP isomer patterns observed in nine engine oils were comparable. The concentration within the TCP:

mmp: 49 %, mmm: 29%, mpp: 22 %, ppp: 0,2 %.

Among the nine engine oils were Aeroshell 560, BP 2389 and BP2197. The concentration within their TCP:
ooo: 0.01%.

De Nola 2008

9 out of the 10 TCP isomers were found (Remark: missing was probably the ppp isomer). Concentrations were found for ...

ooo: no

oom: no

oop: yes

omm, omp: 13 mg/l ... 150 mg/l in the oil. This is 0,04 % ... 0,5 % of the TCP. TEQ = 130 ... 1500

omp: low concentration

opp: no

Jet Engine Oil

Jet Engine Oil Content

Ramsden 2013 / Imbert 1997

Another possibility is that isomerization of the TCP takes place within the engine during operation [after pyrolysis]. Investigations on the isomerization of cresol at 380 °C using a solid phase catalyst resulted in an equilibrium composition of 36% ortho, 48% meta and 16% para.

Remark: According to Henschler 1958 (see above) this leads to TEF ≈ 10 and with 3 % TCP would be 10,8 g OC or 10800 ppm, TEQ = 108000.

Ramsden 2013a

OC content in the TCP:

TCP Class 1: 30% (about 1930)

TCP Class 2: ?

TCP Class 3: 3% (about 1958, "modern TCP")

TCP Class 4: 0.3 % (since 1992, "conventional TCP")

TCP Class 5: $\approx 0,03$ % (since 1997, "low-toxicity TCP")

Calculation: Today with 3% TCP in the oil of which is 0% TOCP but possibly 0,03% MOCP (= 900 mg = 900 ppm) yields a TEQ of 9000.

EASA 2017b

Based on the analysis in the original oils it was found that in all oils the tri(m,m,m,-), tri(m,m,p)-, tri(m,p,p)- and tri(p,p,p)-cresyl phosphate were detected. Tri(o,o,o)-cresyl phosphate was not detected in the oils.

Remark: Other ortho isomers seem not to be part of the investigation, but would be important.

The mass percentage of TCP calculated from the analysis of the oils corresponds with the oil specifications described in the MSDS sheets from the suppliers.

Remark: Exxon fails to report about the ortho isomer content in the TCP and EASA 2017b does not comment on it.

Based on the analysis of the oil vapours it was found that the four isomers of TCP were detected in all oil vapours in the same composition as was found for the original oils. Tri(o,o,o) cresyl phosphate was not detected in the oil vapours.

Only the company NYCO SA produces jet engine oil without TCP. Its product Turbonyciol 600 contains triphenylphosphate (TPhP) or triisopropyl phenyl phosphate (TIPP) (different information given in the literature) rather than TCP.

It would be interesting ... to see whether the pyrolysis product profile would be different between [NYCO's] TCP-free and [all other] TCP-containing turbine engine oils.

Jet Engine Oil

Jet Engine Oil Toxicity and Official Exposure Limits

Sittig's Handbook of Toxic and Hazardous Chemicals and Carcinogens (Pohanish 2012)

Formula: (CH₃C₆H₄O)₃PO

CAS Registry Number:

78-30-8 (o-isomer)

563-04-2 (m-isomer)

78-32-0 (p-isomer)

1330-78-5 (mixed isomers)

Hazard Symbol according to European/International Regulations:

Isomers ooo; oom; oop; omm; omp; opp: T (Toxic)

Isomers mmm; mmp; mpp; ppp: Xn (Harmful)

Description:

Tricresyl phosphates are available as the o-isomer (TOCP), the m-isomer (TMCP), and p-isomer (TCP).
The ortho-isomer is the most toxic of the three; the meta- and para-isomers are relatively inactive.

The commercial product may contain the ortho-isomer as a contaminant unless special precautions are taken during manufacture.

TOCP is the most toxic of the TCPs [TCP isomers !?] and specifically regulated by OSHA (Occupational Safety and Health Administration, USA)

OSHA PEL: 100 µg/m³ TWA.

Other countries and states specify basically all the same value of PEL = 100 µg/m³ TWA.

Lowest PEL specified overall is 1.0 µg/m³ (North Dakota).

(https://www.osha.gov/dts/chemicalsampling/data/CH_274200.html ; <https://www.cdc.gov/niosh-rtecs/td55730.html>)

PEL: permissible exposure limit. **TWA:** Time-Weighted Average

Definition: "TWA is the employee's average airborne exposure in any 8-hour work shift of a 40-hour work week which shall not be exceeded."

"The 8-hour TWA PEL is ... the highest level of exposure an employee may be exposed to without incurring the risk of adverse health effects."

The **equivalent permissible exposure limit for a mixture**, $PEL_{eq} = \sum C_i / PEL_i$

(<http://www.osha.gov>)

Jet Engine Oil

Manufacturer Specified Jet Engine Oil Content and Toxicity

SAFETY DATA SHEET (MSDS) MOBIL JET OIL II (Exxon 2016c)

Synthetic Esters and Additives

Name	CAS#	Concentration*	GHS Hazard Codes
N-PHENYL-1-NAPHTHYLAMINE	90-30-2	1%	H302, H317, H400(M factor 1), H410(M factor 1)
ALKYLATED DIPHENYL AMINES	68411-46-1	1 - < 5%	H402, H412
TRICRESYL PHOSPHATE	1330-78-5	1 - < 3%	H361(F), H400(M factor 1), H410(M factor 1)



Exxon fails to specify the ortho Cresyl (OC) concentration of the oil. Exxon only uses the CAS# for the mixed isomers, as such hiding information.

H302: Harmful if swallowed

H317: May cause allergic skin reaction

H361(F): Suspected of damaging fertility

H400: Very toxic to aquatic life, H402: Harmful to aquatic life

H410: Very toxic to aquatic life with long lasting effects, H412: Harmful to aquatic life with long lasting effects

Remark:

*According to the stated Health Hazards of Mobil Jet Oil II and the information in Michaelis 2010 (p. 67), the ortho content must be less than 0,2% in the oil (6,7% in the TCP) otherwise instead of the "harmful" declaration a "toxic" declaration would be mandatory. But with $q = 6,7\%$, $TEF = 1,47$ and hence **the TCP may still be more toxic than pure TOCP under the given hazard declaration!***

Jet Engine Oil

EASA Study 2017: AVOIL (EASA 2017b)

AVOIL – Characterisation of the toxicity of aviation turbine engine oils after pyrolysis

"From the experimental work on detecting chemicals it is concluded that the **commercial oils** included in this study do **contain TCP**, however no tri-ortho cresyl phosphate [TOCP] isomers could be detected. *Remark: The content of DOCP and MOCP is not mentioned.*

A list of **127 compounds [VOC]** was identified ...

(For **hazard profile** see Appendix 6 of EASA 2017b. See Remark 3 below.)

Analysis of the human sensitivity variability factor showed that the complete **metabolic pathway** and the contribution of inter individual variability in the metabolic enzymes **is still largely unknown** for the majority of industrial chemicals, ...

Based on the study on toxic effects of the oils after pyrolysis it was concluded that the current data indicate that **neuroactive pyrolysis products are present**, ...

... **but** that their concentration in the presence of an intact lung barrier is that low that it could **not** be appointed as **a major concern** for neuronal function."

Remarks:

- 1.) *No more TOCP. Good, but DOCP and MOCP were not in the focus. This could be misleading.*
- 2.) *What about people with deficits in their lung barrier functionality?*
- 3.) *"not ... a major concern for neuronal function" drawn too quick in view of the 127 compounds found, many with their individual hazards and possible interaction and their effect on humans.*

Jet Engine Oil

Jet Engine Oil – How Dangerous?

Cannon 2016

TCP is an organophosphates (OP). OPs are a neurotoxin. They cause:

- instantaneous interference in brain and nerve functioning,
- degeneration of the central and peripheral nervous systems,
- long-term brain cell death.

Michaelis 2010, Pohanish 2012

Symptoms on acute exposure are nausea, vomiting, diarrhea, and abdominal pain (Pohanish 2012).

Irritation of the skin and eyes, respiratory irritation, headache, vomiting, diarrhea and abdominal pain, muscle weakness, tingling sensations of the hands and feet and cramps (Michaelis 2010).

Abou-Donia 2013

It is clear that certain risks may be associated with exposure to cabin air emissions. Certain groups, including infants, the elderly, and the chronically ill, that are especially susceptible to toxic exposure to pyrolyzed engine oil and hydraulic fluid need to be protected.

GCAQE 2017

It must be noted:

Occupational exposure limits do not apply to the public, especially not the unborn, young children, sick or the elderly. Also, for those that exist, they apply to single chemicals only in their original state and not to either complex mixtures of chemicals or thermally degraded substances.

House of Lords 2007

Question [HL1761]:

What exposure standards currently apply to any synergistic effects of simultaneous exposure to numerous chemicals ... in a reduced pressure environment?

Answer: None.

Interview with Prof. Abou-Donia (van Beveren 2011)

Every breath is a dose and accumulates in the body.

Cabin Comfort and Cabin Air Quality – Health and Flight Safety Implications – Certification Requirements

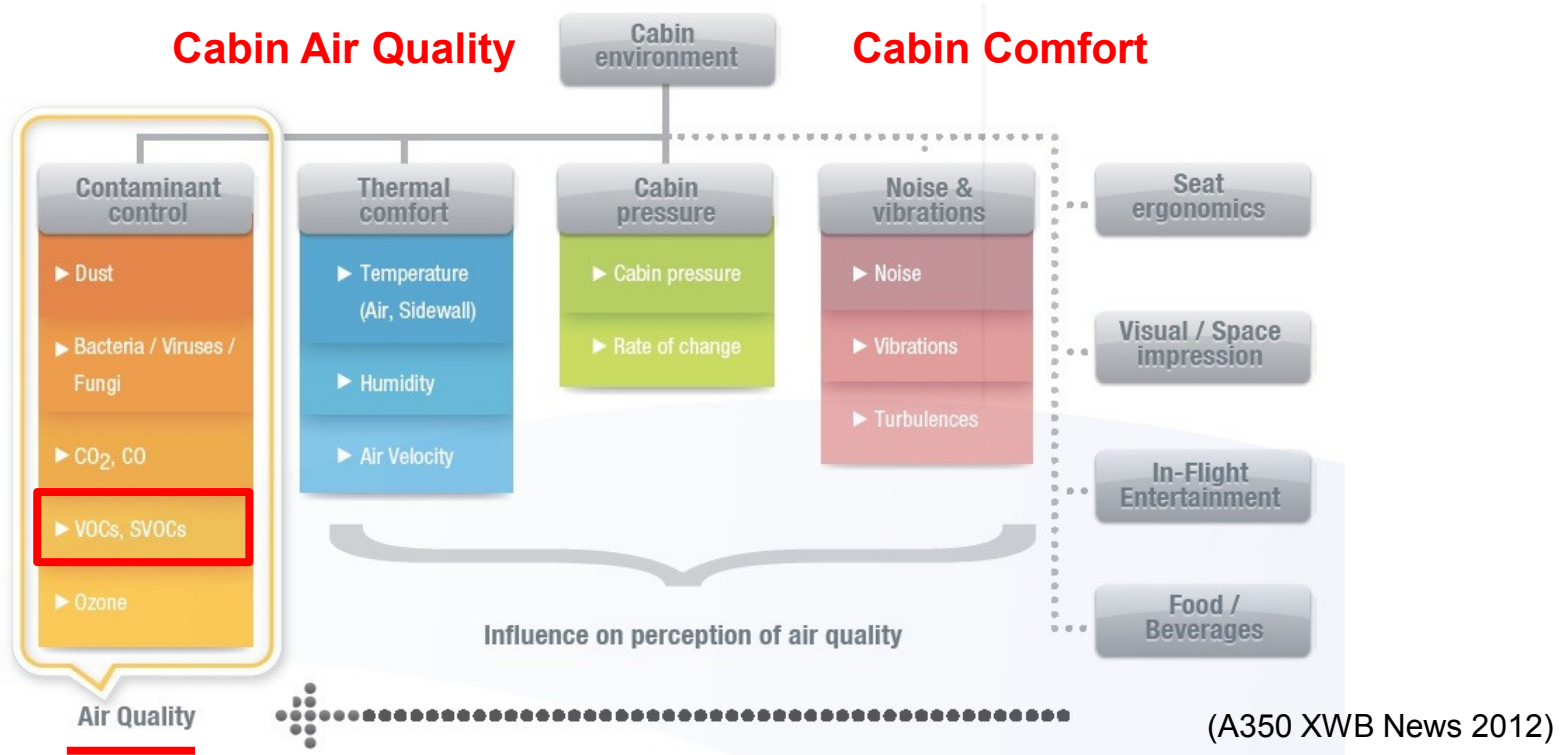

VOC: Volatile Organic Compounds are (organic chemicals – i.e. including carbon) contained in many products and can be released from these products into the surrounding air. **Regulations limit VOCs.**

SVOC: Semi-Volatile Organic Compound

(Eurofins 2017)

Cabin Comfort and Cabin Air Quality – Health and Flight Safety Implications – Certification Requirements

<u>Potential sources ... of air contamination</u>	Potential impact
Engine start during push back	<u>Exhaust gases</u> (e.g., CO, CO ₂ , NO _x , fuel, particles)
Bleed air switch off during engine start	Short time increase of CO ₂
Cabin cleaning in general	VOC, e.g. alcohols, flavors (terpenes), aldehydes
<u>Interior cleaning</u>	Residual of tetrachloroethene
No ozone converters installed	Ozone, particularly in cruise
<u>De-icing fluids</u>	1,2-Propanediol (major constituent) and various additives (e.g., dyes, thickener, antioxidants)
Aircraft traffic at the airport	Exhaust gases (e.g., CO, CO ₂ , NO _x , fuel, particles)
Car traffic at the airport	Exhaust gases (e.g., CO, CO ₂ , NO _x , gasoline, particles)
Passengers	Emission of CO ₂ , various VOCs, offensive smell
Restrooms	Smell, VOC from cleaning products
<u>Furnishings</u>	VOC/SVOC, particulate organic matter (POM), flame retardants e.g. organophosphates
Maintenance	Various VOCs, lubricants
Lubricants	Oil base stock, organophosphates, POM
<u>Hydraulic fluids</u>	e.g. Tributyl phosphate (TBP), triphenyl phosphate (TPP)
Engine oils	Tricresyl phosphate (<u>TCP</u>), trixylyl phosphate (TXP), Amines
In case of thermal degradation	<u>VOCs</u> , organic acids, aldehydes, CO, CO ₂ , potential unknown products

(EASA 2017a)

only
considered
here is:

Cabin Comfort and Cabin Air Quality – Health and Flight Safety Implications – Certification Requirements

Health Effects from Indoor Air Pollutants

may be experienced soon after exposure or, possibly, years later:

- **Long-term health effects:**
 - to passengers
 - to crew => **occupational health (OH)** **=> CS 25.831**
usually related to
Time-Weighted Average (TWA)
Permissible Exposure Limits (PEL)
- **Immediate health effects:**
 - to passengers
 - to cabin crew
 - to cockpit crew => **flight safety implications** can lead to:
injury or death of
 - passenger
 - crew **=> CS 25.1309**

(Eurofins 2017, EASA CS-25)

Cabin Comfort and Cabin Air Quality – Health and Flight Safety Implications – Certification Requirements

Long Term Health Effects – Occupational Health ?

EASA CS-25: CS 25.831 Ventilation

- (a) Each passenger and crew compartment must be ventilated ... to **enable crewmembers to perform their duties without undue discomfort or fatigue.**
- (b) **Crew and passenger compartment air must be free from harmful or hazardous concentrations of gases or vapours.** In meeting this requirement, the following apply: (1) Carbon monoxide concentrations in excess of one part in 20000 parts of air [50 ppm] are considered hazardous. For test purposes, any acceptable carbon monoxide detection method may be used. (2) Carbon dioxide concentration ...

"EASA is of the opinion ... only applicable for ... CO and CO2"

*Remark: EASA's interpretation of certification rules: The **cabin is allowed to be contaminated with other substances!***

"The **BFU** is of the opinion that 'harmful concentration' should be interpreted ... to mean that **health impairments** (including long-term) through contaminated cabin air should be **eliminated.**"

"The **BFU** is of the opinion that a product [aircraft] which has received a type certificate by EASA should be designed in a way that **neither crew nor passengers** are harmed or **become chronically ill.**"

(BFU 2014)

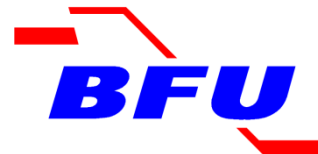

Bundesstelle für Flugunfalluntersuchung
German Federal Bureau of
Aircraft Accident Investigation

Cabin Comfort and Cabin Air Quality – Health and Flight Safety Implications – Certification Requirements

Immediate Health Effects – Flight Safety Implications?

EASA CS-25: CS-25.1309(b)

The aeroplane systems and associated components, considered separately and in relation to other systems, must be designed so that

- (1) Any catastrophic failure condition
 - (i) is extremely improbable; and
 - (ii) does not result from a single failure; and
- (2) Any hazardous failure condition is extremely remote; and
- (3) Any major failure condition is remote.

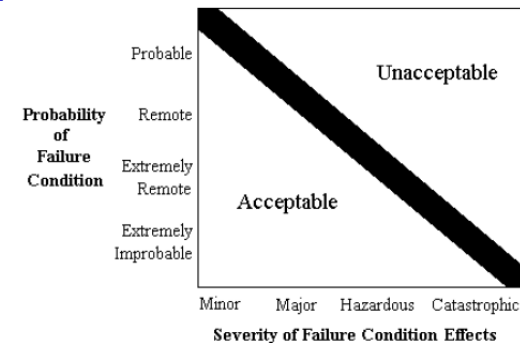

EASA CS-25: CS-25.1309 / AMC: System Design and Analysis

The following definitions apply to the system design and analysis requirements of CS 25.1309

Error: An omission or incorrect action by a crewmember or maintenance personnel, or a mistake in requirements, design, or implementation.

Failure: An occurrence, which affects the operation of a component, part, or element such that it can no longer function as intended, (this includes both loss of function and malfunction). Note: Errors may cause Failures, but are not considered to be Failures.

It was assumed, arbitrarily, that there are about one hundred potential Failure Conditions in an aeroplane [one in each of an assumed number of 100 systems], which could be Catastrophic.

The CS-25 airworthiness standards are based on ... the fail-safe design concept ... The fail-safe design concept uses the following design principles:

- (i) Designed Integrity and Quality, including Life Limits, to ensure intended function and prevent failures.
- (v) Failure Warning or Indication to provide detection.
- (xi) Error-Tolerance that considers adverse effects of foreseeable errors during the aeroplane's design, test, manufacture, operation, and maintenance.

Cabin Comfort and Cabin Air Quality – Health and Flight Safety Implications – Certification Requirements

Flight Safety Implications?

EASA CS-25: CS-25.1309(b) / AMC

"In regard to the demonstration of compliance in accordance with CS-25.1309, EASA classifies the **impairment** of the capability to act (without incapacitation) as "**Major**" [$< 10^{-5}$]. This means, however, that **these events**, with a certain frequency of occurrence, **are accepted**. The **social acceptance** of this value **cannot be assessed ...**"

(BFU 2014)

Remarks:

1. EASA's classification is wrong. "impairment" is "Hazardous" ($< 10^{-7}$) and demands less frequent occurrence by a factor of 100.
2. CS-25.1309 is meant for failure cases of statistical nature and not as an excuse for known and deliberate negligence in design! (see next page for details)

Effect on <u>Aeroplane</u>	No effect on operational capabilities or safety	Slight reduction in functional capabilities or safety margins	Significant reduction in functional capabilities or safety margins	Large reduction in functional capabilities or safety margins	Normally with <u>hull loss</u>
Effect on Occupants excluding <u>Flight Crew</u>	Inconvenience	Physical discomfort	Physical distress, possibly including injuries	Serious or fatal injury to a small number of passengers or cabin crew	<u>Multiple fatalities</u>
Effect on <u>Flight Crew</u>	No effect on flight crew	Slight increase in workload	Physical discomfort or a significant <u>increase in workload</u>	Physical distress or excessive workload <u>impairs ability to perform tasks</u>	<u>Fatalities or incapacitation</u>
Allowable Qualitative Probability	No Probability Requirement	<---Probable--->	<---Remote--->	Extremely <-----> Remote	Extremely Improbable
Allowable Quantitative Probability: <u>Average Probability per Flight Hour on the Order of:</u>	No Probability Requirement	<-----> < 10^{-3} Note 1	<-----> < 10^{-5}	<-----> < 10^{-7}	< 10^{-9}
Classification of Failure Conditions	No Safety Effect	<---Minor--->	<---Major--->	<---Hazardous--->	<u>Catastrophic</u>
Note 1: A numerical probability range is provided here as a reference. The applicant is not required to perform a quantitative analysis, nor substantiate by such an analysis, that this numerical criteria has been met for Minor Failure Conditions. Current transport category aeroplane products are regarded as meeting this standard simply by using current commonly-accepted industry practice.					

Cabin Comfort and Cabin Air Quality – Health and Flight Safety Implications – Certification Requirements

Interpretation of AMC 25.1309 with respect to Bleed Air from Jet Engines

EASA CS-25: AMC 25.1309: System Design and Analysis

The aeroplane systems and associated components, must be designed so that

- (1) Any catastrophic failure condition
- (2) (ii) does not result from a single failure

Attention: A single seal failure has the potential to cause a catastrophic failure due to pilot incapacitation. This is in contradiction to CS-25.

EASA CS-25: AMC 25.1309: System Design and Analysis

The CS-25 airworthiness standards are based on ... the fail-safe design concept ...

The failure probability of a system is calculated based on the Mean Time Between Failure (MTBF) of its components. The components are normally functional, but may fail randomly. 100% reliability of components does not exist. This is much in contrast to the situation of bleed air taken from the engine which is systematically contaminated (to some extent) with engine oil. This is not a failure (for which a probability could be calculated), but a design error (violating existing SAE design conventions).

EASA CS-25: AMC 25.1309: System Design and Analysis

The fail-safe design concept uses the following design principles:

- (i) Designed Integrity and Quality
- (v) Failure Warning or Indication to provide detection.
- (xi) Error-Tolerance that considers adverse effects of foreseeable errors during the aeroplane's design, test, manufacture, operation, and maintenance.

But with bleed air from jet engines:

- (i) Design integrity is not given!*
- (v) Failure Warning in case of cabin air contamination is not provided!*

Furthermore:

- (xi) Known deficiencies are not allowed. The system has to be error-tolerant to yet UNKNOWN design errors that have to be envisaged because it is a known fact in life that errors do occur (and as such they are foreseeable). The system's error-tolerance is compromised, if it has to cope with already known design errors that are not rectified out of negligence relying on the systems error-tolerance.*

Cabin Comfort and Cabin Air Quality – Health and Flight Safety Implications – Certification Requirements

Flight Safety Implications Due to Cabin Air Contamination?

There have been **several** (much debated) **critical flight instances**, but so far (luckily) **no death** (due to flight safety implicatons) and **no hull loss**.

Compare e.g. with the issue "**Degraded Manual Flying Skills**" (Flight International 2017)

Fatal in-flight loss of control accidents

Year	Operator	Type	Location	Fatalities
2016	Egyptair	Airbus A320	Mediterranean Sea off Egypt	66
	Flydubai	Boeing 737-800	Rostov-on-Don, Russia	62
2014	AirAsia Indonesia	Airbus A320	Java Sea, Indonesia	162
	Swiftair	Boeing MD-83	Mali	116
2013	Tatarstan Air	Boeing 737-500	Kazan, Russia	50
	Asiana Airlines	Boeing 777	San Francisco, USA	2
2010	Afriqiyah Airways	Airbus A330-200	Tripoli, Libya	103
	Ethiopian Airlines	Boeing 737-800	Near Beirut, Lebanon	90
	Yemenia	Airbus A310-200	Comoros Islands	152
2009	Air France	Airbus A330-300	South Atlantic	228
	Caspian Airlines	Tupolev Tu-154	Iran	168
	Colgan Air	Bombardier Q400	Buffalo, New York, USA	49
2008	Aeroflot Nord	Boeing 737-500	Perm, Russia	88
2007	Adam Air	Boeing 737-400	Java Sea, Indonesia	102
2006	Armavia	Airbus A320-200	Sochi, Russia	113
2005	West Caribbean	Boeing MD-82	Venezuela	160
2004	Flash Airlines	Boeing 737-300	Sharm el-Sheikh, Egypt	148
2000	Gulf Air	Airbus A320-200	Bahrain	143
	Crossair	Saab 340	Near Zurich, Switzerland	10
Total				2,012

Source: FlightGlobal

From 2000 to 2017:

- 19 fatal accidents
- 2012 fatalities

Remark:

There are certainly several issues in aviation of more pressing nature than "cabin air quality / contamination", however, the suffering of individuals (potentially / probably) due to cabin air contamination can not be ignored (may it just be for ethical reasons), because the underlying deficits in aircraft system design are a fact (see below) and need to be solved.

Air Conditioning Technology

Air Conditioning Basics

Temperature Control, Pressure Control, Ventilation

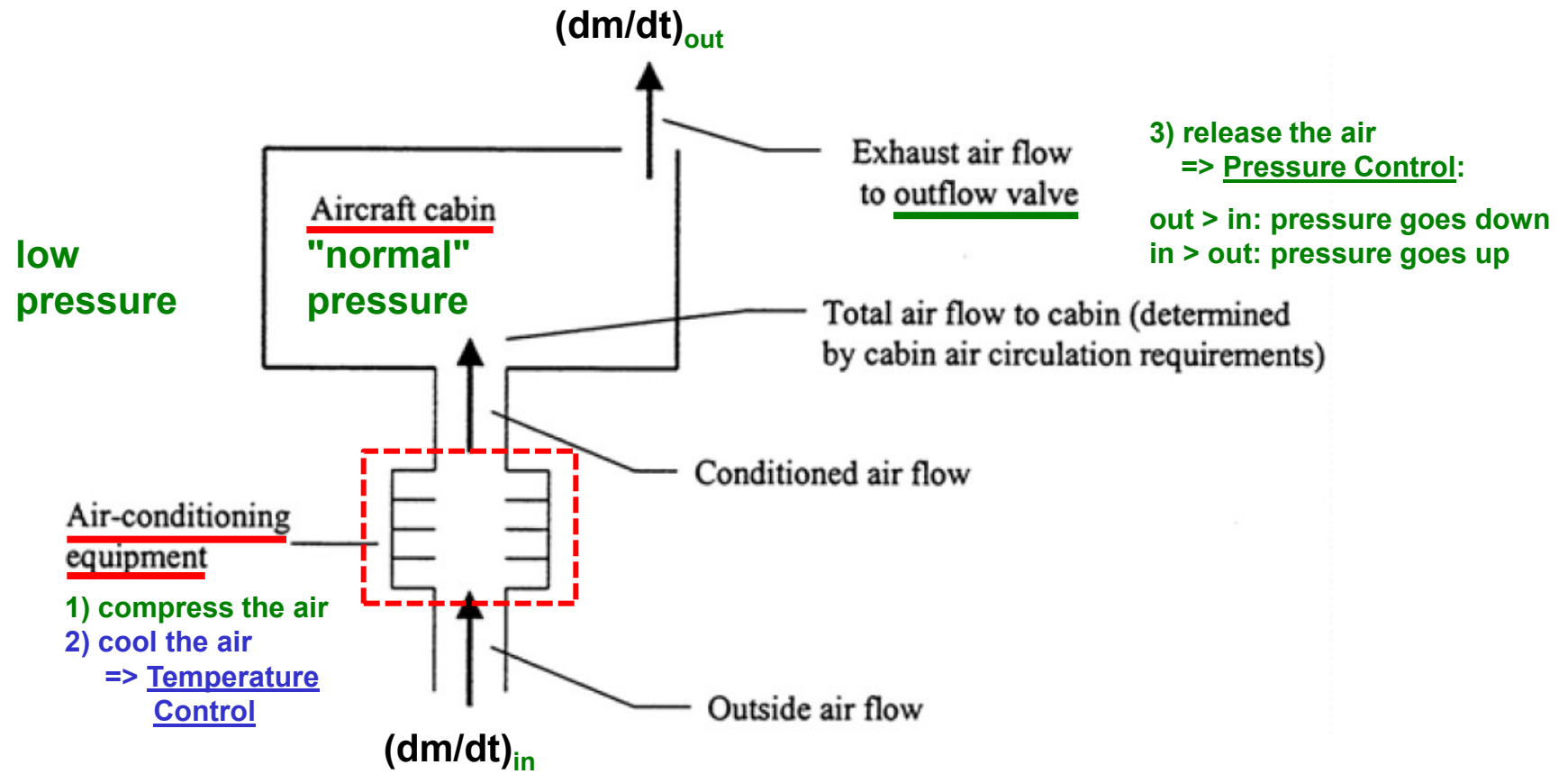

Adapted from (NRC 2002)

Air Conditioning Technology

Air Conditioning with Recirculation

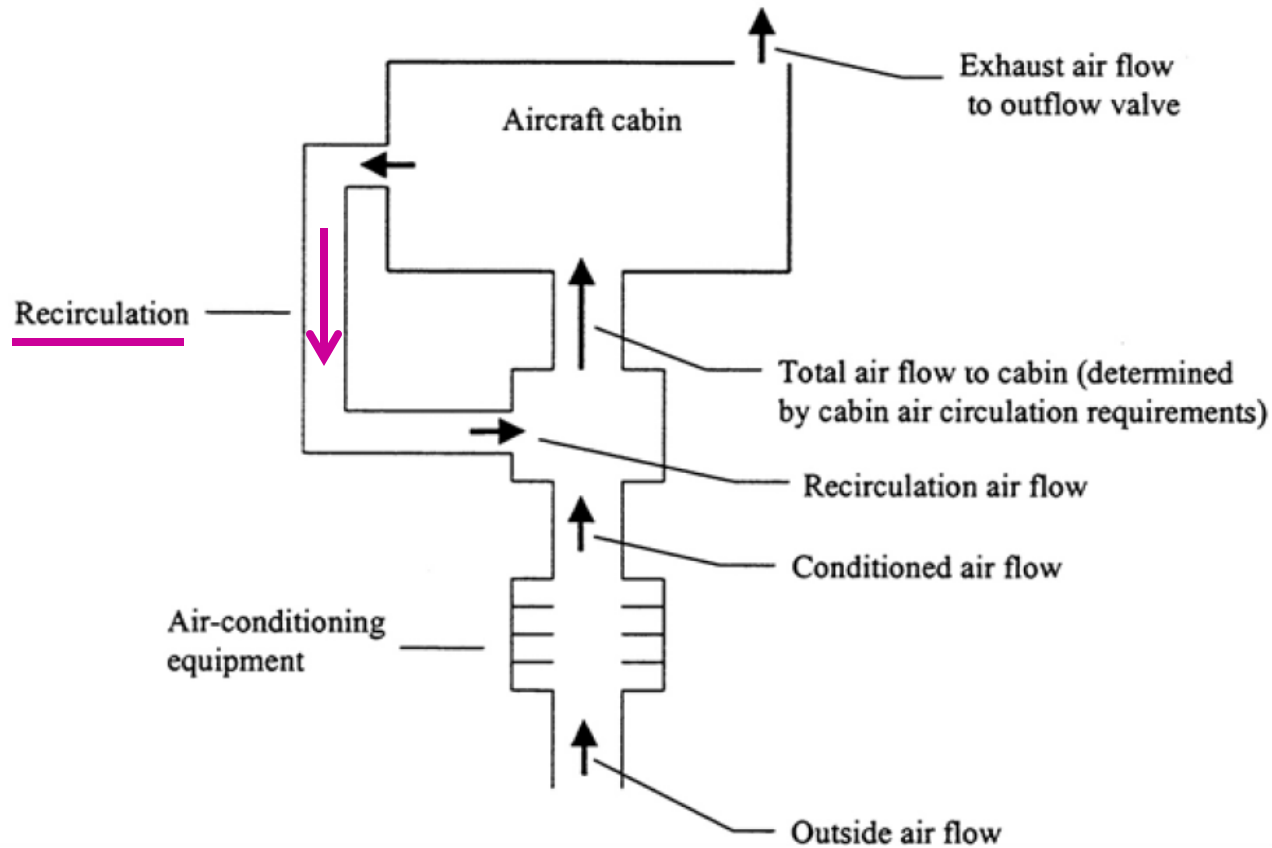

Adapted from (NRC 2002)

Air Conditioning Technology

 FLIGHT CREW OPERATING MANUAL	PNEUMATIC DESCRIPTION	1.36.10	P 3
		REV 05	SEQ 001

"Bleed Air" Generation and Treatment

compress and cool the air

"Bleed Air"

is "precious air" taken off the engine compressor – air which was initially intended to be used for the engine cycle

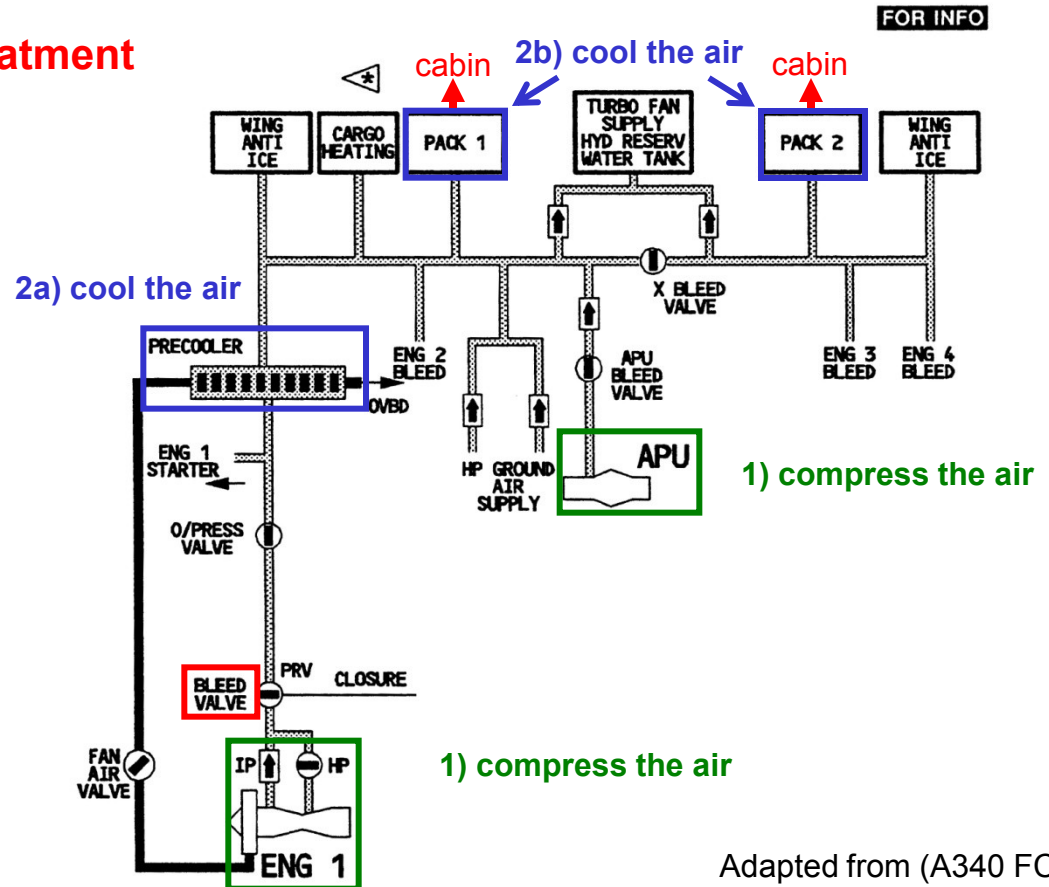

Adapted from (A340 FCOM)

Air Conditioning Technology

A320

Temperature Control

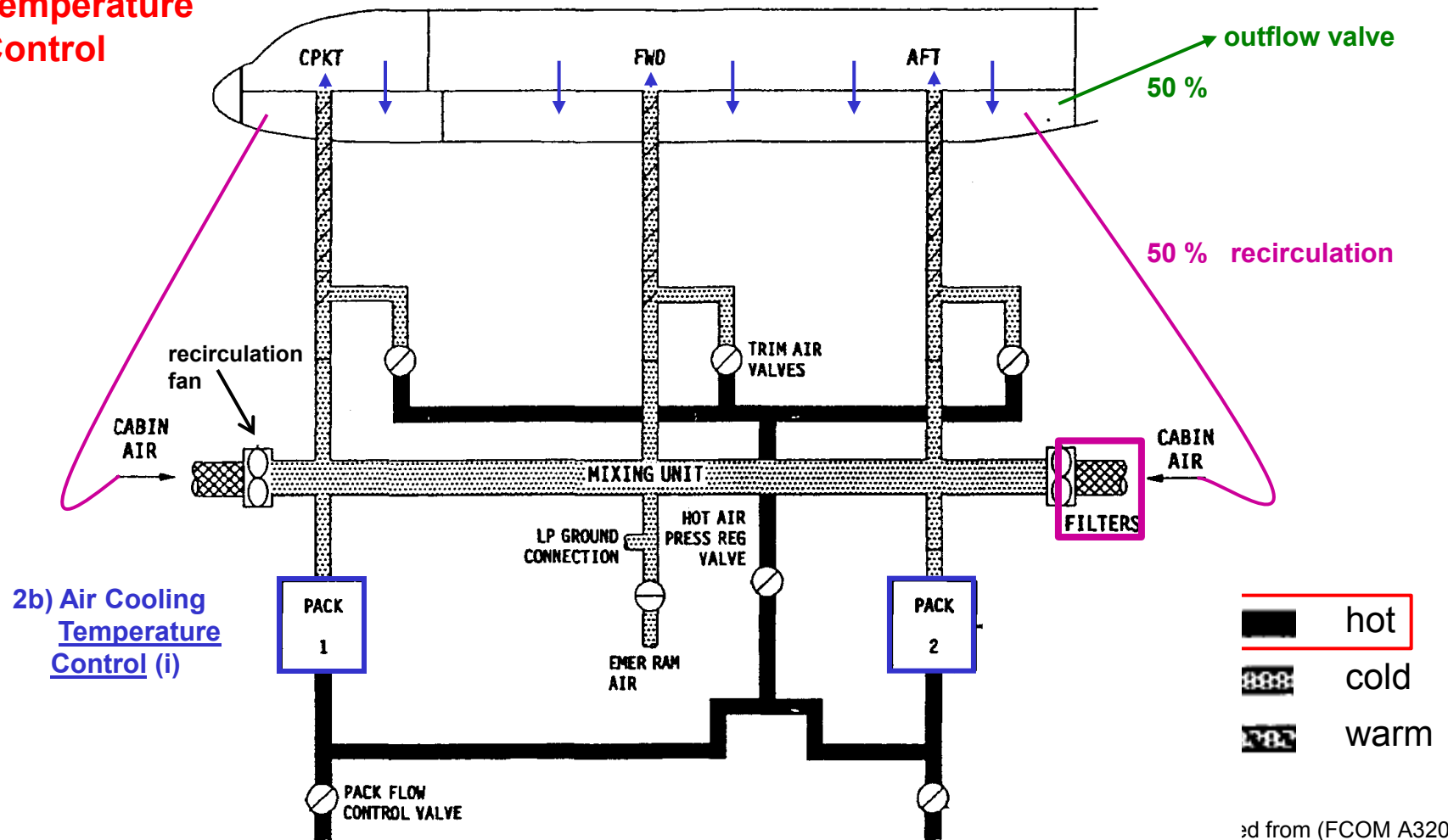

Air Conditioning Technology

Cabin Air Distribution

A320

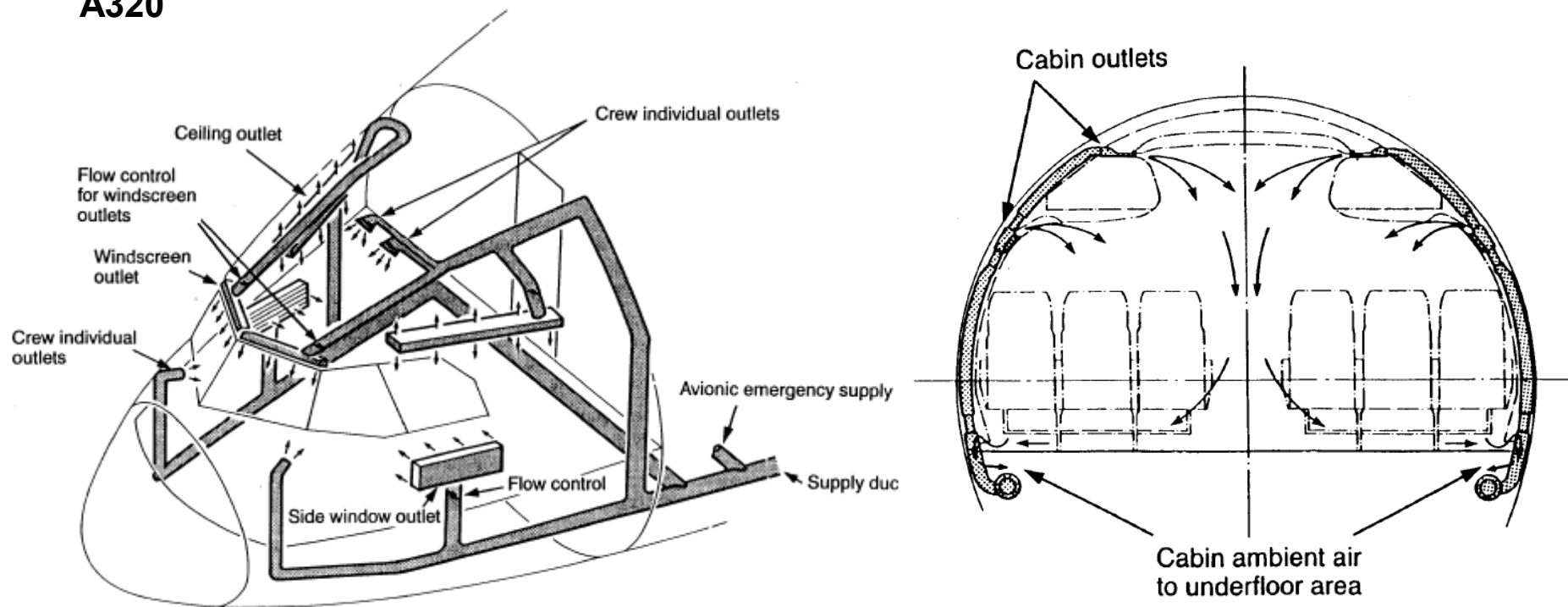

(A320 GENFAM)

Air Conditioning Technology



737-600/700/800/900 AIRCRAFT MAINTENANCE MANUAL

Major Component Location

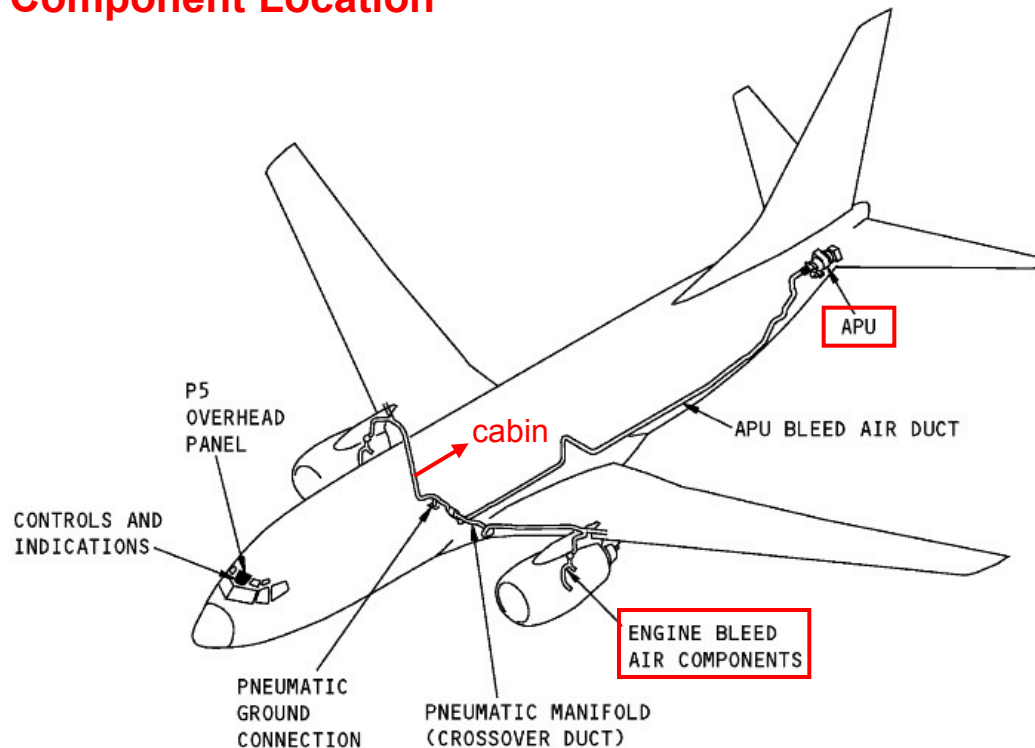

PNEUMATIC - COMPONENT LOCATIONS

(B737 AMM)

Air Conditioning Technology

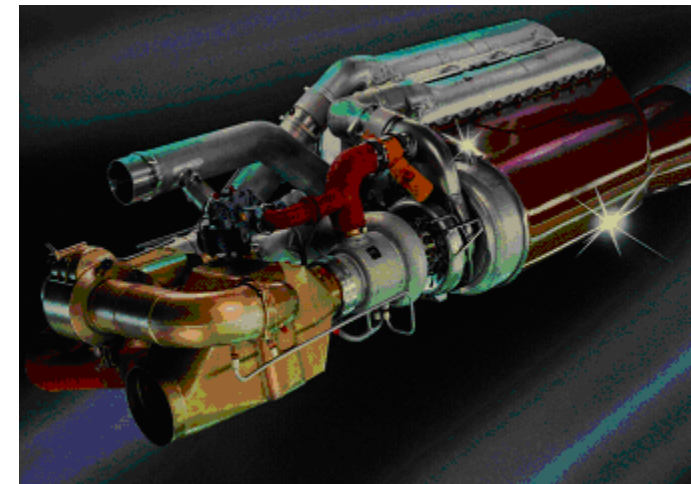
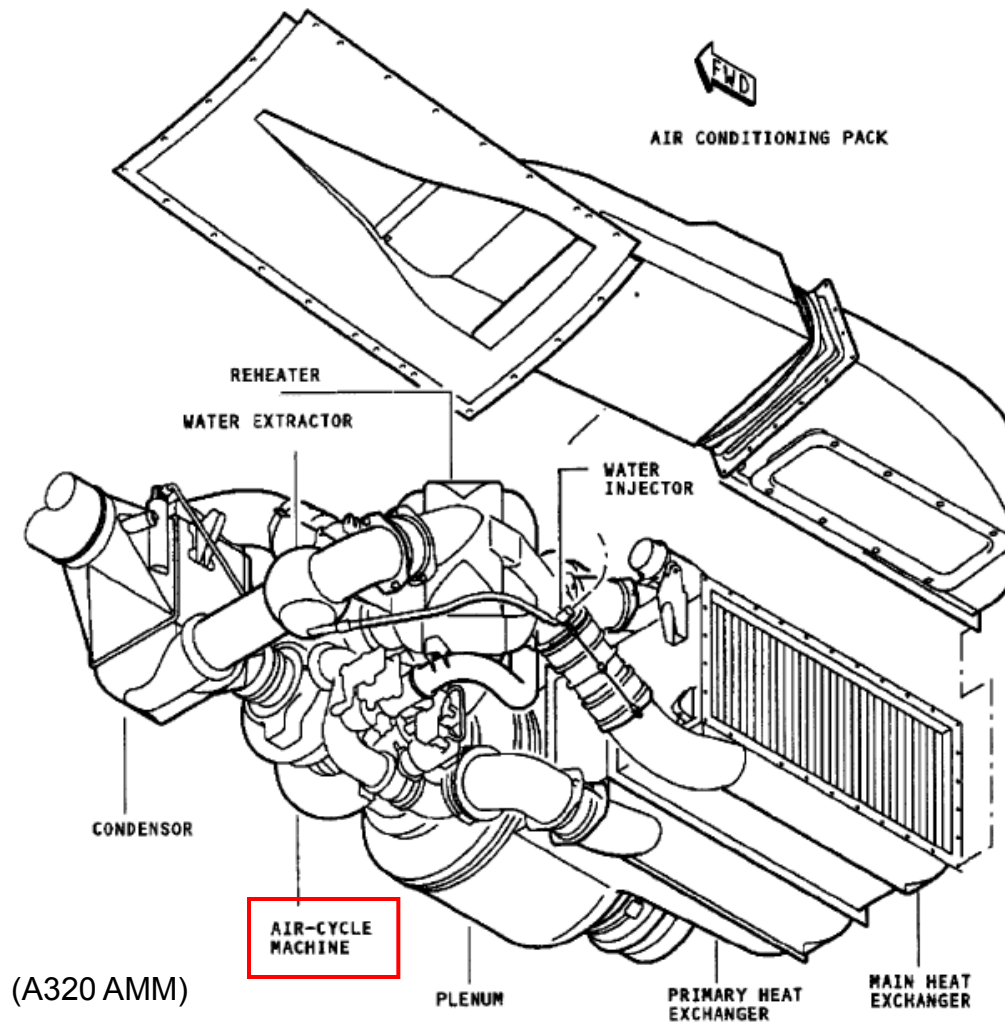

Liebherr Aerospace

Air Conditioning Pack (1/2)

A320

Air Conditioning Technology

Air Conditioning Pack (2/2)

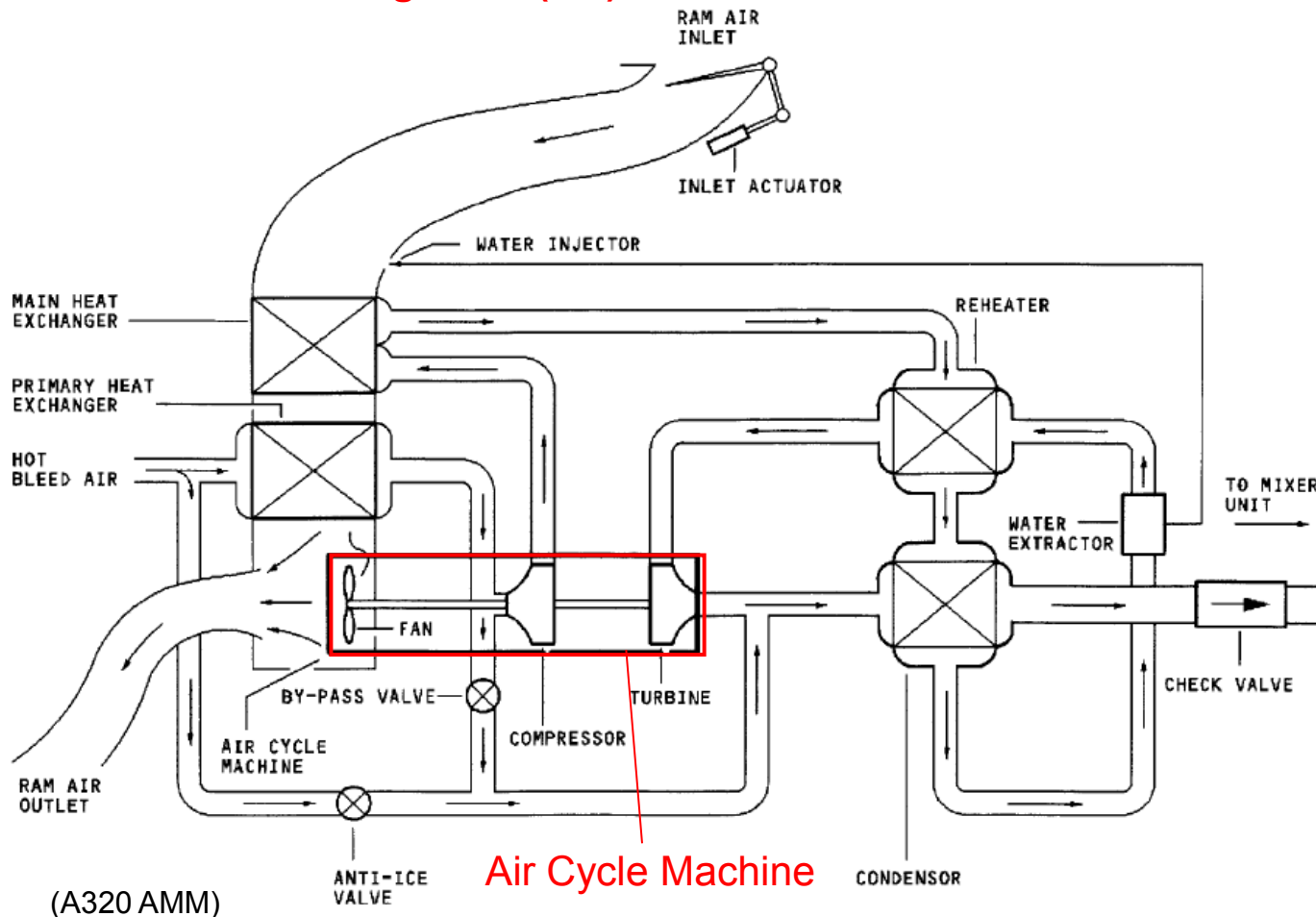

- An **Air Cycle Machine** (ACM) is a high energy rotor device.
- An ACM may need some form of lubrication (=> oil)
- Lubrication needs will be much smaller than in aircraft engines or the APU.
- Use of air bearings is possible.

Air Conditioning Technology

SAE about the Design of the Air Conditioning Pack



SAE ARP 85E: Air Conditioning Systems for Subsonic Airplanes

5.2.2.d.: Bearings:

Air cycle machines typically use precision angular contact ball bearings or **air bearings**.

In either case, **the bearing system** should be self-contained, **requiring no external oil supply or external pressurizing air source**.

Jet Engine

Engine Overview

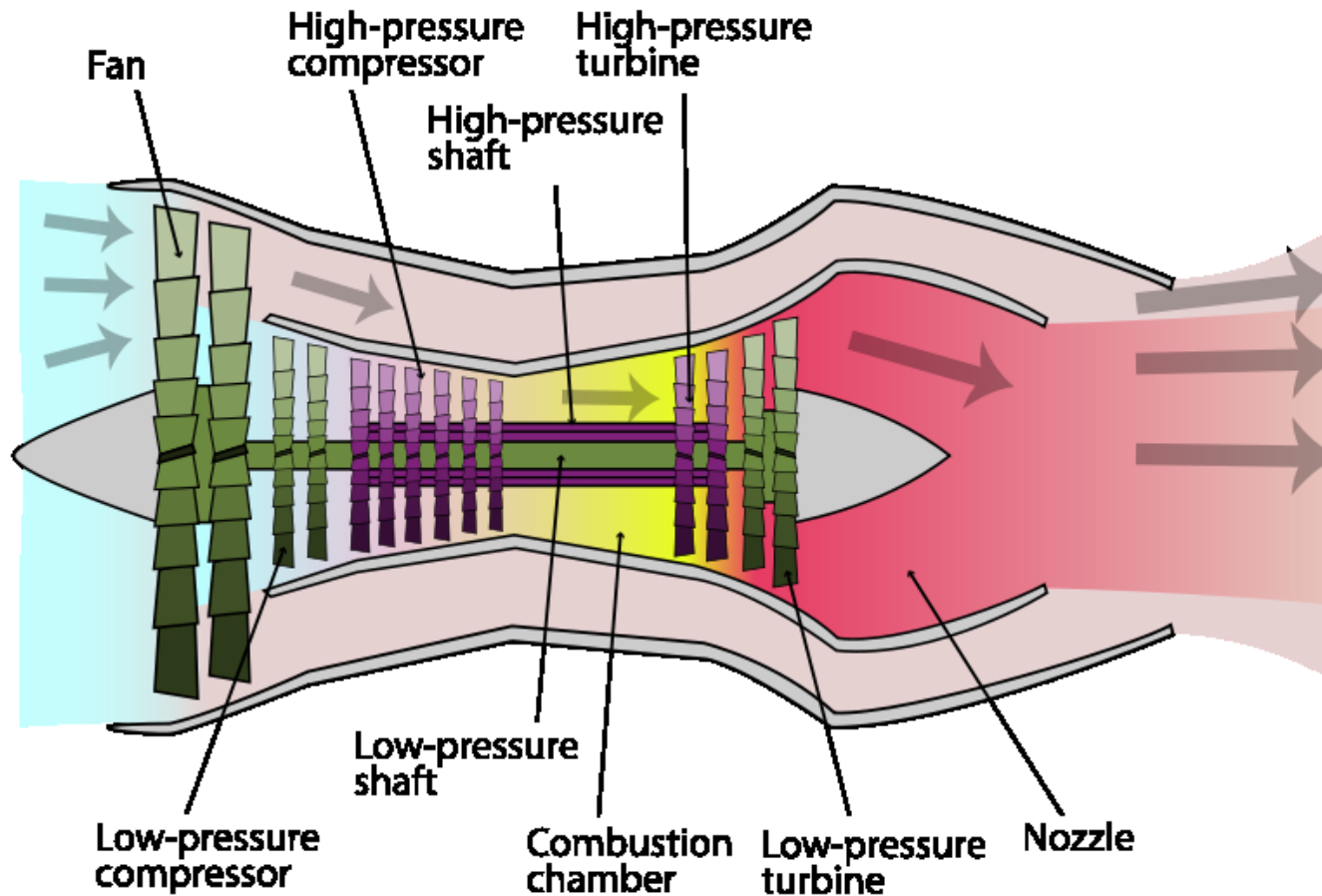

(Wikipedia 2017a)

Jet Engine

Engine Overview

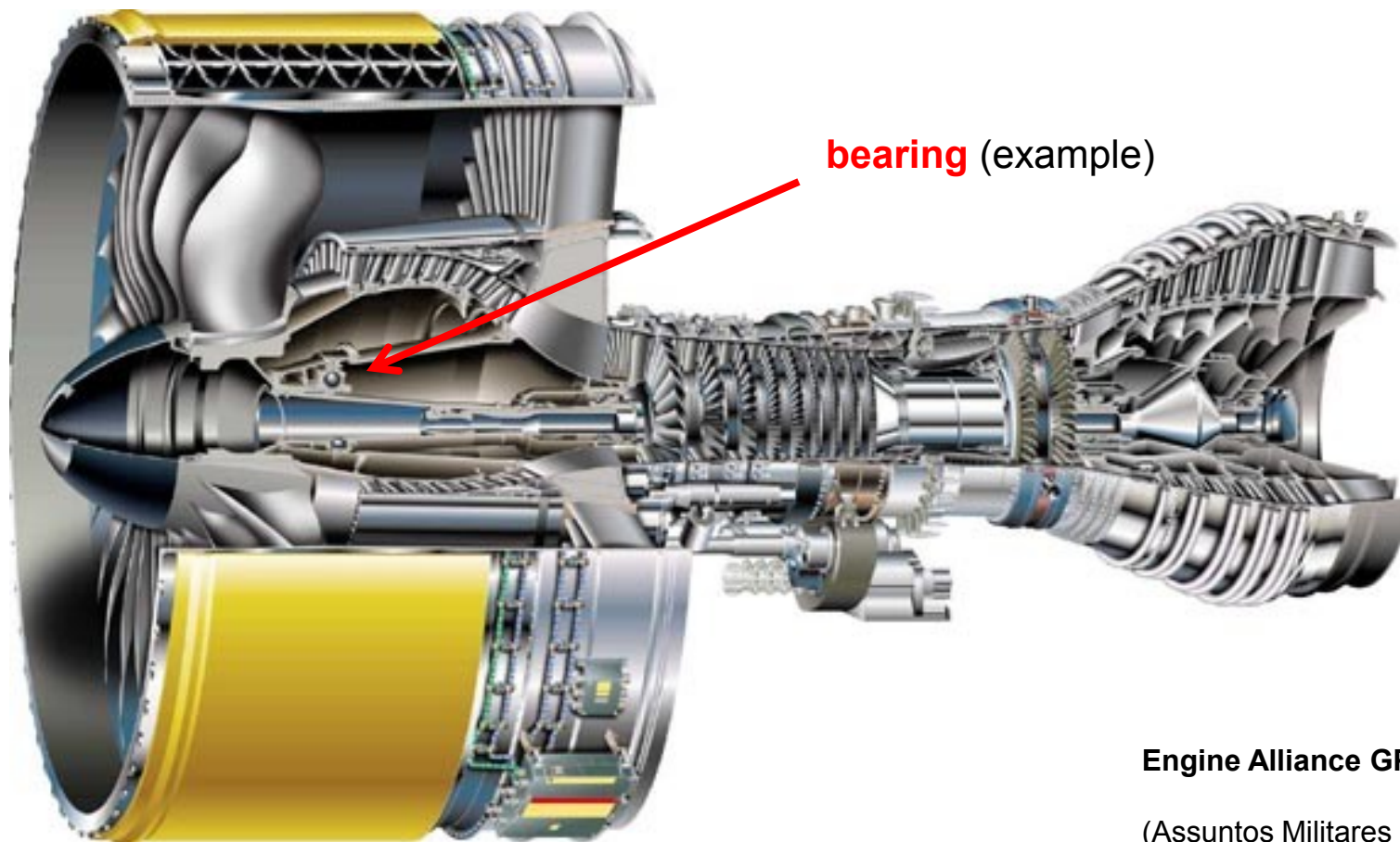

Engine Alliance GP7000

(Assuntos Militares 2013)

Jet Engine

Jet Engine Bearing



(Exxon 2016b)

Engine Air and Oil System

Quotes from: Exxon Mobile (2016a):
“**Jet Engine Oil System – Overview**”
with remarks:

- "The scavenged oil flow is slightly lower than the supply flow due to normal oil consumption through the deoiler, oil seals, and oil leaks." (*Remark: Oil escapes also from the seals*)
- "Therefore, a large amount of air is carried by the scavenge oil and must be removed through a de-aerator when entering the tank." (*Remark: Seals do not seal but allow large amounts of air to enter the seals. If pressure in the compressor is low compared to pressure in the oil system i.e. low Δp , oil can escape from the seals.*)

(Exxon 2016a)

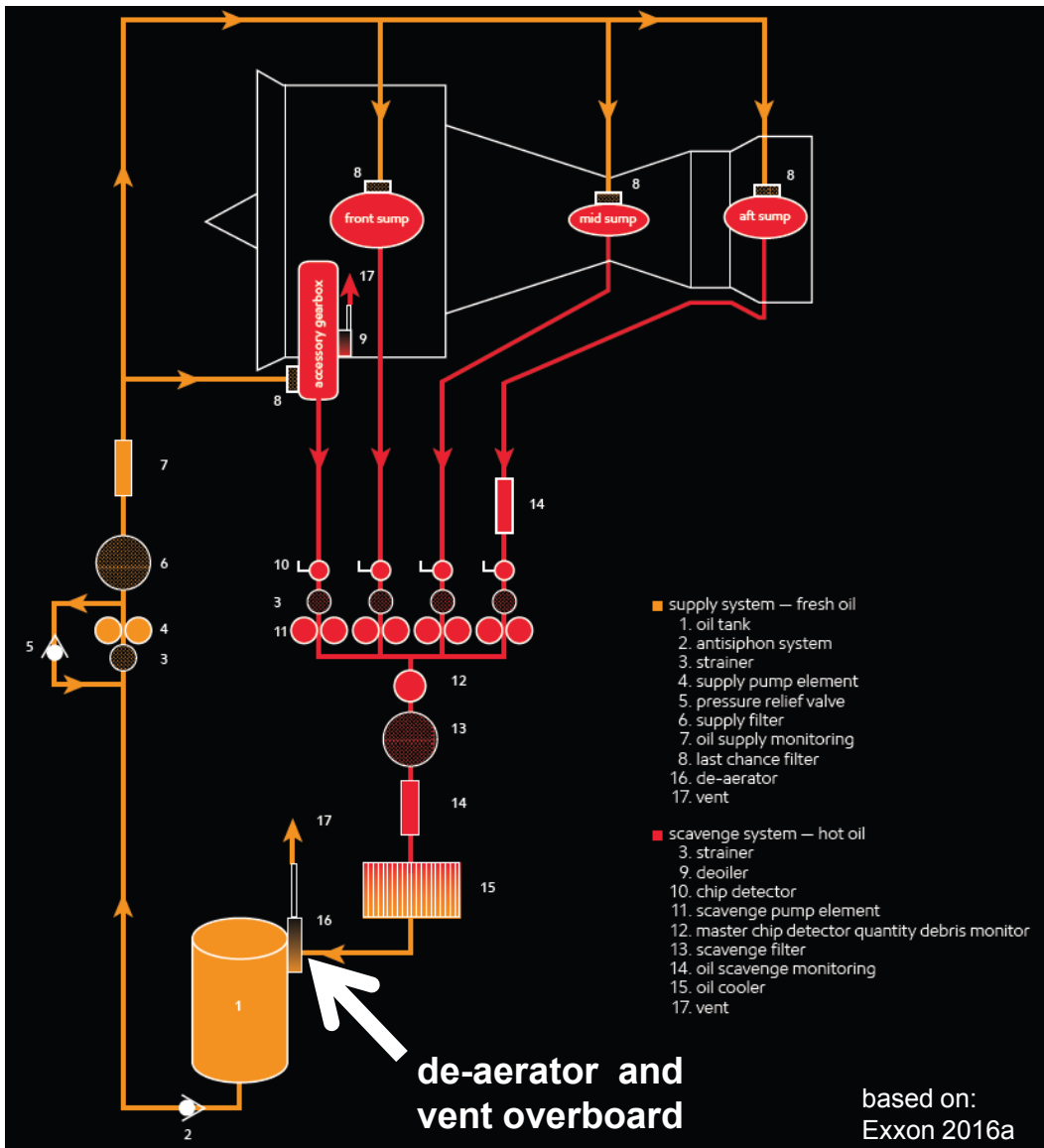

Jet Engine

Engine Air and Oil System

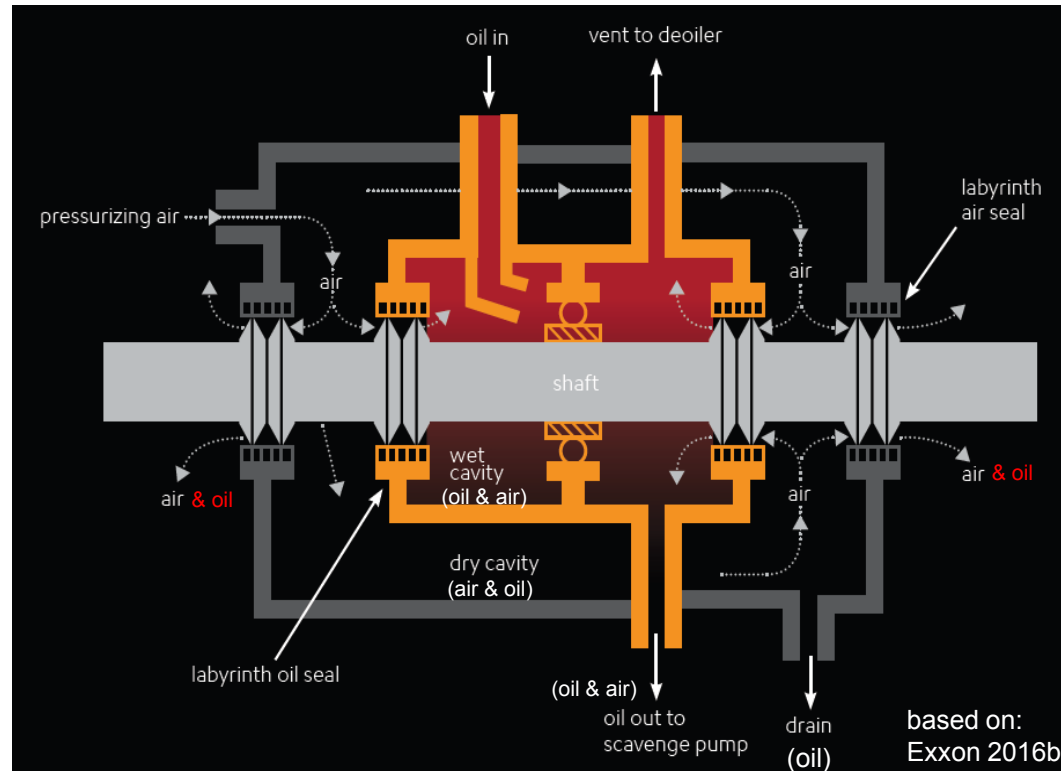

Quotes from: Exxon Mobile (2016b):

“Jet Engine Oil System – Bearing Sump Lubrication”

with remarks:

"Oil sumps are a part of the oil circuit, where oil must remain. **Leakage** outside the oil system **could pollute the air bleeds**"

"The pressure inside the oil sump must always be lower than the pressure outside the sump."

"Pressurized **air** is ... injected between two labyrinth seals ... It then **flows across the oil seals**, preventing oil seepage past the oil seals."

"Air mixes with part of the oil ... making an **oil mist** ... the vent air, ... has to be discharged **overboard** [after going] **through an air/oil separator** [the de-aerator]."

"The **vent tube** must remain **wide open to avoid leaks** due to low Δp through the oil seals." (Remark: Accordingly, prerequisite for leakage is not necessarily a negative Δp – instead, a low Δp is sufficient for leakage. It can happen e.g. with partial blockage of the vent tube.)

"The double wall around the sump ... applies to sumps ... in the hot areas." "Some designs do not use double walls, particularly when carbon seals are used."

"In many applications, oil that crosses the oil seal is collected and routed by a tube to an aircraft drain collector that is inspected from time to time and is used as a seal monitoring tool."

Remarks:

- 1.) When a **double wall design** is used, 'air with some oil' is in the so called 'dry cavity' (some of this oil is drained). **Air with a low oil content is leaving the 'dry cavity' into the compressor** (see picture).
- 2.) When double walls are used, oil leaks from the inner seal to the 'dry cavity'.
Therefore: When only a **single wall design** is used, **air and oil leak directly into the compressor**.
- 3.) **Conclusion: In both cases: Jet engine seals leak oil by design.** Read more on this topic: **Michaelis 2016a** and **Michaelis 2016b**

Jet Engine

Types of Jet Engine Seals

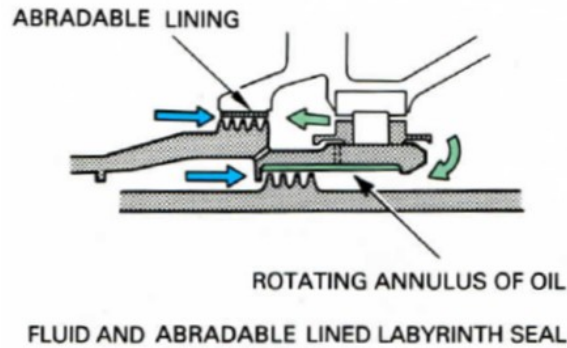
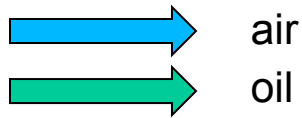

FLUID AND ABRADABLE LINED LABYRINTH SEAL

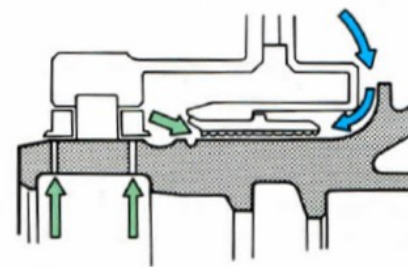
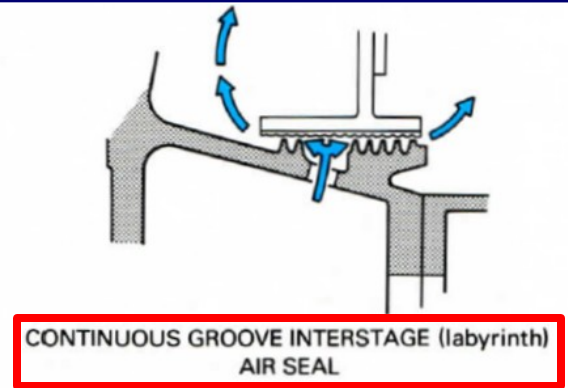

THREAD TYPE (labyrinth) OIL SEAL

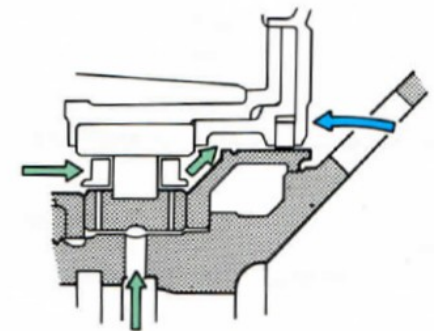

RING TYPE OIL SEAL

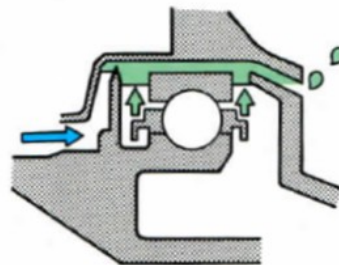

INTERSHAFT HYDRAULIC SEAL

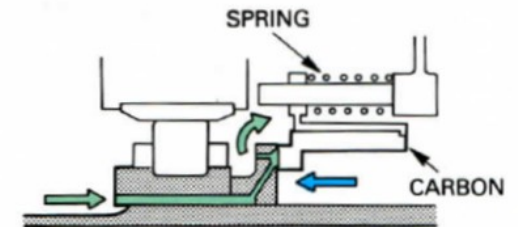

CARBON SEAL

(Rolls Royce 2015)

Jet Engine

Types of Jet Engine Seals

Brush Seal

e.g. on

PW1000G

geared turbo fan

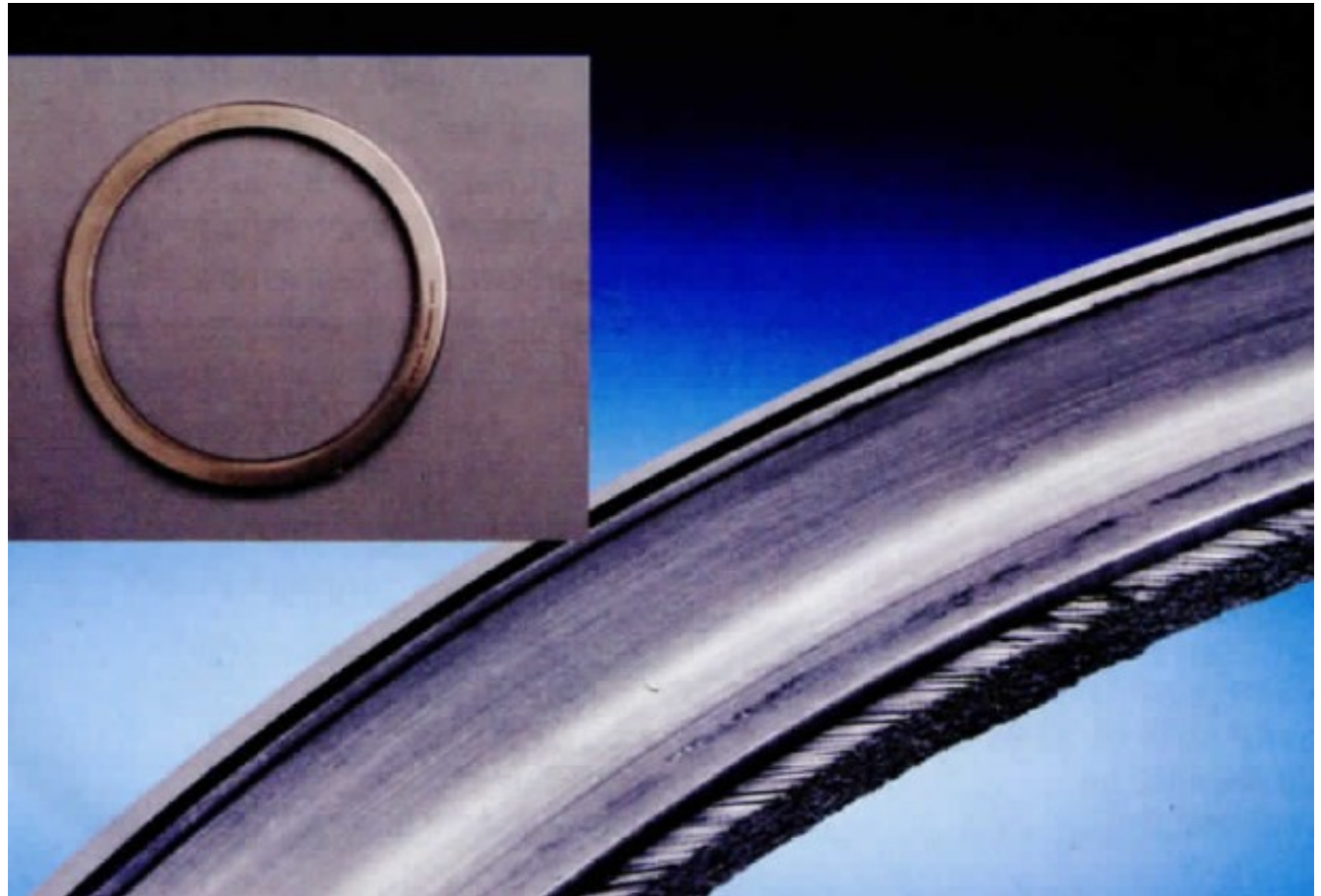

(DGLR 2014)

Auxiliary Power Unit (APU)

Overview

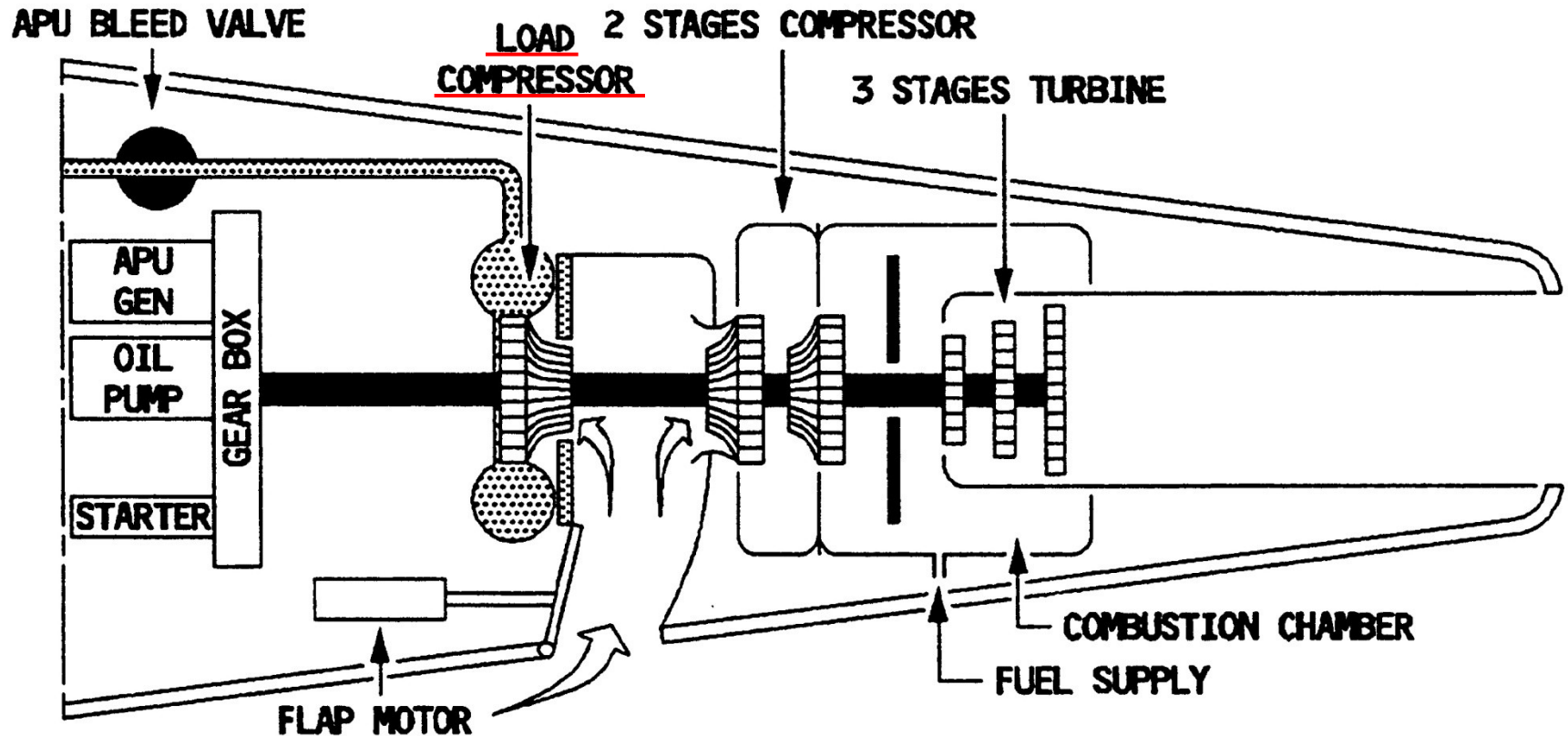

APU Description (A340 FCOM)

Auxiliary Power Unit (APU)

Bearings and Load Compressor

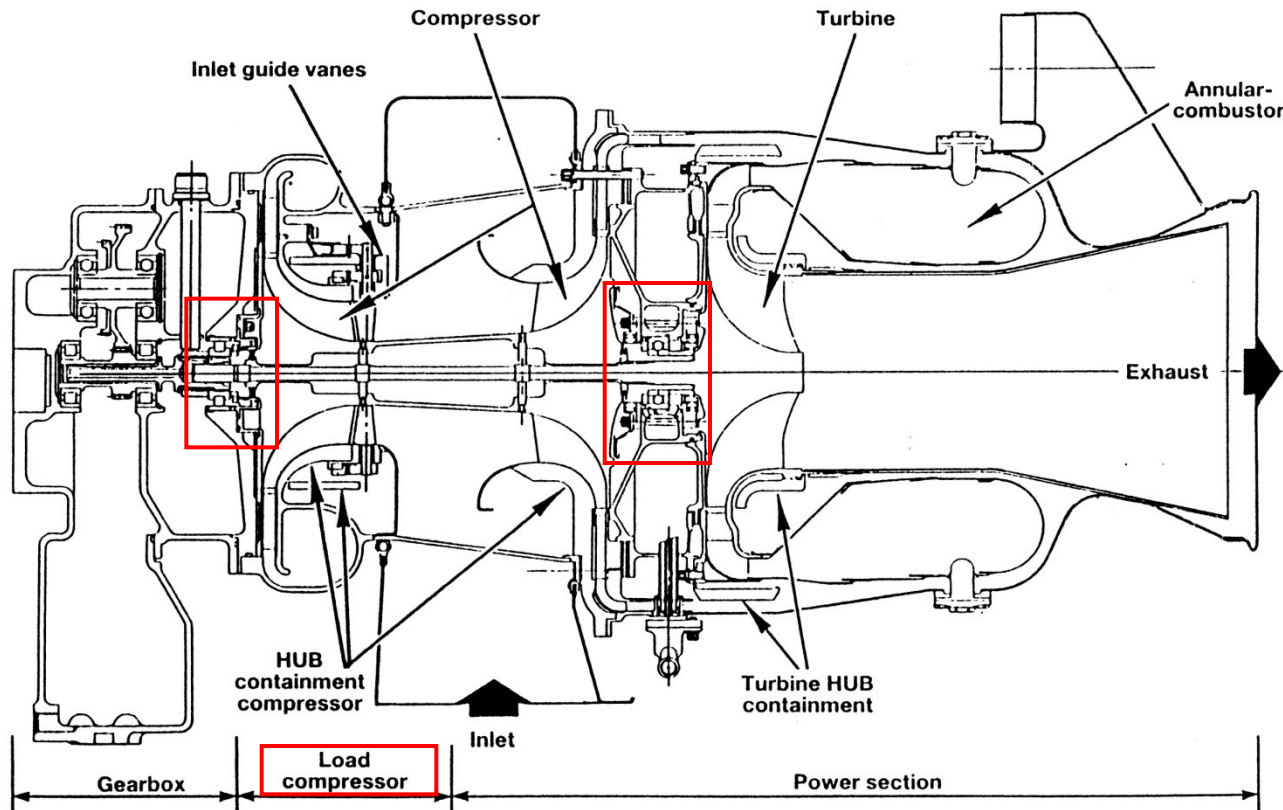

APU GTCP36-300

- An **Auxiliary Power Unit** (APU) is a gas turbine engine.
- An APU will need some form of lubrication (e.i. oil).
- Lubrication needs will be smaller than in aircraft engines, but the APU otherwise **experiences the same problems with oil leakage as described for the engine.**

(A320 GENFAM)

Auxiliary Power Unit (APU)

Bearing Components

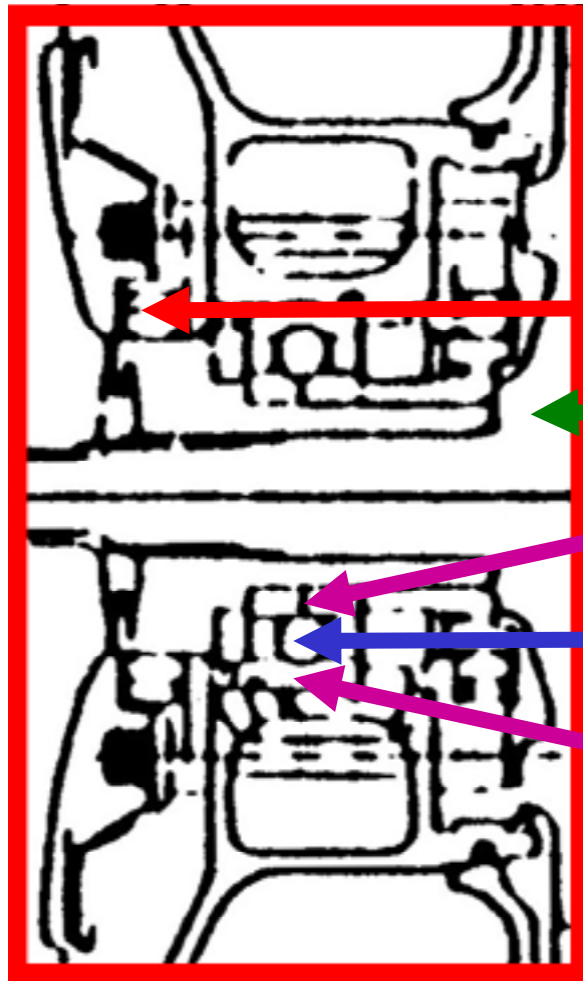

APU GTCP36-300

seal

rotating shaft

inner bearing ring

ball from ball bearing

outer bearing ring

(A320 GENFAM)

Engineering Design Principles for Air Conditioning from SAE

SAE ARP 1796: Engine Bleed Air Systems for Aircraft

(first edition 1987, A in 2007, B in 2012)



Bleed Air Quality: **Requirements** should be **imposed on the engine manufacturer** regarding the quality of the bleed air supplied to occupied compartments.

Under normal operating conditions:

The engine bleed air shall be **free of engine-generated objectionable** odors, irritants, and/or **toxic** of incapacitating foreign **materials**.

Following any type of engine ... failure, the engine bleed air shall **not contain the above substances to a harmful degree**.

... **or** bleed air systems should incorporate a **bleed air cleaner**.

Engineering Design Principles for Air Conditioning from SAE

SAE AIR 1168-7: Aerospace Pressurization System Design

(first edition: 1991, A in 2011)

“Compressor bleed from turbine engines is attractive because of the mechanical simplicity of the system.” However, “**oil contamination ... can occur in using compressor bleed air from the main engines.**” “Popular opinion regarding the risk of obtaining contaminated air from the engine **may preclude its use for transport aircraft, regardless of other reasons.**”



SAE AIR 1116: Fluid Properties

(first edition: 1992, A in 1999, B in 2013)

“**Until adequate toxicity data are available precautions** must be observed in handling any unfamiliar fluid.”

This means:

It is not the task of passengers and crew to prove that engine oils and hydraulic fluids as used today are dangerous. Just on the contrary, **industry has to prove that fluids and equipment are safe before they intend to use them**, because **standards have been agreed among engineers already long time ago, not to use bleed air on transport aircraft!**

How much Oil Gets into the Cabin?

How much Oil
Gets into the Cabin?

Think: System Boundaries

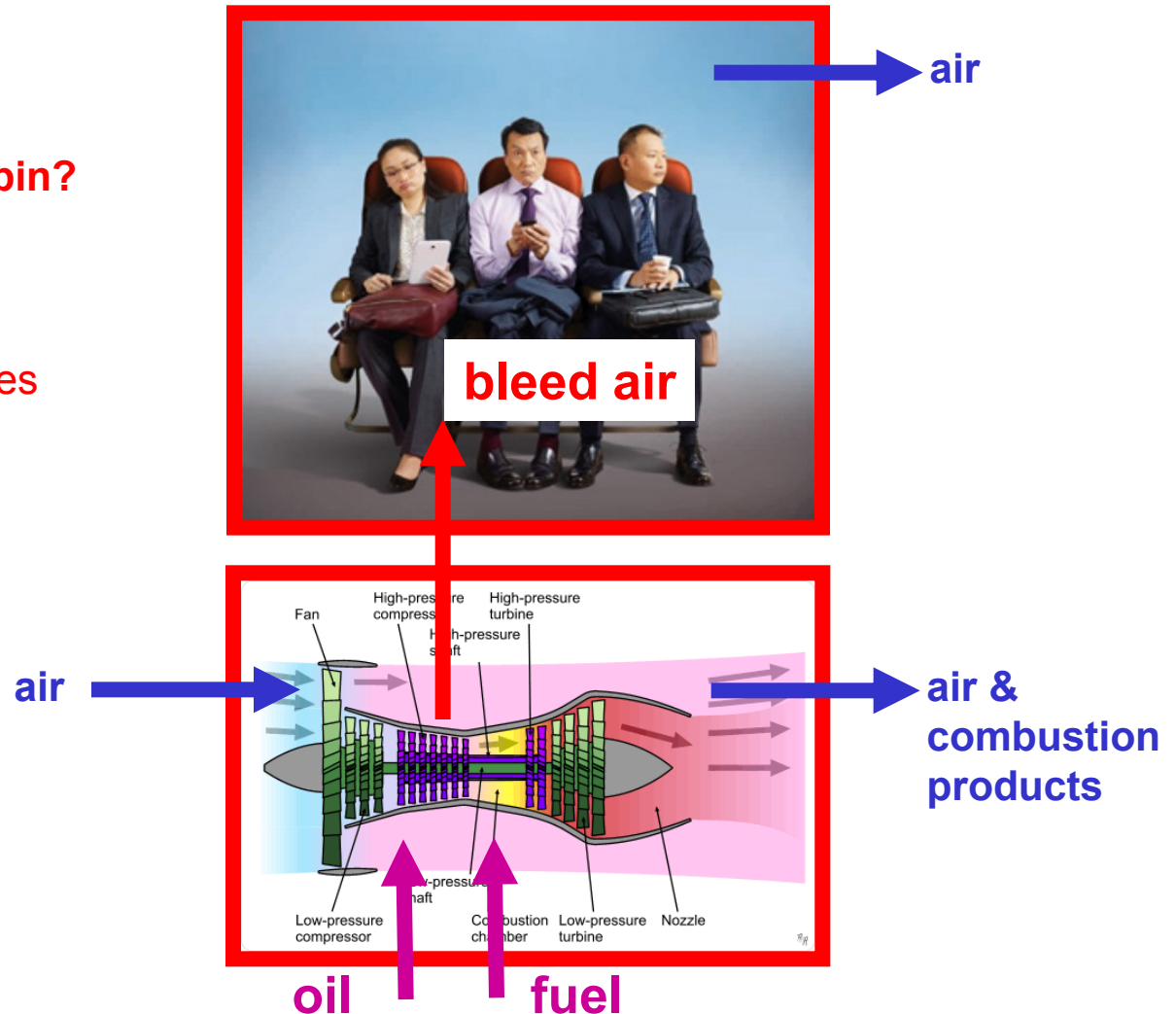

How much Oil Gets into the Cabin?

- Determine engine oil consumption per flight hour (airline maintenance records): \dot{V}_{oil}
- Estimate ratio of oil out of all seals versus the total oil out (including that oil leaving the deaerator): x_{seal}
- Determine number of all bearings or seals: n_{bear}
- Determine number of bearings or seals upstream of first bleed port: $n_{bear,up}$
- Calculate „upstream“ bearing ratio: $x_{bear,up} = n_{bear,up} / n_{bear}$
- Consider the number of engines: n_{eng}
- Get the Bypass Ratio (BPR) of the engine: μ
- Get engine frontal area from engine inlet diameter: $S_{eng} = D_{eng}^2 \pi / 4$
- Get aircraft cruise Mach number: M_{CR}
- Get aircraft cruise altitude: h_{CR}
- Get speed of sound in cruise altitude (from ISA Table or calculated): $a(h_{CR})$
- The steady state oil concentration in the cabin is equal to the oil concentration of the inflow. Finally: **Calculation of the Oil Concentration in the Cabin:**

$$\frac{m_{oil,cab}}{V_{cab}} = \frac{\dot{m}_{oil} x_{bear,up} x_{seal}}{S_{eng} n_{eng} M_{CR} a(h_{CR})} \cdot \frac{\rho_{cab}}{\rho_{CR}} (\mu + 1)$$

How much Oil Gets into the Cabin?

Background

Ramsden (2013b) proposed already in 2013 to take "jet engine oil consumption as a surrogate for measuring chemical contamination in aircraft cabin air".

However, he did neither show a derivation nor a final equation. He gives an estimate for the TCP concentration of 18 mg/m^3 . He writes: "The fact that it has been measured to be about 80000 times less ...".

This would be equal to $7,5 \text{ } \mu\text{g/m}^3$ for the total oil concentration in the air.

How much Oil Gets into the Cabin?

Derivation

The mass flow through the core of the engine can be calculated from the mass flow through the engine's inlet and the engine bypass ratio μ .

$$\mu = \frac{\dot{m}_{bypass}}{\dot{m}_{core}} \quad \dot{m}_{total} = \dot{m}_{bypass} + \dot{m}_{core} \quad \frac{\dot{m}_{total}}{\dot{m}_{core}} = \frac{\dot{m}_{bypass}}{\dot{m}_{core}} + 1 = \mu + 1 \quad \dot{m}_{core} = \frac{\dot{m}_{total}}{\mu + 1} \quad (1)$$

Oil entering the compressor through the bearing seals is a fraction, x_{seal} of the total oil consumption (oil mass flow rate). Only oil from bearings upstream of the bleed ports can enter through the bleed ports. The fraction of this oil is $x_{bear,up}$ and the oil mass flow rate approaching the bleed ports in the compressor is

$$\dot{m}_{oil,comp} = \dot{m}_{oil} x_{bear,up} x_{seal} \quad (2)$$

Some air (and oil) gets tapped off through the bleed ports. The oil concentration in the bleed flow is the same as the oil concentration in the compressor, if uniform oil distribution is assumed in the compressor. Furthermore, the oil concentration in the cabin is the same as the oil concentration in bleed flow (after steady state is reached), because cabin air is conditioned bleed air (ignoring filtered recirculated cabin air at this point). The oil concentration is calculated from the oil mass flow rate and air mass flow rate together with (1). Note, air density, has to be considered, when oil concentration is presented as mass of oil (in μg) per volume of air (m^3).

$$\frac{m_{oil,cab}}{m_{cab}} = \frac{\dot{m}_{oil,cab}}{\dot{m}_{cab}} = \frac{\dot{m}_{oil,comp}}{\dot{m}_{core}} = \frac{\dot{m}_{oil,comp}}{\dot{m}_{total}} (\mu + 1) \quad \frac{m_{oil,cab}}{V_{cab} \rho_{cab}} = \frac{\dot{m}_{oil,comp}}{\dot{V}_{total} \rho_{CR}(h_{CR})} (\mu + 1)$$

$$\frac{m_{oil,cab}}{V_{cab}} = \frac{\dot{m}_{oil,comp}}{\dot{V}_{total}} \frac{\rho_{cab}(h_{cab})}{\rho_{CR}(h_{CR})} (\mu + 1) \quad (3)$$

How much Oil Gets into the Cabin?

Derivation

Air density, ρ has to be calculated from the International Standard Atmosphere (ISA) as a function of the respective altitude, h . Cabin altitude, h_{cab} has to be less than 8000 ft (EASA CS-25).

Often $h_{cab} = 8000\text{ft}$ in cruise and as such $\rho_{cab} = 0.963 \text{ kg/m}^3$. Cruise altitude h_{CR} may be set to 11 km (tropopause) for passenger jets, if no other value is given and as such $\rho_{CR} = 0.364 \text{ kg/m}^3$.

The total flow into all engines of the aircraft is calculated from engine inlet area S_{eng} , number of engines n_{eng} and cruise speed V_{CR} .

$$\dot{V}_{total} = S_{eng} n_{eng} V_{CR} \quad (4)$$

Cruise speed is a function of cruise Mach number, M_{CR} and speed of sound, $a(h_{CR})$, which is a function of cruise altitude, h_{CR} .

$$V_{CR} = M_{CR} a(h_{CR}) \quad \text{with} \quad a = 295 \text{ m/s} \quad \text{for} \quad h_{CR} \geq 11 \text{ km} \quad (5)$$

Equations 3 with Equations 2 and 4 (making use of 5) yields

$$\frac{m_{oil,cab}}{V_{cab}} = \frac{\dot{m}_{oil} x_{bear,up} x_{seal}}{S_{eng} n_{eng} M_{CR} a(h_{CR})} \cdot \frac{\rho_{cab}}{\rho_{CR}} (\mu + 1)$$

$$a(h_{CR}) = a_0 \sqrt{\frac{T}{T_0}}$$

$$T = T_0 - L h_{CR} \quad \text{with} \quad T > 216,65 \text{ K}$$

$$L = 1.9812 \cdot 10^{-3} \text{ K/ft}, T_0 = 288.15 \text{ K}, a_0 = 340.29 \text{ m/s}$$

How much Oil Gets into the Cabin?

Example Calculation

$$\dot{V}_{oil} = 0.6 \text{ L/h both engines, } n_{eng} = 2$$

$$\rho_{oil} = 1.0035 \text{ kg/L}$$

$$\dot{m}_{oil} = 0.1673 \text{ g/s}$$

$x_{seal} = 1\%$ (conservative estimate!)

$$n_{bear} = 5 \quad \text{CFM-56}$$

$$n_{bear, up} = 3$$

$$x_{bear, up} = 0.6$$

$$\mu = 5.7$$

$$h_{CR} = 11 \text{ km} \quad a_{CR} = 295 \text{ m/s}$$

$$M_{CR} = 0.76 \quad \text{A320}$$

$$D_{eng} = 1.73 \text{ m} \quad S_{eng} = \frac{\pi}{4} D_{eng}^2$$

$$\frac{m_{oil, cab}}{V_{cab}} = \frac{\dot{m}_{oil} x_{bear, up} x_{seal}}{S_{eng} n_{eng} M_{CR} a(h_{CR})} \cdot \frac{\rho_{cab}}{\rho_{CR}} (\mu + 1)$$

$$\frac{m_{oil, cab}}{V_{cab}} = 17 \text{ } \mu\text{g/m}^3$$

How much Oil Gets into the Cabin?

Example Calculation Compared with Measurements

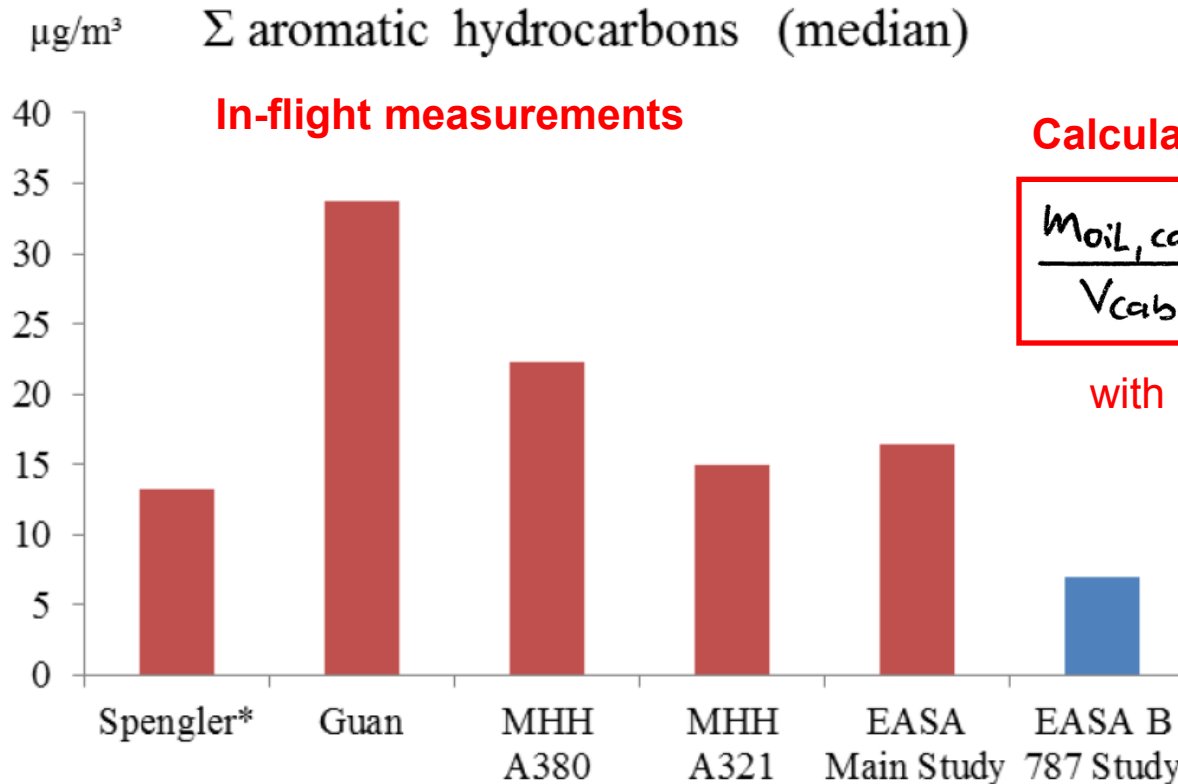

Calculated:

$$\frac{m_{oil, cab}}{V_{cab}} = 17 \mu\text{g}/\text{m}^3$$

with conservative estimate:

$$X_{seal} = 1\%$$

Σ aromatic hydrocarbons, comparison of different studies (median);
* highest values from three investigated airlines

(EASA 2017a)

Carbon Monoxide (CO) in the Cabin

CO Basics

Michaelis 2010

"Carbon monoxide (CO) may be produced as a by-product of incomplete combustion and may be generated due to thermal decomposition of contaminants entering the bleed air supply system, such as oil hydraulic fluids or deicing fluids. The CO concentration generated will be dependent upon many factors, such as airflow, the quantity of the contaminant, and the temperature of the bleed air and surfaces in contact with the contaminant."

"Carbon monoxide is an odourless, colourless and toxic gas. ... **it is impossible to see, taste or smell the toxic fumes.**"

"The effects of CO exposure can vary greatly from person to person depending on age, overall health and the concentration and length of exposure. **Acute symptoms** from CO include headaches, confusion, dizziness, nausea, weakness and **unconsciousness.**"

"Long term (chronic) exposure to low levels of carbon monoxide may produce heart disease and damage to the nervous system. Longer term effects of CO are now known to result in brain damage and cognitive impairment ... Exposure of pregnant women to carbon monoxide may cause low birth rates and nervous system damage to the offspring."

Carbon Monoxide (CO) in the Cabin

CO Related:

CS-23: Certification Specifications: Normal ... and Commuter Category Aeroplanes (and CS-25: Certification Specifications: Large Aeroplanes)

EASA CS-23: CS 23.831 Ventilation

(a) Each passenger and crew compartment must be suitably ventilated. Carbon monoxide concentration may not exceed one part in 20000 parts of air [50 ppm].

(b) For pressurised aeroplanes, the ventilating air in the flight crew and passenger compartments must be free of harmful or hazardous concentrations of gases and vapours in normal operations and in the event of reasonably probable failures or malfunctioning of the ventilating, heating, pressurisation, or other systems and equipment.

EASA CS-23: CS 23.1309(b)

The design of each item of equipment, each system, and each installation must be examined ... to comply with the following additional requirements: ...

(2) When systems and associated components are considered separately and in relation to other systems –

(i) The occurrence of any failure condition that would prevent the continued safe flight and landing of the aeroplane must be extremely improbable; and

(ii) The occurrence of any other failure condition that would significantly reduce the capability of the aeroplane or the ability of the crew to cope with adverse operating conditions must be improbable.

Remark: A table relating Probability of Failure and Effect of Failure – like the one in AMC 25.1309(b) – does not exist here.

EASA CS-23: CS 23.1309(b)(3)

Warning information must be provided to **alert the crew to unsafe system operating conditions** and to enable them to take appropriate corrective action.

EASA CS-25: CS-25.1309(c)

Information concerning unsafe system operating conditions must be provided to the crew to enable them to take appropriate corrective action. A warning indication must be provided if immediate corrective action is required.

(For an extensive discussion of CS-25 with respect to bleed air see "Immediate Health Effects – Flight Safety Implications".)

Carbon Monoxide (CO) in the Cabin

CO Related Accidents with General Aviation (GA) Aircraft

FAA 2009a

As much as 62 CO related accidents were identified between 1962 and 2007 from a reviewed of the National Transportation Safety Board (NTSB) database ($\approx 1,4$ per year in the USA alone). Although there are more reasons for CO poisoning, the most **problematic component** is the **heat exchanger** in the heating/exhaust system. Fresh air for the cabin moves along the surface of the muffler. Any crack or hole in the muffler can allow exhaust gas with CO to contaminate the cabin air. To improve the situation, maintenance practice (crack finding), lifetime limits for mufflers, and use of a suitable CO detector, would serve as a method to prevent CO exposure in GA aircraft. None of this is demanded by FAA.

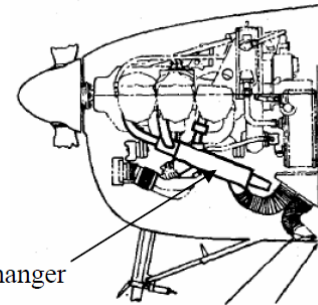

CO detectors using electrochemical sensors may be the most suitable technology for use at this time in a GA environment. Electrochemical CO detectors available on the market that are likely suitable for use in a GA environment range in price from 175 US\$ to 200 US\$, possess good battery life (2000 h to 2600 h), and have quick response times (12s to 35s). Collectively considering the advantages and limitations of the various CO detector technologies, electrochemical sensors appear to be the most suitable for a GA environment due to their relatively high accuracy, quick response time, inherent immunity to false alarms, and low power consumption. The instrument panel appeared to be the best location for the placement of CO detectors.

NTSB 2004

The National Transportation Safety Board recommends that the Federal Aviation Administration [should] require the installation of carbon monoxide (CO) detectors ... in all single-engine reciprocating-powered airplanes with forward-mounted engines and enclosed cockpits ... (A-04-28) *Remark: But the FAA did not require mandatory CO detectors.*

AOPA 2004

According to the Aircraft Owners and Pilots Association (AOPA), mandatory carbon monoxide (CO) detectors in piston-powered single-engine aircraft would do little to lower the general aviation (GA) accident rate. AOPA only found "just" **one accident per year due to CO** (in the USA). The low-cost (≈ 10 US\$) opto-chemical CO detector cards found in many aircraft are usually not promptly replaced when past their recommended useful life and are most effective only when very high levels of CO enter the cockpit.

Carbon Monoxide (CO) in the Cabin

CO Detectors

FAA 2017

A Technical Standard Order (TSO) is a minimum performance standard for specified materials, parts, and appliances used on civil aircraft. When authorized to manufacture a material, part, or appliances to a TSO standard, this is referred to as TSO authorization. Receiving a TSO authorization is both design and production approval. Receiving a TSO Authorization is not an approval to install and use the article in the aircraft. It means that the article meets the specific TSO and the applicant is authorized to manufacture it. *Remark: The existence of a TSO does not mean this equipment has to be used.*

FAA 2009b

TSO C48a "Carbon Monoxide Detector Instruments" applies to equipment that detect CO and emits a warning when levels become dangerous. The TSO points to SAE AS-412A for most technical details.

EASA 2003

"European Technical Standard Orders" contains ETSO C48: "Carbon Monoxide Detection Instruments" which points for further requirements to SAE AS-412A: "Carbon Monoxide Detector Instruments".

SAE AS-412

"Carbon Monoxide Detector Instruments". The Aeronautical Standard covers the basic type of carbon monoxide detector instrument used to determine toxic concentrations of carbon monoxide by the measurement of heat changes through catalytic oxidation.

There are **four types of CO sensors** available:

- Opto-chemical (color spot, blob): A pad of a colored chemical which changes color upon reaction with carbon monoxide.
- Biomimetic (colorimetric): An LED shines through a colored chemical detector onto a photocell.
- Electrochemical: An electrochemical cell consisting of a container, two electrodes and electrolyte.
- Semiconductor: Tin dioxide on a ceramic base heated to 400 °C. *See also SAE AS-412A.*

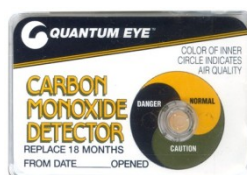

Example of a digital electrochemical CO detector:

- Display range: 7 PPM to 100 PPM
- Dimensions: diameter 6cm, thickness: 4 cm
- Powered by: 2 AAA batteries

AEROMEDIX *CO Experts ULTRA*

Carbon Monoxide (CO) in the Cabin

CO in Passenger Aircraft Cabins

Normal Situation

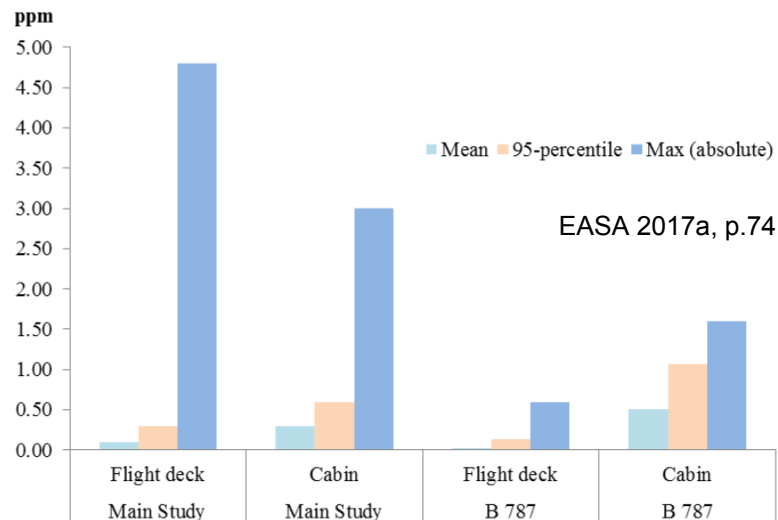

The CO level in normal operation is much lower than the limit of 50 ppm (specified in CS 23.831 and CS 25.831). Failure cases did not occur during these measurements.

CO: $1 \text{ mg/m}^3 = 0.87 \text{ ppm}$ (at 25°C) (EASA 2017a, p. 73)

Failure Case: Fume Event



US Airways Flight 432 Phoenix to Maui, B757, 17.09.2010 (Aviation Herald 2010). Video on: <https://goo.gl/4wAwtZ>

EASA 2017b (p. 75 - 77)

"Until the oil has reached 180°C hardly any emission of CO arises. However, it appears that following the increase of temperature of the oil from 180°C to 375°C , CO emissions are formed due to incomplete combustion of the oil." "[At 375°C] the CO concentration is increasing severe[ly]." "It is not meant that results of our work can be up-scaled, neither be related to typical aircraft ... [nor] engines."

Air in the compressor reaches more than 500°C . So, we know much **CO is present in the cabin during a Fume Event. The exact concentration is only known when measured during the event. Therefore, pilots should by all means carry their personal CO detector and make decisions accordingly!**

Carbon Monoxide (CO) in the Cabin

Conclusions

Carbon Monoxide / Bleed Air / CO Detectors / CO-Related GA Accidents / CS-23

When comparing the text of CS-23 and CS-25 with respect to §831(a)(b) and §1309(3)(b) / §1309(c) it is found that the legal situation is almost the same for general aviation aircraft (certified in accordance with CS-23) and for large aeroplanes (certified in accordance with CS-25).

CO detectors have NOT been made mandatory (neither for CS-23 nor for CS-25 aircraft). It only has become common practice by owners of piston engined small aircraft to fit inexpensive (unfortunately also quite ineffective) opto-chemical ("color spot") CO detectors. As long as pilots do not include these detectors regularly into their instrument scan they are of no use. Usually high pilot workload especially in demanding flight situations will most probably not allow them for scanning the CO detector and the detectors color change will pass unnoticed.

It is inappropriate to compare

- a) the situation (related to cabin air contamination due to CO) of single piston engined aircraft (heat exchanger) with
- b) the situation (related to cabin air contamination due to bleed air) of jet powered passenger aircraft (bleed air).

We can only learn here that a large resistance exists (in the aviation industry) to changes of standard legal practice (that demands additional money or effort).

Pilots concerned about cabin air contamination should no longer wait for legal / manufacturer's / airline's action. Instead, pilots should carry their personal digital CO detector on board and should take safety precautions in accordance to measurements from these devices.

Acute symptoms of CO and TCP poisoning have some similarity. CO as well as TCP poisoning can lead to pilot incapacitation. The situation is aggravated by the many other dangerous constituents of pyrolyzed engine oil. It is clear that also larger quantities of oil can get into the cabin during engine malfunctions (as seen in fume events). Elevated readings from a CO detector should be taken as indicative of a more general cabin air problem endangering the pilot's level of alertness.

Engine Oil Detected on its Way into the Cabin

The Engine Oil has left Traces on its Way from the Bleed Port into the Cabin

Bleed Duct (Oil Residue Accumulated)



Visual inspection of a bleed air off-take port from a Boeing 737. The interior is black from oil contamination. (GCAQE 2017)

Engine Oil Detected on its Way into the Cabin

The Engine Oil has left Traces on its Way from the Bleed Port into the Cabin

Air Conditioning Ducts (Investigating the BAe 146)



a) new

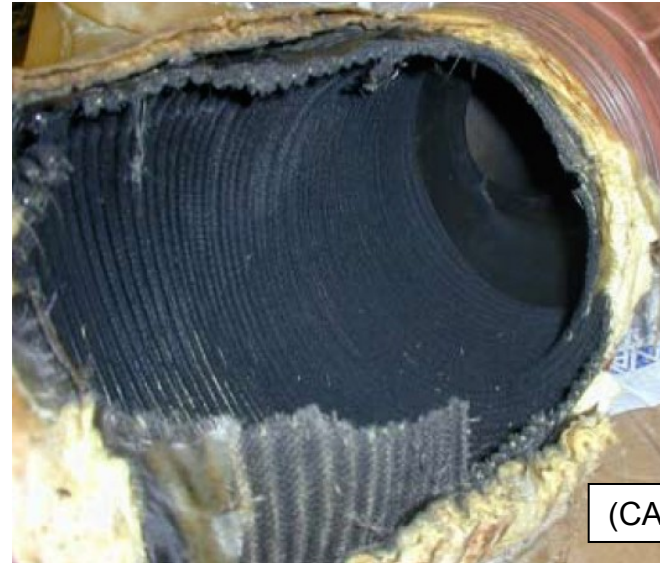

b) used (26000 FH)

On cutting the duct open [the used duct], the lagging was found to be saturated with a green/yellow liquid which could be mobilised by applying gentle pressure to the duct. The duct had an associated acrid odour.

Engine Oil Detected on its Way into the Cabin

The Engine Oil has left Traces on its Way from the Bleed Port into the Cabin

Cabin Surfaces (Wipe Samples)

A glass fibre filter [cloth] was moistened with a small quantity of ethanol (approximately 10 drops) using a clean glass pipette dropper. The filter was then used to wipe the area within the aperture in a set pattern to ensure consistent and effective removal of any surface contamination. The filter was folded between each segment of the pattern to provide a clean collection surface. The wiping pattern consisted of one wipe clockwise round the four edges of the aperture in sequence, followed by five vertical wipes across the width of the aperture, with a final pass of ten horizontal wipes covering the vertical aspect of the aperture.

A total of seventeen aircraft, five airport-based vehicles and two offices were evaluated, with a total of eighty six locations sampled. TBP, BDPP and DBPP measured in the surface deposits from the cockpits of aircraft were in general higher than those from the passenger areas. **The amount of TCP measured was higher in planes than in other locations, suggesting that this substance originated from aircraft sources.**

(Lamb 2012)

See also: Solbu 2011

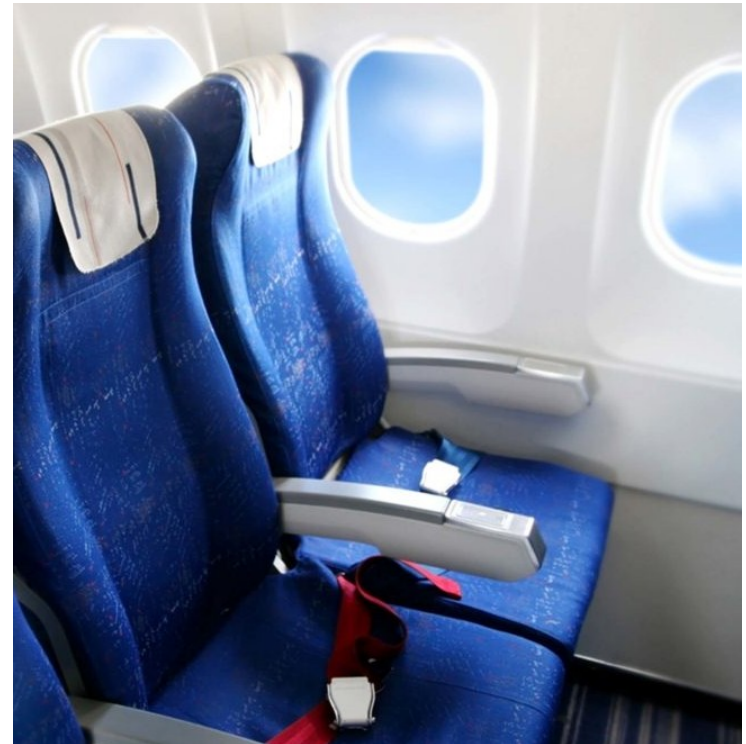

	Aircraft				
	B737	B757	B767	Airbus	BAe 146
Measured TCP Maxima (all wipes per sample) by Aircraft Type/ng	930	13000	4800	260	1500

Engine Oil Detected on its Way into the Cabin

The Engine Oil has left Traces on its Way from the Bleed Port into the Cabin

Recirculation Filters

(Airlines Deliver Filters Anonymously)

... to test 184 used aircraft filters with ... [gas chromatograph](#) - mass spectrometry system

107 were standard filters, and 77 were nonstandard. A nonstandard filter is a filter that was typically removed from an aircraft before its normal service life because of chronic air-quality complaints or an unspecified air-quality incident on the aircraft.

Four of the standard filters had both markers for oil, ... It was also found that **90% of the filters had some detectable level of tricresyl phosphates [TCP]**.

Of the 77 nonstandard filters, 30 had ... markers for oil, a significantly higher percent than the standard filters.

(Eckels 2014)



High Efficiency Particulate Air (HEPA) Filter used in the cabin air recirculation loop.

(Pall 2016)

Measures in Aircraft Operation / Hints for Pilots

What to Do: Ground Operation

Aircraft parked

- Conditioned air from the airport can be used. The air goes directly into the cabin.
- Pressurized air from the airport may be used, if it is from a central supply (and not from an APU mounted ground cart). The air only goes through the packs that are usually not a reason for cabin air contamination.

Engine start and shut down

- Engine bleed valves may be switched off during these moments or the APU may be used.

Taxi

- The engine bleed valves can be switched off during taxi when badly smelling air enters the cabin apparently e.g. from a (traffic) situation with exhaust gas ingestion from other aircraft.

What to Do: Fume Event or Elevated Readings from a CO Detector

1. The checklist has to be consulted. It will guide the pilots through all possibilities of experienced smoke in a systematic way.
2. The checklist will most probably demand the pilots to wear oxygen masks. (Michaelis 2010 evaluated the checklists of various aircraft for "Smoke" or "Cabin Air Contamination").
3. With respect to engine oil contamination: Pilots should determine the source of the contamination by switching off single engine bleed valves at a time. In normal flight the bleed air will come from the engines.
4. If no engine can be determined as the source of the contamination, pressurized air from the APU should be used.
5. If also this does not help, pilots should determine the source of the contamination by switching off single packs at a time. (Note: 3., 4., and 5. may lead to a large number of cases especially with 4-engined aircraft. Furthermore, Cross Bleed Valves and Trim Air Valves make things even more complicated. Therefore, it may be necessary to jump directly to 6.)
6. Landing at the nearest alternate airport is an option.
7. If the contamination of the cabin air is quite bad and none of the preceding options offer a solution to the problem, **direct venting of the cabin should be considered. This option is only available, if terrain clearance allows a descent down to 10000 ft. Cabin pressurization will be lost, but 10000 ft cabin altitude is acceptable in this situation. Cruise Mach number has to be reduced considerably otherwise very high fuel burn will result.** The Flight Management System (FMS) or other sources of information need to be accessed for performance calculation in order to optimize for cruise Mach number in light of required range and fuel reserves.

Measures in Aircraft Operation / Hints for Pilots

Direct Venting of the Cabin in 10000 ft

The cruise Mach number has to be reduced considerably otherwise very high fuel burn will result

- The aircraft is designed for a certain cruise lift coefficient that should be kept constant.
- If the altitude is reduced, the aircraft flies in air with higher density. This has to be compensated
 - by lower **cruise speed in 10000 ft, V_{10k}** (given as True Air Speed, TAS) compared to original cruise speed at cruise altitude, V_{CR} or
 - by lower **Mach number in 10000 ft, M_{10k}** compared to original Mach number at altitude, M_{CR} .
- Although speed /Mach number are correctly reduced, **range in 10000 ft, R_{10k}** is still less than original range at cruise altitude, R_{CR} .
- Calculated is a conservative estimate of range reduction, because drag reduction due to Mach number reduction has not been considered.

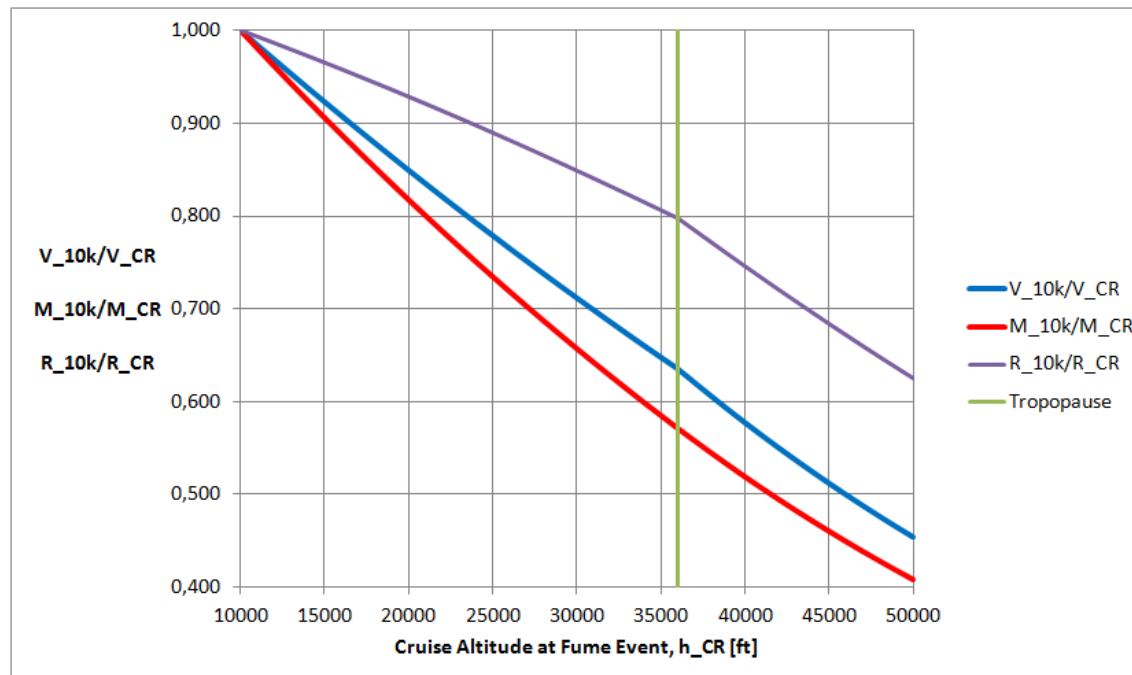

R_{10k}/R_{CR} calculated for
 $M_{CR} = 0,76$

Note: There is little change for
other cruise Mach numbers.

Measures in Aircraft Operation / Hints for Pilots

Derivation: Direct Venting of the Cabin in 10000 ft

Derivation of Equations (see considerations on previous page)

- cruise speed in 10000 ft, V_{10k} (TAS)
- Mach number in 10000 ft, M_{10k}
- range in 10000 ft, R_{10k}

$$L = mg = \frac{1}{2} \rho V^2 \cdot c_L \cdot S_w = \text{const}$$

$$S_{CR} \cdot V_{CR}^2 = S_{10k} \cdot V_{10k}^2$$

$$V_{10k} = \sqrt{\frac{S_{CR}}{S_{10k}}} \cdot V_{CR}$$

$$M_{10k} \cdot a_{10k} = \sqrt{\frac{S_{CR}}{S_{10k}}} \cdot M_{CR} \cdot a_0 \cdot \sqrt{\frac{T_{CR}}{T_0}}$$

$$M_{10k} = \sqrt{\frac{S_{CR}}{S_{10k}}} \cdot \frac{a_0}{a_{10k}} \cdot \sqrt{\frac{T_{CR}}{T_0}} \cdot M_{CR}$$

$$S_{10k} = 0,90464 \text{ kg/m}^3 \quad a_{10k} = 328,39 \text{ m/s}$$

$$T_0 = 288,15 \text{ K} \quad a_0 = 340,29 \text{ m/s}$$

Plot:

$$\frac{V_{10k}}{V_{CR}} = \sqrt{\frac{S_{CR}}{S_{10k}}}$$

$$\frac{M_{10k}}{M_{CR}} = \sqrt{\frac{S_{CR}}{S_{10k}}} \cdot \frac{a_0}{a_{10k}} \cdot \sqrt{\frac{T_{CR}}{T_0}}$$

Calculating the reduced range:

$$R = \frac{E \cdot V}{c \cdot g} \cdot \ln \frac{m_1}{m_2} \quad c = c_a V + c_b$$

$$\frac{R_{10k}}{R_{CR}} = \frac{V_{10k}}{V_{CR}} \cdot \frac{c_{CR}}{c_{10k}} = \frac{V_{10k}}{V_{CR}} \cdot \frac{c_a \cdot V_{CR} + c_b(h_{CR})}{c_a \cdot V_{10k} + c_b(h_{10k})}$$

$$= \frac{V_{10k}}{V_{CR}} \cdot \frac{c_a \cdot M_{CR} \cdot a_{CR} + c_b(h_{CR})}{c_a \cdot M_{10k} \cdot a_{10k} + c_b(h_{10k})}$$

$$a_{CR} = a_0 \cdot \sqrt{\frac{T_{CR}}{T_0}} \quad M_{10k} = \frac{M_{10k}}{M_{CR}} \cdot M_{CR}$$

$$c_a = 3,38 \cdot 10^{-8} \text{ kg/(Nm)} \quad c_b = 1,04 \cdot 10^{-5} \sqrt{\frac{T_0}{T(h)}} \text{ kg/(Ns)}$$

Solutions



Engine Oil Developments

- The extrem working environment of a jet engine needs special additives. Unproblematic additives have not been found so far.
- **TOCP content has been much reduced over last decades.** TOCP seems not to be used deliberately any more, but can be in the oil occasionally in very small quantities.
- **Toxic DOCP and MOCP are not properly reported.** It is unlikely that good news is hidden. It is evident that air crew showed signs of TCP poisoning. If in doubt **caution is mentatory.**
- If the oil gets pyrolyzed the situation gets worse, certainly not much better.
- In the same way as decades ago: **Engine oil should not get into the aircraft cabin.**
- **NYCO** offers a jet engine oil without TCP:

TURBONYCOIL 600 (Petro-Canada 2017)

Chemical name	CAS-No.	Concentration
Phenol, isopropylated, phosphate (3:1)	68937-41-7	1 - 5 %
N-1-naphthylaniline	90-30-2	0.1 - 1 %

Harzard Codes of the "Phenol, isopropylated, phosphate (3:1)" (DURAD 150) are:

H361: Suspected of damaging fertility or the unborn child if swallowed.

H411: Toxic to aquatic life with long lasting effects.

R48/22: Harmful: danger of serious damage to health by prolonged exposure if swallowed.

R62: Possible risk of impaired fertility.

R63: Possible risk of harm to the unborn child.

Also NYCO's oil is not without risk.



Solutions

Sensors to Detect TCP and VOC

aerotracer (Airsense 2017)

- offered for sale.
- detects 15 substances: grease, liquid, gas: engine oils, de-icing fluids, hydraulic fluids, corrosion inhibitors, glue, heat transfer fluid, kerosene, ...
- power supply: 110 to 240 VAC; 30 W or rechargeable battery (operating time 4 hrs).
- electronics: graphical display, Mini SD Card.



VN Aerotoxic Detection Solutions (VN-ADS) (Aircraft Interiors 2017)

- prototypes are tested.
- Company claims to have the world's first real-time detector of poisonous compounds in aircraft cabins. (Aircraft Interiors 03/2017)
- Mono Fibre Optical Measuring Technology (MOMT) ... have demonstrated the capability to detect Tricrysel Phosphate (TCP) and other Volatile Organic Compounds (VOCs) and Semi Volatile Organic Compounds (SVOCs) in real time.

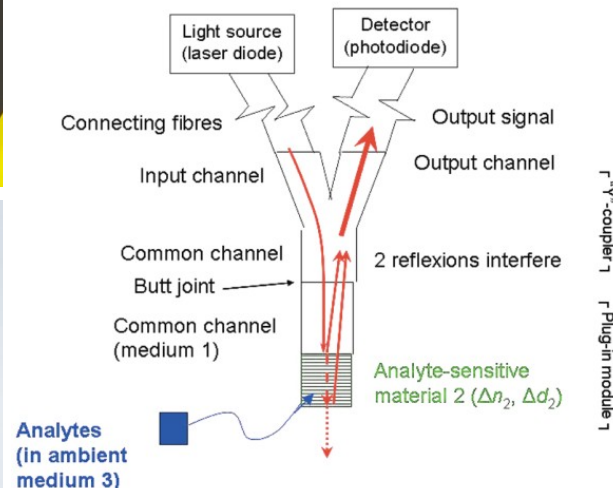

Measurement of hydrocarbon content (ppm- and ppb-level)

- Measuring the (unaltered) bleed air from an APU at HAW Hamburg,
- Checking the sensitivity of the equipment with pyrolyzed aviation fluids. Gröger und Obst GmbH, 2014. The equipment is still too large (blue rack) for easy integration into the aircraft. See also: Reiss 2016.

Solutions

Filters to Remove TCP and VOC

Pall has **several treatment** solutions for cabin air on offer:

- Carbon Filter
- Photo Catalytic Oxidization (with UV light)
- Catalytic Converters (oxidization). Location is possible:
 - upstream of the pack,
 - downstream of pack,
 - at recirculation filter
(reduced efficiency compared to a filter in line with the pack – see next page)



Such a filter is recommended to protect against chemical weapons, but it is (so far) not intended to be used on aircraft.

Pall offers **Odour/VOC Removal Filters**

- The carbon adsorbent is effective at adsorbing volatile organic compounds (VOC). Test results have shown a removal efficiency of 65% ... 73% when challenged with TCPs in the gaseous phase. Carbon adsorbents have some effectiveness with ozone but not with carbon monoxide (CO). Removal of these compounds from the cabin air is by adsorption on to carbon based filters. (Pall 2011)

Application of carbon filters:

- 33 HEPA-Carbon filters have been added (so far) to A321 aircraft at Lufthansa Group. (Lufthansa 2017)
- Pall carbon filters are installed on the B757 cargo fleet of DHL. Carbon filters are installed in place of the air ducts leading to the cockpit. EASA issued an STC for the installation. (EASA 2010)

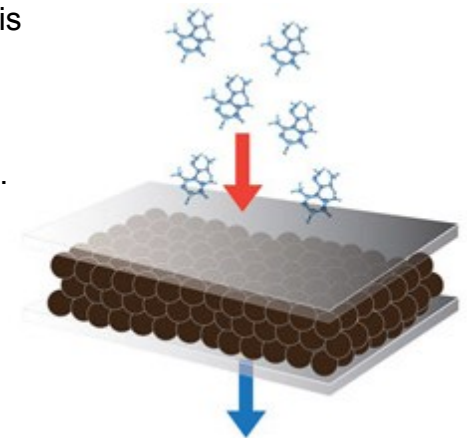

Schematic of carbon Filter (Pall 2011)

Solutions

But: How Efficient are Filters in the Recirculation Path?

Example calculation:

- The Pall carbon adsorbent is effective at adsorbing volatile organic compounds with a removal efficiency of 65% ... 73% when challenged with TCPs in the gaseous phase. (Pall 2011)
- The A320 has a recirculation rate of 50%.
- With a filtration rate, $x_{fil} = 0,7$ and a recirculation rate, $x_{re} = 0,5$ the filter reduces the incoming concentration to 58,9%.

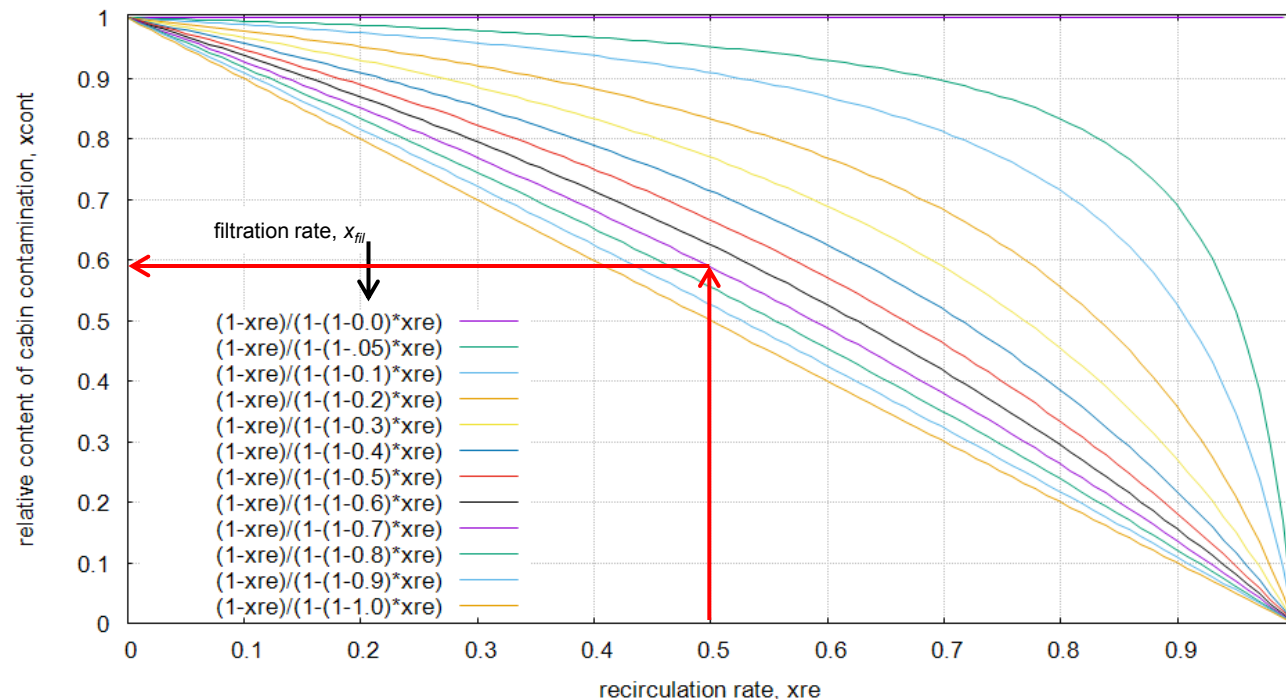

$$\frac{x_{cont,cab}}{x_{cont,in}} = \frac{1 - x_{re}}{1 - (1 - x_{fil})x_{re}}$$

for $x_{fil} = 1$:

$$\frac{x_{cont,cab}}{x_{cont,in}} = 1 - x_{re}$$

Solutions

Derivation: Efficiency of Filters in the Recirculation Path

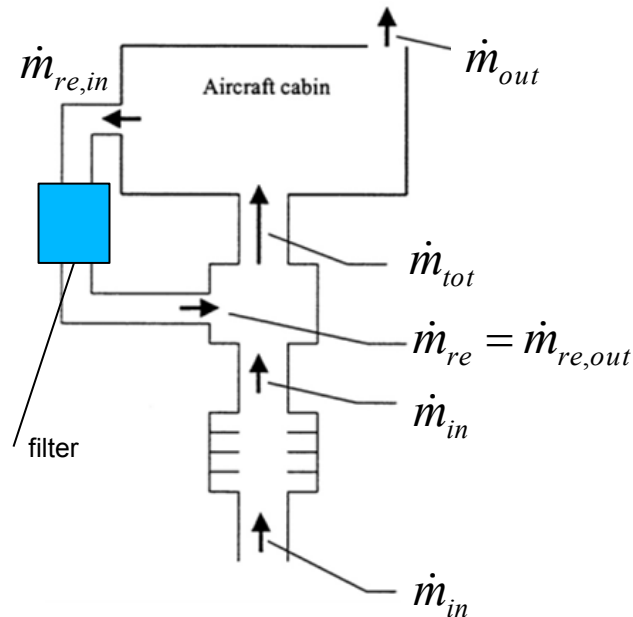

Adapted from (NRC 2002)

$$\dot{m}_{out} = \dot{m}_{in}$$

$$\text{Def.: } \frac{\dot{m}_{re}}{\dot{m}_{tot}} = X_{re}$$

$$\dot{m}_{tot} = \dot{m}_{in} + \dot{m}_{re}$$

$$\dot{m}_{re} = X_{re} \cdot \dot{m}_{tot}$$

$$\dot{m}_{tot} = \dot{m}_{in} + X_{re} \cdot \dot{m}_{tot}$$

$$\dot{m}_{tot} = \frac{\dot{m}_{re}}{X_{re}} \quad (1)$$

$$1 = \frac{\dot{m}_{in}}{\dot{m}_{tot}} + X_{re}$$

$$\frac{\dot{m}_{in}}{\dot{m}_{tot}} = 1 - X_{re}$$

$$\dot{m}_{tot} = \frac{\dot{m}_{in}}{1 - X_{re}} \quad (2)$$

$$\dot{m}_{tot,cont} = \dot{m}_{in,cont} + \dot{m}_{re,out,cont} \quad (3)$$

cont: contaminated

$$\text{Def.: } \frac{\dot{m}_{in,cont}}{\dot{m}_{in}} = X_{cont,in}$$

$$\frac{\dot{m}_{out,cont}}{\dot{m}_{out}} = \frac{\dot{m}_{tot,cont}}{\dot{m}_{tot}}$$

$$\dot{m}_{re,out,cont} = (1 - X_{fil}) \dot{m}_{re,in,cont}$$

$$X_{cont,cab} = \frac{\dot{m}_{re,in}}{\dot{m}_{re}}$$

with (3)

$$\frac{\dot{m}_{tot,cont}}{\dot{m}_{tot}} = \frac{\dot{m}_{in,cont}}{\dot{m}_{in}} + (1 - X_{fil}) \frac{\dot{m}_{re,in,cont}}{\dot{m}_{re}}$$

Solutions

Derivation:

Efficiency of Filters in the Recirculation Path

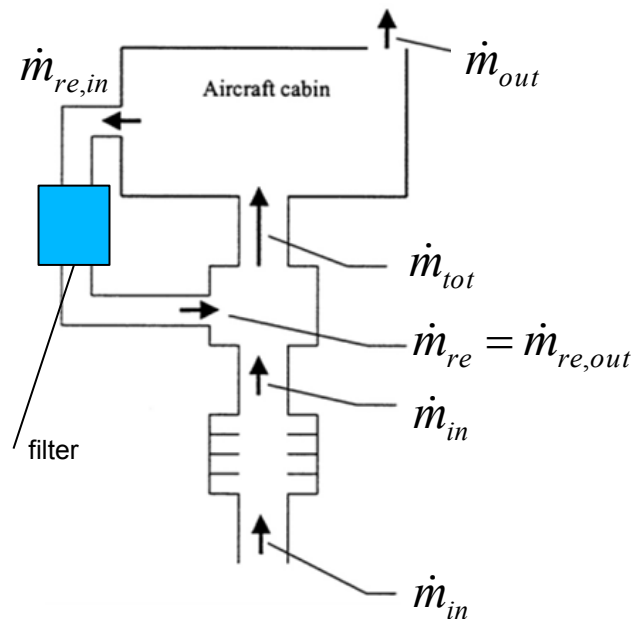

$$x_{cont,cab} = x_{cont,in} (1 - x_{re}) + (1 - x_{fil}) \cdot x_{re} \cdot x_{cont,cab}$$

$$x_{cont,cab} (1 - (1 - x_{fil}) x_{re}) = x_{cont,in} (1 - x_{re})$$

$$\frac{x_{cont,cab}}{x_{cont,in}} = \frac{1 - x_{re}}{1 - (1 - x_{fil}) x_{re}}$$

for $x_{fil} = 1$:

$$\frac{x_{cont,cab}}{x_{cont,in}} = 1 - x_{re}$$

Adapted from (NRC 2002)

Solutions

Air Sampler for Later Air Analysis



Prof. Van Netten invented this "VN-Sampler". It is not an in situ measurement device, but a means to collect the air in a fume event for later detailed analysis in a laboratory on the ground. The device is FAA approved.

(Van Netten 2008)

Solutions

Cabin Pressurization Principles and Solutions

Overview

- **First Jet Aircraft** used a "blower" or "**turbocompressor**" (TC). The TC is the coupling of a turbine with a compressor. Bleed air from the engine compressor drives the TC turbine. The TC's compressor compresses outside air to meet the pressurization requirements of the cabin. The hot compressed air needs to be cooled. This can be done with a "vapor cycle system" (as known from the refrigerator).
- **Current Aircraft** make **use of bleed air directly**. It is compressed so much that it contains enough energy to also drive the pack that cool the bleed air down to temperatures considerably less than 0°C.
- The **Boeing 787** uses electrical power to drive an electric motor to drive a compressor. The **energy is extracted from the engine by means of shaft power driving a generator**. No bleed air is used. The engine is "Bleed Free".

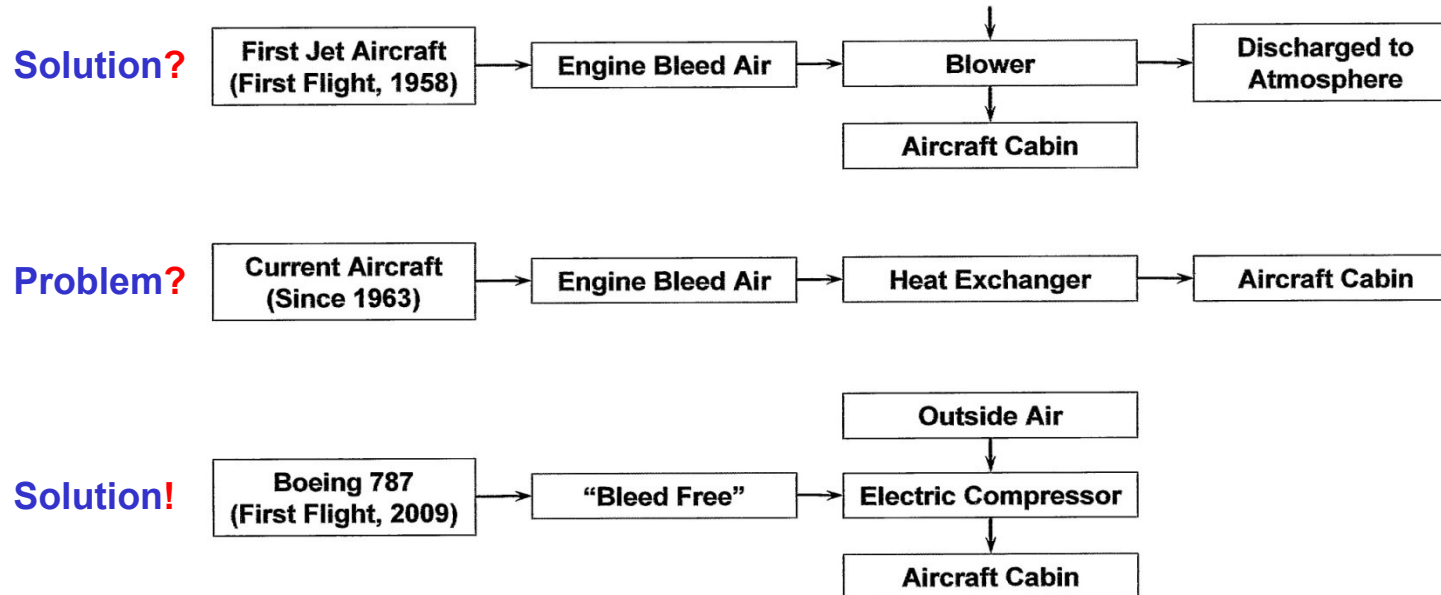

(Michaelis 2010)

Solutions

Aircraft with Turbochargers

Solution DC-8?

- Bleed air was used to power a turbocharger, which compressed the ram air to the proper pressure. That air was cooled by a Freon vapor compression-cycle air conditioner for temperature control before being distributed to the cabin. The arrangement was **heavy, expensive**, and inefficient because of the **inefficiencies of the turbocharger** (E. Marzolf, retired, Douglas Aircraft Co.) (NRC 2002)
- Even more important was the **high amount of maintenance** that the systems required (R. Kinsel, retired, AlliedSignal) (NRC 2002)
- The inlets on the front of the DC8 are for the 4 turbochargers [TC's] used to pressurize the cabin. The top and bottom inlets feed the turbo compressors. [The middle inlet] feeds heat exchangers to cool the compressed air from the TC's. The bleed air from the engines which is used to spin the turbo compressors exhausts overboard from the vent located on the side of the fuselage [only a little] aft [and a little higher]. (Jetpilot 2001)
- "The TC's on the DC8 were extremely noisy in the cockpit, and had a tendency to have uncontained [rotor] failures which scared the shit out of you as the pieces had a tendency to rip into the cockpit on occasion. To find the condition of a TC on the preflight one only had to **look at the TC exhaust duct and find how much oil from the bearing case had leaked past the seal and run all over the fuselage**. I never saw a TC that didn't leak. They also made strange noises notifying you of their impending doom." "TC's spool up to about 13000 RPM in about 2 seconds." (Jetpilot 2001)



DC-8 (Airline Ratings 2017)

Solutions

Aircraft with Turbochargers

Solution B707?

- The B707 engines are Pratt and Whitney JT3C's. Unlike modern passenger jet engines, they are not equipped to provide air for cabin pressurization. So for cabin air purposes, you need one of the key 707 spotting features - the turbochargers. The turbocharger is basically a little engine-driven turbine that sits right above the engine's fan casing, just ahead of the pylon. For obvious reasons, Boeing put a nice little fairing over the turbocharger (TC) and faired it into the pylon. But it leaves an obvious "hump" on top of the engine just in front of the pylon. A TC hump doesn't necessarily mean there's a TC in there. Some B707 have 4 TC humps, others only have 2 TC's. The other two are empty humps. Engines 2 and 3 have the humps, 1 and 4 don't. AA's B707 have only 2 TCs and only 2 humps. (Hingten 2004)
- Inlets to TCs usually appear only on the number 2, 3, and 4 engines and generally not on the number 1 engine.
- The reason for only three turbochargers is that only 3 were required for adequate pressurization and redundancy.
- The smaller non-intercontinental - non ocean crossing 707 sister, the 720, had only two turbochargers. They are found on #2 and #3 engines only. Less redundancy needed for mostly overland flight with closer diversion airports.
- A volume of air was bled off the engine to turn the turbocharger supplying the aircrafts pressurization needs. The engine bleed air was then dumped overboard once it powered the turbochargers turbine. There is a small opening on the side of the upper nacelle just behind the turbocharger. That is the turbine exhaust.
- There were also concerns about engine oil contaminating the air conditioning system if the air was bled directly off the engine.
- Engine bleed air can be used to supplement a TC should it shutdown or be subject to a MEL, or in addition if extra airflow is required. (Airliners 1999)

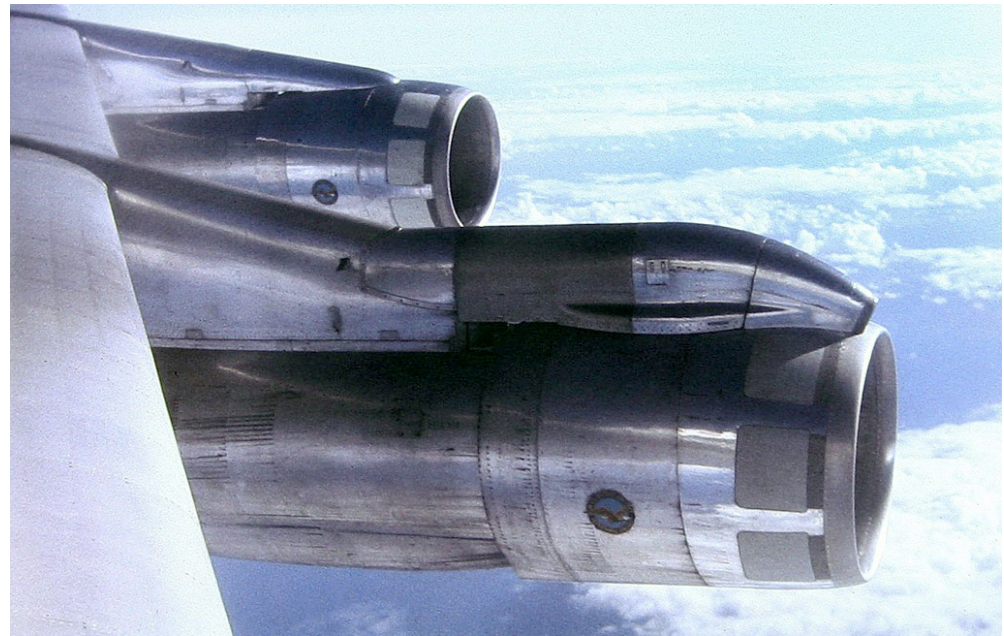

B707-320C with Pratt & Whitney JT3D engines (Wikipedia 2017b)

Technical Solutions

Electrical (Bleed Free) Cabin Air Supply Solution B787!

(Boeing 2007)

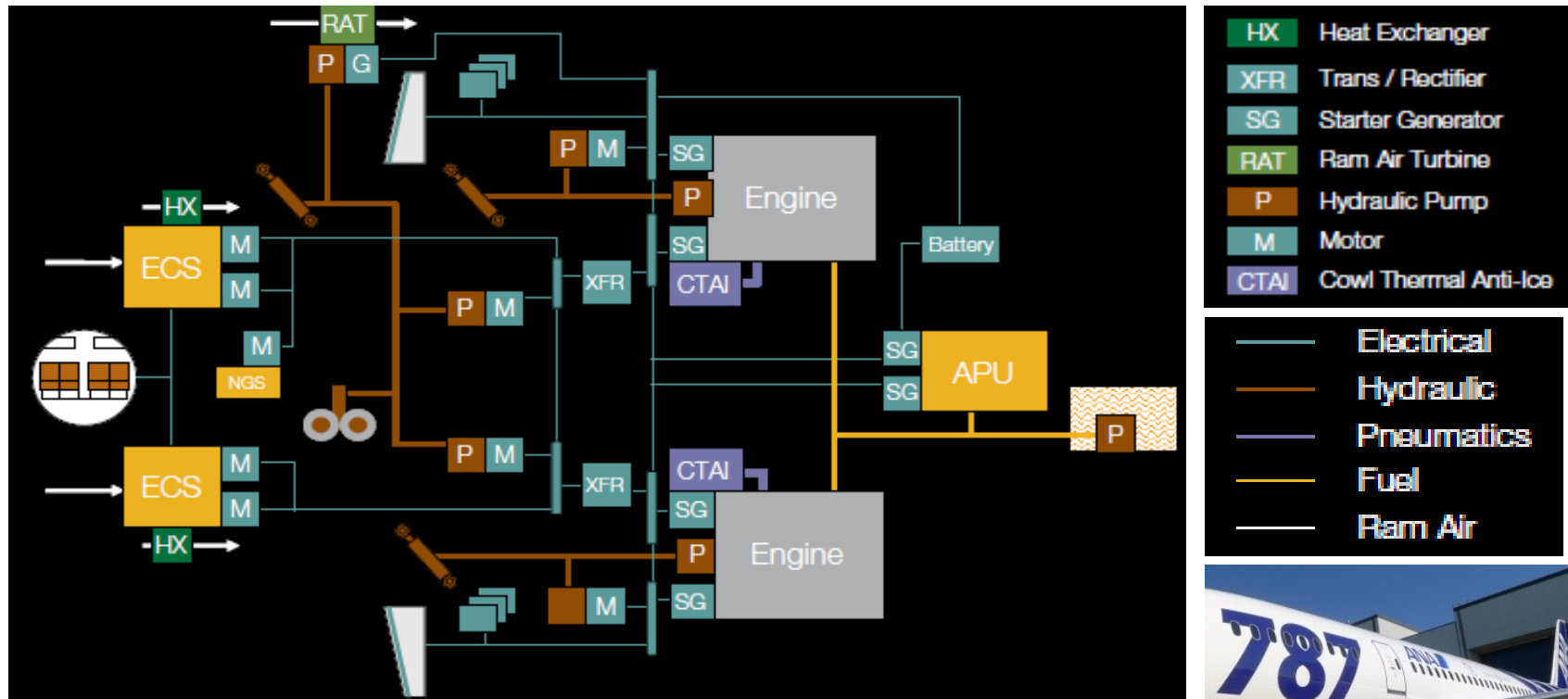

The "Pack" of the B787's Environmental Control System (ECS) is powered by electric motors (M) to compress ambient air up to cabin pressure and to push the air through the heat exchangers (HX) for cooling. The power for the electric motors is produced by generators (SG) connected to the aircraft's engine and APU. After compression and cooling the air is delivered to the cabin.



Solutions

More Electric A320?

Electrical innovations flightlab

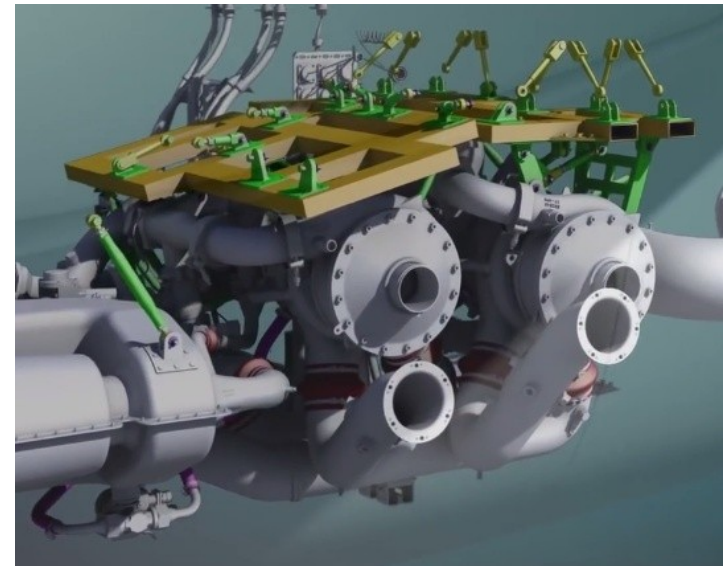
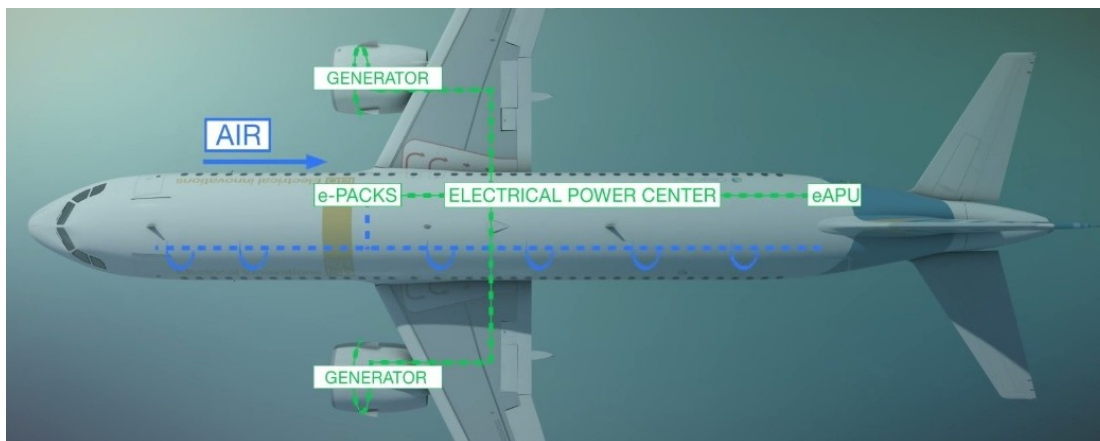

Solutions

More Electric A320 with Electrical (Bleed Free) Cabin Air Supply?

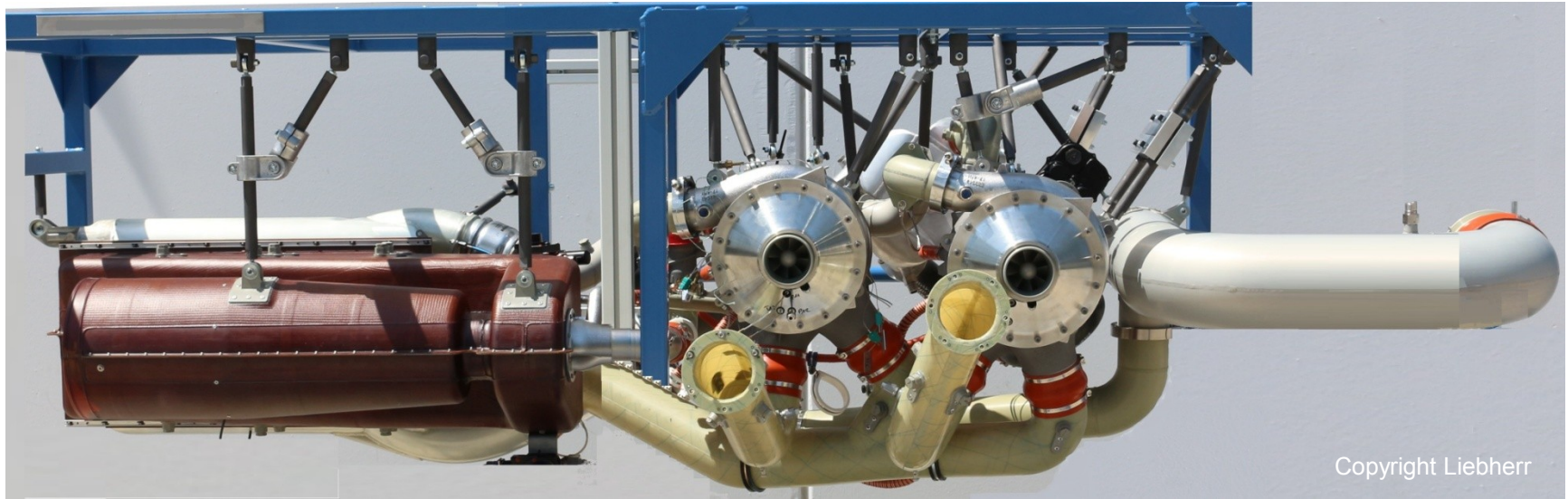

Copyright Liebherr

The Electrical Environmental Control System (E-ECS) was developed by Liebherr-Aerospace Toulouse SAS, Toulouse (France), Liebherr's center for air management systems. The E-ECS is equipped with a new type of motorized turbo compressor (50 kW) which enables to use directly external air (bleed less) for air conditioning. The power electronics ensure the speed control of the motorized turbo compressor and offer synergy capabilities with other electrical loads to optimize the overall electrical power consumption on board the aircraft. The interaction between air intake and the turbo-compressors and the performance of the system in all operating conditions was tested in a flight test campaign with Airbus A320-Prototyp MSN001 from June 3 to June 24, 2016. E-ECS will also contribute to fuel burn reduction.

(Liebherr 2016)



Aircraft Cabin Air and Engine Oil – A Systems Engineering View

Contact

info@ProfScholz.de

<http://www.ProfScholz.de>

<http://CabinAir.ProfScholz.de>

Aircraft Cabin Air and Engine Oil – A Systems Engineering View

References

A320 AMM

Airbus: A320 – Aircraft Maintenance Manual (AMM)

A320 FCOM

Airbus: A320 – Flight Crew Operating Manual (FCOM)

A320 GENFAM

Airbus: A320 – General Familiarization (GenFam)

A340 FCOM

Airbus: A340 – Flight Crew Operating Manual (FCOM)

A350 XWB News 2012

Blogjfa: *A350 XWB Cabin Air Quality will make a Comfortable Flight although -50 °C Outside*, A350 XWB News (Blog), 2012. – URL: <http://bloga350.blogspot.de/2012/11/a350-xwb-cabin-air-quality-will-make.html>

Abou-Donia 2013

Abou-Donia, Mohamed B.; Abou-Donia, Martha M.; El Masry, Eman M.; Monro, Jean A.; Mulder, Michel F. A.: Autoantibodies to Nervous System-Specific Proteins are Elevated in Sera of Flight Crew Members: Biomarkers for Nervous System Injury. In: *Journal of Toxicology and Environmental Health, Part A*, 76, pp. 363-380, 2013, <https://doi.org/10.1080/15287394.2013.765369>. – URL: http://www.aerotoxicteam.com/uploads/6/0/3/8/6038702/aerotoxic_abou-donia_autoanti-bodies_jteh_a-1.pdf

References

Aircraft Interiors 2017

Aircraft Interiors: *News: World's First Aircraft Cabin Monitor for Toxic Air Announced*, UKIP Media & Events, 2017. –
URL: <http://www.aircraftinteriorsinternational.com/news.php?NewsID=84385>

Airlineratings 2017

Airline Ratings, 2017. – URL: <http://image.airlineratings.com/articles/DC-8%20DWDcropfb.jpg>

Airliners 1999

Discussion on www.airliners.net, 1999. – URL: <http://www.airliners.net/forum/viewtopic.php?t=72326>

Airsense 2017

Airsense Analytics: *aerotracer - Supervision in Aviation Industry*, Leaflet, 2017. –
URL: http://www.airsense.com/sites/default/files/airsense_aerotracer.pdf

AOPA 2004

AOPA: *Mandatory Carbon Monoxide Detectors Would Have Little Effect on Safety CO Related Accidents with General Aviation (GA) Aircraft*, 2004. – URL: <https://www.aopa.org/news-and-media/all-news/2004/june/30/mandatory-carbon-monoxide-detectors-would-have-little-effect-on-safety>

Aviation Herald 2010

Aviation Herald: *Incident: US Airways B752 over Pacific on Sep 17th 2010, Smoke in Cockpit*, 2010. –
URL: <http://avherald.com/h?article=4311269d>

B737 AMM

Boeing: B737 – Aircraft Maintenance Manual (AMM)

References

BFU 2014

Bundesstelle für Flugunfalluntersuchung (BFU): *Study of Reported Occurrences in Conjunction with Cabin Air Quality in Transport Aircraft*, 2014 (BFU 803.1-14). –

URL: https://www.bfu-web.de/EN/Publications/Safety%20Study/Studies/140507_Fume_Events.pdf?__blob=publicationFile

Boeing 2007

Sinnett, Mike: 787 No-Bleed Systems: Saving Fuel and Enhancing Operational Efficiencies. In: Boeing: *AERO*, 2007, No. 4, Art. 2, pp. 6-11. – URL: http://www.boeing.com/commercial/aeromagazine/articles/qtr_4_07/article_02_1.html

Cannon 2016

Cannon, Frank: Aircraft cabin air contamination and aerotoxic syndrome – A review of the evidence. In: Collegium Basilea: *Nanotechnology Perceptions*, Vol. 12 (2016), pp. 73-99, <https://doi.org/10.4024/N08CA16A.ntp.12.02>. – Download: URL: <http://skybrary.aero/bookshelf/books/3594.pdf>

De Nola 2008

De Nola, G.; Kibby, J.; Mazurek, W.: Determination of Ortho-Cresyl Phosphate Isomers of Tricresyl Phosphate Used in Aircraft Turbine Engine Oils by Gas Chromatography and Mass Spectrometry. In: *Journal of Chromatography A*, Vol. 1200, No. 2, pp. 211-216, 25 July 2008, <https://doi.org/10.1016/j.chroma.2008.05.035>

DGLR 2014

Deutsche Gesellschaft für Luft- und Raumfahrt (DGLR): Pratt & Whitney setzt für Getriebefan-Antriebe auf Bürstendichtungen. In: *Luft- und Raumfahrt*, Special Issue: "A320neo – Special", 2014

EASA 2003

European Aviation Safety Agency (EASA): *European Technical Standard Orders*, contains ETSO C48: "Carbon Monoxide Detection Instruments", 2003. – URL: <https://www.easa.europa.eu/system/files/dfu/CS-ETSO.pdf>

References

EASA 2010

European Aviation Safety Agency (EASA): *Supplemental Type Certificate 10030229 (B757)*, 2010. –
URL: <http://bleedfree.eu/wp-content/uploads/2015/10/B757-air-filter-EASA-STC.pdf>

EASA 2017a

European Aviation Safety Agency (EASA): *CAQ – Preliminary Cabin Air Quality Measurement Campaign*, 2017. –
URL: <https://www.easa.europa.eu/document-library/research-projects/easarepresea20144>,
Project partners: Fraunhofer ITEM, Hannover Medical School (MHH), Lufthansa Technik AG / Deutsche Lufthansa AG, Condor Flugdienst GmbH, British Airways

EASA 2017b

European Aviation Safety Agency (EASA): *AVOIL – Characterisation of the Toxicity of Aviation Turbine Engine Oils after Pyrolysis*, 2017. –
URL: <https://www.easa.europa.eu/document-library/research-projects/easarepresea20152>,
Project partners: The Netherlands Organization for Applied Scientific Research (TNO), National Institute for Public Health and the Environment (RIVM), Institute for Environmental Studies (IVM), Institute for Risk Assessment Sciences (IRAS)

EASA CS-23

European Aviation Safety Agency (EASA): *Certification Specification (CS-23) "Normal, Utility, Aerobatic and Commuter Aeroplanes"*, 2012. –
URL: <https://www.easa.europa.eu/certification-specifications/cs-23-normal-utility-aerobatic-and-commuter-aeroplanes>

EASA CS-25

European Aviation Safety Agency (EASA): *Certification Specification (CS-25) "Large Aeroplanes"*, 2017. –
URL: <https://www.easa.europa.eu/certification-specifications/cs-25-large-aeroplanes>

References

Eckels 2014

Eckels, Steven J.; Jones, Byron; Mann, Garrett; et al.: Aircraft Recirculation Filter for Air-Quality and Incident Assessment. In: *Journal of Aircraft*, Vol. 51, No. 1, pp. 320-326, 2014, <https://doi.org/10.2514/1.C032458>

EPA 2017

U.S. Environmental Protection Agency (EPA): *Introduction to Indoor Air Quality*. – URL: <https://www.epa.gov/indoor-air-quality-iaq/introduction-indoor-air-quality>

Eurofins 2017

Eurofins Scientific (eurofins): *What does VOC mean?*. – URL: <http://www.eurofins.com/voc.aspx>

Exxon 2016a

EXXON: *Jet engine oil system, part 1*, 2016. – <https://www.exxonmobil.com/en/aviation/knowledge-library/resources/jet-engine-oil-system-1>

Exxon 2016b

EXXON: *Jet engine oil system, part 2*, 2016. – <https://www.exxonmobil.com/en/aviation/knowledge-library/resources/jet-engine-oil-system-2>

Exxon 2016c

EXXON: *Material Safety Data Sheet (MSDS): Mobile Jet Oil II*, 2016. – <http://www.msds.exxonmobil.com/IntApps/psims/Download.aspx?ID=743589>

FAA 2009a

Hossein, S.; Cheraghi, Michael; Jorgensen, J.; Myose, Roy Y.: *Detection and Prevention of Carbon Monoxide Exposure in General Aviation Aircraft*, Federal Aviation Administration (DOT/FAA/AR-09/49), 2009. – URL: <http://www.tc.faa.gov/its/worldpac/techrpt/ar0949.pdf>

References

FAA 2009b

Federal Aviation Administration (FAA): *TSO C48a – Carbon Monoxide Detector Instruments*, 2009. – URL: [http://rgl.faa.gov/Regulatory_and_Guidance_Library/rgTSO.nsf/0/e0a29b3d3495a3b2862575af00640c32/\\$FILE/TSO_C48a.pdf](http://rgl.faa.gov/Regulatory_and_Guidance_Library/rgTSO.nsf/0/e0a29b3d3495a3b2862575af00640c32/$FILE/TSO_C48a.pdf)

FAA 2017

Federal Aviation Administration (FAA): *Technical Standard Order (TSO)*, 2017. – URL: https://www.faa.gov/aircraft/air_cert/design_approvals/tso

Flight International 2014

Learmount, David: Cabin air killed BA pilot, say experts. In: *Flight International*, 5-11 August 2014

Flight International 2017

Learmount, David: ANALYSIS: Airlines urged to restore 'blind flying' skills. In: *Flight-Global*, 23 March 2017. – URL: <https://www.flightglobal.com/news/articles/analysis-airlines-urged-to-restore-blind-flying-s-435094>

GCAQE 2017

Global Cabin Air Quality Executive (GCAQE): *Contaminated Air Overview*, 2017. – URL: <https://gcaqe.org/wp-content/uploads/2017/03/GCAQE-CAQ-Brochure-Public-2017.pdf>

Henschler 1958

Henschler, Dietrich: Die Trikresylphosphat Vergiftung - Experimentelle Klärung von Problemen der Ätiologie und Pathogenese. In: *Klinische Wochenschrift*, Vol. 36, No. 14, 15 July 1958, pp. 663-674. – URL: http://www.anstageslicht.de/fileadmin/user_upload/Geschichten/Aerotoxisches_Syndrom/25_Henschler_D_Trikresylphosphatvergiftung_red.pdf

Hingtgen 2004

Hingtgen, David: *Ultimate Boeing 707 Guide*, 2004. – URL: <http://www.airlinercafe.com/page.php?id=72>

References

House of Lords 2007

House of Lords, Science and Technology Committee: *Air Travel and Health: an Update - Report with Evidence*, 2007. – URL: <https://publications.parliament.uk/pa/ld200708/ldselect/ldsctech/7/7.pdf>

Imbert 1997

Imbert, F.E.; Gnep, N.; Guisnet, M.: Cresol isomerization on HZSM-5. In: *Journal of Catalysis*, Vol. 172, No. 2, pp. 307-313, December 1997, <https://doi.org/10.1006/jcat.1997.1884>

Jetpilot 2001

Jetpilot: Answer to "What are the 'Air Intakes' on the nose of some aircraft?", 2001. – URL: <http://www.airliners.net/forum/viewtopic.php?t=725419#p10518793>

Lamb 2012

Lamb, Judith; McGonagle, Carolyn; Cowie, Hilary; Cherrie, John W.: *Cabin Air – surface residue study*, Research Report TM/11/06, March 2012, Institute of Occupational Medicine, UK – URL: http://www.iom-world.org/pubs/iom_tm1106.pdf

Liebherr 2016

Liebherr: *Electrical Environmental Control System of Liebherr Successful during First Flight of Clean Sky/Airbus Flight Lab*, Press Release, 2016-07-15. – URL: <https://www.liebherr.com/en/aus/latest-news/news-press-releases/detail/electrical-environmental-control-system-of-liebherr-successful-during-first-flight-of-clean-sky-airbus-flight-lab.html>

Lufthansa 2017

Lufthansa, Cabin Air Quality Team: *Cabin Air Quality Crew Info*, No. 1 (February 2017), Lufthansa Group, 2017. – URL: http://www.anstageslicht.de/fileadmin/user_upload/Geschichten/Aerotoxisches_Syndrom/LH_Februar17_Cabin_Air_Quality_Crew_Info.pdf

References

Michaelis 2010

Michaelis, Susan: *Health and flight safety implications from exposure to contaminated air in aircraft*, PhD Thesis, Safety Science, Faculty of Science, University of New South Wales, Sydney, Australia, 2010. – URL: <http://handle.unsw.edu.au/1959.4/50342>

Michaelis 2012

Michaelis, Susan: *Aircraft Cabin Air Contamination - Health & Flight Safety Implications*, Lecture at Hamburg University of Applied Sciences, 2012-11-08, DGLR / RAeS / VDI, Lecture Notes, 2012. – URL: <http://hamburg.dglr.de> (Vorträge 2. Halbjahr 2012)

Michaelis 2016a

Michaelis, Susan: *Implementation of the Requirements for the Provision of Clean Air in Crew and Passenger Compartments Using the Aircraft Bleed Air System*, Master Thesis, Cranfield University, 2016. – URL: http://www.susanmichaelis.com/pdf/2016_Susan Michaelis_MSc Cranfield-Clean air requirements using bleed air system.pdf

Michaelis 2016b

Michaelis, Susan: Oil bearing seals and aircraft cabin air contamination. In: *Sealing Technology*, 2016, No. 4, pp. 7-10, [https://doi.org/10.1016/S1350-4789\(16\)30104-0](https://doi.org/10.1016/S1350-4789(16)30104-0)

NRC 2002

National Research Council: *The Airliner Cabin Environment and the Health of Passengers and Crew*, 2002. – Committee on Air Quality in Passenger Cabins of Commercial Aircraft, Board on Environmental Studies and Toxicology. ISBN: 0-309-56770-X. Download from: National Academies Press, URL: <http://www.nap.edu/catalog/10238.html>

References

NTSB 2004

National Transportation Safety Board (NTSB): *Safety Recommendation* (Installation of CO detectors), 2004. – URL: https://www.ntsb.gov/safety/safety-recs/recletters/A04_25_28.pdf

OHRCA 2014

Steven Hecker; et al.: *Cabin Air Quality Incidents Project Report*, Occupational Health Research Consortium in Aviation (OHRCA), 2014. – URL: <http://www.ohrca.org/wp-content/uploads/2014/08/finalreport.pdf>

Pall 2011

Pall: *Odour/VOC Removal Filters – Frequently Asked Questions*, 2011. – URL: <http://www.pall.de/pdfs/Aerospace-Defense-Marine/AEOVOCEN.pdf>

Pall 2016

Pall: *Pall Aerospace Announces EasyJet Adoption of PUREair Advanced Cabin Air Filters*, Press Release, 2016. – URL: <https://aerospace.pall.com/en/press-release/pall-aerospace-announces-easyjet.html>, picture of recirculation filter: <https://goo.gl/images/s8Bz1s>

Petro-Canada 2017

Petro-Canada: *SAFETY DATA SHEET TURBONYCOIL 600*, 2017. – URL: <https://lubricants.petro-canada.com/Api/sitecore/LubesApi/DownloadResource?docID=TN600&type=MSDS&lang=en-US>

Pohanish 2012

Pohanish, Richard P.: *Sittig's Handbook of Toxic and Hazardous Chemicals and Carcinogens*, William Andrew (Elsevier), 2012. – URL: <https://static.compliancetrainingonline.com/docs/Sittigs-Handbook-of-Toxic-and-Hazardous-Chemicals-and-Carcinogens-2012.pdf>

References

Ramsden 2013a

Ramsden, Jeremy J.: On the proportion of ortho isomers in the tricresyl phosphates contained in jet oil. In: Collegium Basilea & AMSI: *Journal of Biological Physics and Chemistry*, Vol. 13(2013), pp. 69-72, <https://doi.org/10.4024/03RA13L.jbpc.13.02>, <http://www.amsi.ge/jbpc/index.html>. – Download from URL: <https://www.researchgate.net/publication/260032954>

Ramsden 2013b

Ramsden, Jeremy J.: Jet engine oil consumption as a surrogate for measuring chemical contamination in aircraft cabin air. In: Collegium Basilea & AMSI: *Journal of Biological Physics and Chemistry*, Vol. 13 (2013), pp. 114-118. – <https://doi.org/10.4024/11RA13L.jbpc.13.04>, <http://www.amsi.ge/jbpc/index.html>. – Download from URL: <http://www.oprus2001.co.uk/11RA13L.pdf>

Reiss 2016

Reis, Christian: *Neues Kabinenluftmesssystem - Gröger und Obst stellt sich vor*, VC-Info 2016, No. 3, p. 37, 2016. – URL: <http://groegerobst.de/wp-content/uploads/2017/10/Neues-zu-Kabinenluftmesssystemen-VOC.pdf>

Rolls Royce 2015

Rolls Royce: *The Jet Engine*, 2015. – ISBN: 978-1-119-06599-9

SAE ARP 85

Standard SAE ARP 85, *Air Conditioning Systems for Subsonic Airplanes*, 2012 (first edition 1943) (no DOI available). – URL: <https://www.sae.org/standards/content/arp85>, <https://saemobilus.sae.org/content/ARP85>, <https://saemobilus.sae.org/content/ARP85A>, ... <https://saemobilus.sae.org/content/ARP85F>

References

SAE ARP 1796

Standard SAE ARP 1796, *Engine Bleed Air Systems for Aircraft*, 2015 (first edition 1987, A in 2007, B in 2015),
<https://doi.org/10.4271/ARP1796>. – URL:
<https://saemobilus.sae.org/content/ARP1796>,
<https://saemobilus.sae.org/content/ARP1796A>,
<https://saemobilus.sae.org/content/ARP1796B>

SAE ARP 1796

Standard SAE ARP 1796, *Engine Bleed Air Systems for Aircraft*, 2015 (first edition 1987, A in 2007, B in 2015),
<https://doi.org/10.4271/ARP1796>. – URL:
<https://saemobilus.sae.org/content/ARP1796>,
<https://saemobilus.sae.org/content/ARP1796A>,
<https://saemobilus.sae.org/content/ARP1796B>

SAE AIR 1168-7

Standard SAE AIR 1168-7, *Aerospace Pressurization System Design*, 2011 (first edition 1991, A in 2011),
<https://doi.org/10.4271/AIR1168/7>. – URL:
<https://saemobilus.sae.org/content/AIR1168/7>,
<https://saemobilus.sae.org/content/AIR1168/7A>

SAE AIR 1116

Standard SAE AIR 1116, *Fluid Properties*, 2013 (first edition 1969, A in 1999, B in 2013) (no DOI available). – URL:
<https://www.sae.org/standards/content/air1116>
<https://saemobilus.sae.org/content/AIR1116>,
<https://saemobilus.sae.org/content/AIR1116A>
<https://saemobilus.sae.org/content/AIR1116B>

References

SAE AS-412

Standard SAE AS-412, *Carbon Monoxide Detector Instruments*, 2008 (first edition 1948, A in 1956, B in 2008) (no DOI available). – URL:

<https://saemobilus.sae.org/content/AS412>

<https://saemobilus.sae.org/content/AS412A>

<https://saemobilus.sae.org/content/AS412B>

Solbu 2011

Solbu, Kasper; Daae, Hanne Line; Olsen, Raymond; et al.: Organophosphates in aircraft cabin and cockpit air – method development and measurements of contaminants. In: *Journal of Dynamic Environmental Monitoring*, Vol. 13 (2011), No. 5, pp. 1393-1403, <https://doi.org/10.1039/c0em00763c>

Telegraph 2017

The Telegraph: *Family of 'poisoned' British Airways co-pilot claim aviation industry is ignoring issue of toxic cabin air*, 13 April 2017. – URL:

<http://www.telegraph.co.uk/news/2017/04/13/family-poisoned-british-airways-co-pilot-claim-aviation-industry>

van Beveren 2011

van Beveren, Tim: *Stellungnahme zum Thema 'kontaminierte Kabinenluft' - Anhörung vor dem Ausschuss für Tourismus des Deutschen Bundestages* (includes: interview with Prof. Abou-Donia), 2011. – URL:

http://www.timvanbeveren.de/wp-content/uploads/2012/06/van-Beveren_Stellungnahme_Kabinenluft_21092011pubr.pdf

Van Netten 2008

Van Netten, Chris: Design of a small personal air monitor and its application in aircraft. In: *Science of The Total Environment*, Vol. 407, No. 3, 15 January 2009, pp. 1206-1210, <https://doi.org/10.1016/j.scitotenv.2008.07.067>

References

Wikipedia 2017a

Aainsqatsi, K.: Schematic diagram illustrating the operation of a low-bypass turbofan engine, 2008. – URL:
https://commons.wikimedia.org/wiki/File:Turbofan_operation_lbp.svg;
<https://creativecommons.org/licenses/by-sa/3.0>

Wikipedia 2017b

Galloway, Martin J.: Boeing 707 Engine View, 2011. – URL:
https://commons.wikimedia.org/wiki/File:Boeing_707_engineviewedit.jpg
<https://creativecommons.org/licenses/by-sa/3.0>

Winder 2001

Winder, Chris; Balouet, Jean-Christophe: The Toxicity of Commercial Jet Oils. In: *Environmental Research*, Vol. 89, No. 2 (June 2002), pp. 146-164, <https://doi.org/10.1006/enrs.2002.4346>. – URL:
<http://jet-oil.com/The%20Toxicity%20of%20commercial%20Jet%20Oils.pdf>

All online resources have been accessed on 2018-02-18 or later.

Quote this document:

Scholz, Dieter: *Aircraft Cabin Air and Engine Oil – A Systems Engineering View*, Hamburg Aerospace Lecture Series (HALS), DGLR / RAeS / VDI / ZAL / HAW Hamburg / VC / UFO, HAW Hamburg, 27 April 2017,
<https://doi.org/10.5281/zenodo.1237858>

This document is also available on
<http://CabinAir.ProfScholz.de>
<http://hamburg.dglr.de> => Vorträge 1. Halbjahr 2017