

# A Comparative Study on Fuzzy and Neuro-Fuzzy Enabled Cluster Based Routing Protocols for Wireless Sensor Networks

Y. Harold Robinson, E. Golden Julie

**Abstract**—Dynamic Routing in Wireless Sensor Networks (WSNs) has played a significant task in research for the recent years. Energy consumption and data delivery in time are the major parameters with the usage of sensor nodes that are significant criteria for these networks. The location of sensor nodes must not be prearranged. Clustering in WSN is a key methodology which is used to enlarge the life-time of a sensor network. It consists of numerous real-time applications. The features of WSNs are minimized the consumption of energy. Soft computing techniques can be included to accomplish improved performance. This paper surveys the modern trends in routing enclose fuzzy logic and Neuro-fuzzy logic based on the clustering techniques and implements a comparative study of the numerous related methodologies.

**Keywords**—Wireless sensor networks, clustering, fuzzy logic, neuro-fuzzy logic, energy efficiency.

## I. INTRODUCTION

IN WSNs, routing consists of both heterogeneous and homogeneous systems with a huge number of tiny devices called sensor node. Each device will have the responsibility of sensing, computation and secure communication [1], [85]. Devices are cooperating to each other and the sensor will autonomously sense the data. Two components are used in the wireless network aggregation; point and base station [3]. Further, nodes have rigorously limited computation, storage and power capabilities. However, they will tolerate numerous challenges [6]. The position of sensor nodes cannot be pre-determined because they are deployed randomly. The sensors are battery driven and deployed in unmanned environments, requiring energy conservation. The sensors are mostly mobile [2]. Static routing algorithms fail in WSNs. Random deployment may result in holes which are regions without enough working sensors. Clustering is one of the techniques to extend the network lifetime. In a clustering protocol, the geologically neighboring nodes are gathered into virtual groups called “clusters” [9], [65].

Each cluster has one Cluster Head (CH) and other nodes are called cluster nodes. Instead of direct communication with the destination, all the cluster nodes send data to the CH [88]. Clustering algorithms can be based on some criteria like

Harold Robinson Y. is an Associate Professor with the Department of Computer Science and Engineering, SCAD College of Engineering and Technology, India (e-mail: yhrobinphd@gmail.com).

Golden Julie is an Assistant Professor, Department of Computer Science and Engineering, Anna University, Chennai, India (e-mail: goldenjuliephd@gmail.com).

battery nodes power, mobility, network size, speed, distance and direction [4], [5].

Low Energy Adaptive Clustering Hierarchy (LEACH) is one of the most well-known energy efficient clustering algorithms for WSNs [7], [66]. The operation of LEACH has two stages; setup phase and steady phase. To minimize the packet overhead, the steady-state segment considers data aggregation [12] for secure transmission. Besides LEACH, various clustering algorithms have been proposed for homogeneous WSNs [8], [86]. Fig. 1 illustrates the architecture for the WSNs.

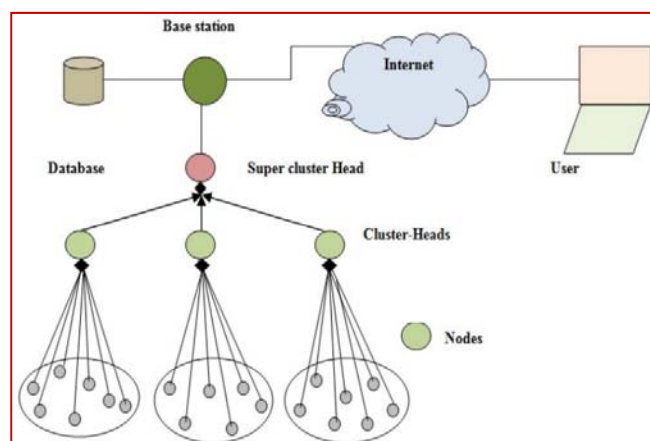

Fig. 1 Architecture of WSNs

## II. ROUTING PROTOCOLS

Routing is the process of forwarding data from source to destination. Routing occurs in network layer. Routing involves two activities. One is identifying the path for forwarding the data; second is transferring the packet without error [10], [11], [87]. A lot of attributes to the sink will select the best path for transfer the packet using packet control messages [15], [76]. Subsequently, transferring packet from the source to the destination also hold various attributes for forwarding data successfully. Each packet should deliver the data without any error or security issues to the destination for finding optimal path [18], [77].

The delivered packet uses some standard metric to evaluate the correct and efficient path [89]. They are, Flat network routing, Hierarchical routing, and Location based routing as shown in Fig. 2.

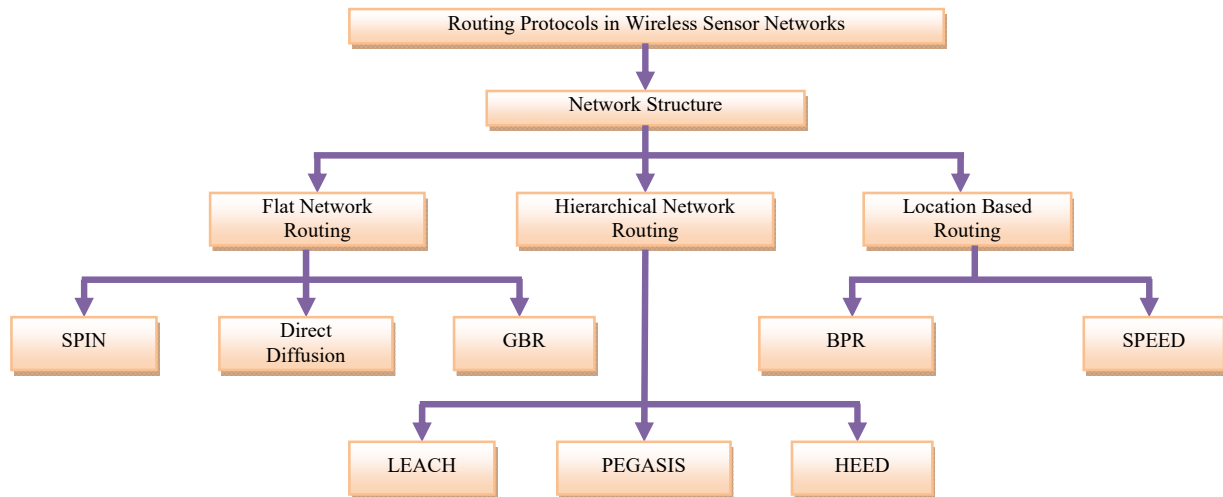

Fig. 2 Taxonomy of routing protocol in WSN

### A. Flat Network Routing

Flat network routing consists of larger number of nodes in a network. Due to larger network size the node will not have general identifier. Some of the Flat network routing algorithms are SPIN [40], Directed diffusion [41], GBR [43].

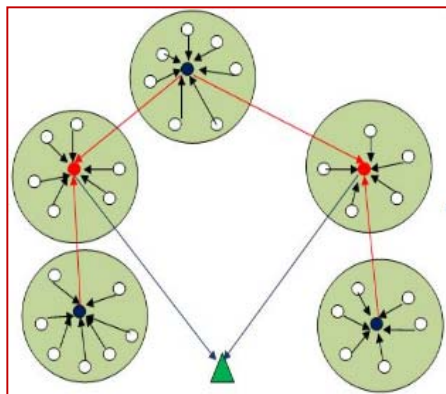

Fig. 3 Cluster Formation in WSN

### B. Hierarchical Network Routing

Hierarchical routing or cluster based routing is a layer routing protocol. It utilizes energy in an efficient manner, it improves overall system scalability. It consists of two layers in formal model, in which one layer is responsible for selecting the CH and the other layer is responsible for routing. This is used for lower energy consumption. Examples are LEACH [46], HEED [44].

### C. Location Based Routing

In location based routing, sensor nodes are addressed by means of their location, the location may be available from GPS. Sensor node consists of small GPS receiver for communicate [67]. It is equipped with scheduling the node for sleep (ideal) to improve energy. Node distances are calculated by their signal strength. Example: GRF [42].

## III. CLUSTER BASED ROUTING PROTOCOL

Traditional routing protocols for WSN are used for energy efficiency and load balancing. Clustering is used for energy efficiency and reducing overhead [25], [28].

### A. LEACH

LEACH has two phases. The first one is setup phase and the other is steady state phase. In the setup phase, LEACH selects randomly some nodes as a CH without any predetermined fraction of nodes. The threshold  $T(n)$  is computed based on an equation that integrates the valuable percentage to suit a CH, the set of nodes, and the current nodes that have not been selected as a CH in the last  $(1/P)$  rounds, it is denoted by  $G$ . It is given by,

$$T(n) = \frac{p}{1-p(r \bmod (1/p))} \text{ if } n \in G \quad (1)$$

where,  $G$  is the set of nodes that are involved in the CH election [26], [29]. During the steady phase, each CH collects the sensed data from the member node and aggregates them [90].

### B. PEGASIS

The enhancement of LEACH protocol is called as Power Efficient Gathering in Sensor Information System (PEGASIS). It consists of chain based clusters. All the nodes can communicate with its neighbor nodes in the chain. The chain construction is based on greedy fashion. Other nodes in the chain start receiving data and send the data to its next neighbor after aggregating the data. Sink node will receive data from the leader. Multi-hop routing is done in PEGASIS. There is delay in the chain for the nodes which are far away from the leader node [32].

### C. Threshold Sensitive Energy-Efficient Sensor Network Protocol (TEEN)

TEEN protocol is used for time critical applications. It uses a data centric mechanism [63]. Sensor node senses the medium continuously. The minimum possible value of an

attribute is known as hard threshold. Message transmission consumes less energy. This process will remove burden from the CH [34].

*D. Geographic Adaptive Fidelity (GAF)*

GAF [22] has three states; (i) detection, (ii) active and (iii) sleeping. Every node starts with the detection state [35].

TABLE I  
 CLUSTER ROUTING PROTOCOLS IN WSNs

Protocol Name	Cluster Stability	Delivery Delay	Scalability	Algorithm Complexity	Energy Efficiency
LEACH	Medium	Very Small	Very Low	Low	Very Poor
HEED	High	Medium	Medium	Medium	Medium
PEGASIS	Low	Very Large	Very Low	High	Poor
TEEN	High	Small	Low	High	Very High
GAF	Medium	Poor	High	Medium	Medium

IV. SOFT COMPUTING TECHNIQUES

Soft computing could be a branch of engineering that has its inspiration from nature. In control system engineering, formal logic primarily based controller provides higher performance than standard controllers. Recently, several fuzzy based clustering algorithms [21], [10] have been proposed which ensure lower energy consumption.

*A. Fuzzy Logic*

A fuzzy inference system is based on fuzzy set theory for computing framework. The basic structure of fuzzy rule base system consists of three parts [60], [69]. They are rule based, database and reasoning mechanism [57], [70]. Fig. 2 illustrates the procedure.

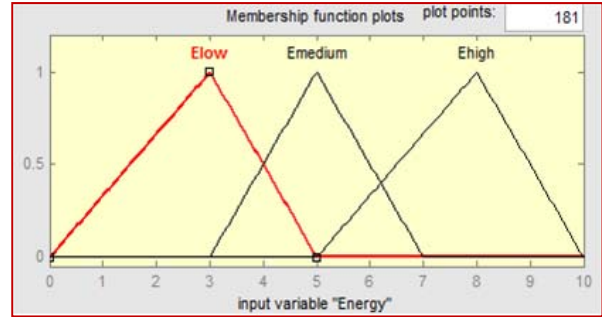

Fig. 6 Membership function for Energy

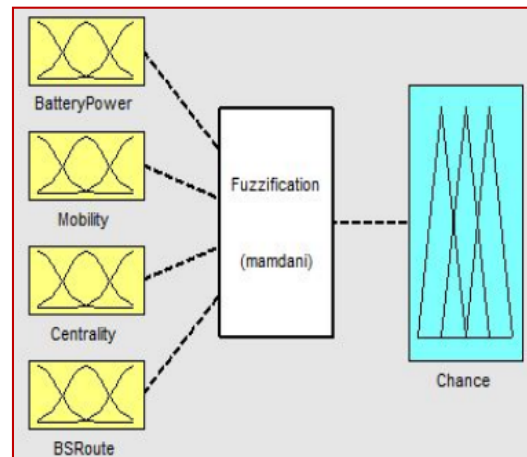

Fig. 7 Membership function for Fuzzification using Mamdani

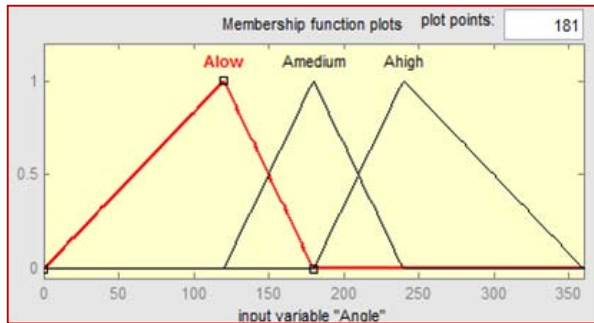

Fig. 4 Membership function for Angle

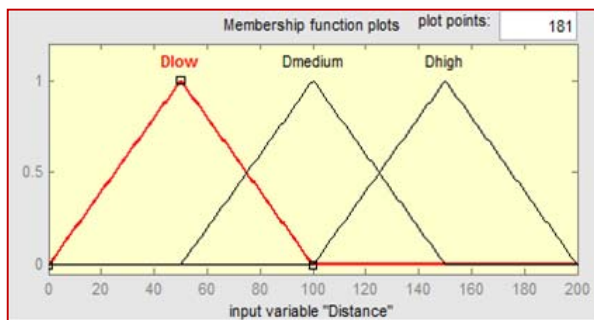

Fig. 5 Membership function for Distance

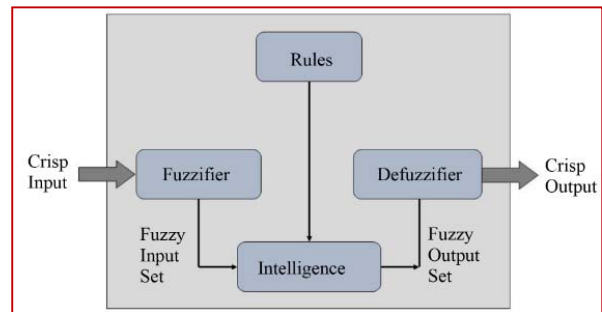

Fig. 8 Architecture for Fuzzy Logic

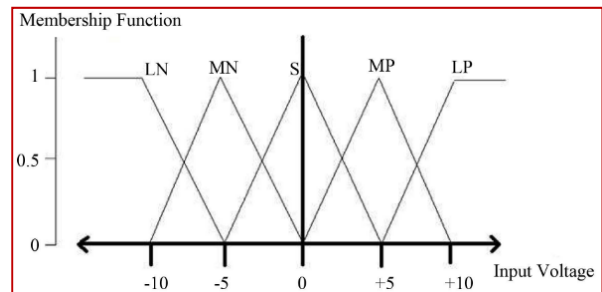

Fig. 9 Membership Function

Fuzzy logic consists of a decision making approach which works similarly to human control logic, which provides a simple method to reach a conclusion from imprecise, vague, or ambiguous input information [13], [17], [71]. The

execution of a fuzzy logic system will reduce the computation problem compared to the conventional mathematical methods [14], [19].

The fuzzy rules and fuzzy reasoning are the backbone of

fuzzy inference system [23]. It consists of a series of IF-THEN rules that relate the input fuzzy variables with the output fuzzy variables using linguistic variables (modeling human thinking) [16], [20].

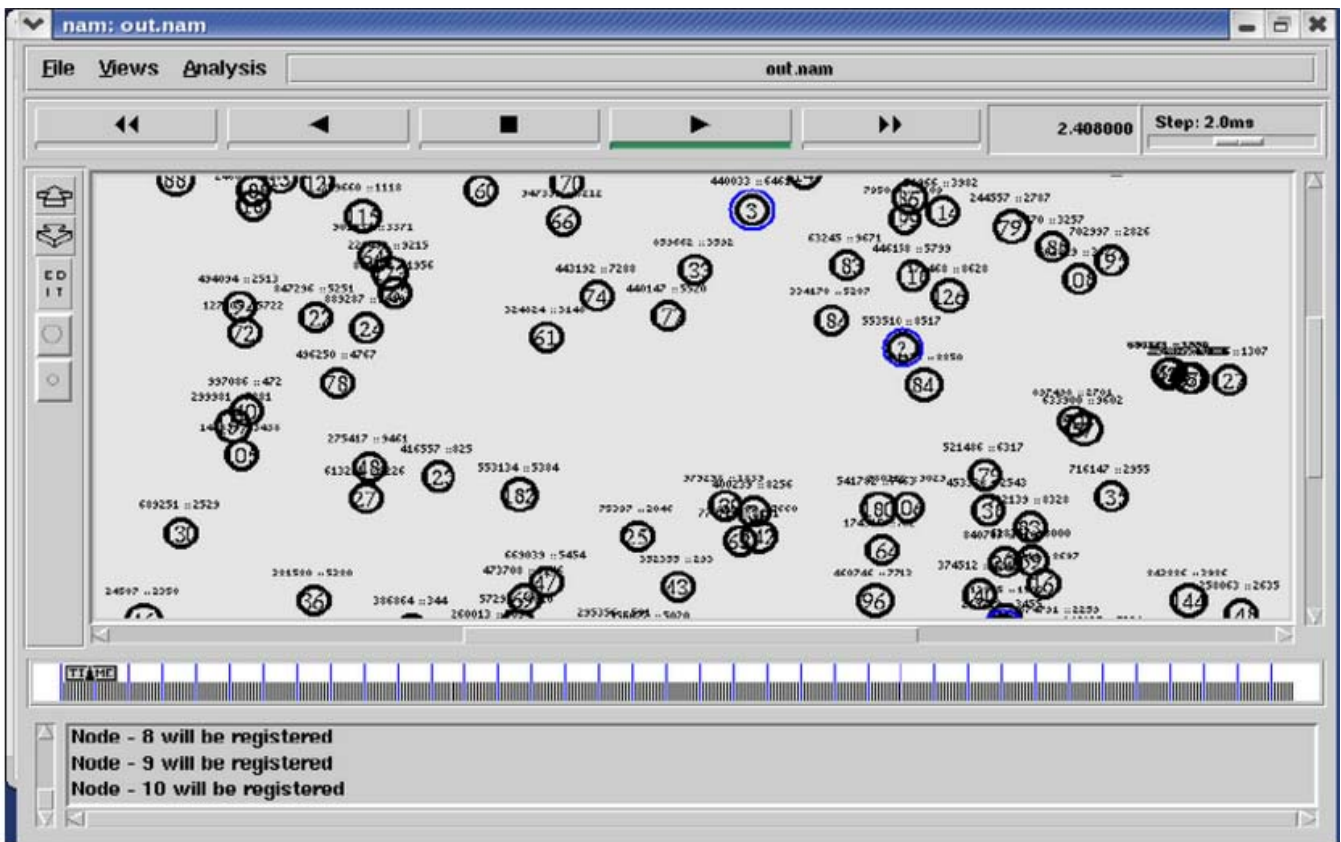

Fig. 10 Output File

### V. CLUSTER BASED PROTOCOL USING FUZZY LOGIC

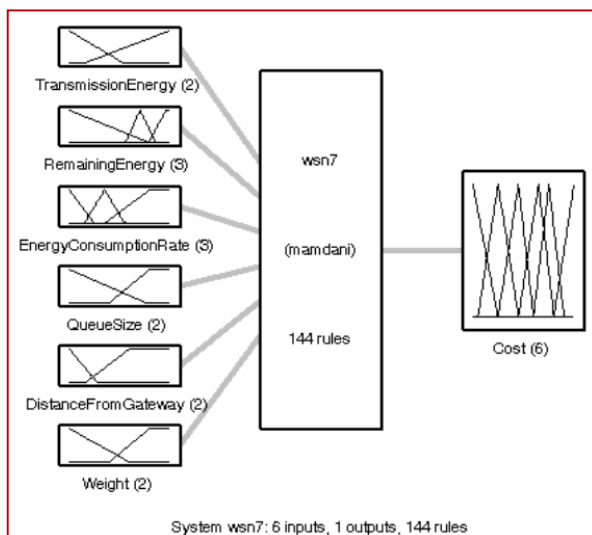

Fig. 11 Fuzzy System Model

In general, fuzzy logic is a multi valued logic, by which intermediate values can be defined using expressions such

as true/false, high/low, below/above, etc. [37], [72], [73]. The most common fuzzy logic inferences are the Mamdani and Tsukamoto-Sugeno methods [38].

The input of a Mamdani fuzzy logic system is usually a crisp value. Mamdani uses the centroid technique which tries to determine the point where a vertical line divides the combined set into two equal parts [24]. Fig. 5 displays our fuzzy model.

### VI. CH SELECTION BASED PROTOCOL USING FUZZY LOGIC

In Cluster Head Election using Fuzzy (CHEF) logic approach [47], the CH selection is based on two parameters: One is energy remain of the node (initial all nodes having same energy), second parameter is local distance (it is based on the signal receiving strength) and output parameter is chance (tentative CH) using fuzzy if then rule. CH election is based on fuzzy rule among all sensor nodes in the network. By using fuzzy logic, the computational overhead is reduced and prolongs the network lifetime [75].

#### A. Fuzzy Multi Constraint Routing

The fuzzy multi constraint routing protocol [59] consists of many constraints like collision, traffic level, buffer

occupancy, battery power etc. Only one constraint is not enough for selecting CH.

as shown in Table V. A simulation result shows better improvement in the network life time.

TABLE II  
 RULE-BASE FUZZY INFERENCE SYSTEM

RULE NO.	INPUT PARAMETERS			OUTPUT
	ANGLE	DISTANCE	ENERGY	CHANCE
1	Low	Low	Low	Medium
2	Low	Low	Medium	Medium
3	Low	Low	High	High
4	Low	Medium	Low	Low
5	Low	Medium	Medium	Medium
6	Low	Medium	High	Medium
7	Low	High	Low	Low
8	Low	High	Medium	Low
9	Low	High	High	Medium
10	Medium	Low	Low	Low
11	Medium	Low	Medium	Medium
12	Medium	Low	High	Medium
13	Medium	Medium	Low	Low
14	Medium	Medium	Medium	Medium
15	Medium	Medium	High	Low
16	Medium	High	Low	Low
17	Medium	High	Medium	Low
18	Medium	High	High	Medium
19	High	Low	Low	Low
20	High	Low	Medium	Low
21	High	Low	High	Low
22	High	Medium	Low	Low
23	High	Medium	Medium	Medium
24	High	Medium	High	Low
25	High	High	hLow	Low
26	High	High	Medium	Low
27	High	High	High	Medium

**B. Improved Fuzzy Unequal Clustering**

Improved fuzzy unequal clustering [58] approach contains three parameters, energy, distance and density, as input variables and output variables are chance and radius

**C. FRCA**

Fuzzy Relevance-Based CH selection algorithm [61] is developed for wireless mobile ad-hoc sensor networks. It consists of three parameters Energy, Mobility, and Distance. Based on the degree, the node will select tentative CH. It reduces overhead due to flat structure by easy resource management and bandwidth allocation, efficient management of node positions and energy. FRCA improve routing performance.

**D. Fuzzy C Means Algorithm (FCM)**

It is a centralized clustering algorithm [50]. It uses the highest residual energy and the location information of nodes for selecting CHs. In this one, every point has a degree of belonging to some clusters rather than specifically belonging to single cluster [54]. The fuzzy logic principle is used for computing the degree of belonging to each cluster. This algorithm minimizes the inter-cluster distance. It is a very important tool used for image processing systems. There is better formation of clusters when compared to other approaches because the mean distance of each node to CH is minimized which optimizes the transmission power of non-CH nodes [74]. Fuzzy C-means approach is more useful to distribute the nodes among the clusters and to distribute the loads of the networks [51].

**E. Energy-Efficient CH Selection**

The energy-efficient cluster head selection (NECHS) mechanism is using fuzzy logic [56]. Table VI demonstrates Rule-Base Fuzzy Inference System for Energy-Efficient CH selection. For defuzzification, centre of gravity method has been used [48].

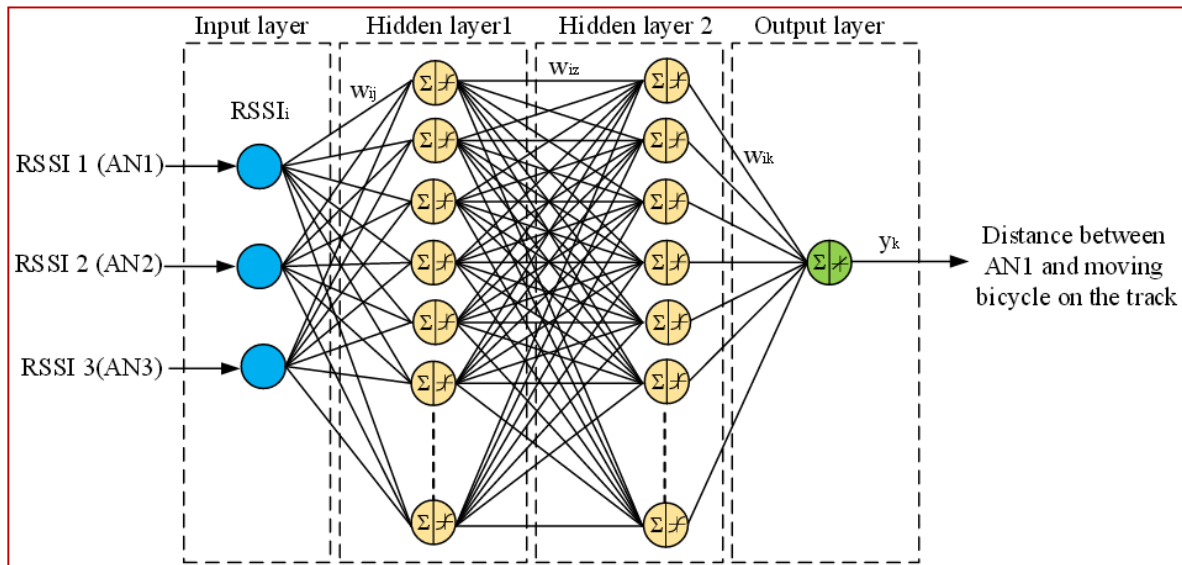

Fig. 12 Artificial Neural Network Model

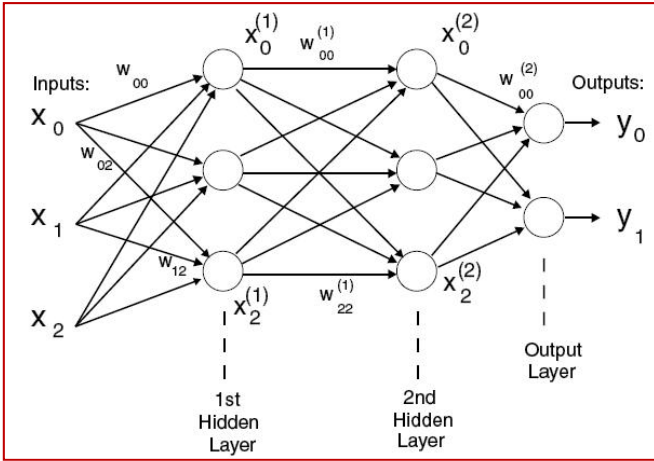

Fig. 13 Feed Forward Neural Network Model

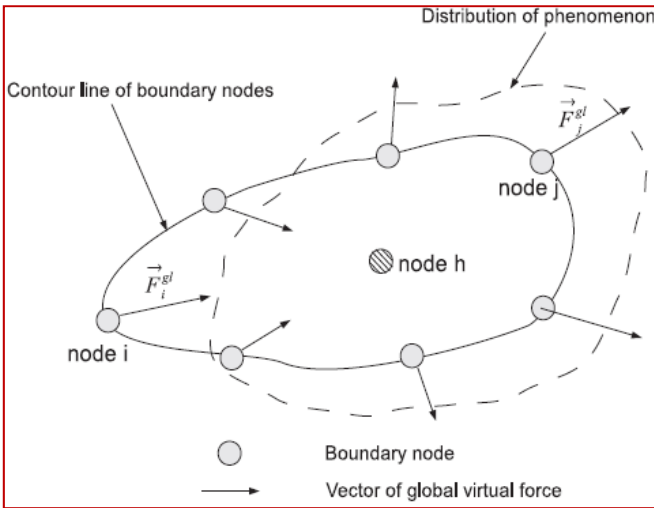

Fig. 14 Routing Model

**F. Fuzzy Self Clustering Algorithm (FSCA)**

It improves the performance of ACE [52] (an emergent algorithm for highly uniform cluster formation), clustering technique by fuzzy logic based system in each node. FSCA [36] ensures to become a CH by specifying the nodes eligibility (Tables VII and VIII). It is useful when all the nodes within a cluster possess low energy [39]. The clusters are formed with size equal to or greater than the network density then after these clusters migrate away from each other such that the overlap between them is reduced to zero. New clusters might be formed in this process [45], [81], [84].

**G. Energy Aware Unequal Clustering Fuzzy Algorithm**

The algorithm [49] proposes unequal clustering to overcome the clustering problem. In the first round, CHs are selected based on probabilistic models. In subsequent rounds, heads are selected based on their energy levels. Fuzzy parameters used are residual energy and distance of the nodes as shown in Table IX. Mamdani method is used as the fuzzy inference technique. Linguistic variables for the fuzzy set are close, medium and far for distance to base

station whereas for residual energy, the variables are low, medium and high [30]. Nodes can adjust their transmission range. Distance of next node is calculated based on Received Signal Strength. Nodes are all stationary. All the nodes are homogeneous. Node density is not considered [33].

TABLE III  
 RULE-BASE FUZZY INFERENCE SYSTEM FOR CHEF

Energy	Local distance	Chance
Low	Far	Very Low
Low	Medium	Low
Low	Close	Rather Low
Medium	Far	Medium Low
Medium	Medium	Medium
Medium	Close	Medium High
High	Far	Rather High
High	Medium	High
High	Close	Very High

TABLE IV  
 RULE-BASE FUZZY INFERENCE SYSTEM FOR FUZZY CONSTRAINT ROUTING

Buffer occupancy	Battery power	Hop count	Grade
Low	Low	Low	0
Medium	Medium	Medium	0
Medium	High	Medium	0
Medium	Medium	High	0
Medium	High	High	0
High	High	Medium	1
High	Medium	High	1
High	High	High	1

TABLE V  
 RULE-BASE FUZZY INFERENCE SYSTEM FOR IMPROVED FUZZY UNEQUAL CLUSTERING

Energy	Input variables		Output variables	
	Distance	Density	Chance	Radius
High	Far	High	High	Little Large
High	Far	Medium	Little High	Large
High	Far	Low	Medium	Large
High	Moderate	High	High	Little Large
High	Moderate	Medium	Medium	Medium
...	.....	...	...	...
Low	Near	Low	Low	Small

TABLE VI  
 RULE-BASE FUZZY INFERENCE SYSTEM FOR ENERGY-EFFICIENT CH SELECTION

Set of node number	Set of remaining energy	Probability of CH selection
Few	Very low	Very low
Few	Low	Very low
Few	Medium	Low
Few	High	Medium
Medium	Very low	Very low
Medium	Low	Low
Medium	Medium	Medium
Medium	High	High
Many	Very low	Low
Many	Low	Medium
Many	Medium	High
Many	High	Very high

TABLE VII

RULE-BASE FUZZY INFERENCE SYSTEM FOR FSCA INITIAL RULES		
Node's Time (T)	Node's Loyal Follower	Initiation Chance
Low	Low, Medium	0
Low	High	1
Medium	Low	0
Medium	Medium, High	1
High	Low, Medium, High	1

TABLE VIII

RULE-BASE FUZZY INFERENCE SYSTEM FOR FSCA MITIGATION RULES		
Node's loyal followers	Node's energy	Migration chance
Low	Low, Medium, High	1, 2, 3
Medium	Low, Medium, High	4, 5, 6
High	Low, Medium, High	7, 8, 9

TABLE IX

RULE-BASE FUZZY INFERENCE SYSTEM FOR ENERGY AWARE UNEQUAL CLUSTERING FUZZY ALGORITHM

Distance to base	Residual energy	Competition radius
Close	Low	Very small
Close	Medium	Small
Close	High	Rather Small
Medium	Low	Medium Small
Medium	Medium	Medium
Medium	High	Medium large
Far	Low	Rather large
Far	Medium	Large
Far	High	Very large

## VII. CLUSTER BASED PROTOCOL USING NEURO-FUZZY TECHNIQUE

Neuro-fuzzy [55], [79], [80], [82], [83] means combination of neural network and fuzzy logic. The memory, available power, processing speed is the linguistic input variables. The output variable is monitoring

coefficient. It works in dense environment. It uses fuzzy logic for increasing the network lifetime as shown in Table X.

### A. Cluster Adaptation Method

It gives better performance than statistical en-route filtering. It has been reported by developing fuzzy based system [53], [78]. It gives better routing in sensor networks. The input parameters are Partition Information of Cluster Region (PICR) [62], the Number of Sensors in the Cluster Region (NSCR) [64], Energy of Cluster Head (EOC) [11] and Distance from Cluster to base station (DFC) [31]. The output Fitness of the Cluster with Cluster head (CFWC) [27] is derived using Fuzzy rules. The fuzzy set for CFWC is Stop, Consider and Move.

TABLE X

RULE-BASE FUZZY INFERENCE SYSTEM FOR NEURO-FUZZY			
Power	Memory	Processing speed	Monitoring coefficient
Low	Low	Low	Not used
Medium	Medium	Medium	Critical
Medium	High	Medium	Event
Medium	Medium	High	Event
Medium	High	High	Event
High	High	Medium	Continuous
High	Medium	High	Continuous
High	High	High	Continuous

## VIII. CONCLUSION

Clustering is an important operation in WSN. In this paper, several fuzzy clustering techniques are analyzed. Comparative table is drawn for those fuzzy clustering techniques. Each has its own merits and demerits. No algorithm is perfectly suitable for commercial purposes. So it is still an open challenge for future research and development.

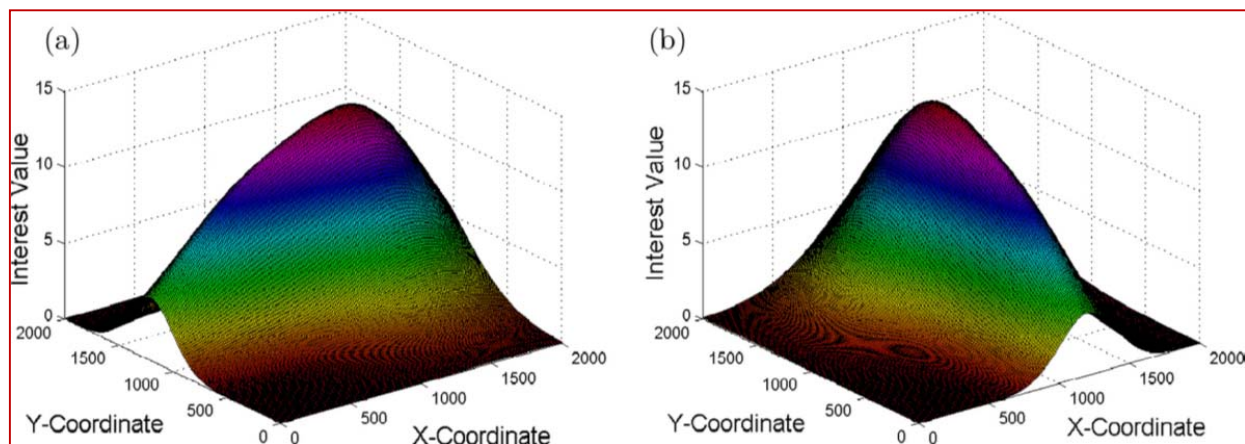

Fig. 15 Interest value

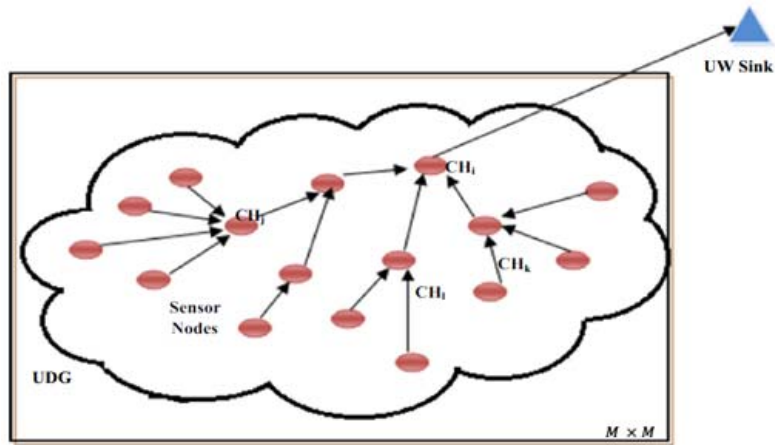

Fig. 16 CH formation

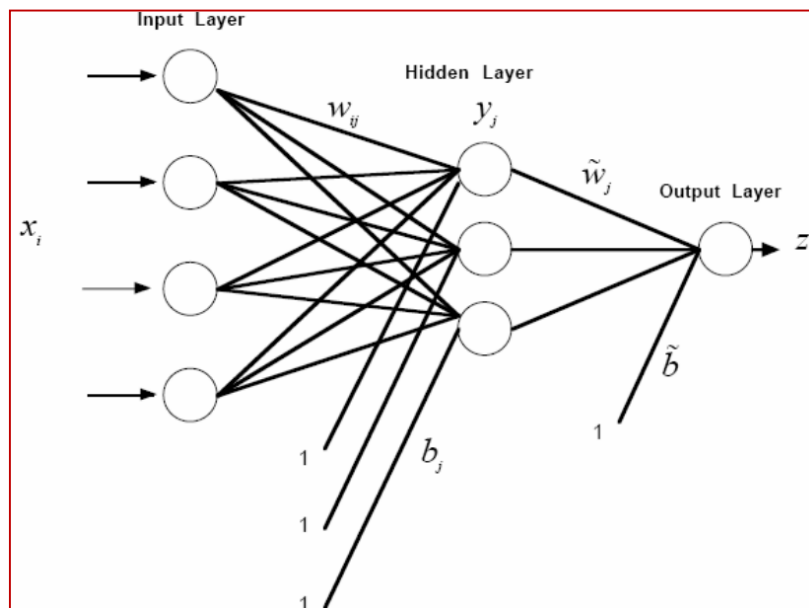

Fig. 17 Non-Linear Regressive Neural Network

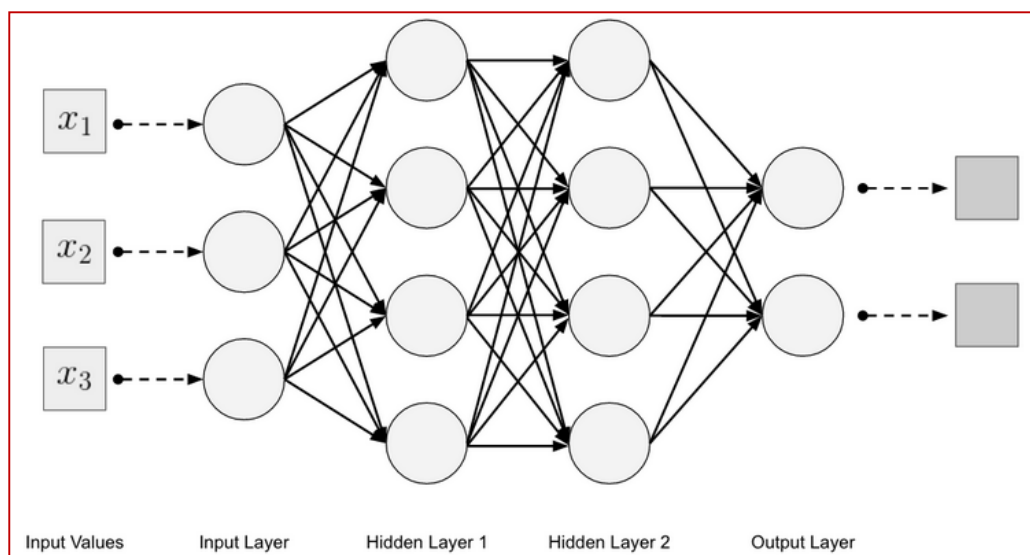

Fig. 18 Linear Regressive Neural Network



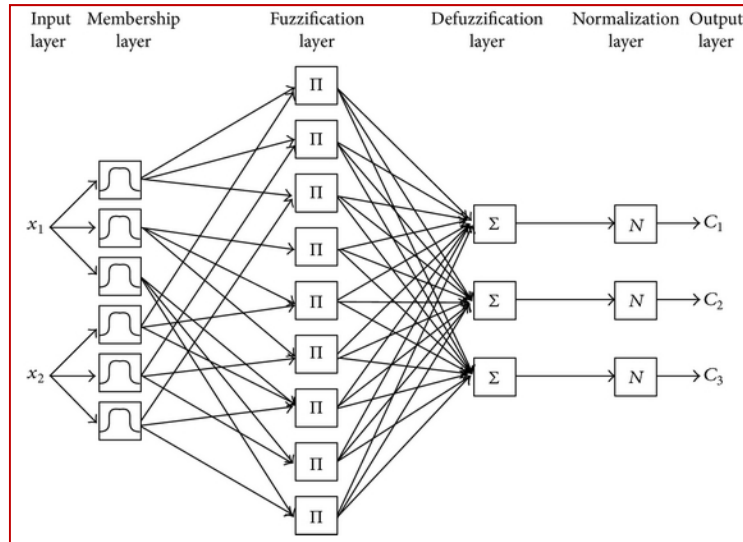

Fig. 19 Neuro-Fuzzy Layers

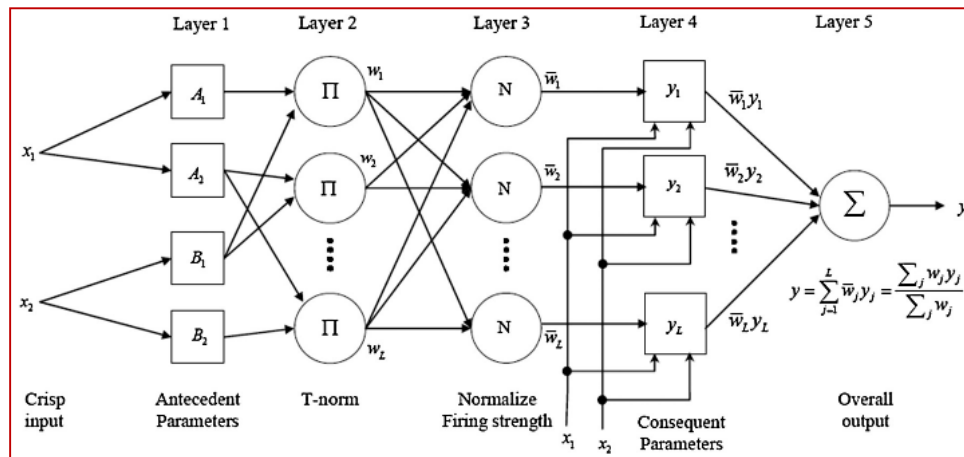

Fig. 20 Architecture of ANFIS

TABLE XI  
 INPUT AND OUTPUT PARAMETERS OF FUZZY LOGIC BASED CH SELECTION

Algorithm	Fuzzy Logic Type	Input Parameter	Output Parameter	Membership Function for Output Parameter	Features
CHEF [47]	Type 1 fuzzy set	Energy, Local Distance	Chance	Triangular	Reduce overhead, Prolong the lifetime
Fuzzy Multi constraint Routing [59]	Type 1 fuzzy set	Buffer occupancy, Energy, Hop count	Grade	Triangular	Reduce overhead, Maximizes throughput
Improved Fuzzy Unequal Clustering [58]	Type 1 fuzzy set	Energy, Distance, Density	Chance, Radius	Triangular	Prolong the lifetime of WSN
FCM [50]	Type 1 fuzzy set	Mean distance	-	-	Uniform distribution of clusters
NECHS [56]	Type 1 fuzzy set	Neighbor nodes, residual energy	Probability	Trapezoidal-very low, very high; Triangular-low, little low, medium; little high, high	Efficient than LEACH
FSCA [52]	Type 1 fuzzy set	Node lifetime, total number of loyal follower	Chance to being CH	Triangular	Efficient coverage, reduce amount of redundant messages
EEUCF [49]	Type 1 fuzzy set	Distance to base, Residual energy	Competition radius	Triangular	Prolong the lifetime of WSN by distributing the workload
Neuro-fuzzy technique [55]	Type 1 fuzzy set	Memory, Available power, Processing speed	Monitoring coefficients	Trapezoidal-not used, continuous triangular-critical, event	Used in monitoring systems
Cluster adaptation method [53]	Type 1 fuzzy set	EOC, PICR, DFC, NSCR	CFWC	Triangular	To evaluate the fitness of clustering

TABLE XII  
INPUT AND OUTPUT PARAMETER OF FUZZY LOGIC BASED CH SELECTION

Protocol Name	CH Stability	Delivery Delay	Scalability	Algorithm Complexity	Energy Efficiency
CHEF	Medium	Very Small	Very Low	Medium	Very Poor
Fuzzy Multi constraint Routing	High	Medium	Medium	Medium	Medium
Improved Fuzzy Unequal Clustering	Medium	Large	Very Low	High	Medium
FCM	High	Small	Low	High	Medium
NECHS	Medium	small	High	Medium	Medium
FSCA	Medium	small	Medium	Medium	High
EEUCF	High	Medium	Medium	Low	Very High
Neuro-fuzzy technique	High	Medium	High	Low	High
Cluster adaptation method	Medium	Large	Medium	Medium	High

REFERENCES

- [1] A.M Nirmala, A.M., Subramaniam, P., Anusha Priya, A., Ravi, M.: Cluster Head Selection Protocol using Fuzzy Logic for Wireless Sensor Networks. *IJASCSE*. 2 (3), (2013)
- [2] Chongdeuk Lee, Taegwon Jeong: FRCA: A Fuzzy Relevance-Based Cluster Head Selection Algorithm for Wireless Mobile Ad-Hoc Sensor Networks. Division of Electronic Engineering, Chonbuk National University, Jeonbuk, Korea.
- [3] Harold Robinson, Y., & Rajaram, M. (2015). "Trustworthy link failure recovery algorithm for highly dynamic mobile adhoc networks", World Academy of Science, Engineering and Technology, International Journal of Electrical, Computer, Energetic, Electronic and Communication Engineering, vol.9, no.2, 233–236.
- [4] Aslam, M., Rasheed, M.B., Shah, T., Rahim, A., Khan, Z.A., Qasim, U., Qasim, M.W., Hassan, A., Khan, A., Javaid, N.: Energy optimization and Performance Analysis of Cluster Based Routing Protocols Extended from LEACH for WSNs.
- [5] Heinzelman, W., Chandrakasan, A., Balakrishnan, H.: Energy-efficient routing protocols for wireless micro sensor networks. in Proc. 33rd Hawaii Int. Conf. System- Sciences(HICSS). Maui, HI, Jan. 2000.
- [6] Harold Robinson, Y., & Rajaram, M. (2015). "Energy-aware multipath routing scheme based on particle swarm optimization in mobile ad hoc networks", *The Scientific World Journal*, 1–9. doi:10.1155/2015/284276.
- [7] Erfan. Arbab, Vahe. Aghazarian, Alireza. Hedayati, Nima. Ghazanfari Motlagh: A LEACH-Based Clustering Algorithm for Optimizing Energy Consumption in Wireless Sensor Networks. 2nd International Conference on Computer Science and Information Technology (ICCSIT'2012) Singapore. April 28-29, (2012).
- [8] Lindsey, S., Raghavendra, C.S.: PEGASIS: Power-efficient Gathering in Sensor Information Systems. *Parallel and Distributed Systems*, 9 (924). (2002).
- [9] Robinson, Y. Harold, M. Rajaram, and Honey Raju. "Evolutionary Program Based Approach for Manipulator Grasping Color Objects." World Academy of Science, Engineering and Technology, International Journal of Computer, Electrical, Automation, Control and Information Engineering 8.12 (2015): 2235-2240.
- [10] Younis, O., Fahmy, S.: HEED: A Hybrid, Energy-efficient. Distributed Clustering Approach for Ad Hoc Sensor Networks. *Mobile Computer*, 3 (366). (2004).
- [11] Ye, M., Li, C., Chen, G., Wu, J.: EECS: An Energy Efficient Cluster Scheme in Wireless Sensor Networks. Proceedings of IEEE International Workshop on Strategies for Energy Efficiency in Ad Hoc and Sensor Networks. Phoenix, Arizona, (2005) April 7–9.
- [12] Princess, P. Joyce Beryl, and Y. Harold Robinson. "Discrete and Stationary Adaptive Sub-Band Threshold Method for Improving Image Resolution." World Academy of Science, Engineering and Technology, International Journal of Computer, Electrical, Automation, Control and Information Engineering 9.4 (2015): 1003-1006.
- [13] Haifeng Jiang, Yanjing Sun, Renke Sun, Hongli Xu Hindawi: Fuzzy-Logic-Based Energy Optimized Routing for Wireless Sensor Networks. *International Journal of Distributed Sensor Networks*. (2013).
- [14] Shurman, M.M., Alomari, Z.A., Mhaidat, K.M.: An Efficient Billing Scheme for Trusted Nodes Using Fuzzy Logic in Wireless Sensor Networks. *Wireless Engineering and Technology*. 5, 62-73. 2014.
- [15] Robinson, Y. H., Julie, E. G., & Princess, P. J. B. (2016). Manipulation of Image Segmentation Using Cleverness Artificial Bee Colony Approach. World Academy of Science, Engineering and Technology, International Journal of Computer, Electrical, Automation, Control and Information Engineering. 10(3), 607-614.
- [16] [http://en.wikipedia.org/wiki/Fuzzy\\_logic](http://en.wikipedia.org/wiki/Fuzzy_logic).
- [17] Antonio M. Ortiz. Fernando Royo. Teresa Olivares, Jose C. Castillo, Luis Orozco Barbosa, Pedro J. Marron.: Fuzzy-logic based routing for dense wireless sensor networks.
- [18] Robinson, Y. H., Julie, E. G., & Balaji, S. Bandwidth and Delay Aware Routing Protocol with Scheduling Algorithm for Multi Hop Mobile Ad Hoc Networks. World Academy of Science, Engineering and Technology, International Journal of Computer, Electrical, Automation, Control and Information Engineering, 10(8), 1512-1521.
- [19] Su, W., Bougiouklis, T. C.: Data fusion algorithms in cluster-based wireless sensor networks using fuzzy logic theory." In Proceedings of the 11th WSEAS international conference on communications.
- [20] Tarique Haiderl, Mariam Yusuf: A Fuzzy Approach to Energy Optimized Routing for Wireless Sensor Networks. *The International Arab Journal of Information Technology*. 6 (2), April 2009.
- [21] Balaji, S., Julie, E. G., Rajaram, M., & Robinson, Y. H. Fuzzy Based Particle Swarm Optimization Routing Technique for Load Balancing in Wireless Sensor Networks, World Academy of Science, Engineering and Technology, International Journal of Computer, Electrical, Automation, Control and Information Engineering Vol:10, No:7, 2016, pp. 1384 – 1393.
- [22] Wikipedia.: Routing basics"docwiki.cisco.com/wiki/routing\_basics
- [23] Naveen Sharma, Anand Nayyar: A Comprehensive Review of Cluster Based Energy Efficient Routing Protocols for Wireless Sensor Networks. 3 (1), January 2014.
- [24] Geethalakshmi, M., and Y. Harold Robinson. "Fault tolerant routing and scheduling scheme for multi hop wireless networks." *International Journal of Advanced Research in Computer Science and Software Engineering* 3, no. 3 (2013).
- [25] Jamal N. Al-Karaki Ahmed E. Kamal.: Routing Techniques in Wireless Sensor Networks: A Survey.
- [26] S.K Singh, M.P Singh and D.K Singh, "A Survey of Energy-Efficient Hierarchical Cluster-Based Routing in Wireless Sensor Networks," In *International Journal of Advanced Networking and Applications*, vol.02, pp.570-580, 2010.
- [27] Balaji, S., Rajaram, M., Robinson, Y. H., & Julie, E. G. (2016). A Hypercube Social Feature Extraction and Multipath Routing in Delay Tolerant Networks. World Academy of Science, Engineering and Technology, International Journal of Computer, Electrical, Automation, Control and Information Engineering, 10(6), 1220-1229.
- [28] Heinzelman, W.R., Chandrakasan, A., Balakrishnan: Energy-Efficient Communication Protocol for Wireless Microsensor Networks. In Proceedings of the 33rd Annual Hawaii International Conference on System Sciences, Maui, HI, USA, pp. 10–19, 4–7 January 2000.
- [29] Younis, S., Fahmy, O.: HEED: A hybrid, energy-efficient, distributed clustering approach for ad-hoc sensor networks. *IEEE Trans. Mobile Computer*, 366–379, 2004.
- [30] Balaji, S., Harold Robinson, Y. and Rajaram, M. (2016) SCSBE: Secured Cluster and Sleep Based Energy-Efficient Sensory Data Collection with Mobile Sinks. *Circuits and Systems*, Vol.8, No. 7, pp. 1992-2001. <http://dx.doi.org/10.4236/cs.2016.78173>.
- [31] Wendi Rabiner Heinzelman, Anantha Chandrakasan, Hari Balakrishnan: Energy Efficient Communication Protocol for Wireless Microsensor Networks. In the Proceedings of the Hawaii International Conference on System Sciences, January 4-7, 2000, Maui, Hawaii.
- [32] Manjeshwar, D.P., Agrawal, E.: TEEN: A Routing Protocol for Enhanced Efficiency in Wireless Sensor Networks. In Proceedings of

- the 15th International Parallel and Distributed Processing Symposium (IPDPS), San Francisco, CA, USA, pp. 2009–2015, 23–27 April 2001.
- [33] Robinson, Y.H., Balaji, S. and Rajaram, M. (2016) "ECBK: Enhanced Cluster Based Key Management Scheme for Achieving Quality of Service", *Circuits and Systems*, Vol. 8, No. 7, pp. 2014-2024. <http://dx.doi.org/10.4236/cs.2016.78175>.
- [34] YaXu, John Heidemann, Deborah Estrin: Geography informed Energy Conservation for Ad Hoc Routing. *Proceedings of the Seventh Annual ACM/IEEE International Conference on Mobile Computing and Networking (ACM Mobicom)*, 2001.
- [35] Heinzelman, W.R., Chankrakasana A., Balakrishnan, H.: Energy Efficient Communication Protocol for Wireless Microsensor Network. *Int. Conf. Sys. Scien.* 8, 2000, pp. 3005–3014.
- [36] Harold Robinson, Y., Rajaram, M., Golden Julie, E. and Balaji, S. (2016) Dominating Set Algorithm and Trust Evaluation Scheme for Secured Cluster Formation and Data Transferring. *World Academy of Science, Engineering and Technology, International Journal of Computer, Electrical, Automation, Control and Information Engineering*, vol. 10, No. 2, pp. 388-393.
- [37] Zhao F., Guibas, L.: *Wireless Sensor Networks: An Information Processing Approach*. Morgan Kaufmann Publishers –San Francisco 2004.
- [38] Klir G.J., Yuan, B.: *Fuzzy Sets and Fuzzy Logic: Theory and Applications*. Prentice Hall –New Jersey 1995.
- [39] Harold Robinson, Y., Rajaram, M., Golden Julie, E. and Balaji, S. (2016), "Tree Based Data Fusion Clustering Routing Algorithm for Illimitable Network Administration in Wireless Sensor Network", *World Academy of Science, Engineering and Technology, International Journal of Computer, Electrical, Automation, Control and Information Engineering Vol:10, No:6*, pp. 1123 – 1130.
- [40] Weilian Su the Odoros C. Bougiouklis: Data Fusion Algorithms in Cluster-based Wireless Sensor Networks Using Fuzzy Logic Theory. *Proceedings of the 11th WSEAS International Conference on communication, Agios Nikolaos, Crete Island, Greece, July 26-28, 2007*.
- [41] Ehsan Amiri, Hassan Keshavarz, Mojtaba Alizadeh, Mazdak Zamani, Touraj Khodadadi: Energy Efficient Routing in Wireless Sensor Networks Based on Fuzzy Ant Colony Optimization. *International Journal of Distributed Sensor Networks*. 2014, 17.
- [42] Harold Robinson, Y., Rajaram, M., Golden Julie, E. and Balaji, S. (2016), "TBOR: Tree Based Opportunistic Routing for Mobile Ad Hoc Networks", *World Academy of Science, Engineering and Technology, International Journal of Computer, Electrical, Automation, Control and Information Engineering Vol:10, No:6*, pp. 1115 – 1122
- [43] Shio Kumar Singh, Singh, M.P., Singh, D.K.: Routing Protocols in Wireless Sensor Networks: A Survey. *International Journal of Computer Science & Engineering Survey (IJCSSES)*. 1 (2), November 2010.
- [44] Intanagonwivat, Govindan, R., Estrin, D.: Directed Diffusion: A Scalable and Robust Communication Paradigm for Sensor Networks. *Proc. Sixth Ann. ACM/IEEE Int'l Conf. Mobile Computing and Networking (MOBICOM)*, pp. 56-67, Aug. 2000.
- [45] Ramalakshmi, S., & Robinson, Y. H. (2014). "ATMPH: Attaining optimal throughput capacity of MANET with power control in heterogeneous network", *Programmable Device Circuits and Systems*, 6(4), 111–115.
- [46] Haas, Z.J. Halpern, J.Y. Li, L.: Gossip-Based Ad Hoc Routing. In *Proceedings of the 19th Conference of the IEEE Communications Society (INFOCOM)*, New York, NY, USA, June 2002; 23–27, pp. 1707–1716.
- [47] Younis, O., Fahmy, S.: HEED: A Hybrid, Energy-Efficient, Distributed Clustering Approach for Ad Hoc Sensor Networks. *IEEE Transactions on Mobile Computing*, 2004, 3(4), 660–669.
- [48] Harold Robinson, Y., & Rajaram, M. (2014). "A novel approach to allocate channels dynamically in wireless mesh networks", *World Academy of Science, Engineering and Technology, International Journal of Computer, Electrical, Automation, Control and Information Engineering*, vol. 8, no.10, pp. 1865–1868.
- [49] Laiali Almazaydeh, Eman Abdelfattah, Manal Al-Bzoor, Amer Al-Rahayfeh: Performance evaluation of routing in wireless sensor networks. *International Journal of Computer Science and Information Technology*, 2 (2), April 2010.
- [50] Kim, J.M., Park, S., Han, Y., Chung, T.: CHEF: Cluster Head Election mechanism using Fuzzy logic in Wireless Sensor Networks. In *Proceeding of the 10th International Conference on Advanced Communication Technology (ICACT)*, pp. 654–659. 2008.
- [51] Robinson, Y. H., & Rajeswari, S. R. (2011). "Energy-based dynamic encryption for wireless sensor networks. *Wireless Communication*", vol.3, no.9, pp. 661–663.
- [52] Hakan Bagci, Adnan Yazici: An energy aware fuzzy approach to unequal clustering in wireless sensor networks. *Applied Soft Computing*. 13, pp. 1741–1749, 2013.
- [53] Hoang, D.C., Kumar, R., Panda, S.K.: Fuzzy C-Means Clustering Protocol for Wireless Sensor Networks', in *Proceeding of the IEEE International Symposium on Industrial Electronics (ISIE)*, pp. 3477–3482. 2010.
- [54] Golden Julie, E., Tamil Selvi, S., & Harold Robinson, Y. (2016). "Performance Analysis of Energy Efficient Virtual Back Bone Path Based Cluster Routing Protocol for WSN", *Wireless Personal Communications*, Springer, 1–19, DOI 10.1007/s11277-016-3520-5.
- [55] Tashtoush, Y.M., Okour, M.A.: Fuzzy Self-Clustering for Wireless Sensor Networks. In *proceeding of the IEEE/IFIP International Conference on Embedded and Ubiquitous Computing*, pp. 223–229. 2008.
- [56] Kim, B.H., Moon, S.Y., Lee, H.Y., Sun, C.I., and Cho, T.H.: Cluster Adaptation Method to Enhance Performance of Filtering scheme in Sensor Network. In *Proceeding of the 11th International Conference on Advanced Communication Technology*, pp. 411–416. 2009.
- [57] Harold Robinson, Y., Rajaram, M., Golden Julie, E. and Balaji, S. (2016), "Detection of Black Holes in MANET Using Collaborative Watchdog with Fuzzy Logic", *World Academy of Science, Engineering and Technology, International Journal of Computer, Electrical, Automation, Control and Information Engineering Vol:10, No:3*, pp. 575 – 581.
- [58] Veena, K.N., Vijaya Kumar, B.P.: Dynamic Clustering for Wireless Sensor Networks: A Neuro-Fuzzy Technique Approach' in *Proceeding of the IEEE International Conference on Computational Intelligence and Computing Research (ICIC)*, pp. 1–6. 2010.
- [59] Hu, Y., Shen, X., Kang, Z.: Energy-efficient Cluster Head Selection in Clustering Routing for Wireless Sensor Networks. In *Proceedings of the 5th International Conference on Wireless Communications, Networking and Mobile Computing, WiCom'09*, pp. 1–4. 2009.
- [60] G. Arun Sam Paul Thomas, R. Karthik Ganesh, A. Kandasamy, S. Balaji, Y. Harold Robinson, (2011) "An Advanced Controlled-Flooding Routing with Group Organization for Delay Tolerant Networks using A-SMART", *Emerging Trends in Electrical and Computer Technology (ICETECT)*, 978-1-4244-7926-9/11, IEEE.
- [61] Songmao, Chenglinzhao, Zhengzhou, yabin.: An improved fuzzy unequal clustering algorithm for wireless sensor network. 6th international ICST conformance on communication and networking in china (CHINACOM), 2011.
- [62] Mala Chelliah, Siddhartha Sankaran, Shishir Prasad, Nagamaputurgopalan, Balasubramaniansivaselvan: Routing for wireless mesh networks with multiple constraints using fuzzy logic. *International Arab Journal of Information Technology*. 9 (1), jan. 2012.
- [63] Harold Robinson, Y, Golden Julie E, Balaji S, Ayyasamy A, (2016), Energy Aware Clustering Scheme in Wireless Sensor Network Using Neuro-Fuzzy Approach , *Wireless Personal Communications*, Springer, 1-19, Doi: 10.1007/s11277-016-3793-8
- [64] Chongdeuk lee, Taegwonjeong.: FRCA: A fuzzy relevance –based cluster head selection algorithm for wireless mobile ad-hoc sensor networks. *Sensors*. 11, 5383-5401, 2011.
- [65] Anitha Shanmugam, Dr. Abirami Thiayagarajan, "Mining of Behavioral Patterns Using Prefix Sharing ASP-Tree in Wireless Sensor Networks", *International Journal of Advances in Computer and Electronics Engineering*, Volume 2, Issue 3, March 2017, pp. 28 – 32.
- [66] Balaji, S., E. Golden Julie, and Y. Harold Robinson. "Evaluation of Context Information for Intermittent Networks." *World Academy of Science, Engineering and Technology, International Journal of Computer, Electrical, Automation, Control and Information Engineering* 10.9 (2017): 1693-1704.
- [67] Rakhi Sharma, Dr. D. V. Gupta, "Effects of Selfish node on Routing Protocols in Delay Tolerant Network", *International Journal of Advances in Computer and Electronics Engineering*, Volume 2, Issue 3, March 2017, pp. 08 - 10.
- [68] Xing, G., Jia, W. and Li, M., Rendezvous Algorithms for Wireless Sensor Networks with a Mobile Base Station. *IEEE Transaction on Mobile Computation*, 11(1), pp.47-60, 2012.
- [69] Robinson, Y. Harold, and M. Rajaram. "Establishing pairwise keys using key Predistribution schemes for sensor networks." *World Academy of Science, Engineering and Technology, International*

- Journal of Computer, Electrical, Automation, Control and Information Engineering 9.2 (2015): 608-612.
- [70] Kim, D.S. and Chung, Y.J., June. Self-organization routing protocol supporting mobile nodes for wireless sensor network. In *Computer and Computational Sciences, 2006. IMSCS'06. First International Multi-Symposiums on (Vol. 2, pp. 622-626)*. IEEE, 2006.
- [71] Vincze, Z., Vass, D., Vida, R., Vidács, A. and Telcs, A., Adaptive sink mobility in event-driven multi-hop wireless sensor networks. In *Proceedings of the first international conference on Integrated internet ad hoc and sensor networks (p. 13)*. ACM, May 2006.
- [72] Golden Julie, E., Tamil Selvi, S., & Harold Robinson, Y. "Opportunistic routing with secure coded wireless multicast using MAS approach", *World Academy of Science, Engineering and Technology, International Journal of Computer, Electrical, Automation, Control and Information Engineering*, vol. 8, no.7, pp. 1247-1250, 2014.
- [73] Jain, S., Shah, R.C., Brunette, W., Borriello, G. and Roy, S., Exploiting mobility for energy efficient data collection in wireless sensor networks. *Mobile Networks and Applications*, 11(3), pp.327-339, 2006.
- [74] Deng, S., Li, J. and Shen, L., Mobility-based clustering proto-col for wireless sensor networks with mobile nodes. *IET wireless sensor systems*, 1(1), pp.39-47, 2011.
- [75] Balaji, S., Golden Julie, E. & Harold Robinson, Y. "Development of Fuzzy based Energy Efficient Cluster Routing Protocol to Increase the Lifetime of Wireless Sensor Networks", *Mobile Netw Appl* (2017), pp. 1-13. <https://doi.org/10.1007/s11036-017-0913-y>
- [76] Erman, A.T., van Hoesel, L., Havinga, P. and Wu, J., 2008. Enabling mobility in heterogeneous wireless sensor networks cooperating with UAVs for mission-critical management. *IEEE Wireless Communications*, 15(6), pp.38-46.
- [77] Chatzigiannakis, I., Kinalis, A. and Nikolettas, S., Sink mobility protocols for data collection in wireless sensor networks. In *Proceedings of the 4th ACM international workshop on Mobility management and wireless access (pp. 52-59)*. ACM, 2006.
- [78] Robinson, Y. Harold, and M. Rajaram. "A memory aided broadcast mechanism with fuzzy classification on a device-to-device mobile Ad Hoc network." *Wireless Personal Communications* 90.2 (2016): 769-791.
- [79] Chandran, S.R., Manju, V.S., Alex, A.P., A Neuro-Fuzzy Approach to Route Choice Modelling. *International Journal of Science and Applied Information Technology Vol.2 , No.2, Pages : 09-11, 2013.*
- [80] Sasikala K., Rajamani V., A Neuro Fuzzy based conditional shortest path routing protocol for wireless mesh network, *International Journal of Enhanced Research in Management and Computer Applications*, vol. 2 issue 5, 2013.
- [81] Robinson Y, Harold, Julie E, Golden, Ayyasamy A, Archana M, "Cluster based Routing in Sensor Network using Soft Computing Techniques: A Survey", *Asian Journal of Research in Social Sciences and Humanities*, Vol. 7, No. 3, pp. 341-360.
- [82] Pon Rohini R, Shirly S, Joy Winnie Wise D.C., Multipath Routing Using Neuro Fuzzy in Wireless Sensor Network, *International Journal for Research in Applied Science and Engineering Technology*, vol 3 issue IV, 2015.
- [83] Fard, M.V., Mazinani, S.M. and Hoseini, S.A., Introducing a novel fault tolerant routing protocol in wireless sensor networks using fuzzy logic. *International Journal of Computer Science & Information Technology*, 5(5), p.171, 2013.
- [84] Robinson, Y. Harold, E. Golden Julie, A. Ayyasamy, and M. Archana. "Cluster based Routing in Sensor Network using Soft Computing Techniques: A Survey." *Asian Journal of Research in Social Sciences and Humanities* 7, no. 3 (2017): 341-360.
- [85] Y. Xu, A. Saifullah, Y. Chen, C. Lu, S. Bhattacharya, Near optimal multi application allocation in shared sensor networks, in: *Proceedings of the Eleventh ACM International Symposium on Mobile Ad Hoc Networking and Computing, MobiHoc '10*, ACM, New York, NY, USA, 2010, pp. 181-190. doi:10.1145/1860093.1860118. URL <http://doi.acm.org/10.1145/1860093.1860118>.
- [86] R. Huang, X. Chu, J. Zhang, Y. H. Hu, Energy-efficient monitoring in software defined wireless sensor networks using reinforcement learning: A prototype, *International Journal of Distributed Sensor Networks* 2015. doi:10.1155/2015/360428.
- [87] Abouelfadl, A. A., El-Bendary, M. A. M., & Shawki, F. (2014). Enhancing transmission over wireless image sensor networks based on ZigBee network. *Life Science Journal*, 11(8), 342-354.
- [88] El-Bendary M. A. M., Kasban, H., & El-Tokhy, M. A. R. (2014). Interleaved reed-solomon codes with code rate switching over wireless communications channels. In: *International Journal of Information Technology and Computer Science (IJITCS)* (<http://www.ijitcs.com>) on, 16(1).
- [89] Stankovic, J. A., Wood, A. D., & He, T. (2011). Realistic applications for wireless sensor networks. In S. Nikolettas & J. D. P. Rolim (Eds.), *Theoretical aspects of distributed computing in sensor networks* (pp. 835-863). Berlin: Springer.
- [90] Momani, M., & Challa, S. (2010). Survey of trust models in different network domains. arXiv preprint arXiv:1010.0168.



**Dr. Y. Harold Robinson** is currently working as an Associate Professor and Head, Department of Computer Science and Engineering in SCAD College of engineering and Technology, Tirunelveli. He Completed PhD in Anna University, Chennai. He finished ME degree in Anna University, Chennai. He received his Ph.D. from Anna University Chennai. His research interests are Wireless Networks Mobile Computing, Wireless Sensor Networks. He has published several Research papers in International Journals. He has presented many papers in National and International conferences in Network security, Mobile Computing and Cloud Computing.



**Dr. E. Golden Julie** received her B.E degree in Computer Science and Engineering in 2005 from Anna University Chennai and ME degree in Computer Science and Engineering in 2008 from Anna University Chennai. She received Ph.D from Anna University Chennai. Presently she is working as assistant professor in Regional centre Anna University, Tirunelveli, India She has published many research papers in various fields. Her research area includes Wireless Sensor Adhoc Networks and Image Processing. She is a member of ISTE.