

# Design and Development of On-Line, On-Site, In-Situ Induction Motor Performance Analyser

G. S. Ayyappan, Srinivas Kota, Jaffer R. C. Sheriff, C. Prakash Chandra Joshua

**Abstract**—In the present scenario of energy crises, energy conservation in the electrical machines is very important in the industries. In order to conserve energy, one needs to monitor the performance of an induction motor on-site and in-situ. The instruments available for this purpose are very meager and very expensive. This paper deals with the design and development of induction motor performance analyser on-line, on-site, and in-situ. The system measures only few electrical input parameters like input voltage, line current, power factor, frequency, powers, and motor shaft speed. These measured data are coupled to name plate details and compute the operating efficiency of induction motor. This system employs the method of computing motor losses with the help of equivalent circuit parameters. The equivalent circuit parameters of the concerned motor are estimated using the developed algorithm at any load conditions and stored in the system memory. The developed instrument is a reliable, accurate, compact, rugged, and cost-effective one. This portable instrument could be used as a handy tool to study the performance of both slip ring and cage induction motors. During the analysis, the data can be stored in SD Memory card and one can perform various analyses like load vs. efficiency, torque vs. speed characteristics, etc. With the help of the developed instrument, one can operate the motor around its Best Operating Point (BOP). Continuous monitoring of the motor efficiency could lead to Life Cycle Assessment (LCA) of motors. LCA helps in taking decisions on motor replacement or retaining or refurbishment.

**Keywords**—Energy conservation, equivalent circuit parameters, induction motor efficiency, life cycle assessment, motor performance analysis.

## I. INTRODUCTION

### A. Problem Statement

ENERGY efficiency is an important component of the energy economy. It is often called an “energy resource”, because it helps to decrease the use of primary energy resources and achieve considerable savings. The Global electricity demand by application wise [1] is shown in Fig. 1. Three main sectors which account for approximately 70% of the total electricity consumption in the industrialized countries:

G. S. Ayyappan and Srinivas Kota are with the Council of Scientific and Industrial Research-Central Scientific Instruments Organisation (CSIR-CSIO), Chennai Centre, CSIR Madras Complex, Taramani, Chennai, 600 113, India (e-mail: ayyappangs@csircmc.res.in, siccio@csircmc.res.in).

Jaffer R.C. Sheriff is with Danfoss Industries Private Limited, Chennai, 631 604, India (e-mail: jaf.sheriff@gmail.com).

Prakash Chandra Joshua. C is with National Institute Ocean Technology (NIOT), Pallikaranai, Chennai, 600 100, India (e-mail: prakashchandrajoshua@gmail.com).

This research work was funded by Instrument Development Program, Department of Science & Technology (IDP-DST), New Delhi, India (<http://www.dst.gov.in/instrumentation-development-programme>).

- Motors (40–45%),
- Lighting (15%),
- Home Appliances and Consumer Electronics (15%).

The industrial sector in India is the major energy user accounting for about 44.84% of total electrical energy consumption [2]. Induction motors are considered to be the largest users of electrical energy among all motors. Induction motors are extensively used in industrial, commercial, and household appliances and consume around 50% to 60% of the total energy consumption in the industries.

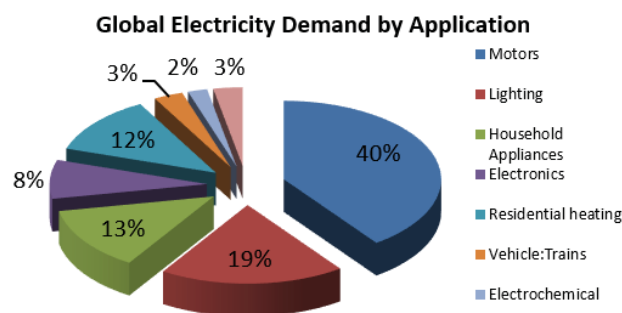

Fig. 1 Global Electricity demand by application

TABLE I  
GLOBAL MOTOR ELECTRICITY CONSUMPTION BY SECTOR

Sector	Electricity consumption of Motor (TWh/year)	% of energy handled by motors
Industrial	4,488	64%
Commercial	1,412	20%
Residential	948	13%
Transport and agriculture	260	3%

TABLE II  
SECTOR WISE ENERGY SAVING POTENTIAL ON MOTORS IN INDIA

Sector	Energy Handled by Motors (%)	Conservation Potential (%)
Industrial Sector	70-75%	Up to 25%
Agriculture Sector	20-25%	Up to 30%
Domestic Sector	2-3%	Up to 20%
Commercial Sector	4-5%	Up to 30%

Table I shows the aggregate of the energy consumed by different types of motors operating within a wide set of applications in every sector during 2011 globally, with the greatest opportunity for savings in the industrial sector [3]. The annual electricity consumption of motors used in India is around 950 TWh/year [4].

As per the statistical report presented by Bureau of Energy

Efficiency (BEE) through “Standards & Labelling (S&L) Program for Motor in India”, in MEPSA 2009, the Sector Wise Energy Saving Potential on Motors is shown in Table II.

### B. Need & Relevance

In the present scenario of energy crises and possibilities for huge energy saving potential on motors, conserving energy in the electrical machines becomes very important and mandate for the industries. Energy conservation does not mean that rewinding or changing the motor blindly. It is a systematic approach to maintain or to reduce energy consumption of the motors. Industries should strive for energy conservation as the cost of production is spiraling upwards. As per the AFF reports and IEEMA Statistics & Primary Survey, there is possibility to conserve energy around 20 to 30% through motors.

In order to conserve energy, it is necessary to operate the motors very efficiently. Measuring the operating efficiency of motor on-line helps in identifying the motors for

- Refurbishment/ Replacement with new motor through Life Cycle Assessment (LCA) [5],
- Checking the efficiency of the motor after rewinding [6],
- Operating the motor around its Best Efficiency Point (BOP) wherever it is possible.

Motor Performance Analyser (MPA) is going to play a vital role in industries for monitoring the motor performance as well as conserving energy on induction motors. The MPA could be suitable for conducting on-site energy audits of existing motors which provides scientific data to replace or refurbish the existing motor aiming to conserve energy. The advantage of the developed system over the existing methods is that there is no need to disconnect the motor from the load and measuring the output torque.

## II. METHODOLOGY

### A. Existing Methodology

In General,

$$\text{Motor Efficiency} = \text{Motor (Output/Input)} \quad (1)$$

where, Motor Output =  $2 \times \pi \times N \times T / 60 \dots W$ , N: Speed in rpm, T: Mechanical Torque developed in Nm, Motor Input =  $3 \times V_{ph} \times I_{ph} \times \cos\phi$ ,  $W = \sqrt{3} \times V_L \times I_L \times \cos\phi \dots W$ . Alternatively,

$$\text{Motor Efficiency} = (\text{Input} - \text{Losses}) / \text{Input} = 1 - (\text{Losses}/\text{Input}) \quad (2)$$

The efficiency can be calculated by using (1). Particularly, the output power of a motor is hard to detect at the site. One of established procedures is therefore to calculate the efficiency by measuring the losses and subtract them from the input to find the output as shown in (2).

There are many methods available for the motor efficiency evaluation in the literature and the new methods are appearing every year [7]. One of the standards is the IEEE 112 [8], which recognizes five methods for determining motor efficiency and its drawbacks as shown in Table III.

The IEEE 112 methods shown in Table III are not suitable for field evaluation because these processes involve the removal of motor from service to place it on a test stand and couple it to the test benches [9]. It can be seen that these methods are impractical for on-site/on-line measurements and costly.

TABLE III  
IEEE 112 METHODS AND ITS DRAWBACKS

Type	Description	Problems
Test – A	Mechanical Brake Test	Suitable for fractional HP motors and not suitable for on-site measurement
Test – B	Dynamometer Method	Cost of Torque measurement is High, complex and losses can be separated
Test – C	Duplicate Machine	Time consuming process to setup & run
Test – D	Input Measurements	Not accounting for Stray Load Losses
Test – E	Equivalent Circuit Method	Not suitable for on-site measurement and also not accounting for Stray Load Losses.

### B. MPA Development

The developed MPA displays the operating efficiency of motor by monitoring the electrical power input (like voltage, current, and power) and shaft speed of the motor. The MPA determines the operating efficiency of motors without removing the motors from the field and without the need for measuring the output power or torque. The calculation of the operating efficiency is based on the equivalent circuit method. The motor parameters are estimated by using a few sets of data from the field test and nameplate information coupled with the developed genetic algorithm [10] instead of using the no-load and blocked-rotor test results. Conducting no-load and blocked rotor tests on the site are undoubtedly a tedious and time-consuming task if the motor is already coupled with driven equipment in the process.

If the MPA unit is connected to the motor for the first time, the unit has to be configured to that particular motor. During configuration, the system finds the equivalent circuit parameter of the motor at any operating load point by running the developed algorithm [11]-[13], and then, the estimated parameters are stored in SD card. The stator copper loss, rotor copper loss, magnetizing losses (eddy current and hysteresis), windage and friction losses of the motor under analysis are calculated based on the equivalent circuit parameters available in the SD Card and online electrical input parameters measured. The stray load losses are assumed based on the IEEE 112 standard based on the capacity of the motor [8]. The efficiency of the induction motor is computed by means of total losses involved in the motor and the electrical power input. The output power and torque are indirectly derived from the results. This requires an accurate measurement of 3-phase energy (kWh) with an accuracy Class 0.5 or less, which is achieved by using accurate signal conditioners and CTs.

## III. HARDWARE OF MPA

Fig. 2 shows the view of the developed MPA unit:



Fig. 2 View of the developed MPA

The sub-systems of the MPA are listed below and shown in Fig. 3. The functional block diagram of the MPA system is shown in Fig. 4.

- Microcontroller Unit (MU)
- Power Measuring Unit (PMU)
- Speed Sensor Module (SSM)
- Keypad Interface Module (KIM)
- RTC Unit (RU)
- Communication Unit (CU)
- Power Supply Unit (PSU)

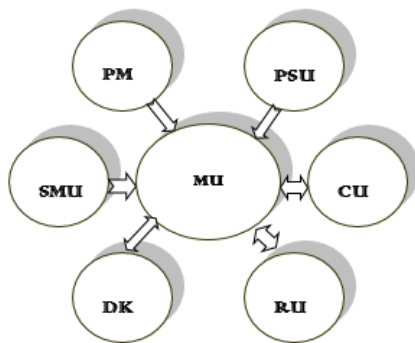

Fig. 3 Subsystems of MPA Hardware

#### A. Microcontroller Unit (MU)

The developed MPA is built around the ARM Cortex M3 Microcontroller, which is a low-cost controller suitable to make it cost effective solution. Necessary hardware interfacing circuitries like the reset circuitry, clock oscillatory circuitry, etc. are provided in the MU.

#### B. Power Measuring Unit (PMU)

The Power Measuring unit is used to measure the electrical parameters like the phase-wise voltage, current, power factors, each phase power and cumulative powers (kW, kVA, kVAr), cumulative energies (kWh & kVArh), status and frequency of the 3-phase LT/ HT Induction Motor with an accuracy Class of 0.5 or less.

#### C. Speed Sensor Module (SSM)

In order to find the efficiency of the motor, the MPA requires the measurement of motor shaft speed. Since the measurement of speed is to be carried out in the field and being continuous, a non-contact speed measurement is

preferred. The Speed Measuring unit is built around optical proximity speed sensor with necessary circuits.

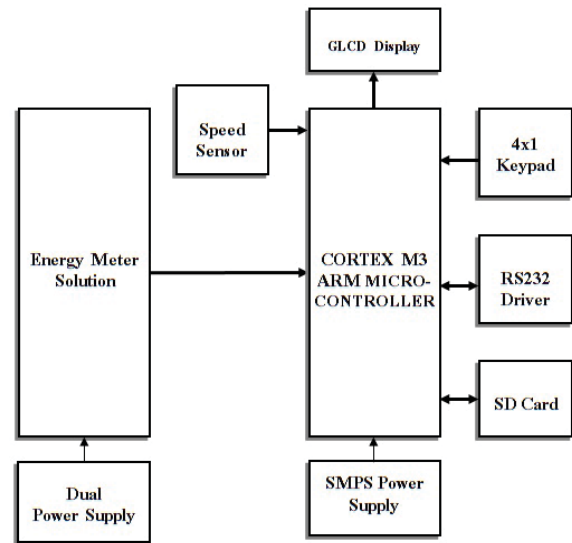

Fig. 4 Functional Block Diagram of MPA

An optical proximity sensor is used to measure the motor shaft speed. This method requires only a small reflective sticker has to be placed on the shaft of the motor and the sensor can be placed even 10 cm apart. The sensing speed, accuracy of 1 rpm can be easily obtained using this setup.

#### D. Keypad Interface Module (KIM)

The Human Machine Interface (HMI) is provided by using a 2.5" TFT touch screen. 4x1 membrane keypad is also provided for easy user interface. The user can feed some of the configuration parameters and to select the different display parameter screen using keypad.

#### E. RTC Unit (RU)

In order to facilitate the real-time operation, a real time clock with non-volatile RAM backed up with battery is provided.

#### F. Communication Unit (CU)

The system is facilitated with RS232/ USB interface which can be used to connect the MPA to PC directly. This is required to download the logged data on the site for further analysis.

#### G. Power Supply Unit (PSU)

The power supply required to power up the Main Controller Module (MCM) and Speed Sensor Module (SSM). A SMPS based power supply is used which has over voltage, short circuit, and thermal overshoot protection.

## IV. SOFTWARE OF MPA

The software developed for the operation of MPA is called as the firmware software or embedded software. The program is written in high level language like C and using the KEIL MDK-ARM Vision 4.0 as an Integrated Development

Environment (IDE). The final output of the program, 'axf' file is then stored in the Flash Memory of the MPA. The overall

functions of MPA are shown as a flowchart in Fig. 5.

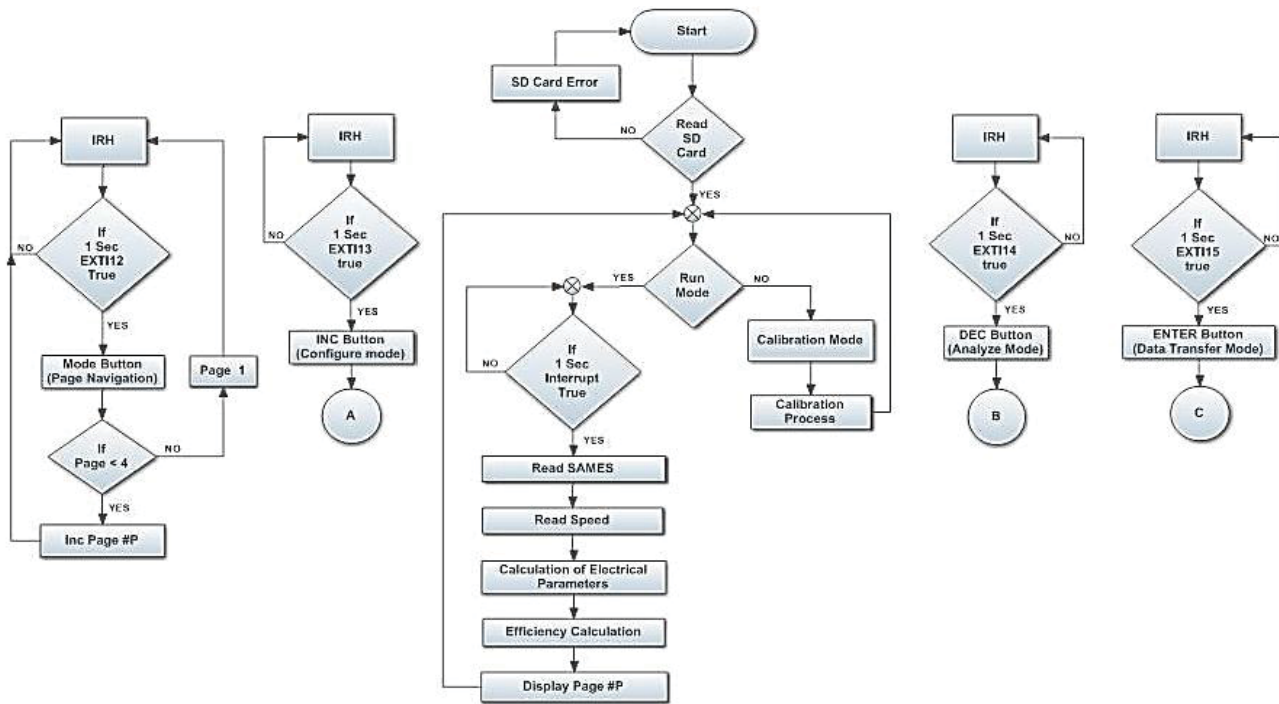

Fig. 5 Overall Functions of MPA as Flowchart

The software modules required for the functioning of MPA were developed and implemented. Some of the modules used to in the applications are listed below:

- i. Initialization Algorithms
- ii. Configuration of MPA
- iii. Display Parameters
- iv. Three Modes of Operations (Run Mode, Spot Analysis Mode and Continuous Analysis Mode)
- v. Data Storage Algorithm
- vi. Data Transfer Mode
- vii. Calibration Mode
- viii. Application Software for PC

**Spot Analysis Mode:** In this mode, the system operates in interactive mode. The user has the provision to perform load vs. efficiency characteristics, torque vs. speed characteristics, and so on. At every point of load conditions, an average of 10 sets readings is taken and stored on the SD card with timestamp. At the end analysis or future, the data stored in the system can be downloaded into the PC with the developed front-end software.

**Continuous Analysis Mode:** In many cases, the motor auditors may require the motor performance data for a period of a week or months together. This can be achieved by using this mode. In this mode, the motor data at any predefined interval can be stored on the SD Card for future analysis. The system can accommodate a maximum size of 4 GB, which provides data logging for more than 100 years (with a storage interval of 1 minute).

## V. RESULTS AND DISCUSSIONS

The MPA unit was designed, developed, calibrated, and tested for its functionality. The developed unit was then evaluated to the IEC-60034-2-1 Standard [14]. In order to evaluate the developed MPA, the Motor Test Centre established in the lab was used, which is shown in Fig. 6. Table IV shows the specification/features of the Motor Test Centre used in the lab.

TABLE IV  
 SPECIFICATION OF REFERENCE MOTOR TEST CENTRE

Parameters	Specifications
Range of Motors can be tested	Bed - 1: 1 to 5 HP Bed - 2: 7.5 to 15 HP Bed - 3: 20 to 50 HP
Type of Dynamometer used for loading	Digitally Controller Eddy Current Dynamometer (IEEE 112-B Method)
No. of Poles of motors to be tested	2/4/6/8 Poles
Standard of Testing	IEC-60034-2-1
Voltage Control	0-440V Auto Transformer with Feedback control to maintain $\pm 1V$ tolerance
Speed Measurement	Optical Proximity with 1 rpm resolution
Torque Measurement	Reaction Type Sensor with $\pm 0.1\%$ FS Accuracy
Power Measurement	3-Phase Power Meter with Class 0.5 Accuracy
Measurement & Control	Labview based Computer Control, Monitoring & Efficiency Computations

The Motor test bench is used to evaluate the developed

MPA with different motor capacities. The MPA performance was compared on 5 HP and 10 HP motors with the conventional method (IEC 60034-2-1) using the test bench. The MPA was evaluated against the standards. The MPA was tested and evaluated with a 5 HP motor, whose specifications are shown in Table V.

TABLE V  
SPECIFICATION OF MUT

Details	Specifications
Capacity of MUT	5 HP, Foot Mounted
Connection	3-Phase Delta Connected
Rated Voltage	440 V
Rated Speed (Poles)	2990 rpm (2-Pole)
Full Load Current	6 A
Frequency	50 Hz



Fig. 6 View of the Motor Test Centre available at Lab

TABLE VI  
COMPARISONS OF MPA RESULTS ON 5 HP MOTOR

$V_{LL}$ (V)	$I_L$ (A)	$P_{in}$ (W)	Speed (rpm)	Torq. (Nm)	$P_{out}$ (W)	Std. Eff. (%)	MPA Eff. (%)
380	3.7	843	3013	0.52	164	19	26.52
376	3.7	965	2981	0.99	309	32	32.30
379	3.9	1143	2994	1.5	470	41	41.04
380	4	1303	2981	2.01	627	48	47.24
381	4.1	1455	2976	2.49	776	53	52.29
379	4.2	1607	2968	2.97	923	57	57.07
381	4.4	1790	2986	3.52	1100	61	61.77
380	4.6	1961	2946	4.08	1258	64	63.71
380	4.8	2113	2981	4.53	1413	67	66.33
381	4.9	2270	2953	5.01	1548	68	67.00
380	5.2	2441	2967	5.47	1699	70	69.02
380	5.3	2610	2981	5.97	1863	71	70.60
380	5.6	2802	2966	6.56	2036	73	71.59
380	5.8	2959	2922	7.04	2153	73	72.44
380	6	3141	2962	7.51	2328	74	73.19
380	6.3	3318	2949	8.01	2472	75	74.11
380	6.5	3466	2917	8.5	2595	75	74.49

TABLE VII  
ERROR SUMMARIES ON 5 HP MOTOR

Description	%Error
Minimum Error (excluding error at no-load)	-1.26%
Maximum Error	2.49%
Average Error	0.78%
Std. Deviation	1.01%

Fig. 7 shows the view of the Motor Test Bed-1 installed with 5 HP MUT. The MPA was connected to the MUT by connecting the voltage i/p of the MPA to the motor terminals and clamp-on current sensors are clamped to motor cables. Separate speed sensor was installed near the shaft and connected to the MPA. The load on the motor was varied by varying the excitation voltage applied to the eddy current dynamometer. The load was varied from no-load to 120% of full load. The operating efficiency of the motor under test obtained from the conventional method (IEEE 112-B) and the MPA are tabulated as shown in Table VI.

A graph was plotted to study the comparison of performance as shown in Fig. 8. From the graph, it is inferred that the operating efficiencies obtained from the conventional

method and MPA are almost coinciding with each other except under no-load conditions. This may be due to the error in the CTs in the lower range of current. The error obtained from the study on a 5 HP motor is summarised in Table VII.

The MPA was tested and evaluated with another motor having a capacity of 10 HP, and the specification of MUT is shown in Table VIII.



Fig. 7 View of the Motor Test Bed - 1 with 5 HP Motor installed

TABLE VIII  
SPECIFICATION OF MUT

Details	Specifications
Capacity of MUT	10 HP, Flange Mounted
Connection	3-Phase Delta Connected
Rated Voltage	415 V
Rated Speed (Poles)	1450 rpm (4-Pole)
Full Load Current	14.6 A
Frequency	50 Hz

Fig. 9 shows the view of the Motor Test Bed-2 installed with 10 HP MUT. The MPA was connected to the system as prescribed earlier and the load on the motor was varied. The operating efficiency of the motor under test obtained from the conventional method (IEEE 112-B) and the MPA are

tabulated as shown in Table IX.

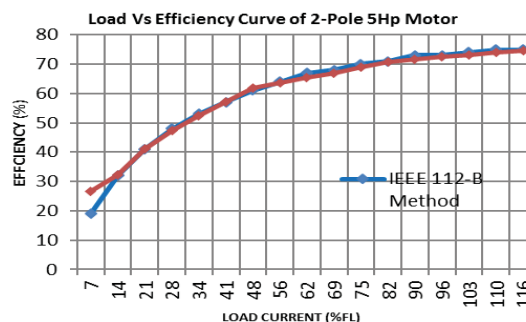

Fig. 8 Comparison of the Performance on 5 HP Motor

TABLE IX  
COMPARISONS OF MPA RESULTS ON 10 HP MOTOR

V <sub>LL</sub> (V)	I <sub>L</sub> (A)	P <sub>in</sub> (W)	Speed (rpm)	Torq. (Nm)	P <sub>out</sub> (W)	Std Eff. (%)	MPA Eff. (%)
379	7.0	1239	1487	3.72	579	47	48.22
381	7.2	1710	1485	6.66	1035	61	62.51
380	10.2	4846	1468	22.15	3403	70	71.04
378	14.9	8140	1451	41.33	6277	77	77.24
381	18.2	10355	1436	53.46	8035	78	78.29

TABLE X  
ERROR SUMMARIES ON 10 HP MOTOR

Description	%Error
Minimum Error (excluding error at no-load)	-2.60%
Maximum Error	-0.31%
Average Error	-1.45%
Std. Deviation	1.11%

The developed system was also field-trialed with a 15HP, 3-phase induction motor used in the cooling tower applications. Fig. 11 shows the snapshots taken during testing of the motor with the developed MPA. The screenshots of the MPA system during operation are shown in Fig. 12.

## VI. CONCLUSION

A portable handy MPA Tool suitable for conducting motor performance study on-line and in-situ was developed successfully and evaluated. The results obtained from the conventional IEEE 112-B method and the MPA are very much acceptable and satisfactory. The developed system was also field-trialed at many industries that include engineering industries, cement industries, water supply schemes, and universities. The results obtained during the field-trials are very satisfactory for the industries.



Fig. 9 View of the Motor Test Bed – 2 with 10 HP Motor

A graph was plotted to study the comparison of performance as shown in Fig. 10. From the graph, it is inferred that the operating efficiencies obtained from the conventional method and the MPA are almost coinciding with each other. The error obtained from the study on a 10 HP motor is summarised in Table X.

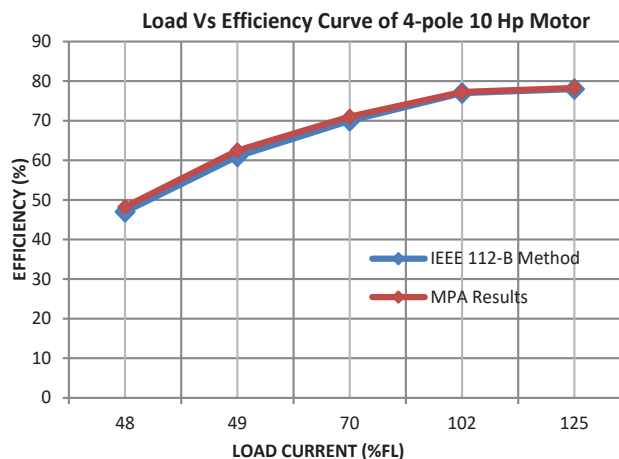

Fig. 10 Comparison of the Performance on 10 HP Motor



Fig. 11 Snapshots during field-trial of the MPA

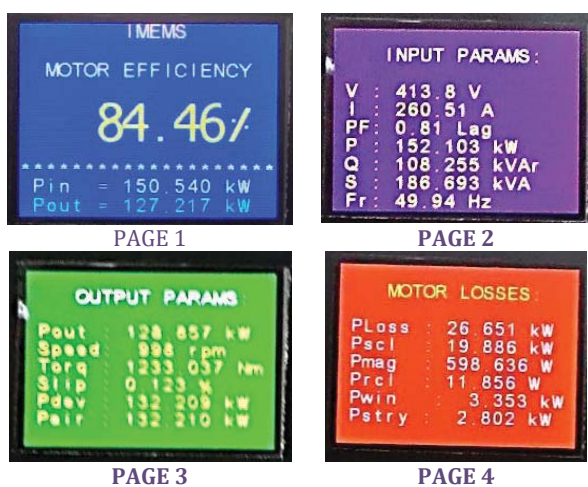

Fig. 12 Screenshots of the MPA Display Pages

#### ACKNOWLEDGMENT

We sincerely thank Prof. R. K. Sinha, Director, CSIR-CSIO Chandigarh for allowing us to undertake such a challenging work and his unstinted support. We acknowledge our industrial partner M/s BETA Technologies (I) Private Limited, Coimbatore. We also acknowledge the engineers at BHEL, Trichy, RAMCO Cements-Jayanthipuram, Metro Water-Chennai and Prof. B. Umamaheswari, Anna University.

#### REFERENCES

- [1] World Energy Resources, 2013 Survey, World Energy Council
- [2] "Energy Statistics - 2015", Ministry of Statistics and Programme Implementation, Government of India.
- [3] Paul Waide and Conrad U. Brunner, "Energy-Efficiency Policy Opportunities for Electric Motor-Driven Systems", International Energy Agency (IEA), Energy Efficiency Series 2011.
- [4] Tobias Fleiter and Wolfgang Eichhammer, "Energy efficiency in electric motor systems: Technology, saving potentials and policy options for developing countries", Development Policy, Statistics and Research Branch Working Paper 11/2011, United Nations Industrial Development Organization, Vienna, 2012.
- [5] Bruno De Wachter, "Application Note - Electric Motor Asset Management", European Copper Institute, Publication No: Cu0104, Issue: 02, August 2011.
- [6] Yang, M., "Energy efficiency policy impact in India: case study of investment in industrial energy efficiency. In: Energy Policy, 34 (17), 2006, pp. 3104-3114.

- [7] J. S. Hsu, J. D. Kueck, M. Olszewski, D. A. Casada, P. J. Otaduy, and L. M. Tolbert, "Comparison of Induction Motor Field Efficiency Evaluation Methods", IEEE Transaction on Industry Applications, Vol. 34, No. 1, January/February 1998, pp. 117-125.
- [8] "IEEE Standard Test Procedure for Polyphase Induction Motors and Generators", IEEE 112 Standards, 2004.
- [9] "Efficiency Test for Induction Motors with Agilent USB Data Acquisition (DAQ) Device Application Note", Agilent Technologies.
- [10] G. S. Ayyappan, Kota Srinivas, Chenthamarai Selvam, Meenalochani Chander, "Genetic algorithm based on-site Induction Motor Efficiency Monitoring Systems", Journal of Instrument Society of India, Vol. 39, No. 4, pp. 280-282, December 2009.
- [11] T. Phumiphak and C. Chat-Uthai, "Estimation of Induction Motor Parameters Based on Field Test Coupled with Genetic Algorithm", Proceedings of 2002 International Conference on Power System Technology, PowerCon 2002, vol. 2, Kunming, China, Oct. 2002, pp. 1199-1203.
- [12] Jafar Mohammadi, Mohammad B.B. Sharifian, Khalil Banan, "Induction Motor Efficiency Estimation using Genetic Algorithm", Proceedings of World Academy Of Science, Engineering and Technology, January 2005, Volume 3, ISSN 1307-6884.
- [13] Ivan Kostov, Vasil Spasov, Vania Rangelova, "Application of Genetic Algorithms for Determining the Parameters of Induction Motors", ISSN 1330-3651, Technical Gazette 16, 2 (2009), 49-53.
- [14] "Guide for the use of Electric Motor Testing Methods Based on IEC 60034-2-1", May 2011, Version 1.1, Electric Motor Systems, Annex (EMSA) Task C - Testing Centres.



**Ayyappan. G.S** born in Pattiveeranpatty, Dindigul Dist., TamilNadu, India on the 4<sup>th</sup> June 1972. He did his schooling in Pattiveeranpatty and Diploma in electrical & electronics engineering from P.A.C. Ramasamy Rajas Polytechnic, Rajapalayam, Tamilnadu, India during 1987-90 and stood State first rank. Did his Under-graduation in electrical & electronics engineering from Anna university, Chennai, India during 1998-2001 and recipient of university gold medal and general proficiency award conferred by the University; Later he did M. Tech., in electronics & control engineering from Sathayabama University, Chennai, Tamilnadu, India during 2007-09 and received the university gold medal. At present, he is pursuing dissertation in Life Cycle Assessment of Induction Motors on continuous operations from AcSIR-CECRI, Karaikudi, Tamilnadu, Chennai.

He started his profession as Junior Technical Assistant at CSIR-Central Scientific Instruments Organisation (CSIO) during 1990 and raised to Senior Scientist. Also, he is contributing in academic field as Assistant Professor at AcSIR-SERC-Renewable Energy program. Recently, he has completed a DST funded project titled "On-line, on-site and in-situ Induction Motor Efficiency Monitoring System" and developed the technology called Induction Motor Efficiency Monitoring System (IMEMS). The developed technology is transferred to two Indian firms for its commercialization. At present, he is heading a DST funded project titled "In-situ and non-intrusive Motor Stehoscope for monitoring the health of Induction Motor" and "Life Cycle Assessment of induction motors on continuous operations". He holds three international patent rights and one Indian Patent in the field of Energy Monitoring and Control Systems. He has transferred more than 10 technologies to the industries for commercialisation. He has about 10 research papers published in the international & national journals in the area of energy management instrumentations and signal processing. He presented more than 30 papers in National & International Conferences, Symposiums and Workshops. He has delivered about 200 lectures to the students community of Engineering and Arts & Science Colleges in India. He bagged two National level best paper awards conferred by ISOI, Bengaluru, India. His area of interests are embedded solutions, metering & industrial networking in the area of energy management instrumentation and achieving energy efficiency through motors and pumps in industries.

Mr. Ayyappan has many academic awards, distinctions, and scholarships to his credit including the Raman Research Fellowship award for the year 2011-12 instituted by CSIR. Indiragandhi Sadrhavan Gold Medal Award for the outstanding individual contribution in the field of Engineering & Research during 2014 conferred by GEPR, New Delhi and Lifetime Achiever Award from Sree Dharmasaastha Trust, Chennai. He visited Lawrence Berkeley National Laboratory (LBNL), Berkeley, California, USA for the period of 4-months under deputation. He has 25 plus years of mammoth splendid experience in R & D in the fields of scanning tunneling microscopy, process

control instrumentation, biomedical instrumentations, energy management instrumentation and 5 years in pedagogy.



**Prof. Srinivas Kota**, born at Gundur, India on 3rd November 1960. He obtained his M.Sc (Tech) from Regional Engineering College, Warangal, India in 1983 and M.S degree in electronics & control engineering branch from BITS, Pilani during the year 1994.

He joined as Scientist-B at CSIR-Central Electronics Engineering Research Laboratory (CSIR-CEERI) in 1984 presently he is Chief Scientist at CSIR-Central Scientific Instruments Organisation (CSIO) Chennai Centre & heading the Chennai Centre as Scientist-in-charge. He is also a faculty in Academy of Scientific & Innovative Research (AcSIR), Renewable Energy course as Professor in India. He got 32 years of R&D experience and worked in various projects in the level of team members and leaders in field of energy management instrumentation, process control instrumentation, bio-sensor based instrumentation for health etc. He has got 11 national & international research papers published and one patent in his credit. He has transferred 7 technologies to the industries. He has presented more than 50 papers in the conferences and published about 5 reports. His areas of expertise are embedded systems & electronics in the field of energy management instrumentation and process control instrumentation.

Prof. Srinivas has got more awards in his credits; DAAD fellowship award and deputed to The Federal Army University, Munich, Germany for the period of two years from 1992, NRDC (National Research & Development Centre) award as a team member for pH control system 1990, WIPO Award and CSIR technology Shield for 1992.



**Jaffer R.C. Sheriff**, born in Chennai on 19<sup>th</sup> September 1988. He has got diploma in electronics and communication engineering from Government Polytechnic College, Tiruchirappalli, India and obtained First Class with Honors in the year 2007, bachelor degree in electronics and communication engineering from Bharathidasan Institute of

Technology, Bharathidasan University, Tiruchirappalli, India in Aug 2010 and master degree in embedded system technologies from College of Engineering Guindy Campus, Anna University, Chennai, India in May 2012.

He worked in the position of Junior Research Fellow, Senior Research Fellow at CSIR labs and presently he is working as Firmware Engineer at Danfoss Industries Private Limited, Chennai in the field of research & development. He is well versed in Embedded C, C++, Hardware Design and Simulation. He presented one paper in the international conference and two papers in the national conferences.

Mr. Jaffer has been awarded with CSIR Junior & Senior Research Fellowships and Certificate of Excellency Award from Government Polytechnic College, Tiruchirappalli, India during April 2007. He also received first prize for his paper presented in national level professional conference. He has the expertise in the field of biomedical instrumentation, energy instrumentation etc.



**Prakash Chandra Joshua C.**, born in Chennai on 25th April 1990. His school education is from Chennai, India. He obtained his bachelor degree in electrical and electronics engineering from Madha Engineering College, Chennai, India in 2011 with distinction and master degree in power systems engineering from College of Engineering, Guindy campus, Anna University, Chennai, India in 2014.

Mr. Prakash started his career as Project Assistant at CSIR-CSIO Chennai Centre, Taramani, Chennai, India and presently he is working as Project Scientist at National Institute of Ocean Technology, Chennai, India since 12th January 2015. He is involved in the implementation of signal processing techniques & LabVIEW coding. His areas of interests are Control Systems, Power Systems, Microprocessor & Microcontroller, AC & DC Machines and Electronic Devices & Circuits.