

Computer Aided Assembly Attributes Retrieval Methods for Automated Assembly Sequence Generation

M. V. A. Raju Bahubalendruni, Bibhuti Bhusan Biswal, B. B. V. L. Deepak

Abstract—Achieving an appropriate assembly sequence needs deep verification for its physical feasibility. For this purpose, industrial engineers use several assembly predicates; namely, liaison, geometric feasibility, stability and mechanical feasibility. However, testing an assembly sequence for these predicates requires huge assembly information. Extracting such assembly information from an assembled product is a time consuming and highly skillful task with complex reasoning methods. In this paper, computer aided methods are proposed to extract all the necessary assembly information from computer aided design (CAD) environment in order to perform the assembly sequence planning efficiently. These methods use preliminary capabilities of three-dimensional solid modelling and assembly modelling methods used in CAD software considering equilibrium laws of physical bodies.

Keywords—Assembly automation, assembly attributes, assembly sequence generation, computer aided design.

I. INTRODUCTION

OVER the past four decades, industrial engineers are striving to solve assembly sequence planning problem efficiently with the continuous technology advancements in order to reduce the overall assembly cost. In early 90s, assembly sequence planning problem solving methods were developed aiming to generate single or numerous valid assembly sequences [1]-[3]. These methods are highly time consuming and need extremely skilled user's intervention to answer assembly relational queries [4]-[6]. Bourjault [1] and De Fazio's liaison based precedence relation method [3] and Homem de Mello's assembly cut-set method [2] belong to this category.

Owing to possibility of several feasible assembly sequences for a product, researcher's attention is moved towards achieving optimal assembly sequence in less computational time. Researchers used various artificial intelligence (AI) techniques like Genetic algorithms, Simulated annealing, Neural networks, Particle Swarm Optimization, Harmonious colony-decision algorithm, Ant colony algorithm, Hybrid algorithms, and many others to achieve optimal solution efficiently [7]-[11]. Assembly product information is the

primary parameter for these AI based assembly sequence planning problems.

Each assembly sequence generated during assembly sequence planning must be tested for all necessary assembly predicates. However, the manual mode of extracting the assembly information is highly time consuming and skillful task for any product with large number of parts. Many studies have been done to extract these data from CAD based products using basic features and application programming interface (API) compatibility [12], [13]. Liaison matrix and assembly connection matrix extraction from CAD models were discussed by researchers using assembly contact information [14]-[16]. Geometrical feasibility test can be done by using part mating features and assembly interference matrices. Extraction of part mating features from different CAD data exchange formats were reported [17]-[19]. Collision detection algorithms are best used to generate the assembly interference matrices [20]. Gu and Yan [21] and Mok et al. [22] made attempts to generate assembly interference matrices from different formats of CAD models. Bahubalendruni and Biswal attempted to find economic feasible assembly direction using bounding box coordinates and collision detection method [23], [24]. Although most of the researchers considered basic assembly predicates, stability and mechanical feasibility predicate were ignored due to the complex procedure of extraction [25]-[28]. The influence of ignoring these assembly predicates greatly impacts search space, computational time and quality of solution [29]. In the current research article, methods to extract all the assembly attributes required to perform optimal assembly sequences from CAD database are clearly illustrated.

II. ASSEMBLY CONTACT INFORMATION EXTRACTION

An appending part must exhibit at least one contact with respect to any other part in the existent assembly subset. Graphical representation of assembly contact relations proposed by Bourjault [1] can be effectively used for this purpose. Dini further simplified the representation of assembly contact information in matrix mode for ease of accessibility. General method to extract and store liaison matrix in a two-dimensional array through assembly contact analysis from an assembled CAD product is represented in Fig. 1.

The presented method is implemented on assembly shown in Fig. 2, and the resulted liaison matrix is represented below.

B. B. Biswal is with the National Institute of Technology, Rourkela, Odisha -769008, India (corresponding author, phone: +91 9437158476; e-mail: bbbiswal@nitrkl.ac.in).

M. V. A. Raju Bahubalendruni, is with GMR Institute of Technology, Rajam India. (e-mail: bahubalendruni@gmail.com).

B. B. V. L. Deepak is with the National Institute of Technology, Rourkela, Odisha -769008, India (e-mail: bbv@nitrkl.ac.in).

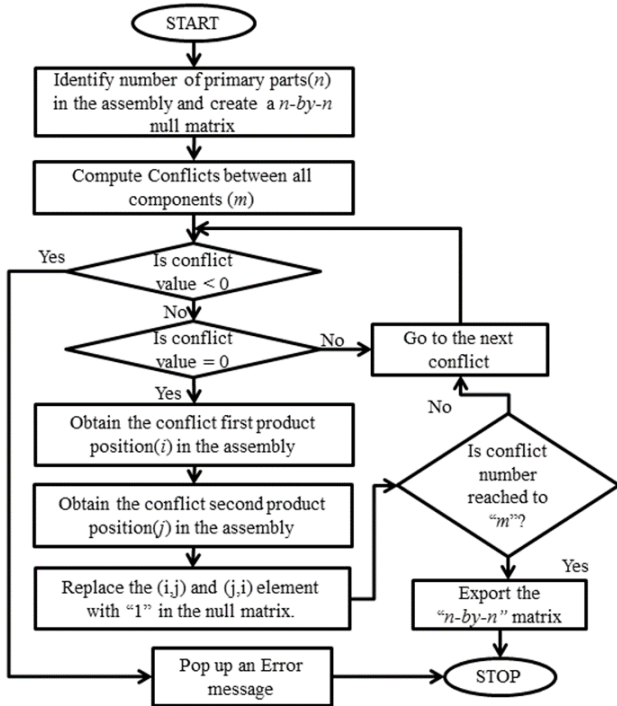

Fig. 1 Mechanism to extract liaison matrix from 3D CAD environment

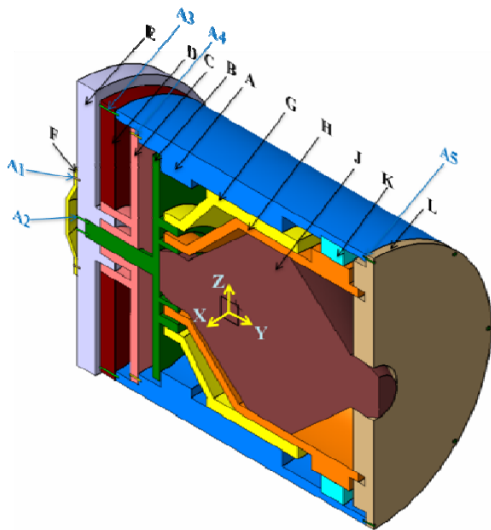

Fig. 2 Transmission assembly (De Fazio and Whitney [3])

	A	B	C	D	E	F	G	H	J	K	L
A	0	0	1	1	0	0	1	0	0	1	1
B	0	0	1	0	1	0	1	1	1	0	0
C	1	1	0	1	1	0	0	0	0	0	0
D	1	0	1	0	0	0	0	0	0	0	0
E	0	1	1	0	0	1	0	0	0	0	0
F	0	0	0	0	1	0	0	0	0	0	0
G	1	1	0	0	0	0	0	1	0	0	0
H	0	1	0	0	0	0	1	0	1	1	1
J	0	1	0	0	0	0	0	1	0	0	1
K	1	0	0	0	0	0	0	1	0	0	0
L	1	0	0	0	0	0	0	1	1	0	0

III. GEOMETRICAL FEASIBILITY INFORMATION EXTRACTION

In order to retrieve the assembly feasibility information, collision detection methods should be used efficiently considering part geometrical boundaries. Each part axis-aligned bounding box coordinates are considered to represent the geometric boundaries for the collision free part trajectories. Fig. 3 represents lower corner and upper corner of bounding box coordinates of a primary part (Part-C).

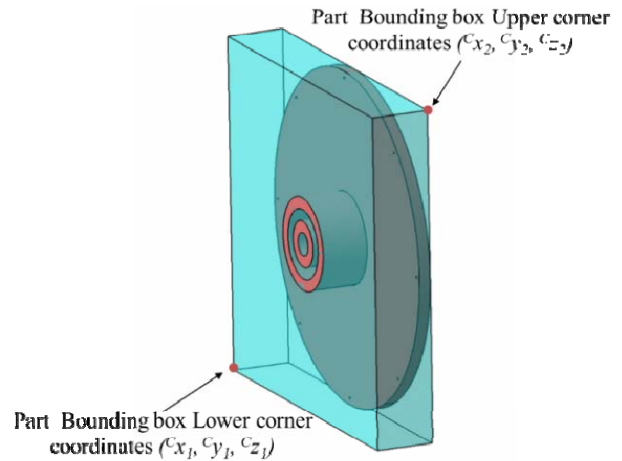

Fig. 3 Part-C Bounding box representation

There exist three different instances for any two parts (part-i and part-j). Instance-1: If the lower limit of part-i is more than the upper limit of part-j, and hence part-j does not interfere, while part-i is disassembled along the specified positive direction. These instances must be ignored from the feasibility testing by reading bounding box coordinates of the parts and unit value has been assigned to the directed interference matrix element.

Instance-2: The lower limit of part-i is less than the upper limit of part-j, and hence, part-j may interfere, while part-i is disassembling along the specified positive direction. Difference between the upper limit of part-j to the lower limit of part-i will be considered as distance to be travelled by part-i without any collision. These instances must be considered for the feasibility testing. Instance-3: If the upper limit of part-i is less than the lower limit of part-j, then part-i will be moved towards part-j till both values are matched, and Instance-3 will be turned out to instance-2 category. All the three possible instances are shown in Fig. 4.

An algorithm to extract interference matrix along a positive direction (y+) is shown in Fig. 5. The method uses bounding box coordinates of part in combination with assembly contact analysis. Most of the mechanical codes have capabilities to translate the parts in 3D-space and perform assembly contact analysis. The proposed method can be similarly applied for all other directions (X-, X+, Y-, Z-, Z+).

The method is implemented on an assembly shown in Fig. 2, and the resulted interference matrix is given below. Element value "1" means that the part indicated in the column is feasible to dis-assemble along the specified direction in the presence of part indicated in row.

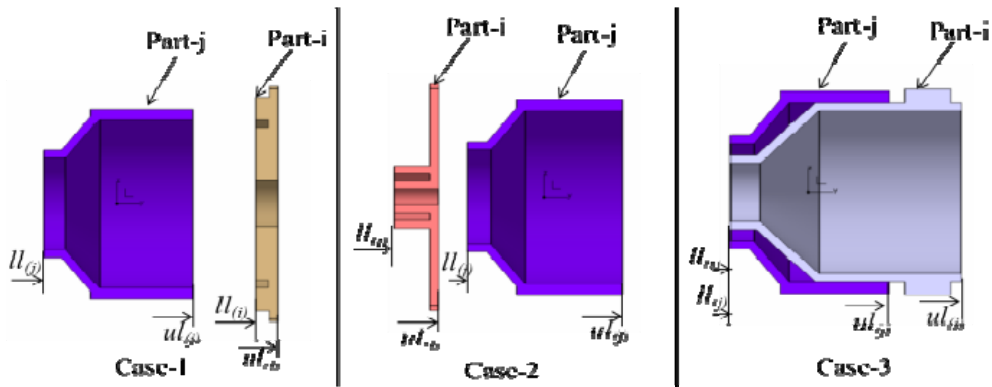

Fig. 4 Feasibility testing instances between pair of parts

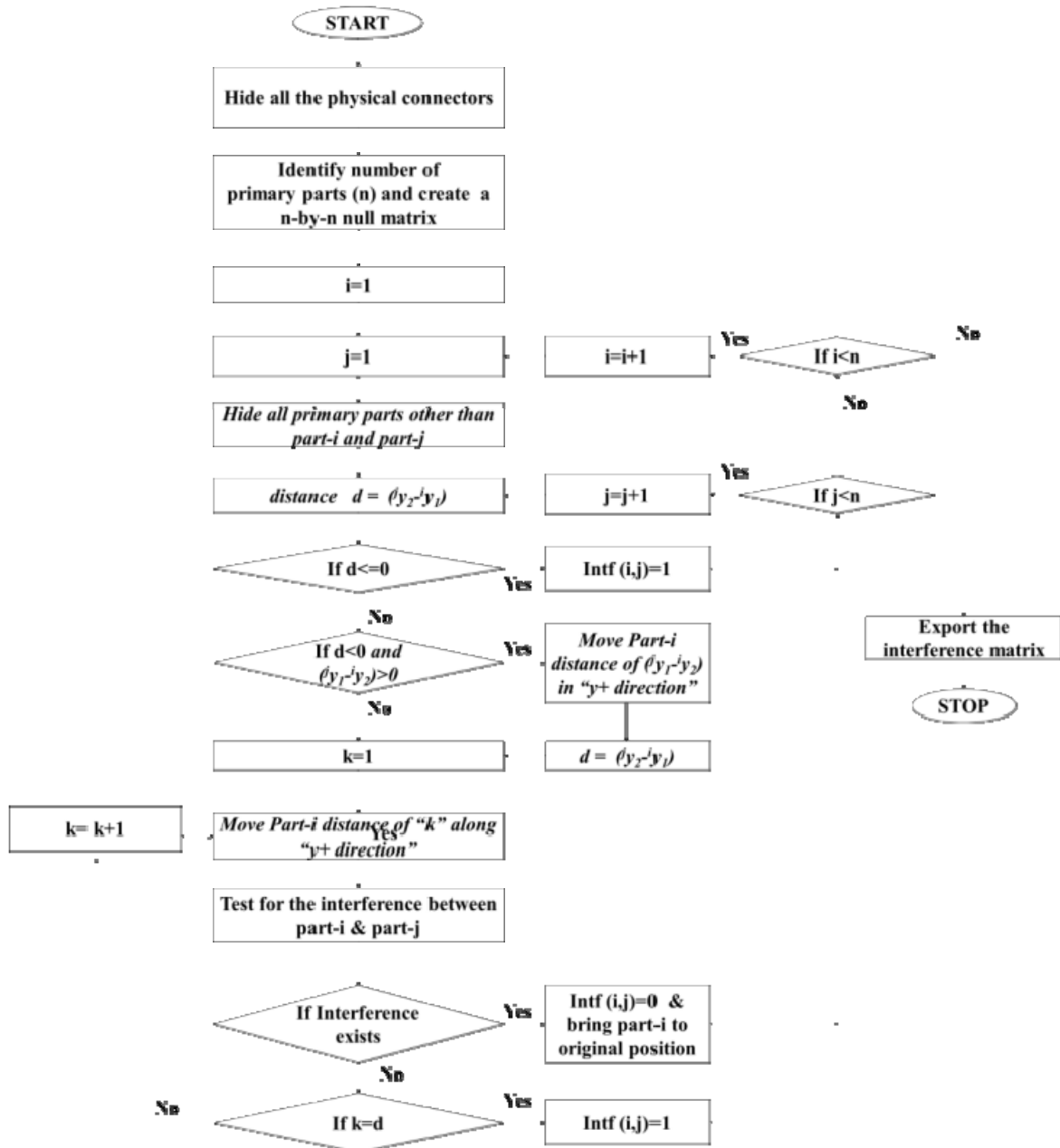

Fig. 5 Flow chart to extract Interference matrix along "y+" direction

(Y+)	A	B	C	D	E	F	G	H	J	K	L
A	0	1	1	1	1	1	0	0	1	0	0
B	0	0	1	1	1	1	0	0	0	0	0
C	0	0	0	1	1	1	0	0	0	0	0
D	0	0	0	0	1	1	0	0	0	0	0
E	0	0	0	0	0	1	0	0	0	0	0
F	1	0	0	0	0	0	0	0	0	1	0
G	1	1	1	1	1	1	0	0	0	1	0
H	1	1	1	1	1	1	1	0	0	1	0
J	1	1	1	1	1	1	1	1	0	1	0
K	1	1	1	1	1	1	1	1	1	0	0
L	1	1	1	1	1	1	1	1	1	1	0

IV. STABILITY INFORMATION EXTRACTION

An assembly sequence is said to be stable, when each of the parts in the assembly maintain its position with respect to the other parts at all stages of assembly operations. Representation of stability using stable relations between each pair of parts is proposed by Smith et al. [30] and later modified by Bahubalendruni et al. [31]. Smith proposed representation of assembly connections in matrix format; the connections are categorized into two classes; hard and soft. When two parts are connected by physical connectors, the connection is considered as hard and if two components just maintain their position by surface contact without any physical connection is referred to be soft connection.

In the current research, stability is broadly classified as partial and permanent stability. A component is treated as partially stable when it does not lose its contact with all mating parts due to application of natural gravitational force. However, the assembly is oriented, and the parts may lose its contacts. Partial stability of part is more considered in sequential assembly planning process. Further classification of permanent stability is made by the usage of external attachments, and surface features. A component is treated as permanently stable, when it is connected through its surface features or by external connectors in order to maintain all its contacts with mating parts irrespective of the orientation. Permanent stability is an essential criterion for sub-assembly detection.

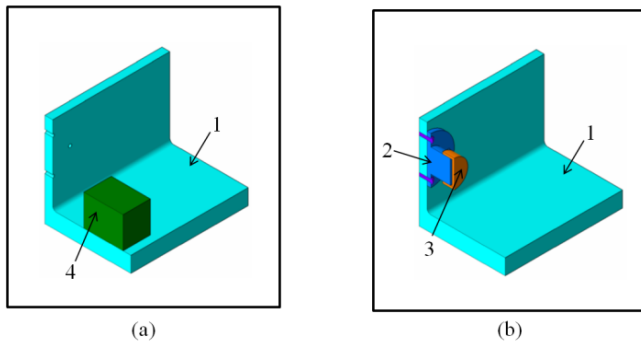

Fig. 6 Assembly sub-sets to demonstrate types of stability

Assembly subset (part 1-4) shown in Fig. 6 (a) is partially stable in which part-4 do not maintain its contact with respect

to other mating part-1 when the assembly sub-set is rotated. Fig. 6 (b) represents a permanently stable assembly sub-set (1-2-3) which can be treated as a sub-assembly for the further level of assembly possess. The connection data for an assembled product can be represented by a “nxn” matrix for a product with “n” number of primary parts. Element [i][j] of the connection matrix represents how part-i is connected with part-j. Element values 0, 1, 2, and 3 successively represent no stability, partial stability, permanent stability due to part features and permanent stability by external physical connectors.

A. Partial Stability Matrix Extraction

Laws of equilibrium and stability of physical objects state: If a part cannot be rotated about an axis passing through its center of gravity parallel to the ground (XY- Plane). Fig. 7 briefs the possible instance of stability due to the resulted interferences while rotating the part in both clockwise and counter clockwise orientations.

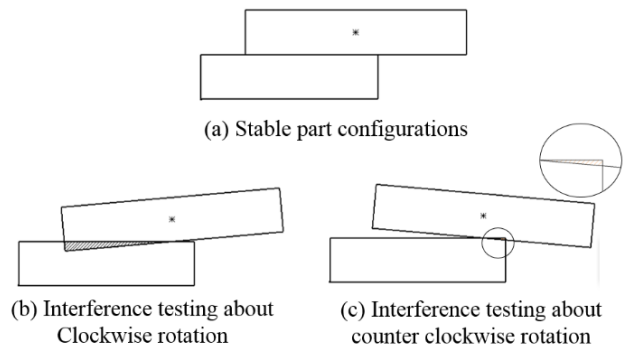

Fig. 7 Partially stable assembly sets

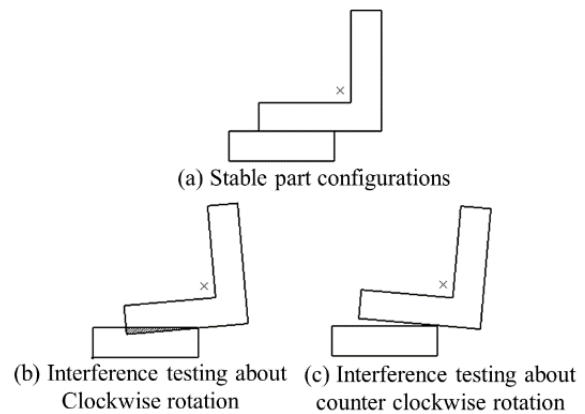

Fig. 8 Partially un-stable assembly sets

The possibility of instability due to clearance between the parts while rotated in counter clockwise orientation illustrated in Fig. 8. The contribution of liaison matrix and interference matrix about “z-” orientation will reduce the further efforts of partial stability matrix extraction.

Partial stability has to be checked for the pair of parts for which liaison matrix element and the interference matrix element values must be “1” and “0”, respectively i.e indicating that the pair of parts are in contact and part-i (represented in

row) cannot be disassembled along “z-” direction in the presence of part-j (represented in column). An algorithm to extract partial stability matrix is presented in the flow chart shown in Fig. 9.

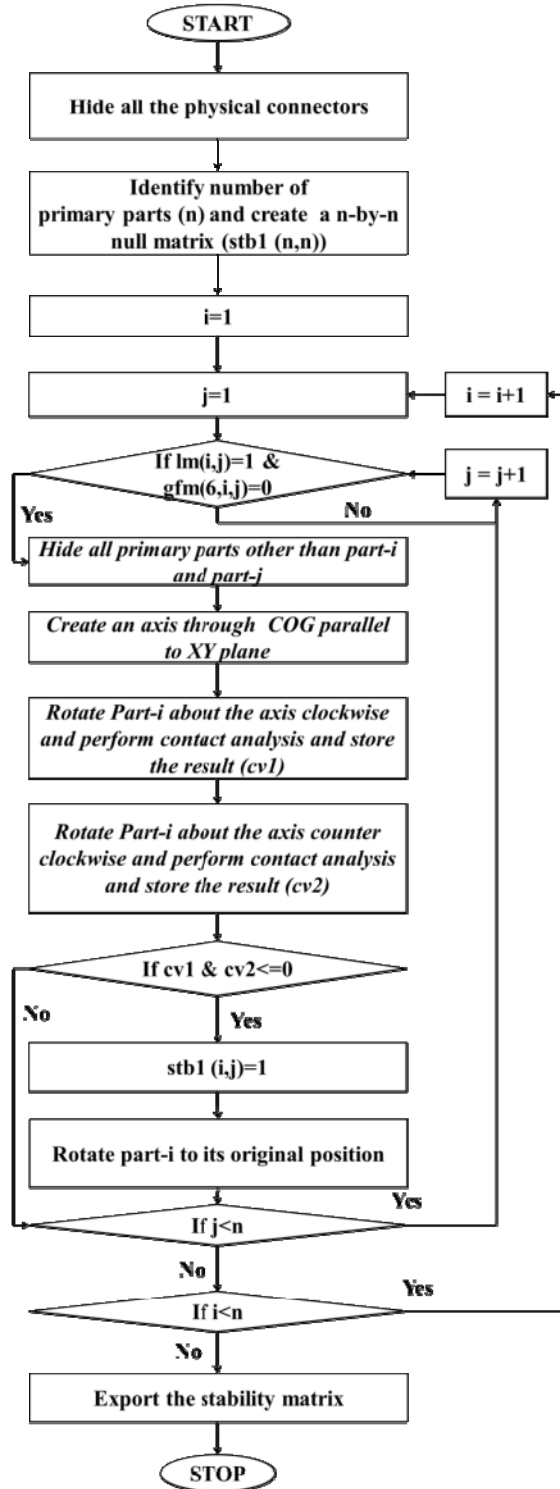

Fig. 9 Algorithm to extract partial stability matrix

The method is implemented on an assembly shown in Fig. 2, and the resulted partial stability matrix is given below.

	A	B	C	D	E	F	G	H	J	K	L
A	0	0	1	0	0	0	1	0	0	1	1
B	0	0	1	0	1	0	1	1	1	0	0
C	1	1	0	1	1	0	0	0	0	0	0
D	0	0	1	0	0	0	0	0	0	0	0
E	0	1	1	0	0	0	0	0	0	0	0
F	0	0	0	0	0	0	0	0	0	0	0
G	1	1	0	0	0	0	0	1	0	0	0
H	0	1	0	0	0	0	1	0	1	1	1
J	0	1	0	0	0	0	0	1	0	0	1
K	1	0	0	0	0	0	0	1	0	0	0
L	1	0	0	0	0	0	0	1	1	0	0

B. Permanent Stability Matrix Extraction (Due to Mating Features)

The part surface feature recognition is mainly dependent on the modelling methodology and the software interface compatibility to retrieve the information. Most of the advanced CAD codes (CATIA V5, SolidWorks, Pro E, Unigraphics, etc.,) offer flexibility to users in feature modelling and data extraction. Parts connected by their surface features such as threading, generally possess only one degree of freedom for assembly or disassembly operation. Hence, geometric feasibility matrices and liaison matrix data further minimize the complexity and computation time in retrieving the permanent stability information due to mating features. The method involves in extracting the part feature information (for example internal thread with a defined diameter and pitch on a lateral face) and tests for counter data on its mating part (External threading with same diameter and pitch) at the mating surface. A mechanism to extract permanent stability matrix is presented through a flowchart in Fig. 10.

Macro is written in VB script to get the permanent stable pair of parts, and permanent stability is indicated by “2” in the stability matrix. An assembly subset with four parts and four attachments cutaway shown in Fig. 11 is considered to demonstrate the permanent stability due to the part features.

For the assembly shown in Fig. 11, part-2 and part-3 are connected by means of surface threading and exhibits permanent stability. The resulted assembly stability matrix is given below.

C. Permanent Stability Matrix Extraction (Due to Physical Connectors)

Extraction of permanent stability matrix involved in identifying the connectors in the assembly model by their nomenclature and obtaining the pair of primary parts joined by the connector. Assembly contact analysis for a connector against all primary parts results pair of part those were connected by it, iterating the process for each connector resulting in permanent stability matrix. A computer aided method to extract permanent stability matrix is presented in Fig. 12 through flow chart.

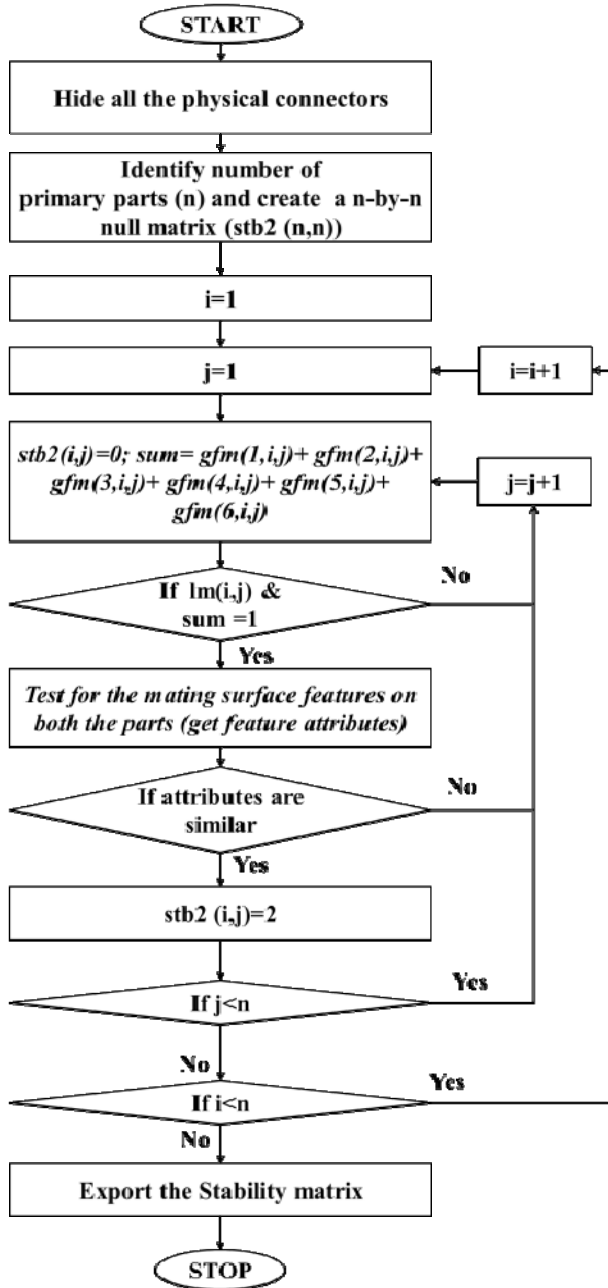

Fig. 10 Permanent stability matrix extraction method

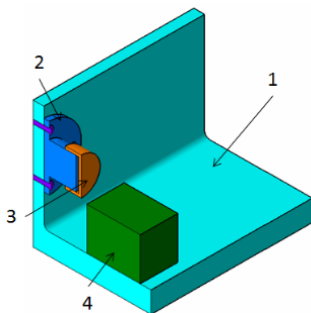

Fig. 11 Cutaway of 4-Part Assembly subset with 4 attachments

	1	2	3	4
1	0	0	0	0
2	0	0	2	0
3	0	2	0	0
4	0	0	0	0

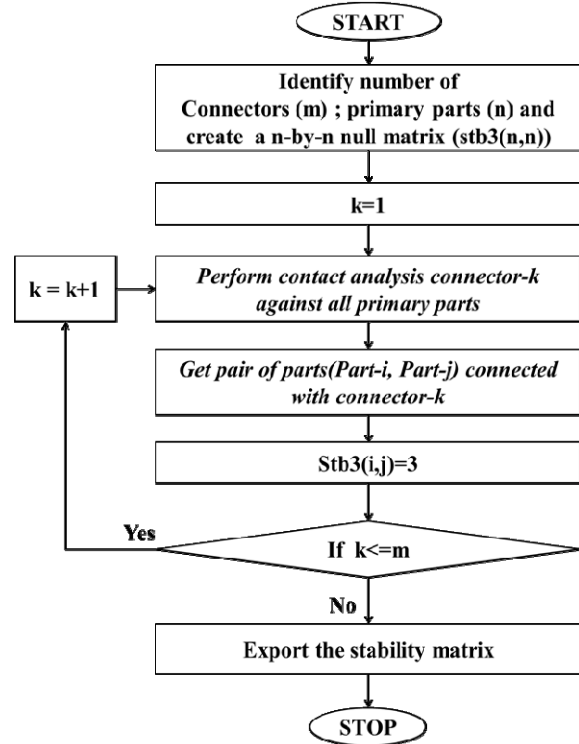

Fig. 12 Cutaway of four-part assembly subset with four attachments

Permanent stability matrix due to external connectors is extracted through a program written in VB script to interface with CATIA v5 environment. The resulted matrix is given below for the assembled product which is shown in Fig. 2. Permanent Stability matrix for transmission assembly due to external connectors is presented as:

	A	B	C	D	E	F	G	H	J	K	L
A	0	0	3	3	0	0	0	0	0	0	3
B	0	0	0	0	3	0	0	0	0	0	0
C	3	0	0	0	0	0	0	0	0	0	0
D	3	0	0	0	0	0	0	0	0	0	0
E	0	3	0	0	0	3	0	0	0	0	0
F	0	0	0	0	3	0	0	0	0	0	0
G	0	0	0	0	0	0	0	0	0	0	0
H	0	0	0	0	0	0	0	0	0	0	0
J	0	0	0	0	0	0	0	0	0	0	0
K	0	0	0	0	0	0	0	0	0	0	0
L	3	0	0	0	0	0	0	0	0	0	0

The combined stability matrix can be obtained by choosing the highest element value from partial and permanent stability matrices due to the possibility of conversion from partial

stability condition to permanent stability condition due to external connectors. Combined stability matrix for transmission assembly shown in Fig. 2 is given as:

	A	B	C	D	E	F	G	H	J	K	L
A	0	0	3	3	0	0	1	0	0	1	3
B	0	0	1	0	3	0	1	1	1	0	0
C	3	1	0	1	1	0	0	0	0	0	0
D	3	0	1	0	0	0	0	0	0	0	0
E	0	3	1	0	0	3	0	0	0	0	0
F	0	0	0	0	3	0	0	0	0	0	0
G	1	1	0	0	0	0	0	1	0	0	0
H	0	1	0	0	0	0	1	0	1	1	1
J	0	1	0	0	0	0	0	1	0	0	1
K	1	0	0	0	0	0	0	1	0	0	0
L	3	0	0	0	0	0	0	1	1	0	0

V. MECHANICAL FEASIBILITY INFORMATION EXTRACTION

In order to test the mechanical feasibility, firstly number of connectors must be identified from the stability matrix. By using the stability matrix, pair of parts with element value “3” must be acknowledged and contact analysis should be done for both the parts against all the physical connectors [32]. The common connectors are grouped into one set. While placing set of connectors, any part in the existed assembly other than those pair of parts can offer collision. Each connector will be tested for the geometric feasibility in the presence of other primary parts by using their bound box coordinates. Fig. 13 presents the flowchart to retrieve mechanical feasibility matrix using stability matrix data.

Mechanical feasibility matrix extraction method is presented in flow chart shown in Fig. 13, and a program is written in VB script to extract the mechanical feasibility matrix for the transmission assembly which is shown in Fig. 14.

VI. MECHANICAL FEASIBILITY INFORMATION EXTRACTION

In order to extract the assembly attribute information from CAD software through the above stated mechanisms, the software must be equipped with the basic part design and assembly design/representation module with several capabilities. Table I lists the basic requirements and their purpose in assembly attribute extraction. Table II lists the most used mechanical design software and their compatibility to extract the assembly attribute information.

VII. CONCLUSIONS

Detailed methods and computer aid to extract assembly attributes such as liaison matrix, geometrical feasibility matrices, mechanical feasibility matrices, and partial and permanent stability matrices are clearly illustrated with the example products. The proposed automated methods considering the laws of physical equilibrium along with the basic capabilities of CAD codes to retrieve assembly attributes

are discussed. These methods are proven in extracting assembly attribute information without any skilled user-intervention. These methods greatly reduce the human errors and ease the process of generation assembly sequence plans. The captured assembly information is more precise and accurate; hence, the data can be directly used for the automated assembly sequence generation problems without any efforts.

TABLE I
BASIC REQUIREMENT OF CAD CODES FOR ASSEMBLY ATTRIBUTE EXTRACTION

S. No.	Assembly Attributes	Basic requirements of CAD software	Purpose
1	Liaison Matrix	Visualization filters Assembly Clash check	To hide/unhide connectors To detect part contacts
2	Bounding Box Coordinates	Stock material measurement (or). STL conversion capability Part transformations	To detect distances between parts along all principal axes (For interference checking) Part trajectories
3	Interference matrices	Assembly Clash check Visualization filters Inertia Properties	Collision detection To hide/unhide connectors and primary parts COG detection
4	Partial Stability matrix	3D-Rotation Assembly Clash check	Stability check To detect part contacts
5	Permanent Stability matrix (Surface features)	Assembly feature's properties recognition	To detect similar features at contact faces.
6	Permanent Stability matrix (External connectors)	Part detection by nomenclature Assembly Clash check	Connectors identification To detect part contacts
7	Mechanical feasibility Matrix	Part transformations Assembly Clash check Visualization filters	Part trajectories Collision detection To hide/unhide connectors and primary parts

TABLE II
MECHANICAL CAD CODES COMPATIBILITY FOR ASSEMBLY ATTRIBUTE EXTRACTION

S. No.	Software	Publisher	Direct Compatibility	API Compatibility
1.	Autodesk Inventor	AUTODESK INC.	3D solid Modelling and Assembly modelling.	C#
2.	Creo parametric (Pro Engineer)	Technology Corporation (PTC)	3D solid Modelling and Assembly modelling.	VB API/C++
3.	CATIA	Dassault Systems	3D solid Modelling and Assembly modelling.	CATScript /VBScript
4.	NX (UG or Unigraphics)	Siemens	3D solid Modelling and Assembly modelling.	C/C++
5.	Solidworks	Dassault Systems	3D solid Modelling and Assembly modelling.	Visual Basic

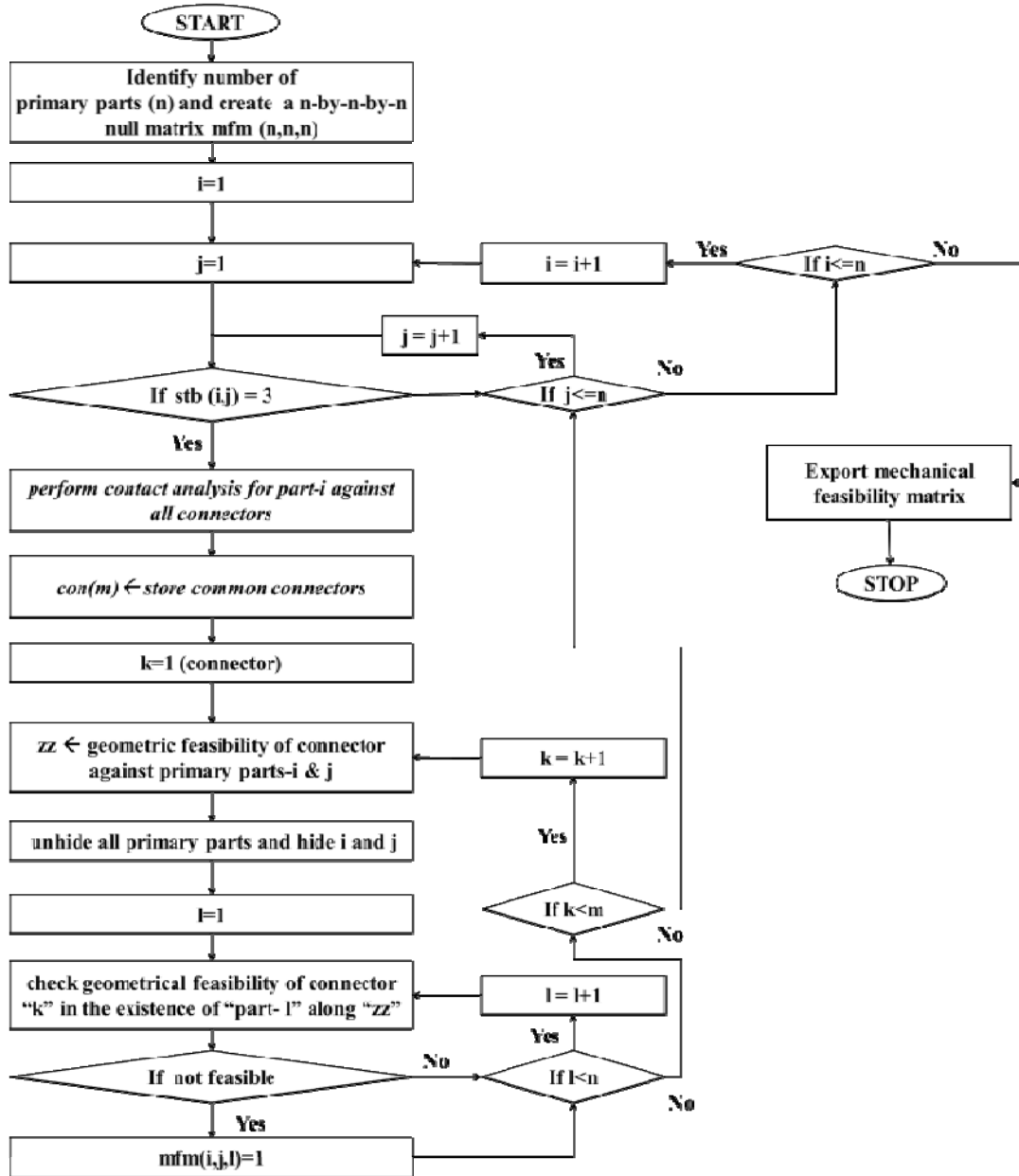

Fig. 13 Method to extract mechanical feasibility matrix

	A	B	C	D	E	F	G	H	J	K	L
A	0	0	0	0	0	0	0	0	0	0	0
B	0	0	0	0	0	0	0	0	0	0	0
C	0	0	0	0	0	0	0	0	0	0	0
D	0	0	0	0	0	0	0	0	0	0	0
E	0	0	0	0	0	0	0	0	0	0	0
F	0	0	0	0	0	0	0	0	0	0	0
G	0	0	0	0	0	0	0	0	0	0	0
H	0	0	0	0	0	0	0	0	0	0	0
J	0	0	0	0	0	0	0	0	0	0	0
K	0	0	0	0	0	0	0	0	0	0	0
L	0	0	0	0	0	0	0	0	0	0	0

Fig. 14 Mechanical feasibility matrix for transmission assembly

REFERENCES

- [1] A. Bourjault, 'Contribution a une approche methodologique de l'assemblage automatise: elaboration automatique des sequence s operatories', Ph.D. Thesis, L'Universite de Franche-Comte, 1984.
- [2] L. Homem de Mello and A. Sanderson, "A correct and complete algorithm for the generation of mechanical assembly sequences", *IEEE Trans. Robot. Automat.*, vol. 7, no. 2, pp. 228-240, 1991.
- [3] T. De Fazio and D. Whitney, "Simplified generation of all mechanical assembly sequences", *IEEE J. Robot. Automat.*, vol. 3, no. 6, pp. 640-658, 1987.
- [4] M. Bahubalendruni and B. Biswal, "A review on assembly sequence generation and its automation", *Proceedings of the Institution of Mechanical Engineers, Part C: Journal of Mechanical Engineering Science*, vol. 230, no. 5, pp. 824-838, 2015.
- [5] M. R. Bahubalendruni, B. B. Biswal, and V. Upadhyaya, Assembly Sequence Generation and Automation. In *Proceeding of International Symposium on Engineering and Technology*, pp185-192, 2014.
- [6] M. R. Bahubalendruni, B. Biswal, and G. R. Khanolkar, Computer aid to obtain assembly cut-sets from 3D CAD product. In *International Conference on Design, Manufacturing and Mechatronics*, pp. 161-167, 2014.
- [7] G. Dini, F. Failli, B. Lazzarini and F. Marcelloni, "Generation of Optimized Assembly Sequences Using Genetic Algorithms", *CIRP Annals - Manufacturing Technology*, vol. 48, no. 1, pp. 17-20, 1999.
- [8] R. Nayak, M. Bahubalendruni, B. Biswal and M. Kumar, "Comparison of liaison concatenation method with simulated annealing for assembly sequence generation problems", *2015 1st International Conference on Next Generation Computing Technologies (NGCT)*, 2015.
- [9] M. Bahubalendruni, B. Biswal and B. Deepak, "Optimal Robotic Assembly Sequence Generation Using Particle Swarm Optimization", *Journal of Automation and Control Engineering*, vol. 4, no. 2, pp. 89-95, 2016.
- [10] M. Bahubalendruni, B. Deepak and B. Biswal, "An advanced immune based strategy to obtain an optimal feasible assembly sequence", *Assembly Automation*, vol. 36, no. 2, pp. 127-137, 2016.
- [11] H. Shan, S. Zhou and Z. Sun, "Research on assembly sequence planning based on genetic simulated annealing algorithm and ant colony optimization algorithm", *Assembly Automation*, vol. 29, no. 3, pp. 249-256, 2009.
- [12] C. Pan, S. Smith and G. Smith, "Automatic assembly sequence planning from STEP CAD files", *International Journal of Computer Integrated Manufacturing*, vol. 19, no. 8, pp. 775-783, 2006.
- [13] A. Mathew and C. Rao, "A CAD system for extraction of mating features in an assembly", *Assembly Automation*, vol. 30, no. 2, pp. 142-146, 2010.
- [14] R. Viganò and G. Osorio Gómez, "Assembly planning with automated retrieval of assembly sequences from CAD model information", *Assembly Automation*, vol. 32, no. 4, pp. 347-360, 2012.
- [15] L. Ou and X. Xu, "Relationship matrix based automatic assembly sequence generation from a CAD model", *Computer-Aided Design*, vol. 45, no. 7, pp. 1053-1067, 2013.
- [16] M. Bahubalendruni and B. Biswal, "Computer aid for automatic liaisons extraction from cad based robotic assembly", *2014 IEEE 8th International Conference on Intelligent Systems and Control (ISCO)*, 2014.
- [17] Z. Ling. and S. Narayan, "Heuristic feature recognition from a CAD model". *Integrated Computer-Aided Engineering*, vol. 3, no. 3, pp. 212-224, 1996.
- [18] T. Eng, Z. Ling, W. Olson and C. McLean, "Feature-based assembly modeling and sequence generation", *Computers & Industrial Engineering*, vol. 36, no. 1, pp. 17-33, 1999.
- [19] M. R. Bahubalendruni, B. Biswal, and G. R. Khanolkar, "A Review on Graphical Assembly Sequence Representation Methods and Their Advancements ", *Journal of Mechatronics and Automation*, vol. 1, no.2, pp. 16-26, 2015.
- [20] Alfadhilani, T. Samadhi, A. Ma'ruf and I. Toha, "Automatic Collision Detection for Assembly Sequence Planning Using a Three-Dimensional Solid Model", *Journal of Advanced Manufacturing Systems*, vol. 10, no. 02, pp. 277-291, 2011.
- [21] P. GU and X. YAN, "CAD-directed automatic assembly sequence planning", *International Journal of Production Research*, vol. 33, no. 11, pp. 3069-3100, 1995.
- [22] S. Mok, K. Ong and C. Wu, "Automatic generation of assembly instructions using STEP", *Proceedings 2001 ICRA. IEEE International Conference on Robotics and Automation (Cat. No.01CH37164)*.
- [23] M. Raju Bahubalendruni and B. Biswal, "An Intelligent Method to Test Feasibility Predicate for Robotic Assembly Sequence Generation", *Advances in Intelligent Systems and Computing*, pp. 277-283, 2014.
- [24] M. Raju Bahubalendruni and B. Biswal, "An algorithm to test feasibility predicate for robotic assemblies." *Trends in Mechanical Engineering & Technology*. Vol.4, no.2 pp.11-16, 2014.
- [25] W. Chen, Y. Hsu, L. Hsieh and P. Tai, "A systematic optimization approach for assembly sequence planning using Taguchi method, DOE, and BPNN", *Expert Systems with Applications*, vol. 37, no. 1, pp. 716-726, 2010.
- [26] M. Raju Bahubalendruni and B. BISWAL, "Liaison concatenation – A method to obtain feasible assembly sequences from 3D-CAD product", *Sadhana*, vol. 41, no. 1, pp. 67-74, 2016.
- [27] Q. Guan, J. Liu and Y. Zhong, "A concurrent hierarchical evolution approach to assembly process planning", *International Journal of Production Research*, vol. 40, no. 14, pp. 3357-3374, 2002.
- [28] M. Bahubalendruni and B. Biswal, "A novel concatenation method for generating optimal robotic assembly sequences", *Proceedings of the Institution of Mechanical Engineers, Part C: Journal of Mechanical Engineering Science*, 2015. doi: 10.1177/0954406215623813.
- [29] M. Bahubalendruni, B. Biswal, M. Kumar and R. Nayak, "Influence of assembly predicate consideration on optimal assembly sequence generation", *Assembly Automation*, vol. 35, no. 4, pp. 309-316, 2015.
- [30] S. Shiang-Fong Smith, G. Smith and X. Liao, "Automatic stable assembly sequence generation and evaluation", *Journal of Manufacturing Systems*, vol. 20, no. 4, pp. 225-235, 2001.
- [31] M. Kumar, M. V. A. Bahubalendruni and B. B. Biswal and R. Nayak, "Identification of stable configurations between constituent parts of an assembly", *International Conference on Mechanical Engineering Design (ICMED-2016), 25-26 April 2016*, Chennai, India, 2016.
- [32] M. R. Bahubalendruni, B. B. Biswal, M. Kumar and B. V. L Deepak, "A Note on Mechanical Feasibility Predicate for Robotic Assembly Sequence Generation". In *CAD/CAM, Robotics and Factories of the Future* (pp. 397-404). Springer India, 2016.