

# Quartz Crystal Microbalance Holder Design for On-Line Sensing in Liquid Applications

M. A. Amer, J. A. Chávez, M. J. García-Hernández, J. Salazar, A. Turó

**Abstract**—In this paper, the design of a QCM sensor for liquid media measurements in vertical position is described. A rugged and low-cost proof holder has been designed, the cost of which is significantly lower than those of traditional commercial holders. The crystal is not replaceable but it can be easily cleaned. Its small volume permits to be used by dipping it in the liquid with the desired location and orientation. The developed design has been experimentally validated by measuring changes in the resonance frequency and resistance of the QCM sensor immersed vertically in different calibrated aqueous glycerol solutions. The obtained results show a great agreement with the Kanazawa theoretical expression. Consequently, the designed QCM sensor would be appropriate for sensing applications in liquids, and might take part of a future on-line multichannel low-cost QCM-based measurement system.

**Keywords**—Holder design, liquid-media measurements, multi-channel measurements, QCM.

## I. INTRODUCTION

**T**HICKNESS-Shear Mode (TSM) sensors, namely QCM, are highly sensitive devices not only able to measure the addition of very small mass, but also non-gravimetric contributions of viscoelastic media, which can be operated in air, aqueous conditions and under vacuum. QCM usually consists of a thin AT-cut quartz wafer with two metallic electrodes deposited uniformly onto both sides of the crystal. Due to the piezoelectric effect, when an AC electrical field is applied perpendicular to the plate, a shear wave is generated that propagates through the quartz crystal inducing its oscillation. This propagation is modified when the faces of the crystal are loaded by a material.

QCM sensors are becoming a great alternative to analytical methods of measurement in a wide range of application areas involving small molecular weight ligands, carbohydrates, proteins, nucleic acids, viruses, bacteria, cells, and membrane interfaces [1], [2]. When the QCM sensor is introduced into a liquid, only one of the two crystal faces is in contact to the liquid. For this reason, the traditional design of commercial holders consists of a recipient with the crystal element attached to the bottom by supporting it by means of toroidal rubber O-rings that provide sealing between the liquid and the face with the electrical contacts. These holders use to have several parts and screws to permit the crystal replacement.

M. A. Amer is with the Escola Universitària Salesiana de Sarrià, Passeig Sant Joan Bosco 74, 08017 Barcelona, Spain (e-mail: maamer@euss.es).

J. A. Chávez, M.J. García-Hernández, J. Salazar, A. Turó are with the Sensor Systems Group. Department of Electronic Engineering. Universitat Politècnica de Catalunya, Jordi Girona 1-3, 08034 Barcelona, Spain.

Accordingly, the mounting and the placement of the crystal in the holder is critical as the operation and the sensitivity of the QCM is very dependent on them. In addition, these holders usually are very big and expensive. These facts make these holders unsuitable for some kinds of online measurements in liquid media. Alternatively, in this paper a new QCM holder is proposed. So, the QCM sensor is placed in vertical in the lid of commercial standard low-cost culture plates as measuring cells. For a proper use of the QCM sensor, a specific holder is designed, in which only one of the crystal faces is in contact with the liquid media. The crystal is not replaceable, but the holder may be easily replaced or cleaned. The cost of the whole holder is significantly lower than the commercial ones and can be an interesting alternative for developing a low-cost QCM-based liquid measurement system.

## II. THEORETICAL

### A. Electrical Impedance of a Quartz Crystal Resonator.

The electrical impedance or admittance [3] of a QCM is influenced by the acoustic load at its faces. It depends on the electrical capacitance formed by the electrodes and the quartz as a dielectric material and the so-called motional impedance, which is contributed by the acoustic load impedance ( $Z_L$ ), acting at the surfaces of the quartz plate. The acoustic load impedance can consist of a single rigid film, a semi-infinite Newtonian liquid, a single viscoelastic film or a multilayer arrangement.

### B. The Butterworth van Dyke Equivalent Circuit.

Near resonance, the electrical impedance of a QCM can be reduced to the Butterworth van Dyke (BVD) electrical equivalent model [4] as depicted in Fig. 1, where the physical parameters are summarized in lumped equivalent electrical values: electrical capacitance, motional inductance, motional capacitance and motional resistance.

According to Fig. 1, the BVD circuit consists of two parallel branches: the upper branch consisting of only the capacitance  $C_0$  represents the fixed dielectric capacitance of the resonator. All of the motional information is contained in the lower branch.

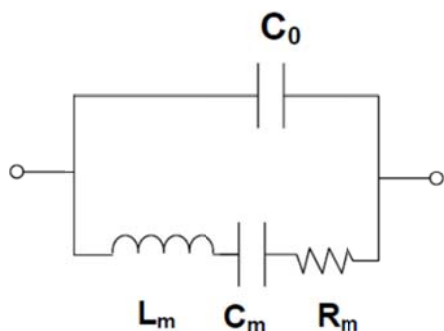

Fig. 1 Butterworth-van Dyke model of Quartz Crystal Resonator

The motional arm has three series components modified by the mass and viscous loading at the faces of the crystal: (1) resistor  $R_m$  corresponds to the dissipation of the oscillation energy from mounting structures and from the medium in contact with the crystal (i.e. losses induced by a viscous solution), (2) capacitor  $C_m$  corresponds to the stored energy in the oscillation and is related to the elasticity of the quartz and the surrounding medium, and (3) inductor  $L_m$  corresponds to the inertial component of the oscillation, which is related to the mass displaced during the vibration. Typical values of these parameters for a 1" diameter and 5MHz crystal are  $C_m=33\text{fF}$ ,  $L_m=30\text{mH}$ , and  $R_m=10\Omega$  (air-loaded crystal), or  $R_m=400\Omega$  (water-loaded crystal). The motional arm is shunted by the parasitic capacitance,  $C_o$ , which represents the sum of the static capacitances of the crystal's electrodes, holder, and connector capacitance.

For such an electrical circuit, the variation of the impedance with frequency becomes minimum close to the series resonance frequency given by (1):

$$f_0 = 1/2\pi (L_m C_m)^{1/2} \quad (1)$$

In a QCM application the motional inductance,  $L_m$ , is increased when mass is added to the crystal electrode. The frequency shift of the series resonance is a sensitive indicator of the added mass and films of less than  $1\text{ng/cm}^2$ . Also, from the BVD electrical circuit can be deduced that the minimum impedance at the series resonance frequency is given by the motional resistance,  $R_m$ . Its measurement can provide important information about a process since soft films and viscous liquids increase motional losses, i.e., the value of  $R_m$ .

### C. Liquid-Contact Measurements.

The Sauerbrey expression (2) [5] is commonly used to relate mass loading and resonant frequency shift,  $\Delta f$ :

$$\Delta f = - C \cdot \Delta m \quad (2)$$

where  $C$  is the sensitivity factor of the resonator in  $\text{Hz}/(\text{ng}/\text{cm}^2)$ , and  $\Delta m$  is the change in mass per unit area in  $\text{ng}/\text{cm}^2$ . This expression is only valid for a homogeneous film rigidly attached to the QCM surface.

In the case of liquids the operation of the QCM is also possible [6] and its electrical impedance is sensible to the changes at the interface between the crystal and the liquid. The

works carried out by Glassford [7], and later by Kanazawa and Gordon [8], [9] demonstrated the resonance frequency dependence upon the viscosity and the density of the liquid solution in contact with the QCM.

The change in the resonance frequency due to the liquid solution properties is given by (3):

$$\Delta f = - f_0^{3/2} (\eta_l \cdot \rho_l / \pi \cdot \mu_q \cdot \rho_q)^{1/2} \quad (3)$$

where  $f_0$  is the resonant frequency,  $\rho_l$  is the density of the liquid,  $\eta_l$  is the viscosity of the liquid,  $\rho_q$  and  $\mu_q$  are the density and rigidity modulus of the quartz crystal respectively. On the other hand, viscous coupling of the liquid medium to the crystal surface results in damping of the resonant oscillation. The viscous loss is manifested as an increase in series resonance resistance,  $R_m$ , of the QCM resonator. Thus, the measurement of this resistance is a good indicator to obtain the liquid solution viscosity. The change in the series resonance resistance of the QCM under liquid loading [10] is given by (4):

$$\Delta R = [n \omega_s \cdot L_u / \Pi] \cdot [2 \omega_s \cdot \rho_l \cdot \eta_l / (\rho_q \cdot \mu_q)]^{1/2} \quad (4)$$

where  $\Delta R$  is change in series resonance resistance in  $\Omega$ ,  $n$  is the number of sides in contact with liquid,  $\omega_s$  is angular frequency at series resonance, and  $L_u$  is the inductance for the unperturbed (i.e. dry) resonator (usually in mH).

### III. HOLDER DESCRIPTION

For a properly use in liquid media measurements in vertical position, a new QCM sensor holder has been designed. The holder design is based on one-piece compact construction that houses the quartz crystal whose back face is maintained without any contact or acoustic loading. Silicone paste is used to provide the required sealing to prevent the penetration of the liquid into the interior. Two designs have been developed to use with 1" and  $\frac{1}{2}$ " commercial quartz crystals.

Two holder materials have been selected in order to be resistant and compatible with liquids. The version V1.0 is manufactured in methacrylate (Fig. 2). The version V2.0 is manufactured in ABS (Acrylonitrile Butadiene Styrene) polymer or Bentley®, by means of a 3D printer (Fig. 3).

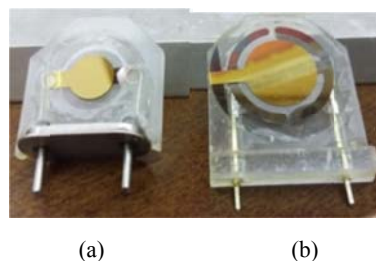

Fig. 2 Image of the version V1.0 methacrylate holder (a) ICM  $\frac{1}{2}$ " sensor (b) INFICON 1" sensor

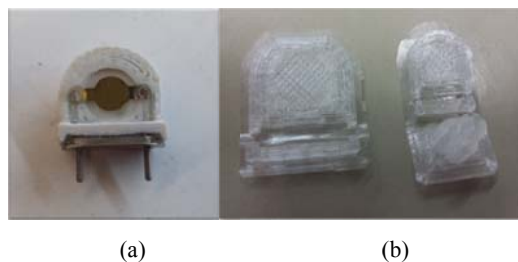

Fig. 3 Image of the version V2.0 holder (a) ABS polymer holder (b) Bentley® holder

For this work, two commercial QCM sensors have been chosen. The first one is a 1" sensor manufactured from INFICON (ref. 149257-1), and the second one is a 1/2" sensor manufactured from ICM (International Crystal Manufacturing) (ref. 151527-5). Both of them are AT-cut quartz crystal discs with a resonant frequency of 5MHz and gold plated titanium electrodes. The surface of the electrodes is polished and optimized for a working temperature of 25 °C (Fig. 4).

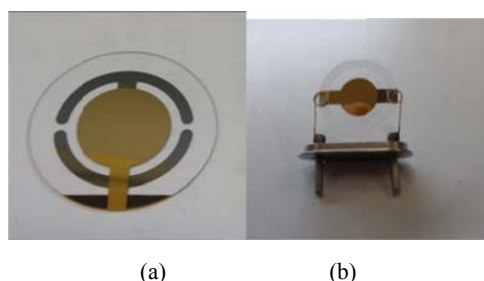

Fig. 4 Image of the ICM sensors used (a) INFICON 1" (b) ICM 1/2"

#### IV. MATERIALS AND METHODS

##### A. Samples

Reagents used to prepare the mixtures were distilled water and Glycerol 99% analytical grade (Labkem, Mataró (Barcelona), Catalonia, Spain). Glycerol solutions at 20%, 40%, 60% and 80% have been prepared from Glycerol 99% by weighing the reagents using a Cobos CB-Compleat analytical balance with a precision of 0.001 g. Density and viscosity values for these solutions have been obtained from literature [11].

##### B. Measurements

QCM sensor holders, described in Section III, were immersed in glycerol aqueous solutions at 0%, 20%, 40%, 60% and 80% v/v, which were placed in a 250 ml glass beaker. Sensor resonant frequency and resistance measurements were made by using an Agilent 4294A Impedance Analyzer.

#### V. RESULTS AND DISCUSSION

In order to validate the sensor holder, it was calibrated using glycerol solutions by measuring the resonant frequency and resistance, as described in Section IV B. Figs. 5 and 6 show the results obtained by using the ICM Crystal.

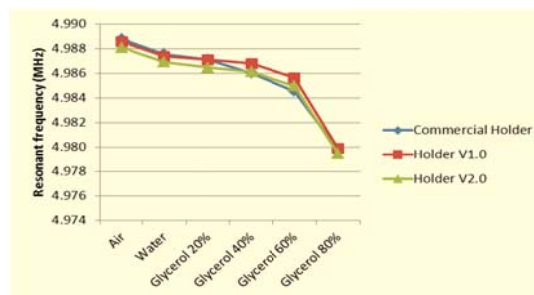

Fig. 5 Resonant frequency measurements (in Hz) for different liquids media and holders, using the ICM Crystal

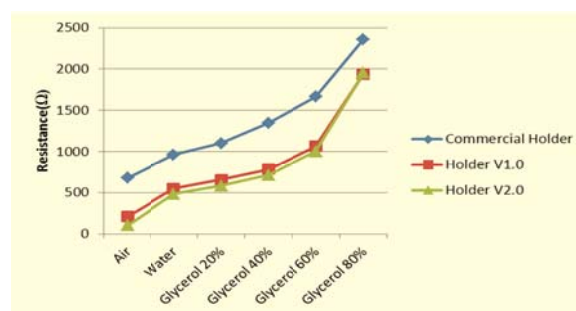

Fig. 6 Resistance measurements (in Ω) for different liquids media and holders, using the ICM Crystal

In Fig. 5, resonant frequency measurements obtained by using the holders described in Section III are compared with the values obtained by using a commercial one. The results shown a good agreement for the different liquid media tested. Similarly, in Fig. 6, the resistance measurements are compared for different liquid media. In this case, the results obtained by using both holders described in Section III are similar, but shows a significant offset discrepancy if they are compared with the results for a commercial holder.

From results obtained in Fig. 5, it is possible to plot the resonant frequency variations, related to air, for the same liquid media and holders (Fig. 7). These results are compared with the theoretical values obtained from Kanazawa expression (3), and using the theoretical values of density and viscosity obtained from literature. Similarly to Fig. 5, results plotted in Fig. 7 are quite similar when the different holders are compared, but show a significant difference with the theoretical values, especially for high viscosity liquids (Glycerol 80%). This is due to the significant losses caused by the viscosity effect. Accordingly, the minimum impedance frequency does not agree with the resonant one [12]. Similarly, resistance variations for different liquid media, related to air, are represented in Fig. 8. These results are compared with the theoretical values obtained from expression (4). As in Fig. 7, results show a good agreement when the values obtained from the different holders are compared, but a disagreement with the theoretical values in case of high viscosity liquids (Glycerol 80%).

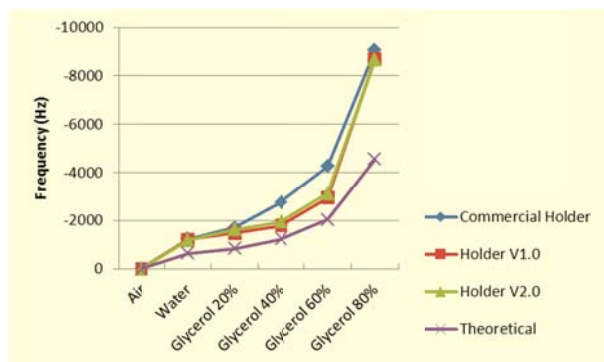

Fig. 7 Resonant frequency measurement variations (in Hz), related to air, for different liquids media and holders, using an ICM Crystal

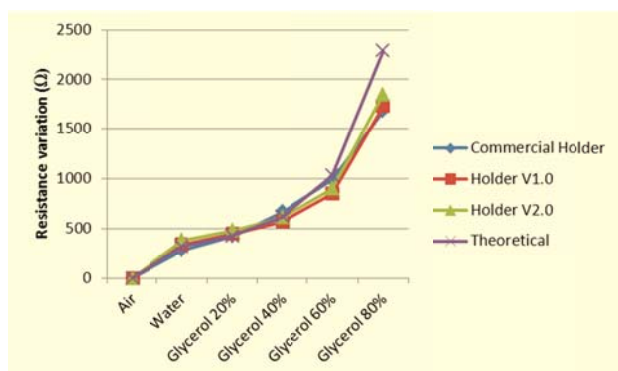

Fig. 8 Resistance measurement variations (in  $\Omega$ ), related to air, for different liquids media and holders, using an ICM Crystal

## VI. CONCLUSIONS

A new QCM low-cost holder for liquid media has been developed and tested, by measuring changes in the resonance frequency and resistance of the QCM sensor immersed vertically in different calibrated aqueous glycerol solutions. Results obtained show a great agreement with the ones achieved by using a commercial holder. If the values are compared with the theoretical ones obtained from Kanazawa expression, only significant discrepancies for high viscosity liquids are observed.

## ACKNOWLEDGMENT

This work is financially supported by the Spanish Ministerio de Economía y Competitividad Project with reference DPI2013-46915-C2-2-R.

## REFERENCES

- [1] Robert E. Speight and Matthew A. Cooper, "A Survey of the 2010 Quartz Crystal Microbalance Literature" *J. Mol. Recognit.* 2012; 25: 451–473, pp. 15–64.
- [2] Sandeep Kumar Vashist and Priya Vashist, "Recent Advances in Quartz Crystal Microbalance-Based Sensors", *Journal of sensors*, vol. 2011, Article ID 571405, 13 pages.
- [3] A. Arnau (Ed.), "Piezoelectric Transducers and Applications", Springer-Verlag, Berlin Heidelberg (2004), pp 73-74.
- [4] John Henderson, "Electronic Devices. Concepts and Applications", Prentice Hall, NJ, (1991) p. 357.
- [5] Sauerbrey G 1959 Use of quartz crystal vibrator for weighting thin films on a microbalance *Z Phys.* 155 206-222.

- [6] T. Nomura and M. Okuhara, *Anal. Chim. Acta* 142(1982) 281.
- [7] A. P. M. Glassford, "Response of a Quartz Crystal Microbalance to a liquid Deposit", *J. Vac. Sci. Technol.*, 15(6) (1978) 1836.
- [8] K. Keiji Kanazawa and Joseph Gordon II, "Frequency of a Quartz Microbalance in Contact with Liquid", *Anal. Chem.* 57(1985) 1770
- [9] K. Keiji Kanazawa and Joseph G. Gordon II, *Analytica Chimica Acta*, 175(1985) 99-105.
- [10] Stephen Martin, Victoria Edwards Granstaff and Gregory C. Frye, "Characterization of a Quartz Crystal Microbalance with Simultaneous Mass and Liquid Loading", *Anal. Chem.* 63 (1991) 2272.
- [11] Glycerine Producer's Association (New York) Handbook, "Physical Properties of Glycerine and Its Solutions".
- [12] A. Arnau, "A Review of Interface Electronic Systems for AT-cut Quartz Crystal Microbalance Applications in Liquids", *Sensors* 2008, 8, 370-411.