

FIGURE 1

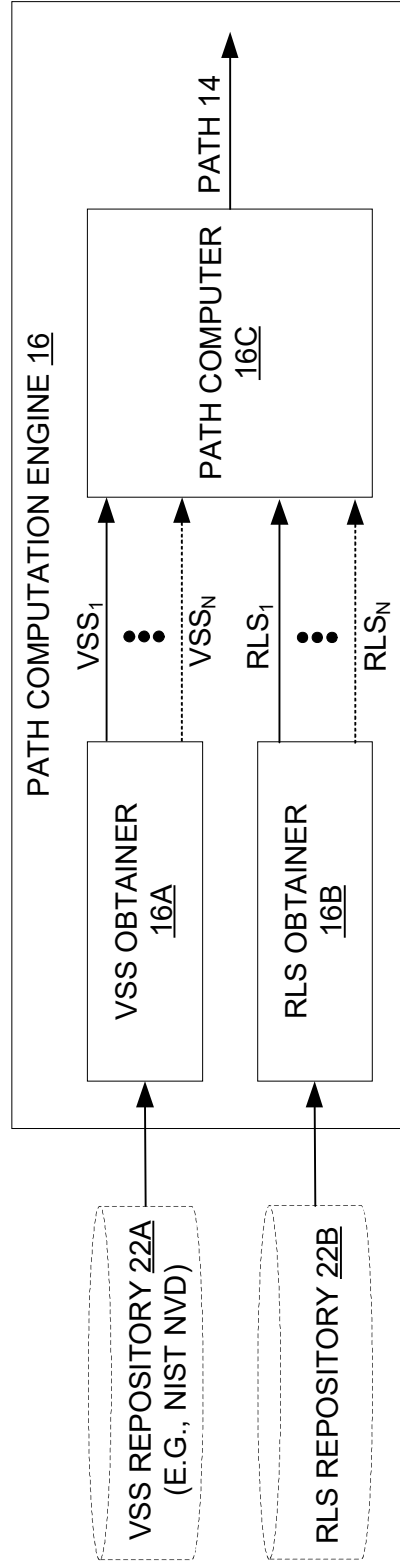

FIGURE 2

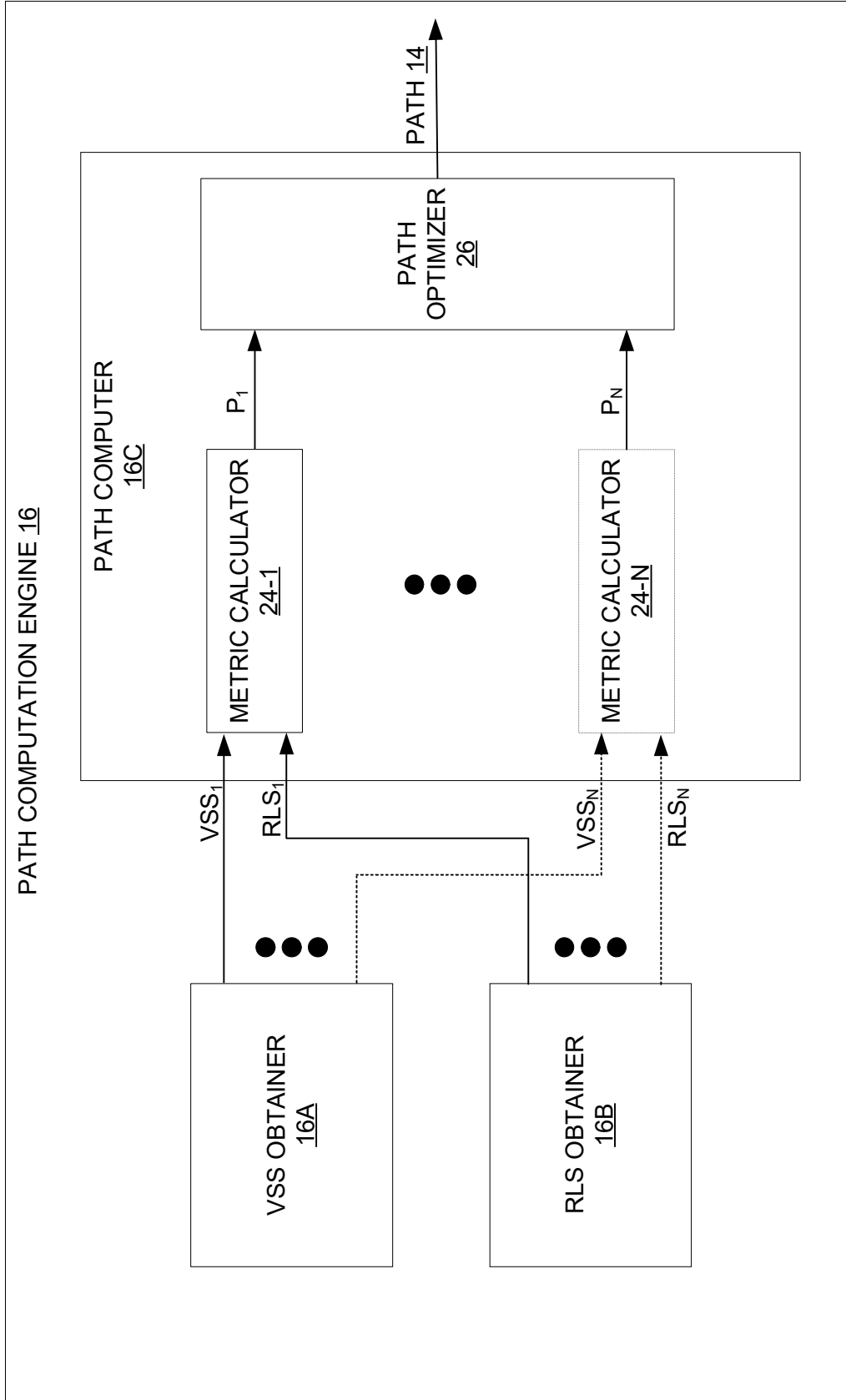

FIGURE 3

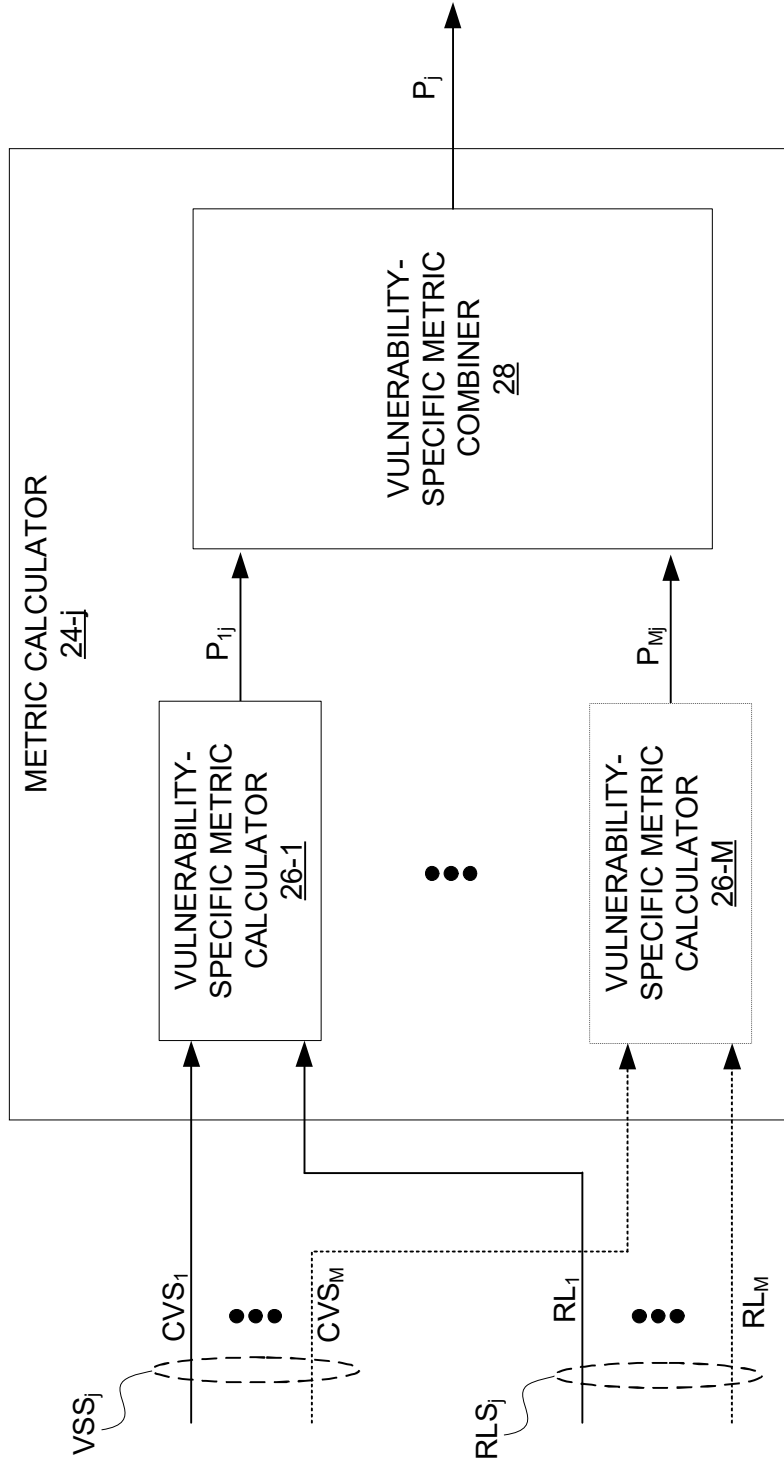

FIGURE 4

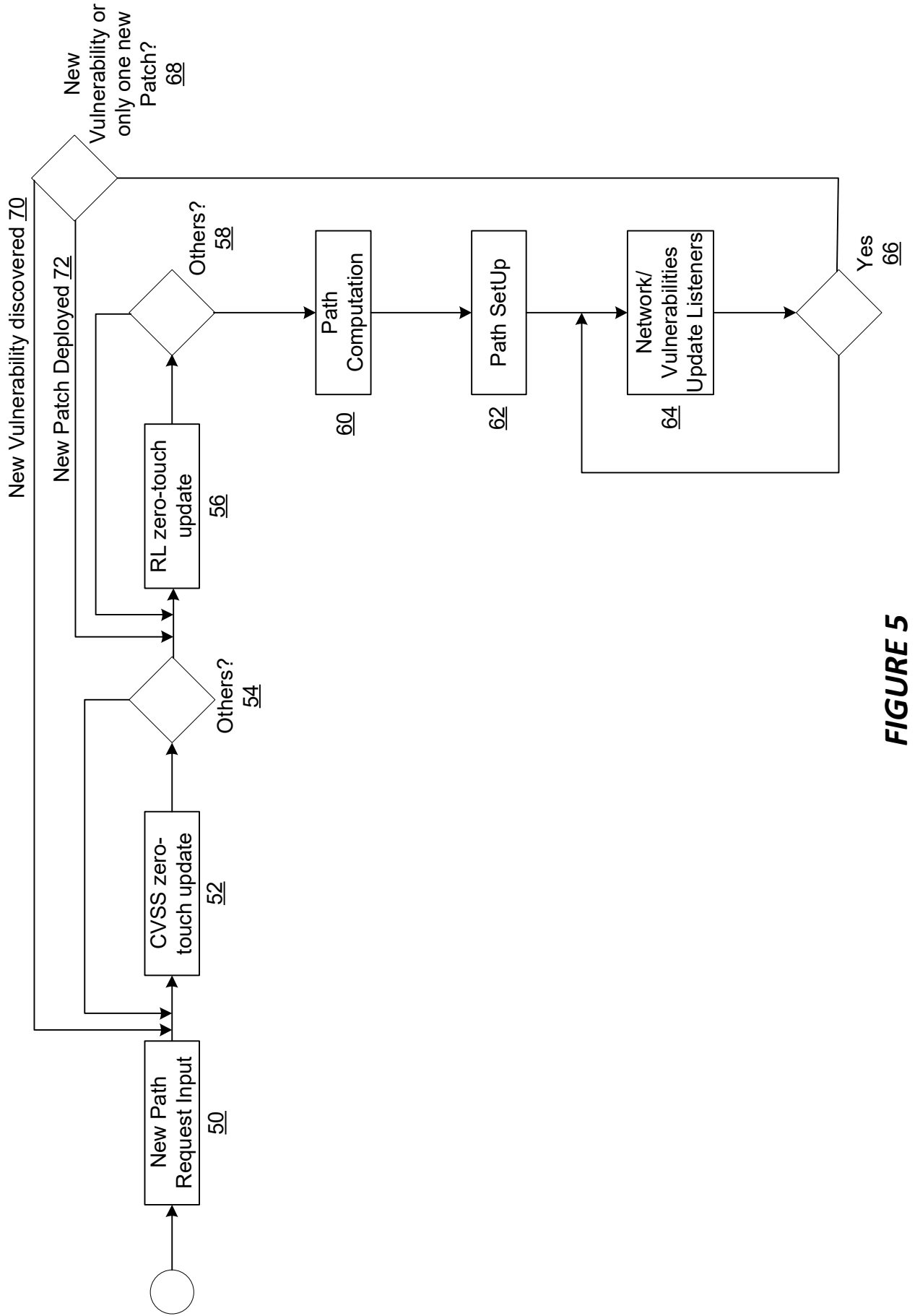

FIGURE 5

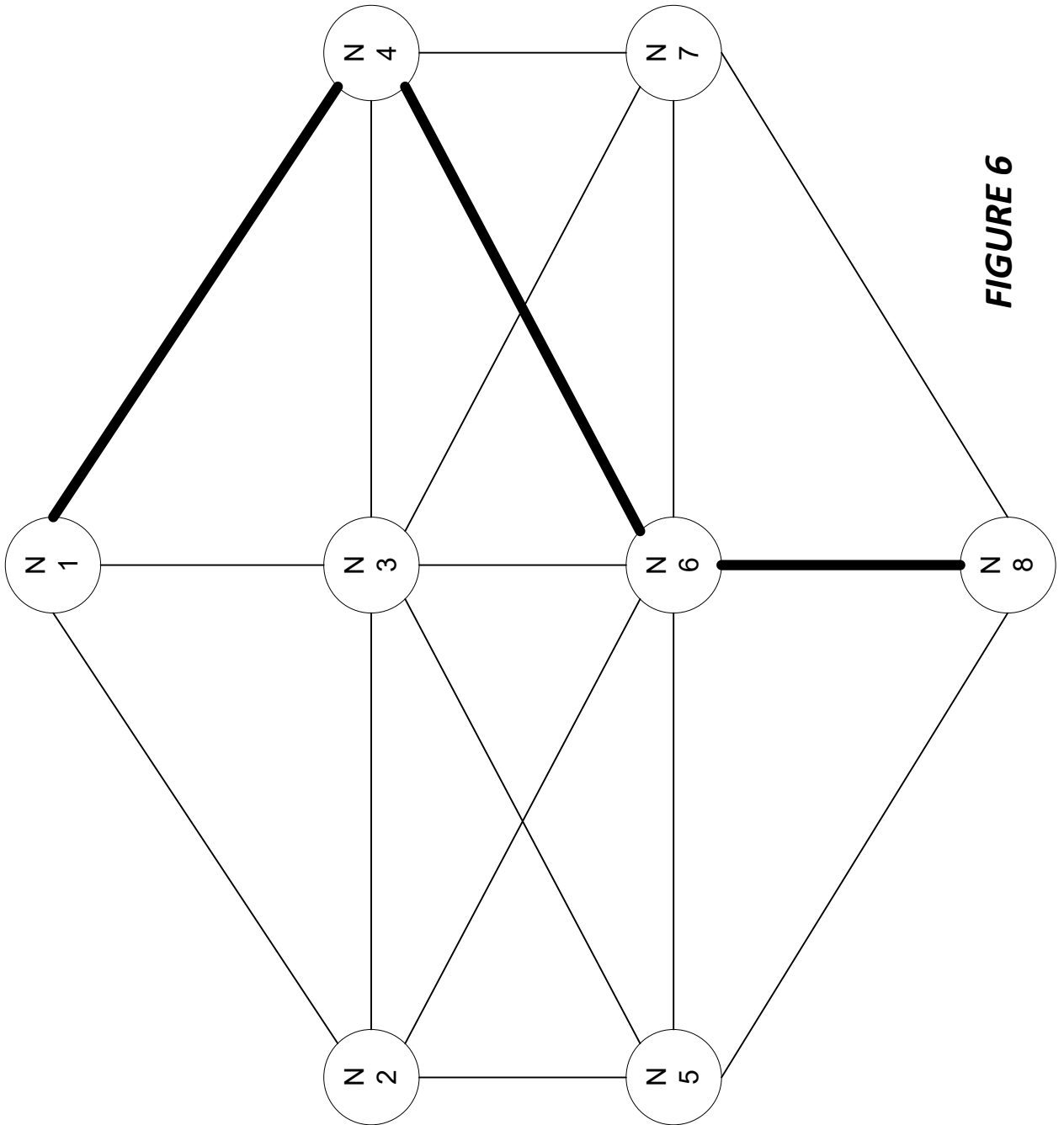
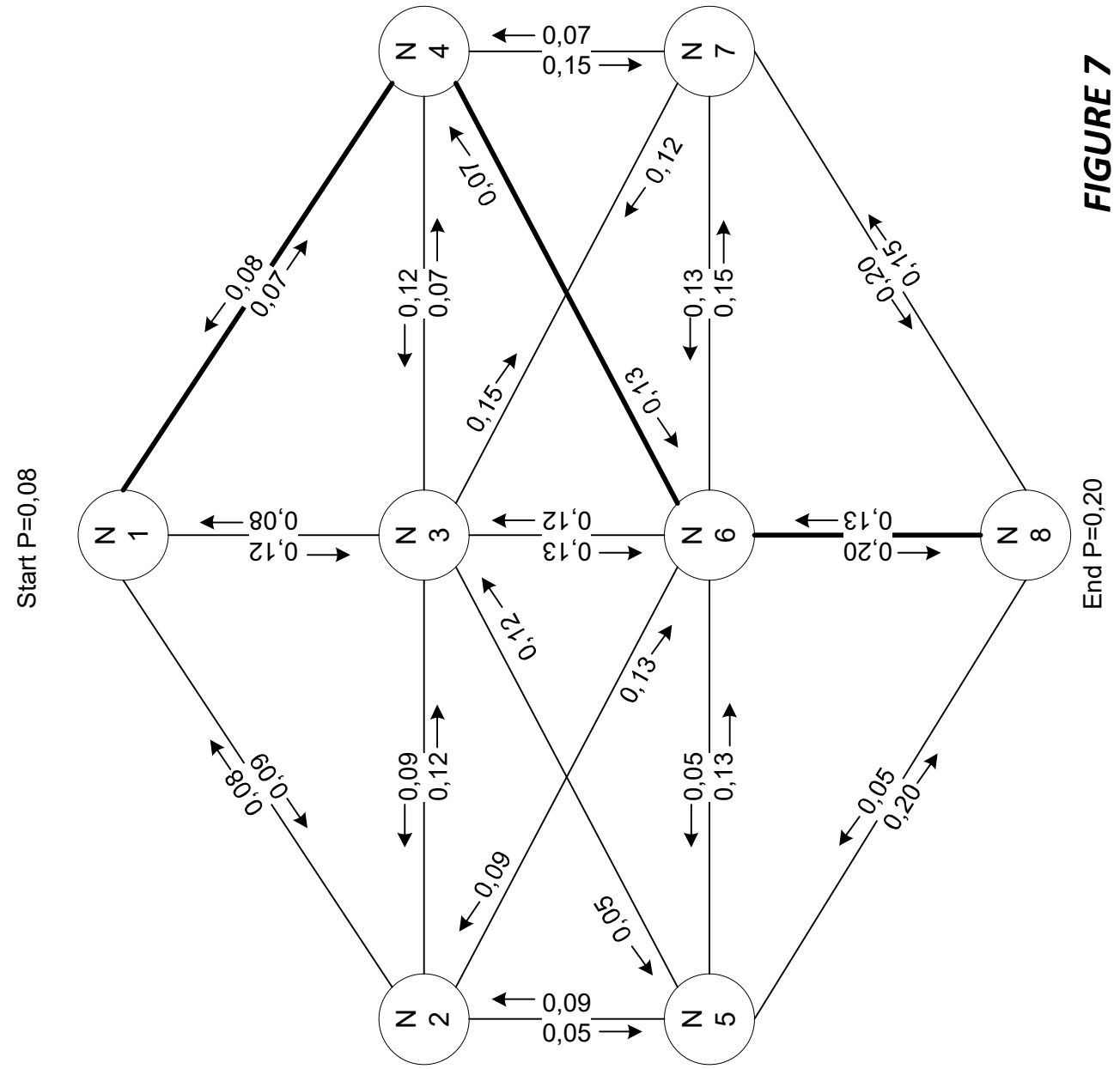

FIGURE 6



Start P=0,08

End P=0,20

Node number: j	Pj
1	0,08
2	0,09
3	0,12
4	0,07
5	0,05
6	0,13
7	0,15
8	0,20
Total	0,74

FIGURE 7

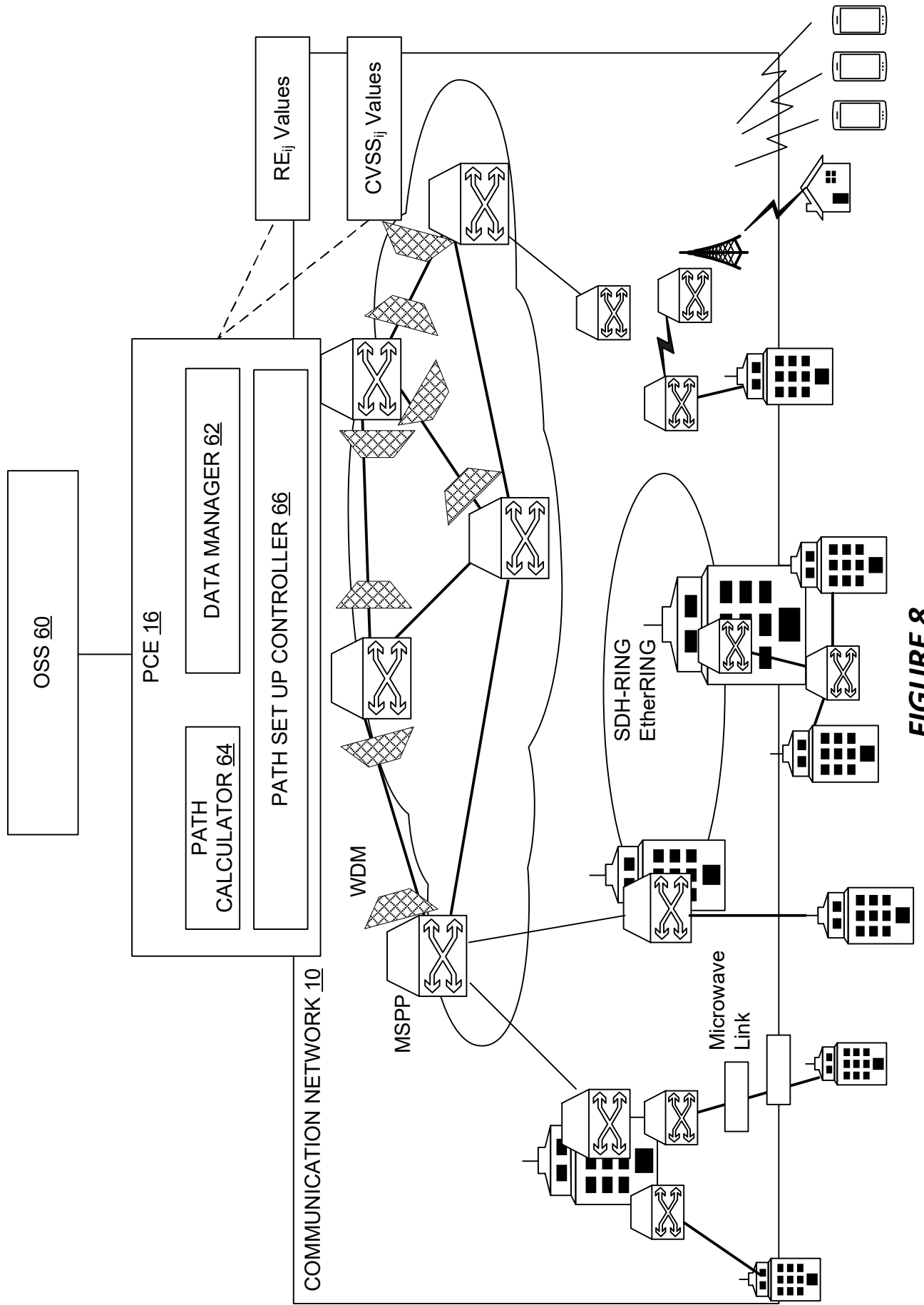

FIGURE 8

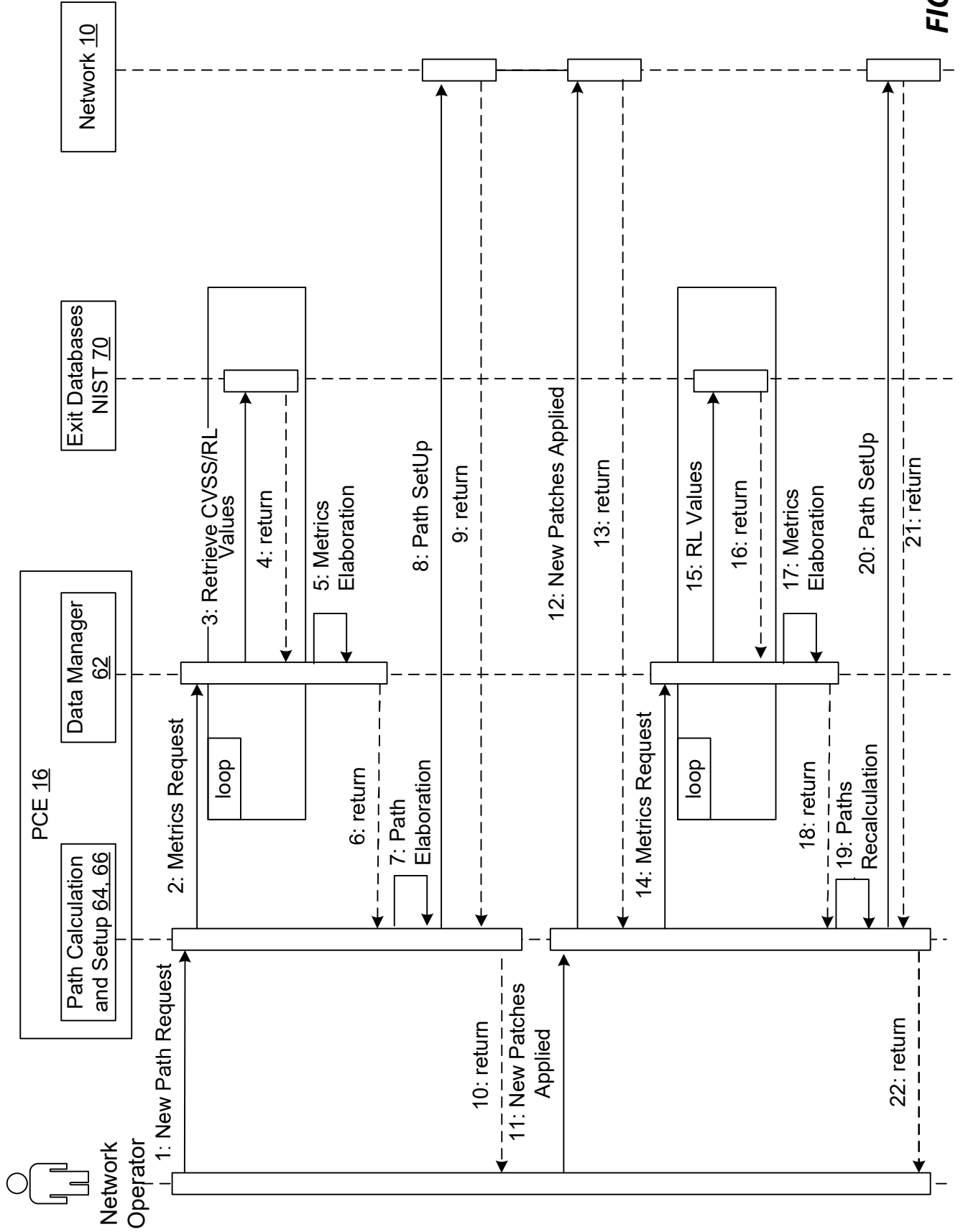
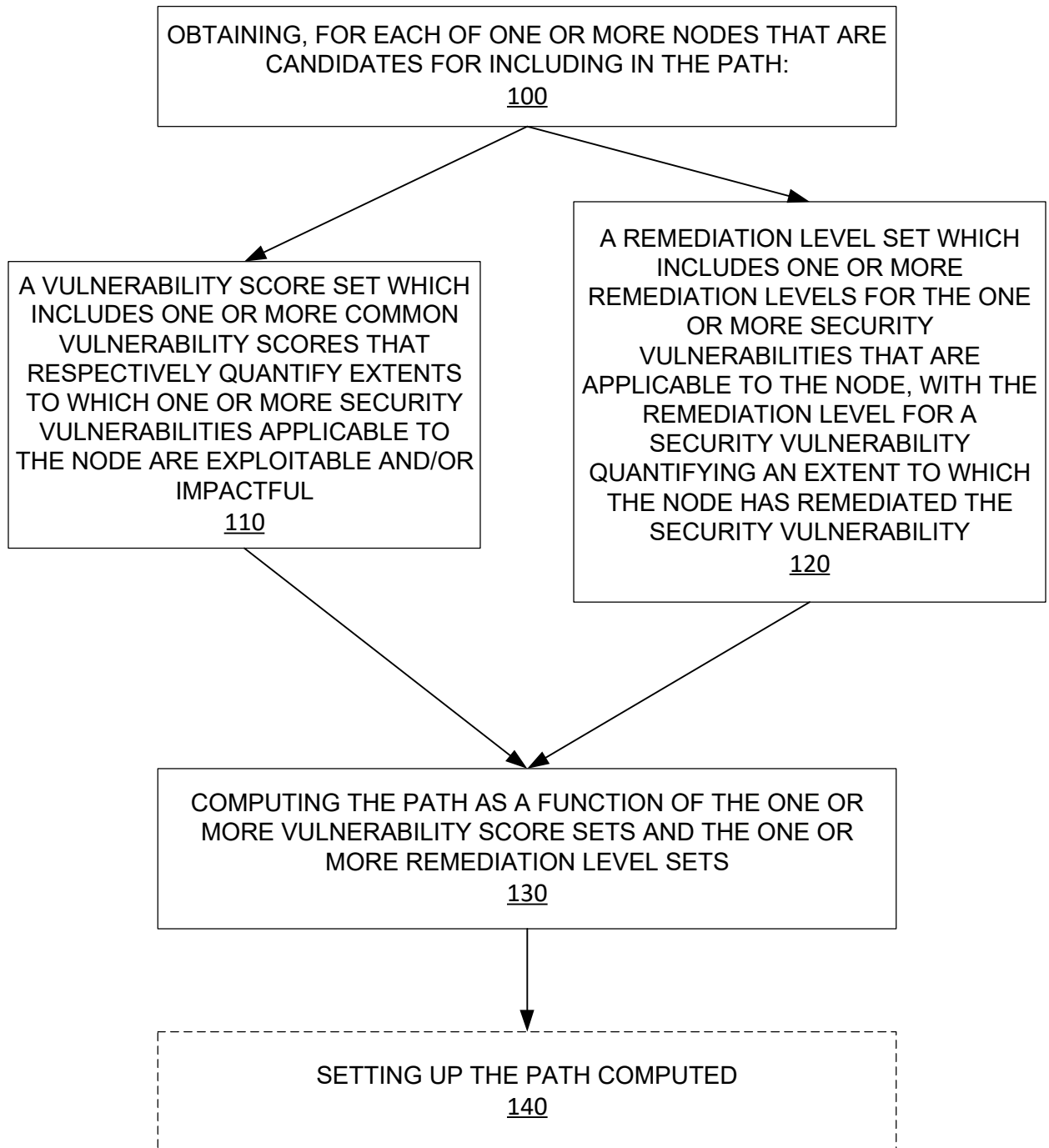

FIGURE 9

**FIGURE 10**

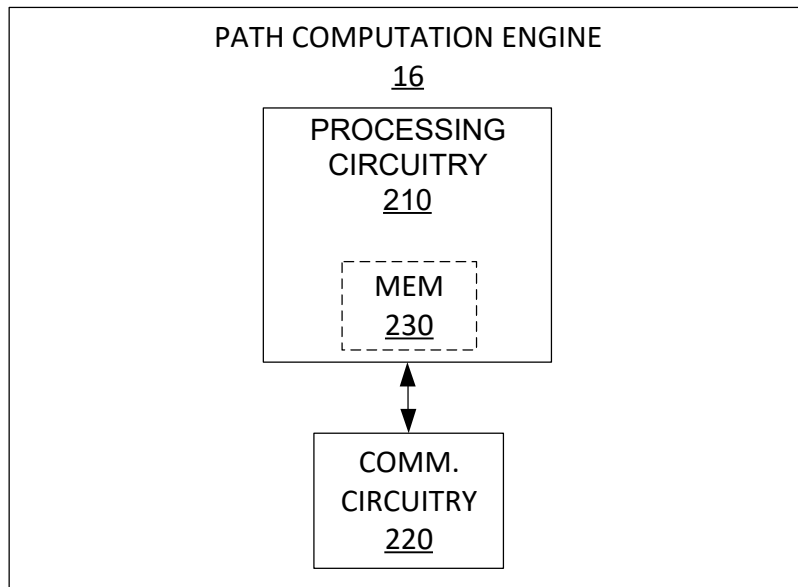

FIGURE 11

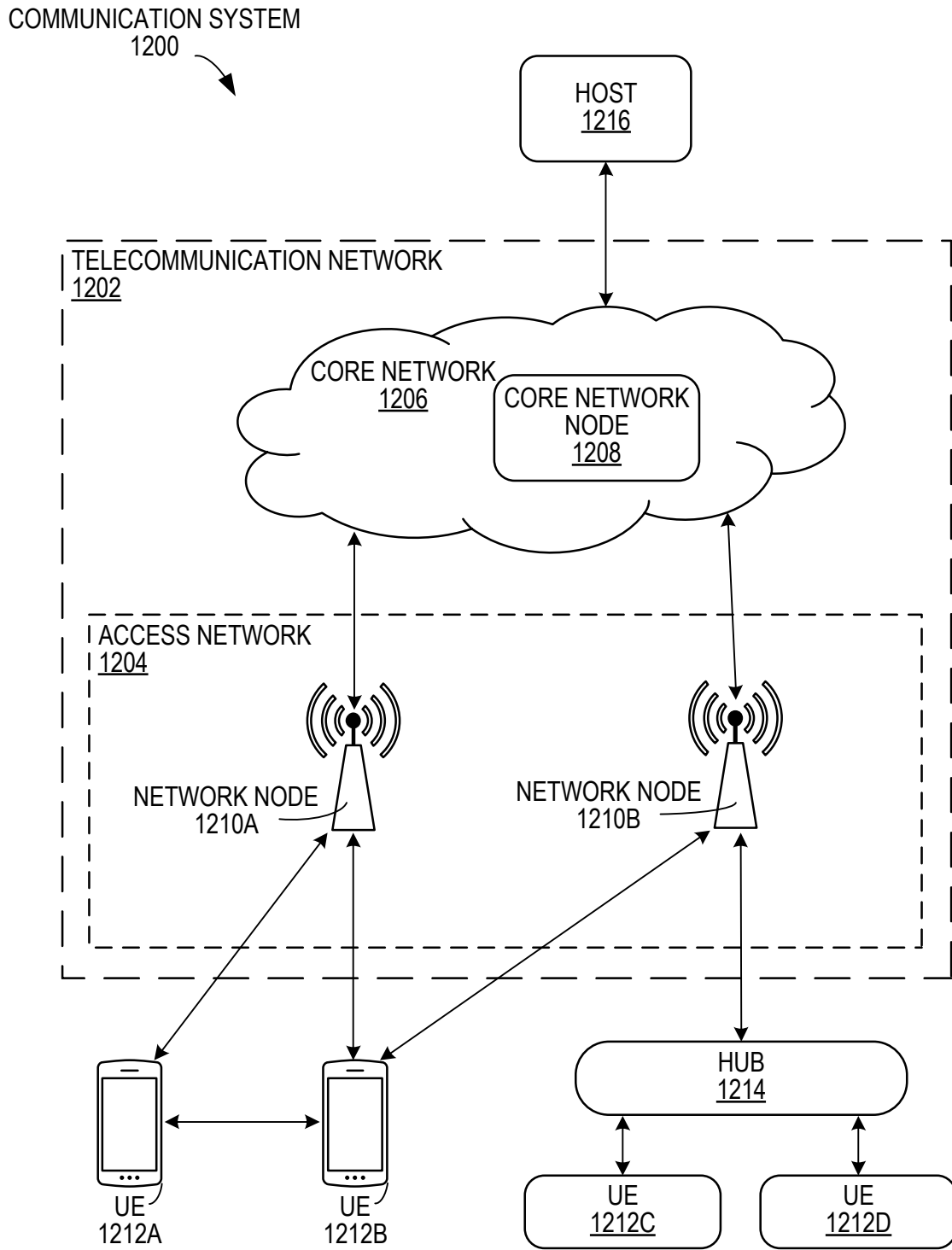

FIGURE 12

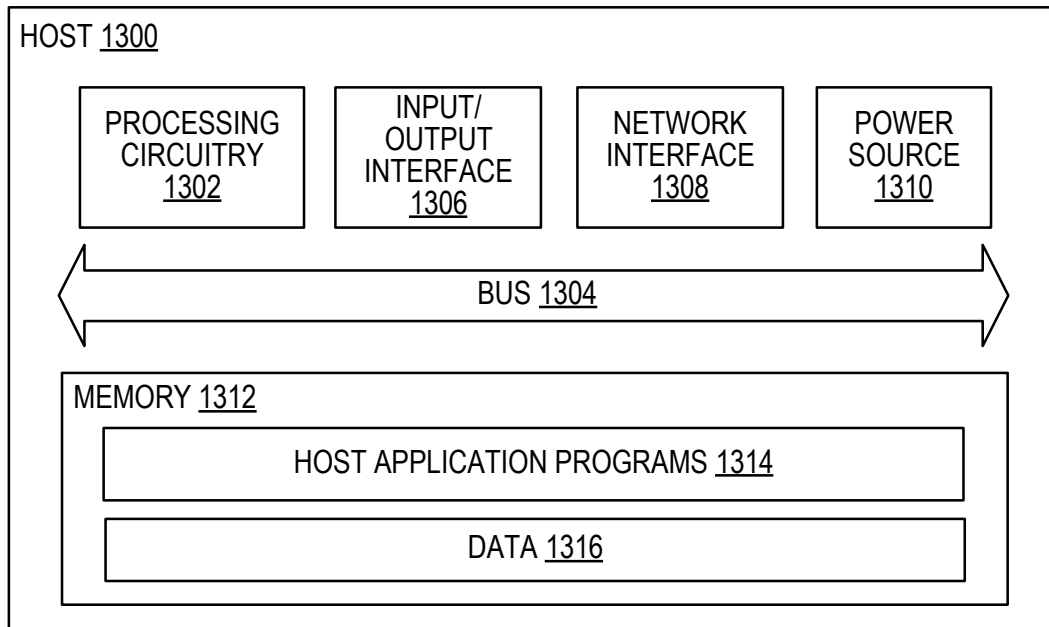

FIGURE 13