

# Fuzzy Tuned PID Controller with D-Q-O Reference Frame Technique Based Active Power Filter

Kavala Kiran Kumar, R. Govardhana Rao

**Abstract**—Active power filter continues to be a powerful tool to control harmonics in power systems thereby enhancing the power quality. This paper presents a fuzzy tuned PID controller based shunt active filter to diminish the harmonics caused by non linear loads like thyristor bridge rectifiers and imbalanced loads. Here Fuzzy controller provides the tuning of PID, based on firing of thyristor bridge rectifiers and variations in input rms current. The shunt APF system is implemented with three phase current controlled Voltage Source Inverter (VSI) and is connected at the point of common coupling for compensating the current harmonics by injecting equal but opposite filter currents. These controllers are capable of controlling dc-side capacitor voltage and estimating reference currents. Hysteresis Current Controller (HCC) is used to generate switching signals for the voltage source inverter. Simulation studies are carried out with non linear loads like thyristor bridge rectifier along with unbalanced loads and the results proved that the APF along with fuzzy tuned PID controller work flawlessly for different firing angles of non linear load.

**Keywords**—Active power filters (APF), Fuzzy logic controller (FLC), Hysteresis current controller (HCC), PID, Total harmonic Distortion (THD), Voltage source inverter (VSI).

## I. INTRODUCTION

THE major point of concern in present day scenario is quality power. With the advent of thyristors controlled rectifier and inverter circuits are much used in industrial, commercial and research development applications. These circuits along with nonlinear loads will inject considerable harmonics into power system and affect the quality of power drastically which in turn affect the power factor and voltage at the consumer service points [1]-[3]. Conventional passive filters which can be used to control harmonics suffers from problems like resonance, large size, weight and restricted to few harmonic elimination. Static VARs which can be used to meet the above problem suffers from long response time, sometimes produces lower order harmonics themselves which cannot be accepted by fast fluctuating loads [4]-[7]. Active shunt filters play effective role in harmonic elimination in power systems. These filters can be connected in series for voltage harmonic compensation and in parallel for current harmonic compensation. Here the current harmonic problem is treated as it is more severe and complicated. The shunt active filter has the ability to improve the sinusoidal nature of supply current and make it balanced in spite of nonlinear load

Kavala Kiran Kumar is with the Anil Neerukonda Institute of Tecnology and Sciences, Visakhapatnam-531162, India (phone: +919966850546; e-mail: kiran\_kavala.eee@anits.edu.in).

Prof R.Govardhana Rao is with the Anil Neerukonda Institute of Tecnology and Sciences, Visakhapatnam-531162, India.

connected to the system [8]-[12]. Recently, fuzzy logic controllers are used in power electronic system, drive applications and active power filters [13]-[17]. A PI, PID, fuzzy based active shunt filter is proposed [18] but works satisfactorily for diode bridge rectifiers where the firing is fixed at zero. This paper proposes a fuzzy tuned PID controller in conjugation with DQO reference frame transformation technique which works satisfactorily for different firing angle settings of thyristor bridge rectifiers, restricting the harmonic distortion to minimum.

Here PID controller is tuned using fuzzy logic control which sets the  $K_p$ ,  $K_i$ ,  $K_d$  values depending upon firing angle of thyristor bridge rectifier and input rms current. The PID controller along with DQO reference frame transformation technique is used to extract fundamental component of load current and to fix the DC side capacitor voltage of voltage source inverter to a constant value. VSI switching signals are generated from hysteresis band current control techniques. The proposed APF system is tested is tested through MATLAB simulation under different loading conditions.

## II. ADAPTED CONTROL STRATEGIES

### A. PID Controller

Fig. 1 shows the block diagram of the proposed Proportional Integrator Derivative (PID) control scheme of an active power filter. The error  $e = V_{dc,ref} - V_{dc}$  at the nth sampling instant is used as input for PID Controller.

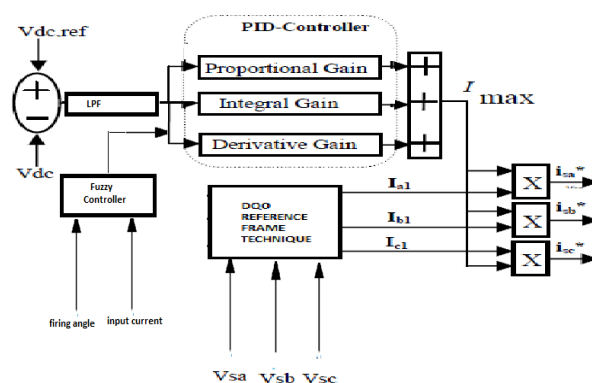

Fig. 1 Block diagram of Fuzzy tuned PID controller

The PID controller is a linear combination of the P, I and D controller. Its transfer function can be represented as given by (1):

$$H(s) = kp + ki + kd(s) \quad (1)$$

where,  $k_p$  is the proportional constant that determines the dynamic response of the Dc-side voltage control,  $k_i$  is the integration constant that determines its settling time and  $k_d$  is the derivative of the error representing the trends. The controller is tuned with proper gain parameters for estimating the magnitude of peak reference current  $I_{max}$  and control the dc-side capacitor voltage of inverter. The peak reference current multiplied with DQO reference frame output determines the desired reference current.

### B. Fuzzy Logic Controller:

Fuzzy logic control is deduced from fuzzy set theory in 1965; where transition is between membership and non-membership function. Therefore, limitation or boundaries of fuzzy sets can be undefined and ambiguous; FLC's are an excellent choice when precise mathematical formula calculations are impossible.

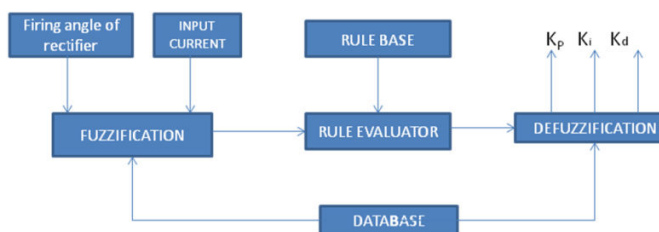

Fig. 2 Block diagram of fuzzy logic control

Fig. 2 shows block diagram of the fuzzy logic control scheme. The firing angle of thyristor bridge rectifier and the input current are sensed and given as input to fuzzy controller.

#### Fuzzification:

Fuzzy logic uses linguistic variables instead of numerical variables. In a control system, error between reference signal and output signal can be assigned as Negative Big (NB), Negative Medium (NM), Negative Small (NS), Zero (ZE), Positive small (PS), Positive Medium (PM), Positive Big (PB). The triangular membership function is used for fuzzifications. The process of fuzzification convert numerical variable (real number) to a linguistic variable (fuzzy number).

#### Rule Elevator:

Conventional controllers like PI and PID have control gains which are numerical values. Fuzzy logic controller uses linguistic variables instead of the numerical values. The basic fuzzy logic controller operation uses the following fuzzy set rules to control the system

AND -Intersection:  $\mu A \cap B = \min[\mu A(X), B(x)]$

OR -Union:  $\mu A \cup B = \max[\mu A(X), B(x)]$

NOT-Complement:  $\mu A = 1 - \mu A(x)$

#### Defuzzification:

The rules of fuzzy logic controller generate required output in a linguistic variable (Fuzzy Number), according to real world requirements; linguistic variables have to be transformed to crisp output (Real number). This selection of strategy is a compromise between accuracy and computational

intensity.

#### Database:

The Database stores the definition of the triangular membership function required by fuzzifier and defuzzifier.

#### Rule Base:

The Rule base stores the linguistic control rules required by rule evaluator (decision making logic). The rules used in this proposed controller are shown in Table I.

TABLE I  
 RULE BASE TABLE

Ce(n) \ e(n)	NB	NM	NS	ZE	PS	PM	PB
NB	NB	NB	NB	NB	NM	NS	ZE
NM	NB	NB	NB	NM	NS	ZE	PS
NS	NB	NB	MN	NS	ZE	PS	PM
ZE	NB	NM	NS	ZE	PS	PM	PB
PS	NM	NS	ZE	PS	PM	PB	PB
PM	NS	ZE	PS	PM	PB	PB	PB
PB	ZE	PS	PM	PB	PB	PB	PB

The output of fuzzy controller gives the corresponding gains  $K_p$ ,  $K_d$ ,  $K_i$  to PID controller, PID controller in turn limits the THD to minimum.

### C. Hysteresis Current Controller (HCC):

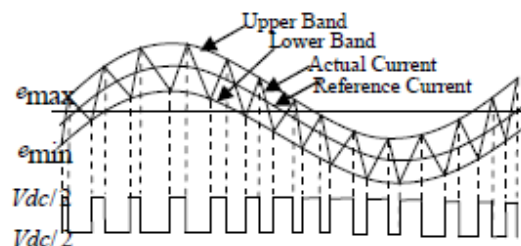

Fig. 3 Diagram of Hysteresis current control

HCC is utilized independently for each phase and directly generates the switching signals for three-phase voltage source inverter. An error signal  $e(t)$  is the difference between the desired current  $i_{ref}(t)$  and the actual current  $i_{actual}(t)$ . If the error current exceeds the upper limit of the hysteresis band, the upper switch of the inverter arm is turned OFF and the lower switch is turned ON. As a result, the current start to decay that is shown in Fig. 3. If the error current crosses the lower limit of the hysteresis band, the lower switch of the inverter arm is turned OFF and the upper switch is turned ON. As a result, the current gets back into the hysteresis band. The switching performance is as given refer to (2).

$$s = \begin{cases} 0, & \text{if } i_{actual}(t) > i_{ref}(t) + h \\ 1, & \text{if } i_{actual}(t) < i_{ref}(t) - h \end{cases} \quad (2)$$

Here the hysteresis band limit  $h=0.5$ . The interface inductor between inverter and PCC suppresses the harmonics caused by the switching operation of the inverter.

#### D. Reference Frame D-Q-O Technique:

Several methods are used to recognize and extract harmonic distortions which are classified as frequency, time and time frequency approaches. Fast Fourier Transform(FFT) [20] and adaptive neural network [19] in frequency domain, synchronous reference frame theory d-q-o (SRF) [21] and instantaneous active and reactive power theory (pqr) [22] in time domain and the other methods such as small wave technique and one-cycle control or separation with suitable digital or analogue filters[23] have wide applications.

In this approach, reference frame algorithm is used due to simplicity in calculation and implementation. Having measured three phase currents in a-b-c orientation, transformed to d-q-o by park equations (3) & (4):

$$\begin{bmatrix} i_d \\ i_q \\ i_o \end{bmatrix} = \sqrt{\frac{2}{3}} \begin{bmatrix} \cos \theta & \cos\left(\theta - \frac{2\pi}{3}\right) & \cos\left(\theta - \frac{4\pi}{3}\right) \\ \sin \theta & \sin\left(\theta - \frac{2\pi}{3}\right) & \sin\left(\theta - \frac{4\pi}{3}\right) \\ \frac{-1}{\sqrt{2}} & \frac{1}{\sqrt{2}} & \frac{1}{\sqrt{2}} \end{bmatrix} \quad (3)$$

$$\theta = \theta_0 + \int_0^t \omega dt \quad (4)$$

Reference frame rotates synchronous with fundamental currents. Therefore, time variant currents with fundamental frequencies would be constant after transformation. However, harmonics with different speeds remain time variant in this frame. Thus, currents would be separate simultaneously to DC and AC parts as given by (5) & (6).

$$i_d = \bar{i}_d + \tilde{i}_d \quad (5)$$

$$i_q = \bar{i}_q + \tilde{i}_q \quad (6)$$

AC part of d axis and whole current in q axis are used for harmonics elimination and VAR compensation. Zero current is produced due to a three-phase voltage imbalance or waveform distortions which have not been considered in this paper.

Finally, compensated currents are determined by adverse park application on q and d axis described by (7) and (8) to be injected to the network after tracing and reconstruction.

$$i_L = i_g + i_{apf} \quad (7)$$

$$\begin{bmatrix} i_{ab} \\ i_{bc} \\ i_{ca} \end{bmatrix} = \sqrt{\frac{2}{3}} \begin{bmatrix} \cos \theta & \sin \theta \\ \cos\left(\theta - \frac{2\pi}{3}\right) & \sin\left(\theta - \frac{2\pi}{3}\right) \\ \cos\left(\theta - \frac{4\pi}{3}\right) & \sin\left(\theta - \frac{4\pi}{3}\right) \end{bmatrix} \quad (8)$$

The peak reference current output of the PID controller multiplied with DQO reference frame output determines the desired reference current.

### III. SIMULATION RESULT AND ANALYSIS

Three phase shunt APLC system is connected in the distribution network at the point of common coupling through

filter inductances and operates in closed loop. The active power filter comprises six IGBTs with freewheeling diodes, a dc capacitor, RL-filter, compensation controller (DQO) reference frame common coupling for technique in conjugation with Fuzzy tuned PID controller) and switching signal generator (hysteresis current controller) is shown in the Fig. 4. The three phase source is connected with the non-linear load.

The instantaneous source current is  $i_c(t) = i_L(t) - i_s(t)$  and the instantaneous source voltage is  $v_s(t) = V_m \sin \omega t$  can be measured.

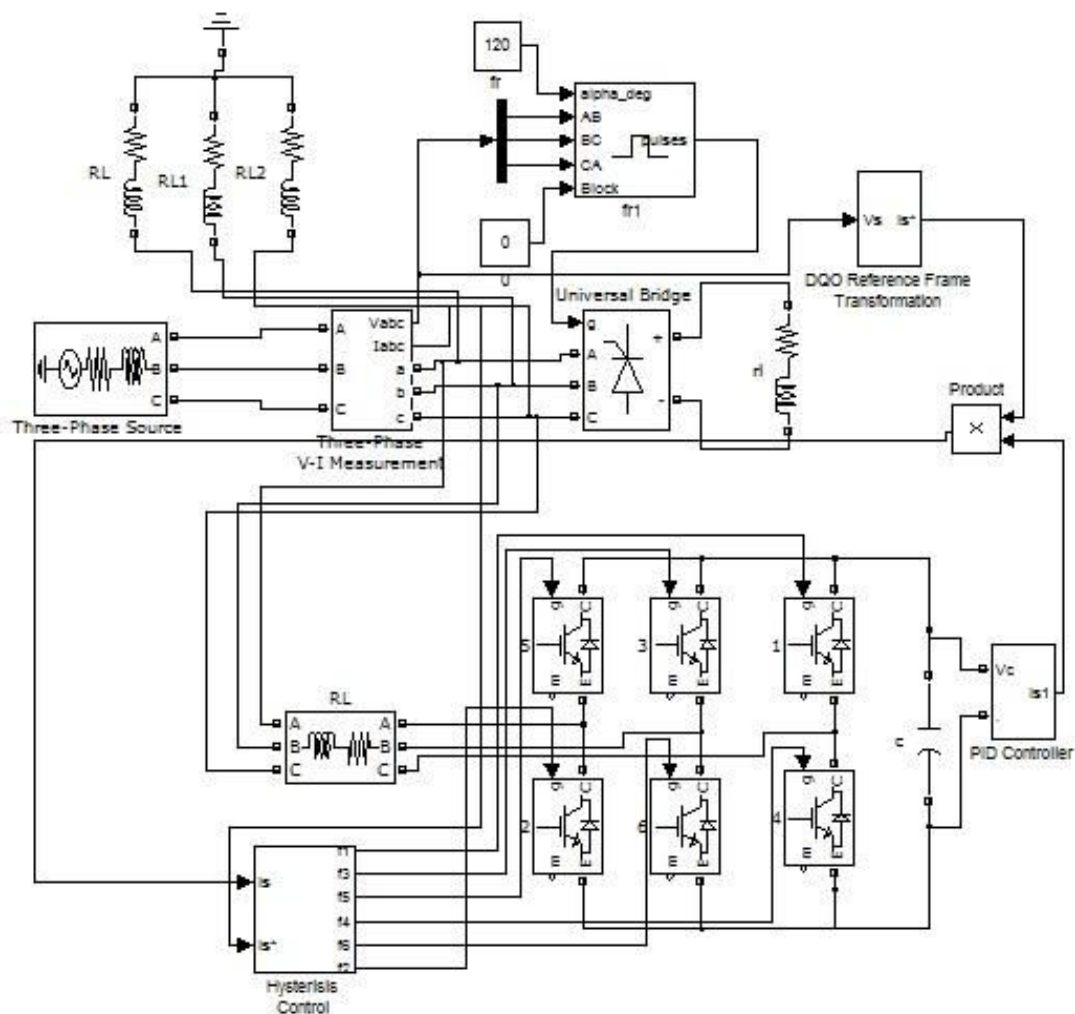

Fig. 4 Proposed Fuzzy tuned PID with DQO reference technique based APF

The nonlinear load current will have a fundamental component and harmonic current components, which can be represented as

$$i_L(t) = \sum_{n=1}^{\infty} \sin(n\omega t + \phi_n) \quad (9)$$

If the active power filter provides the total reactive and harmonic power,  $i_s(t)$  will be in phase with the utility voltage and would be sinusoidal. At this time, the active filter must provide the compensation current.

$$i_c(t) = i_L(t) - i_s(t) \quad (10)$$

Therefore, the active power filter estimates the fundamental component of the load current and compensates the harmonic current and reactive power. The performance of the proposed PI, PID and fuzzy logic control with PLL circuit strategy is evaluated through simulation using Matlab/Simulink power tools. The system parameters values are; Line to line source voltage is 440 V; System frequency (f) is 50Hz; Source impedance of RS, LS is 1 Ω; 0.1 mH; Filter impedance of Rc, Lc is 1 Ω; 1 mH; Unbalanced RL, LL, values are 10 Ω, 50 Ω,

90 Ω and 10 mH respectively.

Thyristor rectifier RL, LL load: 20 Ω; 100 mH; DC side capacitance (CDC) is 1200 μF; Reference voltage (VDC, ref) is 400 V; Power devices used are IGBTs with diodes. The three phase unbalanced RL load is connected in parallel with thyristor bridge rectifier load to the three phase ac mains suppressing the harmonics and reactive power.

The source current without filter is shown in Fig. 5 (a). The source current with filter is shown in Fig. 5 (b) that indicates that the current becomes sinusoidal and active power filter is connected in parallel at the point of The APF compensation current is presented in Fig. 5 (c).

The DC side Capacitance current which is controlled by PID controller is shown in Fig. 5 (d). All the below responses are measured at 120 firing angle of thyristor bridge rectifier.

In Fig. 6 the source current after introducing PI Controller based APF is shown in (c), which reduces the total harmonic distortion to 4.68%, the source current without PI based APF is shown in (b) where the THD is 35%(according to the data quoted in [12]), the compensation current produced by the APF to cancel the harmonic effect is shown in (d). (The nonlinear load considered is Diode Bridge Rectifier).

In Fig. 7 the source current after introducing PID Controller based APF is shown in (a), which reduces the total harmonic distortion to 4.54% which improves the quality further relative to PI based APF, the source current without PID based APF is shown in (b) where the THD is 35%(according to the data quoted in [12]), the compensation current produced by the APF to cancel the harmonic effect is shown in (c). (The nonlinear load considered is Diode Bridge Rectifier).

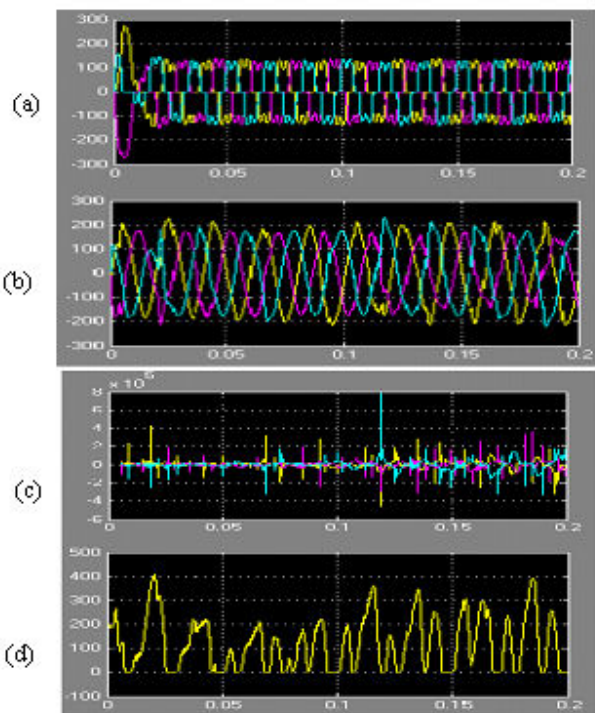

Fig. 5 Fuzzy tuned PID controller based APF simulations under nonlinear and unbalanced load (firing angle of thyristor bridge set at 1200) (a)  $I_s$  without APF, (b)  $I_s$  with APF, (c) Compensation current and (d) DC side capacitor voltage

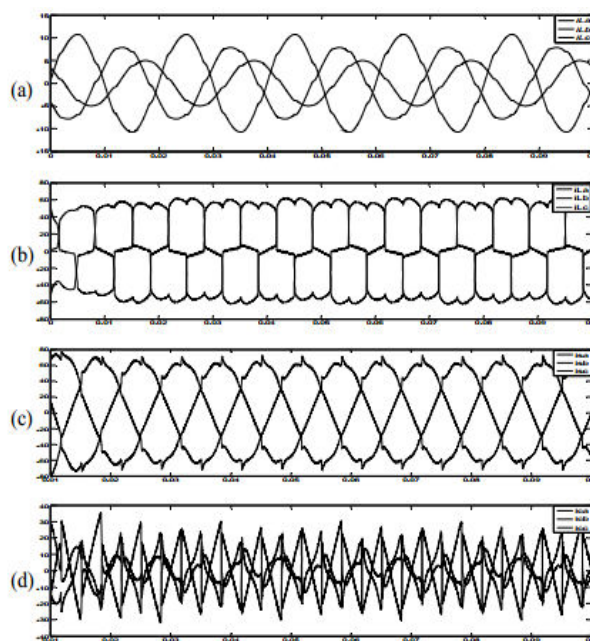

Fig. 6 Simulation results for PI Controller based 3-phase APF with nonlinear and unbalanced loading condition (a) unbalanced RL-load current (b) source current before compensation (c) source current after compensation (d) compensation current

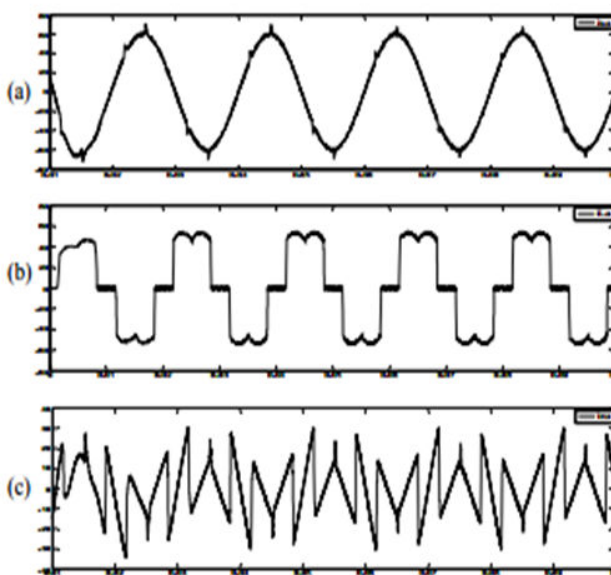

Fig. 7 Simulation results for PID Controller based 3-phase APF with nonlinear and unbalanced loading condition (a) source current after compensation (b) source current before compensation (c) compensation current

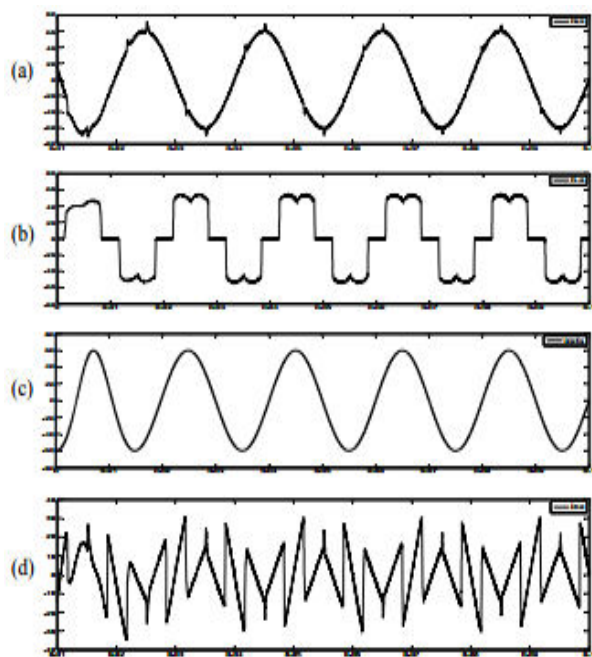

Fig. 8 Simulation results for Fuzzy Controller based 3-phase APF with nonlinear and unbalanced loading condition (a) source current after compensation (b) source current before compensation (c) Reference Current (d) compensation current

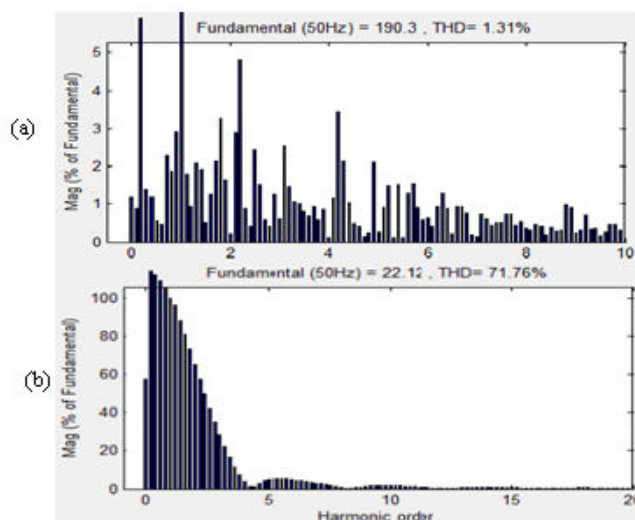

Fig. 9 Fuzzy tuned PID controller based APF: Order of harmonics (firing angle of thyristor bridge set at 1200) (a)  $I_s$  with filter (THD=1.3%) and (b)  $I_s$  without filter (THD=71.76%)

In Fig. 8 the source current after introducing PID Controller based APF is shown in (a), which reduces the total harmonic distortion to 4.41% which improves the quality further relative to PI based APF and PID based APF, the source current without fuzzy based APF is shown in (b) where the THD is 35% (according to the data quoted in [12]), the compensation current produced by the APF to cancel the harmonic effect is shown in (d). (The nonlinear load considered is Diode Bridge Rectifier).

The Fast Fourier Transform (FFT) is used to measure the

order of harmonics at the source current. The magnitude of these harmonics is plotted in Fig. 6 under non-linear with unbalanced load condition.

The THD before and after compensation with fuzzy tuned PI, PID based APF (a firing angle of 120 is set for thyristor rectifier) is presented in Table II

Loading Conditions	Source Current I(s) without APF	Source Current I(s) with APF and fuzzy tuned PID	Source Current I(s) with APF with PI	Source Current I(s) with APF with PID	Source Current I(s) with APF with Fuzzy
Non Linear and Imbalanced load	71.76%	1.31%	4.68%	4.54%	4.41%

The simulation is done for various non-linear and unbalanced load conditions. Fuzzy tuned PID controller with DQO reference frame transformation technique based compensator filter makes the source current balanced and sinusoidal after compensation. FFT analysis of the active filter confirms that the THD of the source current is in compliance with IEEE-519 and IEC 61000-3 harmonic standards.

#### IV. CONCLUSIONS

The simulation study identified that fuzzy tuned PID controller in conjunction with DQO reference technique based APF facilitates improving power quality relative to PI, PID, Fuzzy tuned APFs. The fuzzy tuned PID ensures that the dc-side capacitor voltage is nearly constant with small ripple besides extracting fundamental reference currents for any setting of thyristor bridge firing. The DQO reference frame technique assists the active filter to function even under distorted voltage or current conditions. The shunt APF system is implemented with voltage source inverter and is connected at point of common coupling for filtering the current harmonics and compensating the reactive power. The inverter gate control signals are derived from hysteresis band current controller. The performance of a fuzzy tuned PID controlled APF system is verified and compared under non-linear and unbalanced loads with various parameters that are presented graphically. This approach brings down the THD of the source current that is in compliance with IEEE-519 and IEC 61000-3 required harmonic standards.

#### REFERENCES

- [1] Hirofumi Akagi, Edson hirokazuwatanabe and Mauricio Aredes "Instantaneous power theory and applications to power conditioning" IEEE-press chapter 3-4, pp.19-107, 2007
- [2] Bhim Singh, Kamal Al-Haddad & Amrisha Chandra, "A New Control Approach to 3-phase Active Filter for Harmonics and Reactive Power Compensation"-IEEE Trans. on Power Systems, Vol. 46, No. 5, pp. 133- 138, Oct-1999
- [3] AbdelmadjidChaoui, Jean Paul Gaubert, FatehKrim, Gerard Champenois "PI Controlled Three-phase Shunt Active Power Filter for Power Quality Improvement"- Electric Power Components and Systems, 35, pp.1331-1344, 2007
- [4] Leszek S. Czarnecki "Instantaneous Reactive Power p-q Theory and Power Properties of Three-Phase Systems"- IEEE Trans on Power Vol. 21, No. 1, pp 362-367 Jan- 2006

- [5] Luis F.C. Monteiro, Jose C.C.Costa, Mauricio Aredes, and Joao L.Afonso "A Control Strategy for Unified Power Quality Conditioner" Brazilian power electronics conference-july-2005
- [6] Brod D.M, Novotny D.M "Current control of VSI-PWM Inverter"-IEEE TransonIndustryAppl,Vol.21,pp.562-570, 1985.
- [7] Karuppanan P and Mahapatra, Kamala Kanta "Shunt Active Power Line Conditioners for compensating harmonics and reactive power" IEEE conference on Environment and Electrical Engineering, pp.277 – 280, May 2010.
- [8] Zainal Salam, Tan Perng Cheng and AwangJusoh "Harmonics Mitigation Using Active Power Filter: A Technological Review" ELEKTRIKA, VOL. 8, No. 2, pp.17-26, 2006.
- [9] K. K. Mahapatra, ArindamGhosh and S.R.Doradla "Simplified model for control design of STATCOM using Three-Level Inverter"- IEEE Conference vol. 2, pp. 536-539-1998.
- [10] Salem Rahmani, NassarMendalek and Kamal Al-Haddad "Experimental Design of a Nonlinear Control Technique for Three- Phase Shunt Active Power Filter" IEEE Trans on Industrial Electronics, Vol.57, No.10, pp.3364-3375, Oct-2010.
- [11] Fang ZhengPeng&Jih-Sheng Lai, "Generalized Instantaneous Reactive Power Theory for Three-Phase Power Systems" IEEE Trans. on Inst and Measent, Vol. 45, no. 1, pp293-297 Feb-1996.
- [12] Karuppanan P and Kamala kantaMahapatra "PID with PLL Synchronization controlled Shunt APLC under Non- sinusoidal and Unbalanced conditions" National Power Electronics Conference (NPEC) Proceedings, IIT-Roorkee, June-2010.
- [13] S.K. Jain, P. Agrawal and H.O. Gupta "Fuzzy logic controlled shunt active power filter for power quality improvement"-IEE proc.electr.power.appl,Vol 149, No.5, pp.317-328, Sept-2002.
- [14] S. Saad, L. Zellouma "Fuzzy logic controller for three- level shunt active filter compensating harmonics and reactive power" Electric Power Systems Research, pp.1337–1341 May-2009
- [15] V. S. C. Raviraj and P. C. Sen "Comparative Study of Proportional–Integral, Sliding Mode, and Fuzzy Logic Controllers for Power Converters" IEEE Tran Industry Vol33, No. 2, pp.518-524, Appl-1997.
- [16] Marcelo Godoy Simoes, Bimal K. Bose, and Ronald J. Spiegel "Design and Performance Evaluation of a Fuzzy- Logic-Based Variable-Speed Wind Generation System" IEEE Trans on Industry Applications, Vol.33, No.4, pp.460-465, Aug-1997.
- [17] G.K. Singh, A.K. Singh, R. Mitra "A simple fuzzy logic based robust active power filter for harmonics minimization under random load variation" science direct-Electric Power Systems Research 77 pp.1101–1111, 2007.
- [18] Karuppanan P and Kamala kantaMahapatra" PLL with PI, PID and Fuzzy Logic Controllers based Shunt Active Power Line Conditioners" IEEE Conference pp. 978-1-4244-7781©2010 IEEE
- [19] A. Ametani, "Harmonic reduction in thyristor Converters by harmonic current injection," IEEE Trans8.Power, Appar.Syst.1976, 95, pp.441-449.
- [20] M. Rukonuzzaman and M. Nakaoka, "An advanced active power filter with adaptive neural network based harmonic detection scheme," IEEE power Electronics Specialist cascade, PESC, Vancouver Canada, 2001, pp.1602-1607.
- [21] M. C. Benhabib and S. Saadate, "New Control approach for four wire active power filter based on the use of synchronous reference frame," Elsevier Electric power systems Research 73, 2005, 353-362.
- [22] H. Akagi, Y. Kanazawa, and A. Nahae, "Instantaneous reactive power compensators comprising switching devices without energy storage components," IEEE Trans. Ind. Appl. 1984, 20, pp. 625-630.
- [23] T. Kwan, and K. Martin, "Adaptive detection and enhancement of multiple sinusoids using a cascade of IIR filters," IEEE Trans. Circuits Syst. 1989, 36, pp. 936-947.