

Optical Multicast over OBS Networks: An Approach Based On Code-Words and Tunable Decoders

Maha Sliti, Walid Abdallah, Noureddine Boudriga

Abstract—In the frame of this work, we present an optical multicasting approach based on optical code-words. Our approach associates, in the edge node, an optical code-word to a group multicast address. In the core node, a set of tunable decoders are used to send a traffic data to multiple destinations based on the received code-word. The use of code-words, which correspond to the combination of an input port and a set of output ports, allows the implementation of an optical switching matrix. At the reception of a burst, it will be delayed in an optical memory. And, the received optical code-word is split to a set of tunable optical decoders. When it matches a configured code-word, the delayed burst is switched to a set of output ports.

Keywords—Optical multicast, optical burst switching networks, optical code-words, tunable decoder, virtual optical memory.

I. INTRODUCTION

WITH the constantly increasing multicast applications such as video conferencing, multi-party online games, IPTV and Video on Demand (VoD), which are bandwidth-intensive applications, the optical multicast concept has become increasingly important in order to enhance multicast applications' performance. As a result, optical networks must support multicast traffic type. The optical multicasting allows transferring the information carried by an input wavelength on N different output wavelengths.

Recently, optical code-words present the most promising approach for optical multicasting which allows denoting a multicast group in optical networks. However, the optical code-words based multicasting approach has mainly two issues: node's complexity and optical multicasting scalability.

In the frame of this work, we present an optical multicasting approach based on optical code-words in OBS networks.

Thus, we are interested on the optical multicast process and we suppose that the multicast tree is already established. Our approach associates, in the edge node, an optical code-word to a group multicast address. In the core node, a set of tunable decoders are used in order to send a traffic data to multiple destinations based on the received code-word.

The use of code-words, which correspond to the combination of an input port and a set of output ports, allows implementing an optical switching matrix. At the reception of

Maha Sliti is with the Communication Networks and Security Research Lab, University of Carthage, Tunisia (e-mail: maha.sliti@supcom.rnu.tn).

Walid Abdallah is with the Communication Networks and Security Research Lab, University of Carthage, Tunisia (e-mail: ab.walid@gmail.com).

Noureddine Boudriga is with the Communication Networks and Security Research Lab, University of Carthage, Tunisia (e-mail: nab@supcom.rnu.tn).

a burst, it will be delayed in an optical memory and its associated code-word will be split to a set of tunable optical decoders. When it matches a configured code-word, the delayed burst is switched to a set of output ports.

The key contributions of the proposed approach with respect to the previously published research are:

1. The proposed multicast process is performed at the optical layer by transforming the conventional addressing schemes to an addressing mechanism based on optical code-words. Indeed, the multicast concept is based on a pattern matching process on the received code-words using a set of tunable optical decoders.
2. We propose an all optical multicast module using an optical buffer that avoids O/E/O conversion of bursts which allows the multicast process to be performed at very high bit rates.
3. The proposed optical multicast approach is network scalable in terms of number of traffics, group sizes and overhead. Indeed, code-words are mapped to multicast group addresses in the edge node which optimizes the end-to-end code-words associated to a burst.

The rest of the paper is organized as follows. Section II presents the related work. Section III presents the association between bursts and optical code-words. The optical multicast capable core node design is given in Section IV. Simulations and experimental results are given in Section V. Finally, Section VI concludes the paper.

II. RELATED WORK

The multicasting concept, illustrated by Fig. 1, allows one source to simultaneously transmit data packets to multiple destinations. A route is structured as a tree where the source is the root and the destinations are leaves. At each intermediate node, the received burst is duplicated and transmitted on all interfaces that lead to leaves. Authors are responsible for obtaining any security clearances.

Multicasting can be performed more efficiently in the optical domain by supporting the simultaneous transmission of data traffic from source to multiple destinations without O/E/O conversion. The proposed optical multicast techniques include wavelength routing and optical label switching (OLS).

In optical multicast using wavelength routing [1]-[3], data will be switched to one or more outgoing wavelengths according to the incoming wavelength that carries it. In other words, a wavelength needs to be dedicated to each branch of a multicast tree. Consequently, this approach presents a scalability issue due to the scarcity of wavelength resources as well as the complexity of wavelength routing.

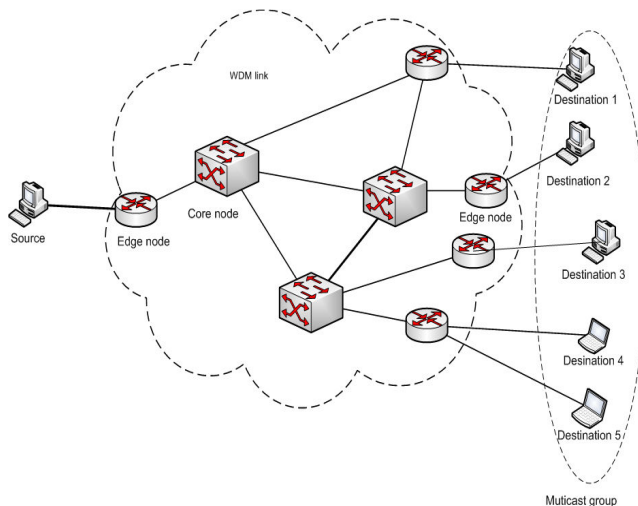

Fig. 1 Multicasting concept

In optical label switching networks (OLS) [4], [5], there is mainly two approaches forwarding decision to intermediate optical core nodes:

1. Label swapping: At each core node, the old optical label is extracted, and a new label is generated and added to the high bit-rate optical packet. Therefore, apart from making a switching/forwarding decision based on the incoming packet label, the core node also needs to generate a new label and attach it to the optical packet. The length of the labels is determined by the actual required bit-length for each core node to make a forwarding decision.
2. Label stripping (end to end): No new label generation functionality is required at each core node which reduces the core node complexity. The edge nodes insert the end-to-end labels. The length of the end-to-end label is determined by the total bit-length of all the local labels for every core node along the pre-defined light path. For large optical networks, the stripping approach may lead to long label fields.

Currently, optical multicast based on employing optical code-words [4], [5] is a promising approach. In the literature, several optical multicast approaches based on code-words were proposed. In [4], authors propose an optical multicast-capable packet switch network based on OC-label switching based on a multiport encoder and decoder which allow respectively generating and processing the optical-code labels. In this approach, the proposed decoders cannot be dynamically configured before the arrival of data units, and code-words must be previously set in the intended decoders. In [5], authors present a Packet switching and forwarding approach based on swapping short local labels instead of locating the global Internet protocol (IP) addresses. This approach requires that apart from making a switching decision based on the incoming packet label, the core node also needs to generate a new label and attach it to the optical packet.

In the frame of this work, we propose a network scalable optical multicast approach based on code-words. The scalability of our approach is achieved by mapping a code-word to an IP multicast address in the edge node. Therefore,

we will not need to affect a different code-word for each node. The proposed multicast process is performed at the optical layer based on code-words and a set of tunable decoders which allows the multicast process to be performed at very high bit rates. The set of decoders are dynamically reconfigurable at the reception of a code-word which is incorporated in the burst header. It is worthy to note that although in this work we considered the optical burst switching technique to show the feasibility of our multicast approach, it can be easily extended to the optical packet switching paradigm.

III. BURSTS AND CODE-WORD ASSOCIATION

In this section, we present the mapping between bursts and code-words in the edge node. Furthermore, we describe the code-word generation process.

A. Mapping Bursts and Code-Words

The proposed optical multicast approach allows the multicast of a burst to a group of nodes in the backbone network. In the edge node, a code-word is associated to the top of each multicast burst. A received traffic data, in the edge node, contains a multicast group address (e.g. IP multicast address) which will be mapped to a code-word. Therefore, for each multicast group address in this range formed by a sequence of p bits, a set of 2^p code-words are generated and ordered starting from the smallest to the largest code-word value.

In the edge node, a code-word and a label are considered as follows:

- The multicast group address is mapped to a code-word (e.g. multicast IP address).
- A label identifies whether the burst is unicast or multicast.
- The BHP (Burst Header Packet) contains the code-word and the label.
- The top of the burst contains the code-word which is treated in the optical layer.

Therefore, at the reception of the BHP in the core node, if the label identifies a multicast traffic, a decoder will be dynamically configured with the received code-word in order to allow the received burst to be sent to multiple destinations. The proposed multicast capable core node architecture will be detailed in the next section.

B. Code-words Generation Process

Optical code-words should be orthogonal and can be presented as a vector of integer. For this purpose, the considered generation process is based on the lattice point theory [7] and it performed as follows:

Consider a $m \times k$ integer lattice $L = \mathbb{Z}_m \times \mathbb{Z}_k$ which elements are labeled by points from the set $V = \{1, 2, \dots, mk\}$. Using a simple linear mapping function defined as:

$$l: L \rightarrow V, \quad l(x, y) = mx + y + 1 \quad (1)$$

The codewords are represented as lines connecting points of the rectangular integer lattice. The subset of points are referred to as lines, and the code spaces are defined as the sets of lines of different slopes. A line with a slope S , where $0 \leq s \leq m-1$, starting at the point (i, j) , contains the following set of points:

$$\{(i; j + (simodm) : 0 \leq i \leq k-1; 0 \leq j \leq m-1\} \quad (2)$$

Thus, for every slope s , the m codewords that can be obtained are $v = \{v_1, \dots, v_m\}$, where $v_j = \{mi + j + (simodm) + 1; 0 \leq i \leq k-1\}$, for every $0 \leq j \leq m-1$. The length of these codewords is $n = mk$ and their weight is k . It is noteworthy that, for every slope, the codewords obtained through the aforementioned process are orthogonal. According to this reasoning, every codeword v_j can be represented as an integer vector $v_j = (v_j^0; v_j^1; \dots; v_j^{k-1})$, where $j \in \{1; 2; \dots; mk\}$ where v_j^i is the position of ones in the optical code j .

IV. OPTICAL MULTICAST ARCHITECTURE

In this work, we propose multicast capable core node architecture adapted to OBS networks. In this section, we present the design of the proposed multicast capable core node architecture based on a set of tunable decoders.

A. Multicast Capable Core Node Architecture

The proposed multicast capable core node architecture is illustrated by Fig. 2. At the reception of the burst header, the multicast traffic identifier unit extracts the label in order to identify whether the traffic is multicast or unicast.

In the case of multicast traffic, the received code-word, which identifies a multicast node group, will be extracted and dynamically configured in a decoder by the control unit. At the reception of its corresponding burst, this last will be delayed in a virtual optical memory (VOM) based on optical delay lines, that has developed in [9], and the multicasting module processes the received codeword and split it to a set of decoders. Each decoder was configured to match a specific codeword indicating a multicast group. If the received code-word matches a configured code-word in a decoder, a pulse activates the optical switch gate (OSG) and allows the switch to forward the delayed burst, to a set of output ports allowing to reach the destination core nodes in a multicast group. Therefore, a code-word corresponds to an input port and a set of output ports.

B. Multicast Capable Core Node Architecture

The set of decoders, which are the main component of the multicasting module, allow the matching of codewords optically without the O/E/O conversion. The design of a tunable decoder, proposed in [8] to implement optical filtering technique, is given in Fig. 3.

In each loop, we inject the optical pulse which will be confined in the fiber until it performs a number of rounds

needed to place it in the positions of a '1' bits in the optical code. It is obvious that the number of ones in the code sequence determines the number of optical loops needed. Consequently, we could easily control and modify the codeword by controlling the number of rounds performed by the optical signal in every optical loop.

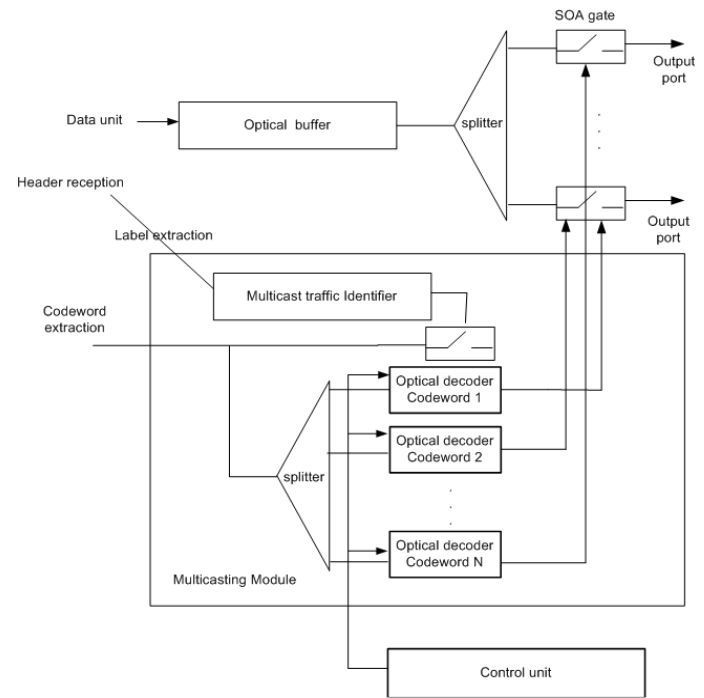

Fig. 2 Optical multicast core node design

Unlike classical techniques, such as fixed length Optical Delay Lines and Fiber Bragg Gratings, in which modifying optical codes needs a physical intervention, our approach allows soft based controlling of the optical codewords by considering a control unit even if it uses Fiber Bragg Gratings.

A codeword is considered as an integer vector of $\$k\$$ elements that presents the positions of ones in the codeword.

The following are codeword examples: $v_{11} = (1,7,13)$; $v_{12} = (2,8,14)$; $v_{13} = (3,9,15)$, which respectively correspond to the sequence of codes $v_{11} = (1000001000001)$, $v_{12} = (01000001000001)$ and $v_{13} = (001000001000001)$.

Thus, an optical codeword is composed of optical pulses transmitted in specific bit intervals that correspond to positions of ones in the code sequence. This can be achieved by considering an on-off keying technique and modulating the label by a Gaussian optical pulse signal and a Mach-Zehnder modulator.

The tunable decoder generates an optical pulse on the receipt of a valid codeword that matches the configured codeword. The decoding operation is performed by delaying optical pulses that compose the received codeword until they superpose in the last bit interval. In order to confine the pulse in the optical delay line, each loop is composed of the following components:

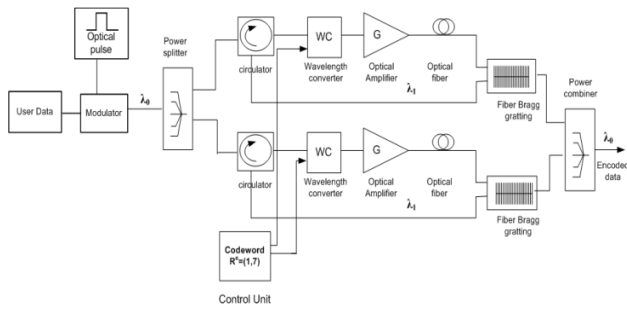

Fig. 3 Tunable optical decoder architecture

- Circulator: used to re-inject the optical signal in the loop after its reflection by the fiber bragg grating.
- Wavelength Converter: Used to shift the original wavelength of the optical signal λ_0 to λ_1 that is in the reflection band of the fiber bragg grating until the needed delay, which is represented by the number of rounds, is elapsed. When it is the case, the pulse wavelength will be reconverted to λ_0 to get out from the loop. This operation is commanded by a control unit. Thus, the decoder can be easily reconfigured for a new codeword sequence simply by modifying the number of rounds.
- Erbium-Doped Fiber Amplifier (EDFA): Compensates the attenuation in the optical delay line. The gain of this component will depend of the number of rounds performed by the optical signal.
- Fiber Bragg Grating (FBG): Reflects signals having wavelengths in its reflection band. Obviously, to delay the optical pulse, the original wavelength λ_0 must be out of the reflection band and λ_1 must be in the reflection band of the FBG.
- Optical Delay Line (ODL): It is a portion of optical fiber where the optical signal propagates until the configured number of loops is performed. The length of the loop L corresponds to a delay of the bit period.
- Control Unit: Represents the main component. It controls the number of rounds that a pulse must perform in the loop by delivering a synchronous signal to pilot the wavelength converter. When the optical label enters the loop, it generates a signal to command the conversion of the input optical signal wavelength from λ_0 to the FBG reflective wavelength λ_1 . At the exit instant, the control unit sends another signal to the wavelength converter to restore the input wavelength λ_0 of the optical signal. If R_j^d is the vector that represents the number of rounds n configured in each controlled loop in the decoder, it will be equal to the following: $R_j^d = (n-v_j^{k-1}, n-v_j^{k-2}, \dots, n-v_j^0)$, with j is the index of the codeword, and n is the length of the code in number of bits and it is equal to $k*m$.

V. BURST HEADER PACKET (BHP) MANAGEMENT

We suppose that the Just-Enough-Time (JET) [6] signaling protocol is used in our OBS network. Each BHP is transmitted an offset time ahead of the burst transmission. The BHP contains the length of the associated burst and the offset time

between the BHP and the burst. Upon arrival of the BHP, the arrival and departure times of the burst can be determined. Thus, an outgoing wavelength channel can be reserved for the burst for precisely its duration.

With this technique, an output wavelength is reserved for a burst just before the arrival of the first bit of the burst. The proposed multicast approach in OBS networks introduces additional delays affecting the offset time separating the control packet (Fig. 4) and its corresponding burst. Thus, a procedure in the way the offset time is established is given. Indeed, at the reception of the BHP, a capable multicast core node, must: 1) identify whether the traffic corresponds to a unicast or multicast traffic which corresponds to the label matching delay, 2) extracts the code-word from the BHP and configures it in a decoder when the received traffic corresponds to a multicast traffic.

Consequently, a novel field "Latency" will be added to the BHP which corresponds to the accumulated delays in the capable multicast core nodes in the path:

$$\text{Delay}_i = \text{labelMatchingDelay}_i + \text{codeWordConfigurationDelay}_i$$

where i is a multicast core node in the path.

At the reception of the BHP by a destination, it will be resent to the source edge node in order to estimate the new offset time based on the following formula:

$$\text{newOffset} = \alpha \text{oldOffset} + (1 - \alpha) (\text{oldOffset} + \sum \text{delay}_i)$$

where α is a real in $]0,1[$ managed in the network level.

Label (unicast/multicast)	Code-word	Offset time	Latency	Routing information	Burst description in terms of segments
---------------------------	-----------	-------------	---------	---------------------	--

Fig. 4 BHP structure

The proposed optical multicasting approach requires a delay separating the header and its corresponding burst. In fact, during this delay, the received codeword in the header, which indicates the multicast core node group, must be configured in a tunable decoder. Thus, the application of our multicasting approach to Optical switching Packet network will require additional delay compared to OBS networks. Therefore, in OPS networks, the packet control header is typically sent together with data packet along the same path which requires delaying the packet in a buffer during the decoder configuration and the codeword matching before the forwarding of the packet. Thus for OPS networks, we can suppose that the decoder configuration is performed only when a new header is received and not for all received headers which optimizes significantly the additional delays.

VI. SIMULATIONS AND EXPERIMENTAL RESULTS

In this section, we assess the performance of the proposed optical multicast approach. To this purpose, we developed a simulation model based on Matlab tool that considers a network connected in a random topology where each link has a fixed number of wavelengths and link loads are mutually

independent. For each link, the generated bursts are considered as poisson arrivals.

The multicast traffic blocking ratio is assessed in terms of the maximum wavelength number for different traffic sizes and it is illustrated by Fig. 5. We can notice a decrease in the traffic blocking rate for all traffic sizes when increasing the maximum number of wavelengths. Furthermore, we denote that more the traffic size is growing, more the losses are closer. Therefore, for traffic size of 600 bursts and more, the traffic blocking rate is almost constant. This blocking is caused by the effect of the VOM size on the traffic. Indeed, when we generate a number of bursts that is many times greater than the available wavelengths, the VOM will not be able to handle these bursts due to the increasing contention.

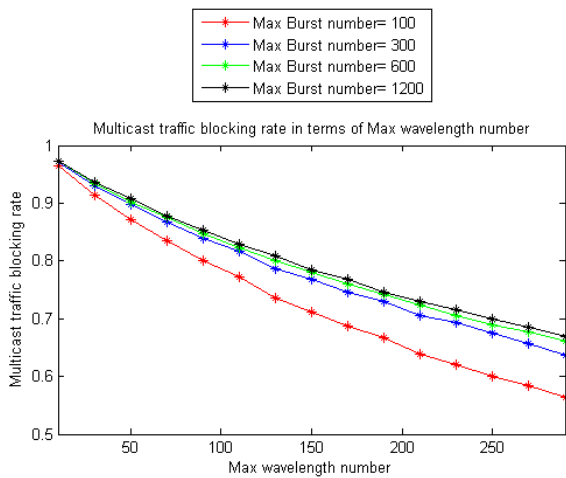

Fig. 5 Multicast traffic blocking ratio in function of Max Wavelength number

Furthermore, we evaluate the performance of the proposed optical multicast approach by assessing its effect on the optical signal quality during the multicast process and the additional multicast delays. We notice in Fig. 6 that the global multicast delays spent in the multicast capable core nodes in the path, which is called "latency", increases in function of the tree depth. The maximum delay corresponds to the time spent by the burst from one node to another waiting for multicasting while circulating in the VOM. Indeed, at the reception of a multicast burst, a code-word will be extracted from the burst and split to a set of tunable decoders, which requires a code-word matching delay. The accumulated delays through the multicast path give the global latency resulting from the burst multicast process in each core node in the path. Since we assume poisson arrivals, it is easy to see a linear curve in Fig. 6.

Fig. 7 illustrates the decrease of the optical signal quality in terms of the tree deepness. We notice that the multicast latency implies the signal quality degradation. Therefore, the buffering delay of the burst in the optical buffer (VOM) cannot exceed a maximum delay in order to avoid the unacceptable degradation of SNR that implies the information loss in the optical signal due to the effect of attenuation and

dispersion [9]. As a result, the global signal quality decreases in function of the multicast path length in the network as presented in Fig. 7.

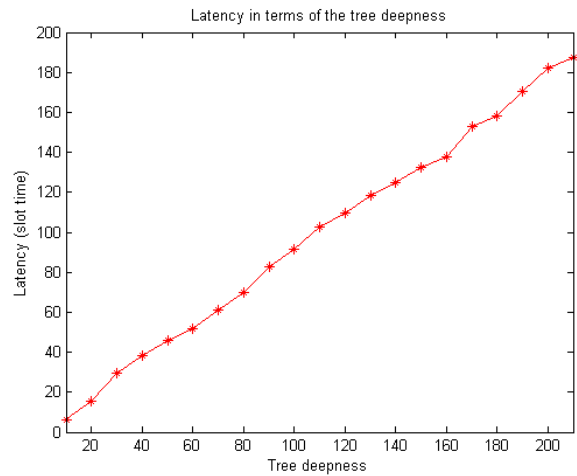

Fig. 6 Latency in terms of the tree depth

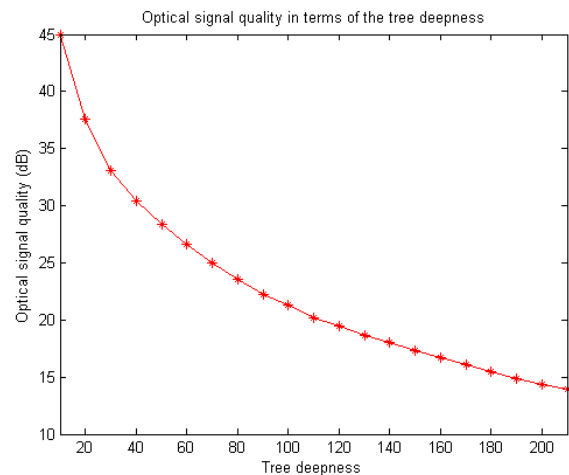

Fig. 7 Optical signal quality in terms of the tree depth.

The optical signal degradation resulting of the turn number in the VOM is evaluated based on the SNR and Q parameters of the output signal. Equation (3), established in [9], represents the logarithmic Q factor expression after i turns in the loop that is deduced from the SNR_i, and where B₀ is the optical bandwidth of the photodetector and B_c is the electrical bandwidth of the receiver filter.

Equation (4), given in [9], establishes the SNR expression after i turns in the loop, where: P_{in} is the input signal power, SNR_{ssb} is the SSB signal to noise ratio, η_{sp} is the ratio of electrons in higher and lower states, h is the Plank's constant, Δ_f is the bandwidth that measures the noise figure and G_{EDFA} is the EDFA gain.

$$Q_i (dB) = 20 \log \sqrt{SNR_i \frac{B_0}{B_c}} \quad (3)$$

$$SNR_i = \frac{P_{in} \cdot SNR_{SSB}}{i \eta_{sp} \cdot h \cdot \nabla f \cdot SNR_{SSB} (G_{EDFA} - 1) [2\lambda_0 - \Delta\lambda(i+1)] + iP_{in}} \quad (4)$$

VII. CONCLUSION

In this work, we have proposed an optical multicasting approach based on optical code-words. Our approach associates, in the edge node, an optical code-word to a group multicast address. In the core node, a set of tunable decoders are used to send a traffic data to multiple destinations based on the received code-word. The use of code-words, which correspond to the combination of an input port and a set of output ports, allows to implement an optical switching matrix.

The proposed multicast process is performed at the optical layer by transforming the conventional addressing schemes to an addressing mechanism based on optical code-words.

Indeed, the multicast concept is based on a pattern matching process on the received code-words, using a set of tunable optical decoders. Furthermore, our approach uses an optical buffer and avoids O/E/O conversion of bursts which allows the multicast process to be performed at very high bit rates.

Moreover, in this work, we have developed a network scalable approach in terms of traffic number, group size and overhead. Indeed, code-words are mapped to multicast group addresses in the edge node which optimizes the end-to-end code-words associated to a burst.

REFERENCES

- [1] M. Ali and J. Deogun, "Power-efficient design of multicast wavelength-routed networks" *IEEE J. Sel. Areas Commun.*, vol. 18, 2000, pp. 1852-1862.
- [2] Q. Huang and W.-D. Zhong, "Wavelength-routed optical multicast packet switch with improved performance," *J. Lightw. Technol.*, vol. 27, 2009, pp. 5657-5664.
- [3] Y. Zhou and G. S. Poo, "Optical multicast over wavelength-routed WDM networks: a survey," *Opt. Switching Netw.* vol. 2, 2005, pp. 176-197.
- [4] S. Yoshima, N. Wada, G. Cincotti, T. Miyazaki, and K. Kitayama, "Multicast-capable optical-code label packet switch: Proposal and its experimental demonstration," *Optical Switching and Networking*, vol. 5, 2008, pp. 29-37.
- [5] N. Yan, A. Alcaide, J. M. D. Mendinueta, E. Tangdionga and A. M. J. Koonen, "Traffic performance evaluation of optical label switching nodes with optical layer multicast," *Proc. SPIE 6783, Optical Transmission, Switching, and Subsystems V*, November 19, 2007.
- [6] C. Qiao and M. Yoo, "Just Enough Time (JET): a high-speed protocol for burst traffic in optical networks", in *IEEE/Lasers and Electro-Optics Society Conference*, pp.26-27, Aug 1997.
- [7] Ivan B D. and Bane V., "Novel combinatorial construction of optical orthogonal codes for incoherent optical CDMA system," *Journal of Lightwave Technology*, vol. 21, 2003, pp 1869-1875.
- [8] N. Boudriga, M. Sliti, W. Abdallah, "Optical code-based filtering architecture for providing access control to all-optical networks (Invited)," *International Conference on Transparent Optical Networks (ICTON)*, Coventry, England, 2012.
- [9] S. Batti, M. Zghal, N. Boudriga, "A New All-Optical Switching Node Including Virtual Memory and Synchronizer," *JNW*, vol. 5, 2010, pp. 165-179.