



ESICC 2023 – Energy efficiency, Structural Integrity in historical and modern buildings facing  
Climate change and Circularity

## Application of a retrofit system to improve the seismic and energy performances of RC framed buildings

Gabriele Fichera<sup>a</sup>, Veronica Guardo<sup>a\*</sup>, Giuseppe Margani<sup>a</sup>, Carola Tardo<sup>a</sup>

<sup>a</sup>Department of Civil Engineering and Architecture, University of Catania, 95123, Catania

---

### Abstract

The need to renovate the existing building stock in earthquake-prone countries is now widely recognized. In this framework, this paper aims at investigating an innovative technology for the seismic, energy and architectural renovation of RC framed buildings. This technology combines the seismic resistance provided by steel trusses with the thermal performance of wood-based panels, which are both applied to the outer building envelope.

In this paper, the proposed system is applied to a pilot building located in the city of Bucharest, in Romania, to examine its effectiveness and replicability. The pilot building is a five-storey apartment block located in a suburban neighborhood of the city and representative of many coeval buildings in Bucharest that are energy-intensive and earthquakes-prone since they were built before the enforcement of effective seismic and energy efficiency standards. The proposed retrofit methodology involves designing wood-based prefabricated panels and steel trusses according to criteria of structural strengthening and energy efficiency, standardization in manufacturing process, fast installation, and architectural integration. Furthermore, the parametric modeling in BIM environment of the above-mentioned components enables controlling their size, quantity, manufacturing, cost, and arrangement on the building façade to optimize the construction and installation processes.

© 2024 The Authors. Published by Elsevier B.V.

This is an open access article under the CC BY-NC-ND license (<https://creativecommons.org/licenses/by-nc-nd/4.0>)

Peer-review under responsibility of the ESICC 2023 Organizers

*Keywords:* energy efficiency; seismic performance; prefabricated wood-based panels; architectural integration; BIM methodology;

---

---

\* Corresponding author. Tel.: +39 346 364 0007

E-mail address: [veronica.guardo@unict.it](mailto:veronica.guardo@unict.it)

## 1. Introduction

In the past, little attention has been paid to the issues of environmental sustainability and structural safety in the building construction sector. Indeed, most of the building stock in the European seismic countries is highly energy-intensive and earthquake-prone since it was built before the enforcement of effective energy and seismic codes. It is also often characterized by low architectural quality and relevant construction weaknesses. This is mainly caused by the natural decay of the materials over the years, but also by the originally use of poor-quality materials by construction companies whose intent was to minimize costs and maximize profits. Hence, building renovation is today a major priority to achieve the main EU targets of environmental sustainability and structural safety. The most frequent approach for anti-seismic and energy-efficient renovation involves combining the traditional retrofit techniques in an additive way. Nevertheless, these traditional techniques have relevant limits, which are mostly related to seismic upgrading interventions, such as: i) high costs; ii) long time for implementation; iii) high occupants' disturbance; iv) significant demolition and reconstruction interventions; v) large quantities of demolition waste.

In this framework, a recent research topic concerns the potential use of external steel braced structures, commonly named exoskeletons, as holistic renovation strategy for the concurrent energy and architectural renovation of the buildings (Takeuchi et al., 2006), (Labò et al., 2016), (Ferrante et al., 2016), (Marini et al., 2017), (D'Urso et al., 2019). Indeed, the addition of steel exoskeleton is an effective technique for the seismic upgrading of RC framed buildings (Rahimi et al., 2020), which has the advantages of reducing cost and time for implementation as well as occupants' disturbance thanks to the application from the outside of the building and the high level of prefabrication.

To this research context belongs the Horizon 2020 project e-SAFE (Energy and Seismic AFFordable rEnovation solutions) that aims at developing innovative, low-invasive, environmental-friendly technological solutions for seismic, energy, and architectural renovation of RC framed buildings. One of the e-SAFE solutions provides to combine a 3D steel exoskeleton (named e-EXOS) with prefabricated insulating panels (named e-PANEL) to be applied to the external envelope of the building.

The combined use of these two components has several advantages. On the one hand, the e-EXOS allows to force a uniform distribution of the storey drifts along the height of the building and avoid the formation of soft storey collapse mechanisms (Fig. 1a). Hence, it reduces the drift demand of the existing structure caused by earthquakes, thus preventing its collapse. Additionally, the trusses can be also provided with Buckling Restrained Braces (BRBs) at the base, which supply an increase of the dissipation capacity of the structure. On the other hand, in terms of energy performance, the e-PANEL aims at increasing the thermal resistance of the walls, and thus the energy efficiency of the building (Fig. 1b). Moreover, its new cladding layer contributes to renovate the new building's architectural image (Bosco et al., 2023).

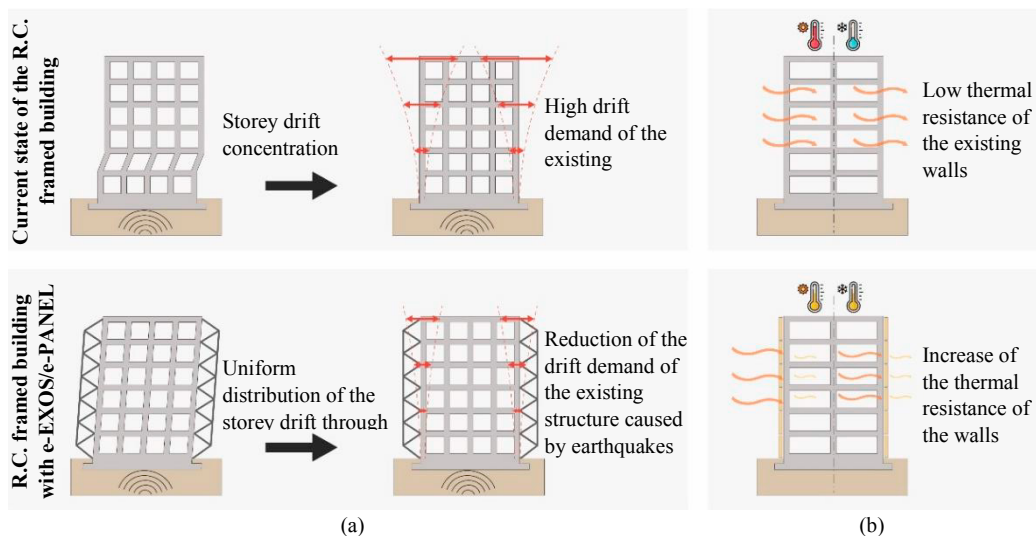

Fig. 1 Concept of the e-EXOS/e-PANEL system: (a) seismic performance of the e-EXOS; (b) energy performance of the e-PANEL.

Given the multidisciplinary nature of the e-SAFE technological system, an integrated management is fundamental to control the architectural, constructive, mechanical electrical plumbing (MEP), sustainability-related and economic aspects. Therefore, it was decided to use a Building Information Modelling (BIM) approach, which allows to control all the phases of the project, reducing dissimilarities and incongruities between the various design stages. In this context, this paper describes the e-EXOS/e-PANEL system and its validation through the retrofitting design of a pilot building.

## 2. Methods

The proposed methodology is divided in 9 phases (Fig. 2). The first four steps (yellow and blue portions in Fig. 2) take place simultaneously. Specifically, the phases 1 and 3 provide analyzing the current state of the building, by involving firstly the laser scanner survey of the building façades and the data transfer to BIM, and then filtering the information required for the specific intervention, e.g. the wall finishing data, since the components are applied from the outside. On the other hand, the phases 2 and 4 provide designing the e-SAFE components and their BIM parameterization (see Section 3.1). Indeed, one of the primary objectives of the e-SAFE system is the replicability of the retrofit intervention to different boundary conditions (geometric, climatic, structural, etc.). Consequently, the building components of the system need to be parametrically modelled to easily vary their characteristics. Therefore, a BIM methodology is employed to create a set of *parametric families* for both e-PANEL and e-EXOS and for each of the metalwork elements of the e-EXOS wall connection. Each family parameter needs to be a *shared parameter* so that is not associated to one *family* but can be accessed by different files and users. Moreover, the phases concerning the application of the e-SAFE building components in the BIM model (phase 5) and the construction details (phase 6) are highlighted in green (see Section 3.2). Finally, the methodology includes the last three more steps: the production of the e-SAFE building components (phase 7), their installation (phase 8) and follow-up maintenance (phase 9).

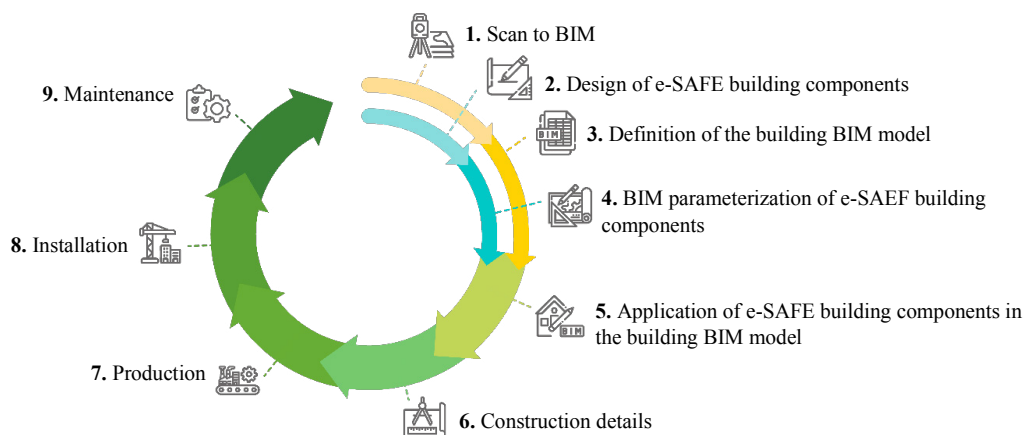

Fig. 2 Stages of the proposed retrofit methodology.

## 3. Results

### 3.1. Design and BIM parameterization of e-SAFE building components

Along with the building renovation “Scan to BIM” and “Definition of the BIM level of information needed” phases, the proposed methodology focuses on the “Design of e-SAFE building components”. As already mentioned in Section 1, the building components described in this paper are the e-PANEL and e-EXOS developed within the e-SAFE project (Fig. 3a). The e-PANEL is a prefabricated and insulating wood-based panel to be applied to the existing outer walls of the building. This new building skin integrates a thermal-acoustic insulation layer and, if needed, also new high-performing windows and sun shading devices. In addition, it can integrate many cladding materials that contribute to

the restyling of the building's architectural image. Fig. 3b shows the main e-PANEL stratification, which is an update of the preliminary configuration that has been designed within the project and reported in (Barbagallo et al., 2018). This new stratification can guarantee: i) adequate mechanical performance; ii) thermal transmittance compliant with limits imposed by law; iii) watertightness and airtightness; iv) vapor permeability and moisture resistance; v) fire-protection; vi) quick installation. Essentially, the e-PANEL is made of a lightweight wooden frame that integrates thermal-acoustic insulation. On the internal face, it is confined by marine plywood boards. On the external face, it is confined by a non-combustible cement-based board to ensure the panel adequate fire protection. The e-PANEL also includes a waterproof vapor-open membrane to avoid condensation issues and rainwater leakage. The panel is completed by a cladding layer, separated from the watertight layer by a ventilated air cavity. The e-PANEL is connected to the existing RC beams at the top through commercial angle steel brackets. Specific sliding connectors are provided at the bottom; in case of earthquakes, these connectors allow the panel to slide together with the upper RC beam, avoiding or reducing the panel damage.

Instead, the e-EXOS steel truss has a structural role. It provides for a dry installation and is a reversible seismic upgrading technique that does not interrupt the building operativity during its installation.

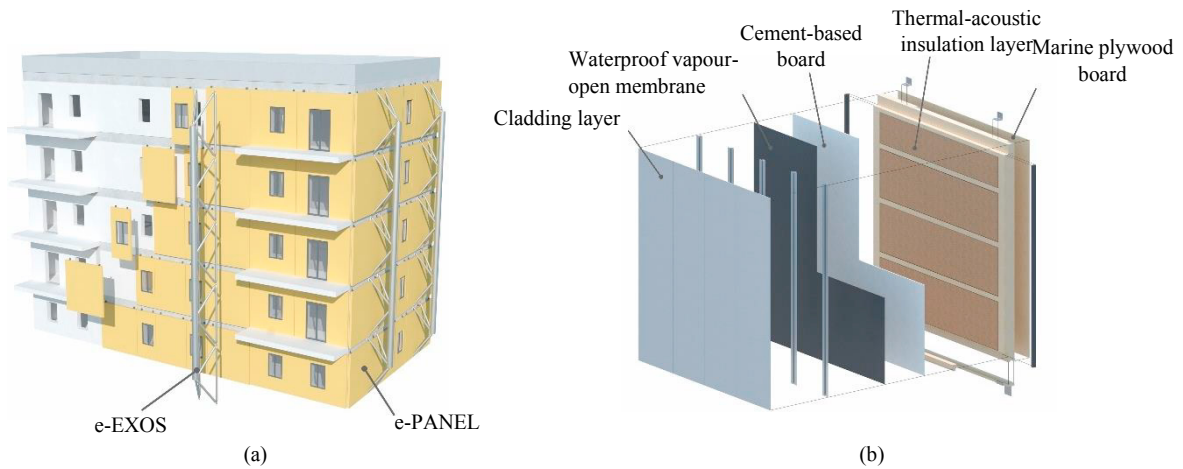

Fig. 3 (a) The e-EXOS system in combination with the e-PANEL solution; (b) e-PANEL stratification.

During the development phase, critical points have been detected at the connection node between e-EXOS, e-PANEL, and the existing RC beams as well as in the space between two panels of consecutive storeys (Fig. 4a). Specifically, the main issues that occur were referred to: i) the different sliding movements of the components during earthquake; ii) the thermal bridges at the beam level; iii) the watertightness of the components.

The sliding movements of the components differ due to the different sliding of the building decks during earthquakes. This issue is solved by configuring the connection node as shown in Fig. 4b: all the elements highlighted in orange will oscillate together with the beam to which they are fixed. To this extent, the sliding movement of the upper panel does not interfere with the e-EXOS wall connection. However, this solution creates a thermal bridge at the level of the RC beam. This issue is solved by designing a horizontal joint cover with an insulation layer, as shown in Fig. 5a-5b. The main wooden frame panel of the joint cover is prefabricated, while the following other layers are assembled on-site: i) a fiber-reinforced concrete panel; ii) a waterproof membrane; iii) a finishing layer separated from the watertight layer by a ventilated air cavity (to dry rainwater infiltrations and winter moisture). Additionally, the joint cover is connected to the bottom panel, while shaped strips made possible the sliding movements on the upper panel connection. To protect the panel from rainwater, the proposed solutions include a ventilated air gap behind the finishing layer (Fig.5c) and the folding of a waterproof membrane towards the edge of the panel. Moreover, the overlapping of the waterproof membrane on the upper and bottom panels ensures waterproofing at the horizontal joints (Fig. 5d). A steel plate and a membrane ensure waterproofing at the truss connection. Details of the whole solution applied to a pilot building are shown in section 3.2.

Different geometric variables (i.e. distances, lengths, diameters, angles, radiuses, and reciprocal positions) of the e-PANEL and e-EXOS have been associated with specific parameters through the Revit software in order to ensure

the replicability of the retrofit intervention to different boundary conditions; furthermore, various parameters have been concatenated by using specific mathematical formulas. Each of these specific parameters is classified into *shared parameters groups* and then reported in tables related to a particular project domain, i.e. sizing, construction, assembly, visibility, materials. Hence the BIM *families* are applied within the BIM model of the building (Fichera and Guardo, 2022). An application example of a retrofit intervention by the e-EXOS and e-PANEL is analysed in Section 3.2, with reference to the selected residential pilot building.

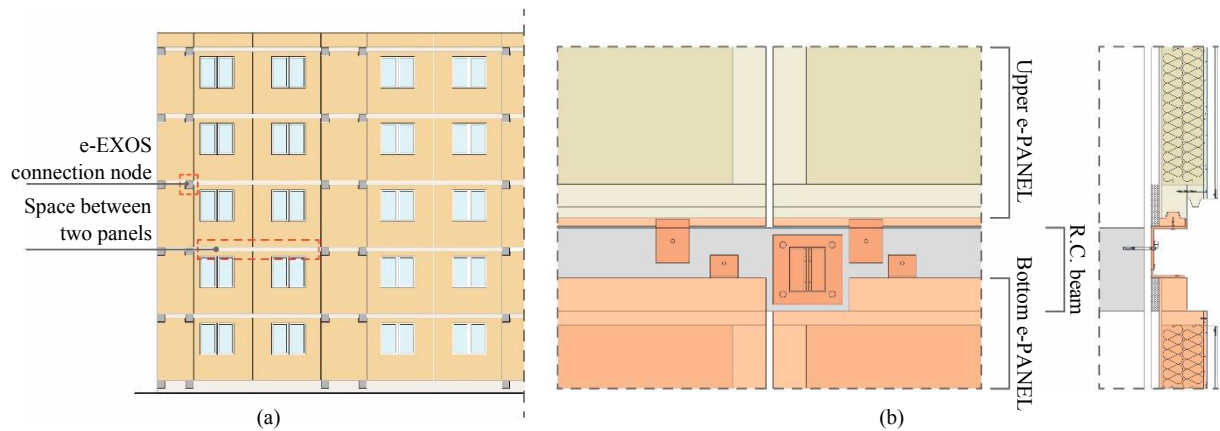

Fig. 4 (a) Main critical connection nodes; (b) configuration of nodes for different sliding movements of the components.

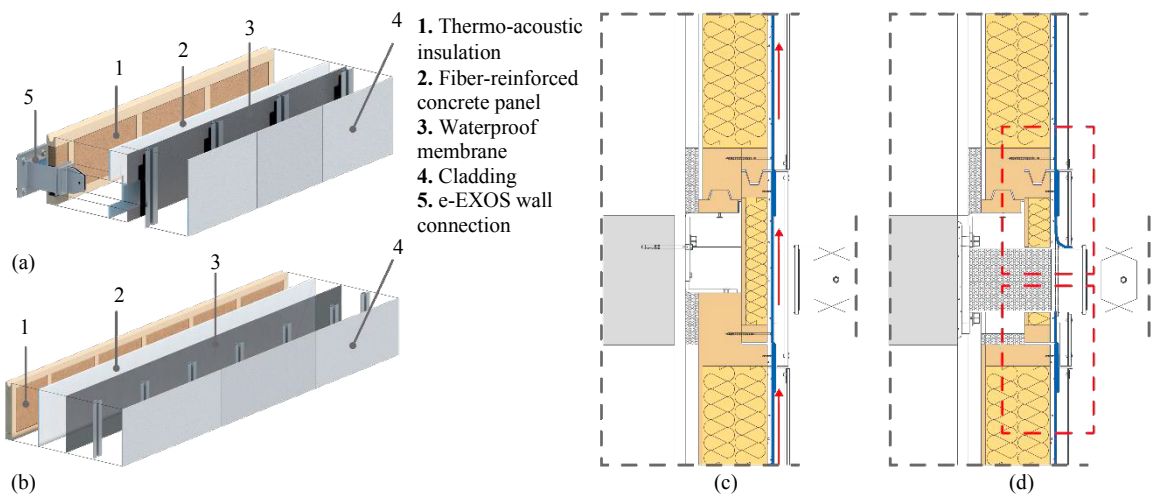

Fig. 5 (a-b) Horizontal joint cover with and without the e-EXOS wall connection; (c) detail of the e-PANEL ventilated air cavity (vertical section); (d) detail of the overlapping of the waterproof membrane (vertical section).

### 3.2. Application of e-SAFE building component on the BIM model of a pilot building

The pilot building (Fig. 6) is a five-storey apartment block built in the 1970s and located in a suburban neighborhood of the city of Bucharest, in Romania. It is representative of many coeval residential blocks in Bucharest in terms of structural deficits, poor energy efficiency and low architectural quality.

The pilot has a rectangular floor plan with a total area of around 1700 m<sup>2</sup> and a small and narrow central court. It has five storeys and a total height of 14 m. Each floor has four 80-m<sup>2</sup> apartments. The building has a RC framed structure, with frames mainly oriented along the longitudinal direction, resulting in low seismic performance in the orthogonal one. The infill walls are 35-cm thick and made of solid bricks; therefore, they have a non-negligible



structural role. The architecture image is quite anonymous; the only identifying feature is the striped color variation along the two main fronts.

The infill walls are not insulated. The intermediate floors and flat roof are characterized by RC slabs (23-cm thick), without thermal insulation too. The windows have PVC frames, double-pane gazing and no external sun shading systems. The thermal transmittance values (U) of external walls, windows and roof floor are quite high, namely 1,8 W/m<sup>2</sup>K, 2.7 W/m<sup>2</sup>K and 1.2 W/m<sup>2</sup>K, respectively.



Fig. 6 Eastern front of the pilot building.

The design of the proposed retrofit system started with the laser scanner survey of the building fronts (Fig. 7) and was followed by the scan-to-BIM process of the building data. Then, specific configurations of the e-EXOS trusses and e-PANELs have been conceived in order to: i) ensure the retrofit system remarkable performance in terms of anti-seismic protection, energy and technological efficiency and architectural integration; ii) maximize the standardization of the prefabricated elements to optimize the production process and ensure the replicability of the retrofit interventions under different boundary conditions; iii) make the installation process fast and efficient.

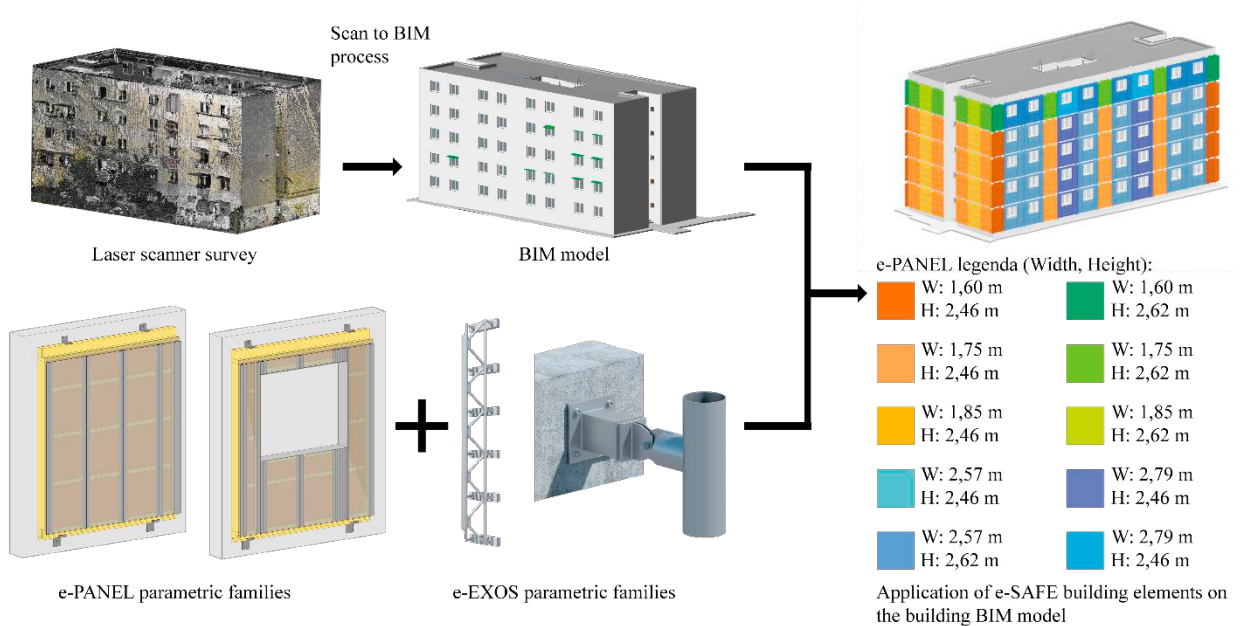

Fig. 7 Scheme of the first steps of the proposed methodological process applied to the pilot building.

The e-EXOS trusses consist of a set of rods and nodes, which are manufactured and assembled off-site so that each truss is made of three pre-assembled portions that are bolted to each other on-site afterwards. Each truss is anchored to the existing building perimetral beams and a new foundation, which is separated from the existing one. The beam-truss connections are designed to prevent the horizontal relative displacements between the existing building and the truss (Fig. 8), while the vertical ones are not constrained thanks to a vertical slotted hole in the anchor plate. On the other hand, the foundation-truss one is a pinned connection. In this way, in the event of earthquake each truss rigidly rotates in the plane perpendicular to the building façade by transmitting a set of forces to the existing structure that reduces the concentration of drift in few storeys.

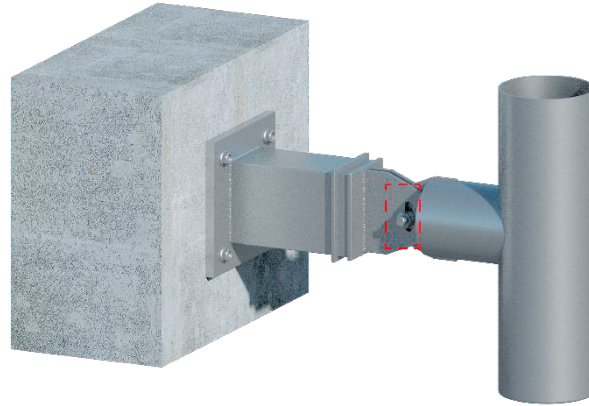

Fig. 8 Beam-truss connection.

As regard the e-PANEL, it is designed according to the main stratification described in Section 3.1.

The panels are 210-mm thick and include (Fig. 3b): i) 10-mm thick marine plywood board; ii) 150-mm thick wood-fiber thermal-acoustic insulation layer ( $\lambda = 0,038 \text{ W m}^{-1} \text{ K}^{-1}$ ); iii) 12,5-mm thick cement-based board; iv) waterproof vapour-open membrane; v) 30-mm thick ventilated air cavity; vi) 6-mm thick porcelain cladding layer. The above stratification ensures the outer walls a U-value of  $0,29 \text{ W m}^{-2} \text{ K}^{-1}$ .

The standardization of the panels was achieved by maximizing the number of elements with the same height and width in order to optimize the production and installation processes. Specifically, ten type of panels have been design, that mostly differ in the width size (Fig. 7).

Fig. 9 shows the rendering of building after the application of the proposed seismic and energy retrofitting solution.



Fig. 9 Rendering of the pilot building at post-renovation state.

#### 4. Conclusions

This paper analyses the application methodology of a retrofit intervention for RC framed buildings that combines the use of a structural exoskeleton made of 3D steel trusses (called e-EXOS) with prefabricated, wood-based insulating panels (called e-PANEL) to be applied to the external envelope of the building.

The proposed methodology first involves surveying the current state of the building by laser scanning of the façades and then transferring the building data to BIM. Next, the e-SAFE building components are designed, and BIM parameterized. Then, the e-SAFE parametric components are applied to the BIM building model. Overall, the e-EXOS and e-PANEL technologies are the result of a design method that integrates multidisciplinary knowledge to ensure the retrofit system remarkable performance in terms of seismic resistance, energy and technological efficiency, as well as architectural integration. Furthermore, working in a BIM environment and parameterizing all the e-SAFE building components allow optimizing the design retrofit process.

The first steps of the proposed retrofit methodology were validated through the application on a pilot building. This allowed to verify the possibility of parameterizing the e-SAFE technologies to ensure replicability of the retrofit intervention under different boundary conditions, in relation to geometric, climatic and structural requirements.

The next steps in the methodological process will involve the production of the e-SAFE components, their installation and maintenance.

#### Acknowledgements

The authors would like to thank the members of the multidisciplinary research team of the University of Catania involved in the development of the e-EXOS and e-PANEL components: Francesca Barbagallo, Melina Bosco, Sebastiano D'Urso, Edoardo Michele Marino, and Grazia Maria Nicolosi.

This paper was carried out in the framework of the following project: "Energy and seismic affordable renovation solutions" (e-SAFE) project, which has received funding from the European Union's Horizon 2020 research and innovation programme under grant agreement No. 893135 (neither the Executive Agency for Small-and-Medium-sized Enterprises - EASME - nor the European Commission is in any way responsible for any use that may be made of the information it contains).

#### References

- Barbagallo F, Bosco M, Marino EM, Rossi PP. Seismic retrofitting of braced frame buildings by RC rocking walls and viscous dampers. *Earthquake Engineering and Structural Dynamics* 2018, 47, 2682–2707
- Bosco M, D'Urso S, Margani G, Marino E.M, Nicolosi G.M, Tardo C. Application potentials of a 3D exoskeleton technology combined with prefabricated panels to renovate the modern building stock", in F. Fatiguso, F. Fiorito, M. De Fino, E. Cantatore (eds.), *Colloqui.AT.e 2023. In transition: challenges and opportunities for the built heritage*, Edicom Edizioni, Monfalcone.
- D'Urso S, Cicero B. From the Efficiency of Nature to Parametric Design. *A Holistic Approach for Sustainable Building Renovation in Seismic Regions. Sustainability* 2019, 11, 1227.
- Ferrante A, Mochi G, Predari G, Badini L, Fotopoulou A, Gulli R, Semprini GA. European Project for Safer and Energy Efficient Buildings: Pro-GET-onE (Proactive Synergy of integrated Efficient Technologies on Buildings' Envelopes). *Sustainability* 2018, 10(3), 812.
- Fichera G, Guardo V. Progettazione mediante metodologia BIM di un intervento di riqualificazione con tecnologia e-SAFE, Master's degree thesis, 2022.
- Labò S, Passoni C, Marini A, Belleri A, Camata G, Riva P, Spacone E. Diagrid Solutions for a Sustainable Seismic, Energy, and Architectural Upgrade of European RC Buildings. *Proceedings of the XII International Conference on Structural Repair and Rehabilitation*, Porto, Portugal, 2016.
- Marini A, Passoni C, Belleri A, Feroldi F, Preti M, Metelli G, Riva P, Giuriani E, Plizzari G. Combining seismic retrofit with energy refurbishment for the sustainable renovation of RC buildings: a proof of concept. *Eur J Environ Civil Eng* 2017: 1–21.
- Rahimi A, Maheri MR. The effects of steel X-brace retrofitting of RC frames on the seismic performance of frames and their elements. *Eng. Struct.* 2020, 206, 110149.
- Takeuchi T, Yasuda K, Iwata M. Studies on Integrated Building Facade Engineering with High-Performance Structural Elements. *IABSE Symp. Rep.* 2006, 92 (4), 33–40.