

Flame Stability and Structure of Liquefied Petroleum Gas-Fired Inverse Diffusion Flame with Hydrogen Enrichment

J. Miao, C. W. Leung, C. S. Cheung, and R. C. K. Leung

Abstract—The present project was conducted with the circumferential-fuel-jets inverse diffusion flame (CIDF) burner burning liquefied petroleum gas (LPG) enriched with 50% of hydrogen fuel (H_2). The range of stable operation of the CIDF burner in terms of Reynolds number (from laminar to turbulent flow regions), equivalence ratio and fuel jet velocity of LPG of the 50% H_2 -LPG mixed fuel was identified. Experiments were also carried out to investigate the flame structures of the LPG flame and LPG enriched H_2 flame. Experimental results obtained from these two flames were compared to fully explore the influence of hydrogen addition on flame stability. Flame heights obtained by burning these two kinds of fuels at various equivalence ratios were compared and correlated with the Global Momentum Ratio (GMR).

Keywords—Flame stability, hydrogen enriched LPG, inverse diffusion flame.

I. INTRODUCTION

AS one of the cleanest gaseous fuels, LPG is widely applied in domestic, commercial and industrial applications. The portable and user-friendly features of LPG make it an ideal alternative of nature gas in many regions. Also, with a high volumetric heating value, LPG earns its special place in energy supply chain. Comparing with LPG, hydrogen fuel has the advantages in terms of diversified supply and extremely low pollutant emissions [1]. Having the smallest molecule among all substances [2], H_2 has a very high flame speed. A low percentage of H_2 in the fuel is therefore expected to significantly affect the flame performance and stability range of the fuel mixture.

Gas-fired diffusion flames are widely used in commercial and industrial applications because of their wide range of stable operation, but they generally have inferior pollutant emission characteristics comparing to their counterpart: gas-fired premixed flames. The inverse diffusion flame (IDF) burner applied in the present investigation consists of a big central circular air jet surrounded by several co-axially arranged

smaller circular fuel jets. Because of its ability to entrain surrounding air, an IDF maybe classified as a partially premixed flame and more able to produce clean combustion. Stability of IDF burning methane/air mixture was studied by Clausing et al. [3]. Sze et al. [4] found that the IDF was stable in a wide range of operation conditions and the flame length could be easily controlled by separately adjusting the air and fuel supplies. It was also observed that the air/fuel mixing was intense and the flame temperature was higher in the IDF, but the high flame temperature might lead to higher NO_x emissions [5]. Ng et al. [6] observed from comparing with premixed gas-fired flames, that the IDF was able to achieve comparable or even higher heating efficiency. Dong et al. [7]-[8] confirmed that a higher heat transfer rate could be achieved with the IDF due to the augmented turbulence level originating from the flame neck of IDF. The NO_x emission characteristics of IDF were investigated by Partridge et al. [9] with the laser-saturated fluorescence technique.

The reviews show that IDF burning gaseous hydrocarbon fuels is preferable for many applications due to its high combustion efficiency and heat transfer performance. But the toxic gaseous pollutant emissions of IDF such as CO, HC and NO_x must be greatly reduced to safeguard human health and meet the stringent pollution emission requirements especially for domestic applications. Besides, the lean flammability limit of most gaseous hydrocarbon fuels poses a limit on the stability of fuel-lean combustion of IDF. One prospective method to solve this stability problem is to add suitable proportion of hydrogen fuel into the gaseous hydrocarbon fuel. By lowering down the carbon content in the fuel, it is expected that the pollutant emissions related to burning carbon can be reduced directly. In addition, due to the very special properties of hydrogen: extremely high specific heat, burning velocity and adiabatic flame temperature [10]-[12], combustion and heating performances of the IDF burner are expected to be significantly improved.

Currently, hydrogen-hydrocarbon blend fuels have received much attention due to their potentials to improve flame stability of the fuel-lean combustion, enhance the heating performance and reduce the green house gas CO_2 and other pollutant emissions related to burning carbon such as CO, HC and soot particles. Rortveit et al. [13] found that the addition of hydrogen to natural gas or methane might lead to an increase of NO_x emissions if the burner was not specially designed for low NO_x emissions. The addition of hydrogen led to a rise in the flame temperature, which might result in an increase of the thermal

J. Miao is with the Department of Mechanical Engineering, The Hong Kong Polytechnic University, Hong Kong, China (e-mail: harmony_mj@126.com).

C.W. Leung is with Department of Mechanical Engineering, The Hong Kong Polytechnic University, Hong Kong, China (e-mail: mmcw1@polyu.edu.hk).

C. S. Cheung is with Department of Mechanical Engineering, The Hong Kong Polytechnic University, Hong Kong, China (e-mail: mmcsc@polyu.edu.hk).

R.C.K. Leung is with Department of Mechanical Engineering, The Hong Kong Polytechnic University, Hong Kong, China (e-mail: mmrleung@polyu.edu.hk).

NO formation. In addition, the NO formation caused by burning hydrogen-hydrocarbon fuels was found to be higher than that caused by the pure hydrocarbon flames. Guo et al. [13] examined the effect of hydrogen addition on the NO_x emissions in ultra-lean premixed flames. When the equivalence ratio was kept constant, the addition of hydrogen was found to enhance the NO emissions and reduce the formation of NO_2 and N_2O monotonically.

Comparing with the gaseous pollutant emissions, particulate emissions are usually received less attention in burning gaseous hydrocarbon fuels. Due to the growing concern of indoor air quality in enclosed compact household environments, several recent studies focused on the particulate emissions. Guo et al. [14] found that domestic cookers were major source of airborne particles in household environments and should be treated as a potential high health risk. Wagner et al. [15] found that the average diameter of the emitted particles was around 7 nm for partially premixed flames and around 10 nm for non-premixed flames, which constituted a serious concern for human health as they were able to penetrate deep into a human's respiratory system [16]. Opinions on the effects of hydrogen addition on particulate emissions from hydrocarbon flames, especially diffusion flames, were rather divergent. Burbano et al. [17] suggested a decrease in particulate emissions by adding hydrogen but Cozzi and Coghe [18] observed an increase.

Premixed flames such as Bunsen type, which are commonly used in house, have been intensely investigated. As premixed flames are stable in a very narrow range, applications of the flames are rather limited. To solve the problem in applying premixed flame, several scientists started to work on inverse diffusion flames (IDFs). With separately supplied air and fuel, inverse diffusion flame can be stable over a relatively wide range. High velocity air jet delivered from center of the flame entrains surrounding fuel jets, to form a flame base [19]. Entrainment between air/fuel jets can create a premixed zone, which enhances the mixing of air and fuel. Different from premixed flames, diffusion flames do not possess some fundamental fuel characteristics, such as burning velocity [20]. Researchers are mainly focused on the flame thermal performance and flame structure related aspects. Mehesh measured the stability of LPG-IDF in a back-step burner by varying the air jet velocity at a constant fuel jet velocity until flame blow-off was observed [21]. Sobiesiak and Wenzel correlated air-fuel jet velocity ratios with visible flame length of methane-IDFs [22]. Similar research had been done by Kiran to observe the relationship between flame length and Froude number in simple LPG jet diffusion flame [23]. Dong et al. did a series of experiments to investigate the structure features of LPG-IDF, including sizes of inner flame cone, flame base and outer flame layer regarding to different equivalent ratios and Reynolds numbers [7].

In this paper, observations about flame stability range, flame height and flame structure of LPG-IDFs and H_2 -LPG-IDFs are described. Detail explanation of experimental data is also discussed.

II. EXPERIMENTAL SYSTEM

A special designed IDF burner was used in this project. The burner consists of two main parts: a burner head and a burner chamber. As shown in Fig. 1, the brass burner head has a central channel, which is 5.5 mm in diameter for air supply. The twelve smaller channels surrounding the central air channel are 2 mm in diameter, and are designed for fuel supply. The smaller fuel channels are arranged 12 mm from the central air channel. The burner chamber is in cylindrical shape, and is used for fuel mixing. Several layers of wire nets are placed inside the burner chamber to ensure the uniform mixing of fuels. A copper tube connected with the central air channel penetrates through the burner chamber bottom to obtain air supply. Fuels (LPG and H_2) are supplied through the opening on the lower part of burner chamber. With the help of wire nets, fuels mixture is supplied evenly out from the twelve fuel channels, and is surrounded by ambient air. At the same time, high velocity air jet from the central air channel exerting a drag force on the fuel jets to form an inverse diffusion flame as shown in Fig. 2.

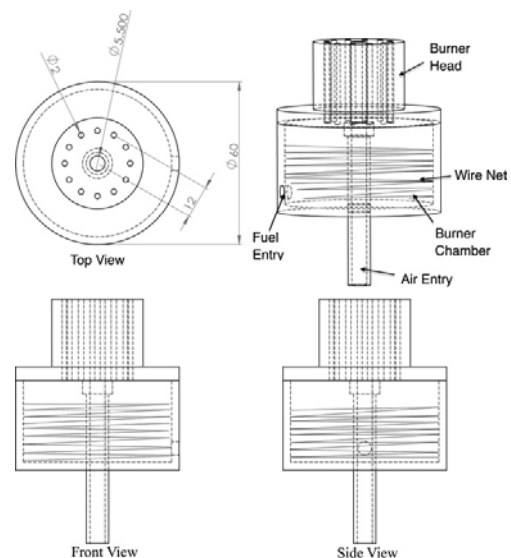

Fig. 1 IDF Burner Construction

Two fuels were used in this study: liquefied petroleum gas (LPG) and hydrogen (H_2). Commercial grade LPG was used, which contains 30% (vol) propane, and 70% (vol) butane, and applies the tested hydrogen has a purity of 98%. LPG and hydrogen were controlled by regulators and measured by flow meters, and were delivered into the burner chamber to form uniform mixture naturally.

Open flame structures were observed by vision. A ruler with 1mm accuracy was placed on the left-hand side of burner. Ten photographs were taken for each flame, and average reading of flame heights as observed from photographs was recorded as final result. A high-resolution digital camera was used. To ensure clear flame outline and data accuracy, the camera was operated at light sensitivity (ISO)=200, f-number=1/2.8 and exposure time=1s.

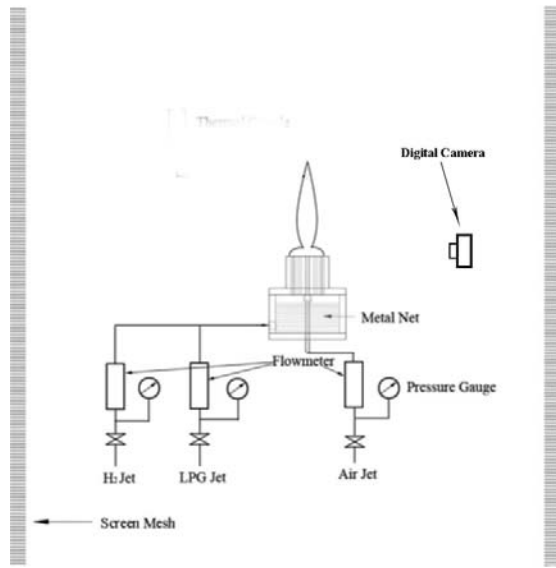

Fig. 2 Experimental System

To prevent flame from interference by outside air current, a net screen was used to surround the burner. The net screen provided shelter on three sides of the burner, with an opening to facilitate operation. And a 100 liter/s air extractor was placed 1 meter away from the system to purify indoor air. All the data were collected under standard condition.

TABLE I
 NOMENCLATURE

Symbol	Quantity	Unit
d	diameter of air jet exit	mm
Φ	equivalence ratio	
GMR	global momentum ratio	
H	flame length	mm
$H_2\%$	volumetric percentage of hydrogen in fuel mixture	%
ρ_{air}	air density in 1 atm and 25 °C	kg/m ³
Re	reynolds number of air jet	
μ_{air}	air viscosity in 1 atm and 25 °C	kg/s·m
V_{air}	air jet flow rate	liter/min
v_{air}	air jet velocity	m/s
V_{fuel}	fuel mixture jet flow rate	liter/min
v_{fuel}	fuel mixture jet velocity	m/s

III. ASSUMPTIONS AND METHOD FOR DATA HANDLING

In this study, several flame parameters were considered, including Reynolds Number (Re), equivalence ratio, volumetric hydrogen percentage, flame length and air/fuel jets velocities.

As velocity of the air jet is much higher than that of the fuel jet, the flame performance is dominated by the air jet velocity. Therefore only Reynolds number of air jet was considered in calculation. To analyze flame stability of the LPG-IDF, flames were investigated under $Re=500-7000$, and experiments used to explore flame structures were performed at $Re=1500$ and $Re=3000$ respectively. Calculation of air jet Reynolds number was evaluated as:

$$Re = \frac{\rho_{air} v_{air} d}{\mu_{air}} \quad (1)$$

Equivalence ratio of fuel and air jet indicating fuel lean, fuel rich or stoichiometric condition was obtained in this study to evaluate flame stability and flame length. Equivalence ratio was calculated as:

$$\Phi = \frac{(\frac{v_{air}}{v_{fuel}})_{stoichiometric}}{(\frac{v_{air}}{v_{fuel}})_{actual}} \quad (2)$$

LPG fuel enriched with 50% hydrogen fuel was the main fuel supplied in this study. Comparison was made with those obtained with LPG fuel under same Re and equivalence ratio. The percentage of hydrogen fuel was calculated as:

$$H_2\% = \frac{V_{H_2}}{V_{H_2} + V_{LPG}} \times 100\% \quad (3)$$

A non-dimensional parameter called Global Momentum Ratio (GMR) was adopted to correlate with flame length in this paper. Mahesh and Mishra introduced GMR to relate air-fuel jet momentum transfer and flame length of LPG-IDF[24]. In this project, correlation between GMR s and flame lengths of LPG and 50% hydrogen-enriched LPG were conducted under $Re=1500$ and $Re=3000$. GMR was defined as:

$$GMR = \Phi \left(\frac{v_{fuel}}{v_{air}} \right) \quad (4)$$

IV. RESULTS

A. Flame Stability

As burning velocity is not strictly applicable to IDF, therefore flame stability range is a very important characteristic in IDF application and simulation. There were twelve sets of experiments performed under Re varying from 500 to 7000 to investigate the minimum percentage of LPG in the air-fuel mixture required for stable flame. During the experiment, air jet flow rate was fixed, and then the LPG flow rate was slowly reduced until the flame blew off. The operation was repeated to ensure data accuracy.

Fig. 3 LPG-IDF's Stable Boundary Regarding to Re and Fuel Flow Velocity shows the LPG-IDF stability range as defined by Re and fuel flow velocity.

The lower limit of fuel jet velocity exponentially ascends with Re . The required flow velocity grows steeply when Re is larger than 5000. Since the airflow rate was used in this study for Re calculation, the result can be translated as the relationship between air jet velocity and lower limit of fuel jet velocity.

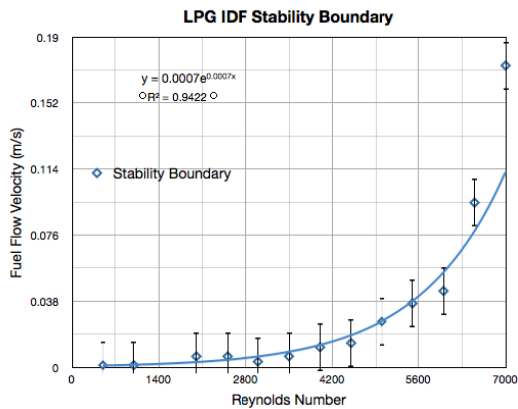

Fig. 3 LPG-IDF's Stable Boundary Regarding to Re and Fuel Flow Velocity

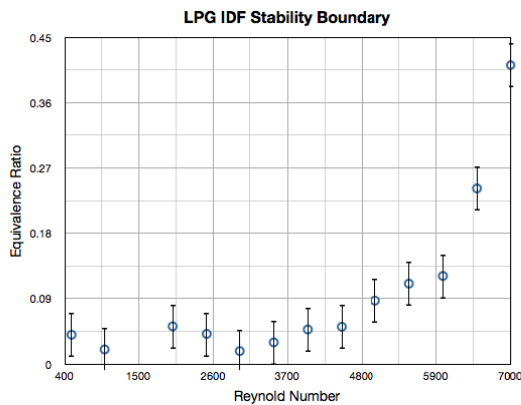

Fig. 4 LPG-IDF's Stable Boundary Regarding to Re and Equivalence Ratio

When air jet velocity was relatively low, such as that at $Re=500-2000$, stable flame could be seen even with low fuel velocity. This phenomenon may be due to when the interference of air jet on fuel jet was low, the flame was mainly affected by buoyance force, such that it appeared as blue and quiet [7]. When Re rose, large pressure caused by the velocity difference entrained fuel jets to the central air jet and formed a flame neck, which was the mixer and holder for the flame torch[19]. An entrainment zone[4] was formed at the root of flame, which was usually called the flame base. The entrainment results in better air-fuel mixing[24] and longer residence time for soot. The fuel jet velocity should be high enough to catch up entrainment force and flame speed to form stable flame. Under high Re , the central air jet also exerted shear-lifting force onto fuel jets. Higher velocity was required for the fuel jets to cover the significantly increased shear lifting force.

Similar to Fig. 3, Fig. 4 indicates that the lower limit of equivalent ratio also climbs with Re . Stable flame could be achieved under fuel lean condition when Re was in the range of 500-7000. Even when Re was as large as 7000, flame could be stable with $\Phi=0.41$. Fluctuation occurred between $Re=1000$ and $Re=2500$, which might be because of flame structure

transformation.

Stability range of hydrogen enriched LPG-IDFs was also tested. Very low percentage of hydrogen could significantly enlarge stable range of the LPG-IDFs. The result might be due to the very low density of hydrogen, which speeded up the fuel mixture release rate.

B. Flame Structure

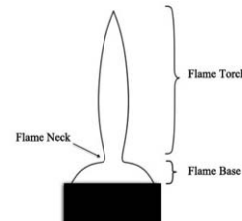

Fig. 5 IDF Flame Structure

Wu [25] classified IDF into six types according to the flame shapes. IDF flame shapes highly depended on equivalence ratio and Reynolds Number. Flames of LPG and H_2 -LPG mixture appeared in different flame types under different Re . To simplify the problem, experiments were done for flames at $\Phi=0.5, 0.7, 1, 1.2, 1.5, 1.7, 2,$ and 2.2 under $Re=1500$ and $Re=3000$, respectively. The flame were all with clear flame torch, flame neck and flame base. For $Re=1500$ the flames had thinner flame torch with narrow and sharp tip. For $Re=3000$, the flames showed wider inner cores, and shapes of flame torches were more close to an ellipse.

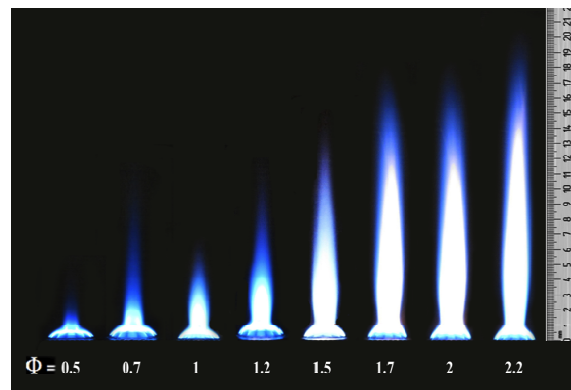

Fig. 6 LPG-IDFs, $Re=1500$

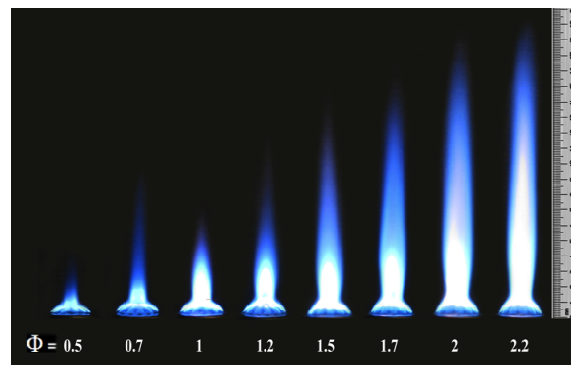

Fig. 7 LPG with 50% Hydrogen IDF, $Re=1500$

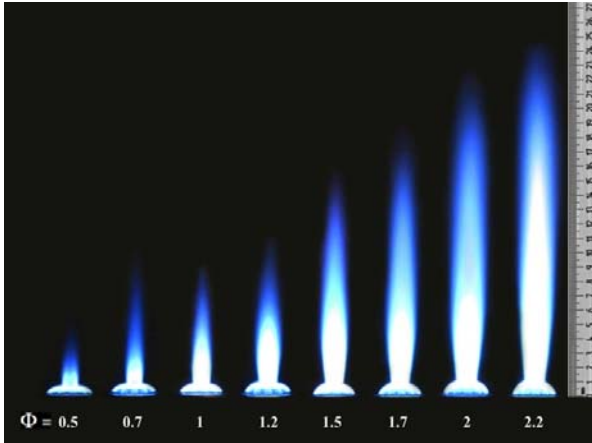

Fig. 8 LPG-IDFs, Re=3000



Fig. 9 LPG with 50% Hydrogen IDFs, Re=3000

It can be observed from **Fig. 6-Fig. 9** that the flame length was lengthened steadily with Φ when Re was fixed. No obvious changes were observed in flame base. For LPG-IDF at Re=1500, the flames were elongated from 36 mm to 202 mm as Φ was increased from 0.5 to 2.2. After augmenting Re to 3000, LPG-IDF showed the flame length changing from 46 mm to 250 mm within the same Φ range. The data for 50% hydrogen-enriched LPG-IDF were 38 mm to 174 mm and 48 mm to 237 mm, respectively under the same experimental condition. The increment of Re led to significant growth in flame length for both LPG-IDF and H₂-LPG-IDF. 50% addition of hydrogen contributed about 5%-14% reduction in flame length. Zhen, Mishra, and Kumar also found hydrogen addition to LPG fuel could shorten flame length[26]-[27]. With the increase of Φ , accelerated fuel jet could catch up with high-speed air jet to form a longer flame. The air jet entrained fuel into centerline of flame, and severely mixing of air and fuel produced the bright blue flame appearance. When the fuel supply rate was high, there was not enough time for all the fuel to be burned completely in entrainment zone, thus yellow flame formed by increased amount of soot formation could be noticed. Also the reduced difference between air/fuel velocities led to a wider flame neck under high Φ values.

C. Flame Height

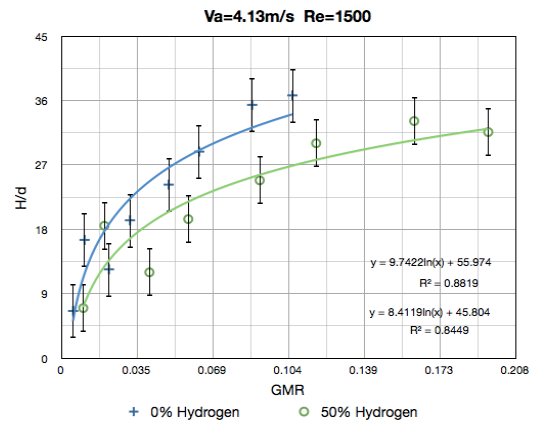

Fig. 10 Correlation between GMR and H/d, Re=1500

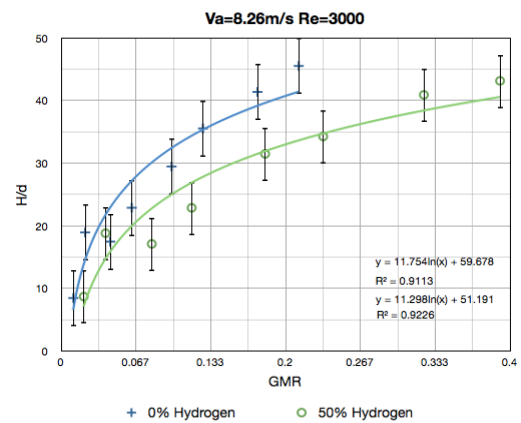

Fig. 11 Correlation between GMR and H/d, Re=3000

Detailed flame length data as presented from Fig. 6 to Fig. 9 are correlated with the concept of GMR and shown in Fig. 10 and Fig. 11. The flame length is also called luminous flame height and is defined as the distance between burner exit and the point where the flame is no longer visible to human eye[28]. Flame length can provide information about the burning condition. Mahesh found that the Global momentum ratio (GMR) could correlate well with the visible flame length of turbulent LPG-IDF[24]. In this study, flame length data at Re=1500 and Re=3000 were collected. Fig. 10 and Fig. 11 imply that the normalized flame height H/d also shows acceptable correlation with GMR for both LPG-IDF and H₂-LPG-IDF. TABLE II demonstrates that GMR values are higher for LPG-IDF than for H₂-LPG-IDF. It is because H₂-LPG fuel has higher fuel velocity for the same equivalence ratio than LPG fuel does. The graphs indicate that in fuel lean and stoichiometric conditions (the first 3 points in graph), flame lengths of LPG-IDF and H₂-LPG-IDF are very close. But for fuel rich conditions, H₂-LPG-IDFs are shorter than that of LPG-IDFs, and the difference between flame lengths is elongated with the equivalence ratio. This phenomenon is coincident in both Re=1500 and Re=3000 situations. Correlation between GMR and flame length for four conditions

are listed as below:

TABLE II
RESULT OF FLAME LENGTH CORRELATION

Condition	Correlation
Re=1500 LPG IDF	$H/d=9.74\ln(\text{GMR})+55.97, (R^2=0.8819)$
Re=1500 H ₂ -LPG IDF	$H/d=8.41\ln(\text{GMR})+59.68, (R^2=0.8449)$
Re=3000 LPG IDF	$H/d=11.75\ln(\text{GMR})+59.68, (R^2=0.9113)$
Re=3000 H ₂ -LPG IDF	$H/d=11.30\ln(\text{GMR})+51.19, (R^2=0.9226)$

Better correlations were achieved under Re=3000 than that under Re=1500. Further experiments are in need to collect enough data for flame length prediction and simulation.

V. CONCLUSION

In the present study, flame stability, flame structure and flame length of LPG-IDFs and 50% H₂-LPG-IDFs had been studied. The following results were obtained:

- 1) The LPG-IDFs were stable in a wide range as defined by Re=500-7000 even under fuel lean condition. Small percentage addition of hydrogen could give significantly enlargement on LPG-IDFs stable range.
- 2) Lengths of LPG-IDFs obtained under a fixed Reynolds number were gradually increased with equivalence ratio.
- 3) 50% hydrogen-enriched LPG-IDFs also appeared to have similar structure changes under the same range of equivalence ratios as that of the LPG-IDFs.
- 4) Lengths of both LPG-IDFs and H₂-LPG-IDFs could be correlated well with GMR at Re=1500 and Re=3000. LPG-IDFs were seen to be longer than H₂-LPG-IDFs in fuel rich situations.

ACKNOWLEDGMENT

The authors thank The Hong Kong Polytechnic University for financial support of the present study.

REFERENCES

- [1] Gupta and R. B, Hydrogen Fuel: Production, Transport, and Storage. CRC Press.
- [2] EkinsPaul, Hydrogen Energy: Economic and Social Challenges. Earthscan, 2010.
- [3] E. M. Clausing, D. W. Sensor, and N. M. Iaurendeau, "Pecllet Correlation for Stability of Inverse Diffusion Flames in Methane-Air Cross Flows," *Combustion and Flame*, pp. 1-4, Aug. 1997.
- [4] L. K. Sze, C. S. Cheung, and C. W. Leung, "Temperature Distribution and Heat Transfer Characteristics of an Inverse Diffusion Flame with Circumferentially Arranged Fuel Ports," *International Journal of Heat and Mass Transfer*, vol. 47, no. 14, pp. 3119-3129, Jul. 2004.
- [5] L. Sze, C. Cheung, and C. Leung, "Appearance, Temperature, and NOX Emission of Two Inverse Diffusion Flames with Different Port Design," *Combustion and Flame*, 2006.
- [6] T. K. Ng, C. W. Leung, and C. S. Cheung, "Experimental Investigation on the Heat Transfer of an Impinging Inverse Diffusion Flame," *International Journal of Heat and Mass Transfer*, vol. 50, no. 17, pp. 3366-3375, Aug. 2007.
- [7] L. L. Dong, C. S. Cheung, and C. W. Leung, "Heat Transfer Characteristics of an Impinging Inverse Diffusion Flame Jet - Part I: Free Flame Structure," *International Journal of Heat and Mass Transfer*, vol. 50, no. 25, pp. 5108-5123, Dec. 2007.
- [8] L. L. Dong, C. S. Cheung, and C. W. Leung, "Heat Transfer Characteristics of an Impinging Inverse Diffusion Flame Jet. Part II: Impinging Flame Structure and Impingement Heat Transfer,"

- [9] W. P. Partridge, JR, J. R. Reisel, and N. M. LAURENDEAU, "Laser-Saturated Fluorescence Measurements of Nitric Oxide in an Inverse Diffusion Flame," *Combustion and Flame*, pp. 1-9, Aug. 1998.
- [10] F. H. V. Coppens, J. De Ruyck, and A. A. Konnov, "The Effects of Composition on Burning Velocity and Nitric Oxide Formation in Laminar Premixed Flames of CH₄ + H₂ + O₂ + N₂," *Combustion and Flame*, pp. 409-417, Nov. 2007.
- [11] E. Hu, Z. Huang, J. He, C. Jin, and J. Zheng, "Experimental and Numerical Study on Laminar Burning Characteristics of Premixed Methane-Hydrogen-Air Flames," *International Journal of Hydrogen Energy*, vol. 34, no. 11, pp. 4876-4888, Jun. 2009.
- [12] C. G. Fotache, T. G. Kreutz, and C. K. Law, "Ignition of Hydrogen-Enriched Methane by Heated Air," pp. 1-12, Apr. 1997.
- [13] H. Guo, G. J. Smallwood, F. Liu, Y. Ju, and Ö. L. Gülder, "The Effect of Hydrogen Addition on Flammability Limit and NO_x Emission in Ultra-Lean Counterflow CH₄/Air Premixed Flames," *Proceedings of the Combustion Institute*, vol. 30, no. 1, pp. 303-311, Jan. 2005.
- [14] L. Guo, J. O. Lewis, and J. P. McLaughlin, "Emissions from Irish domestic fireplaces and their impact on indoor air quality when used as supplementary heating source," *Global NEST Journal*, 2008.
- [15] A. Y. Wagner, H. Livbjerg, P. G. Kristensen, and P. Glarborg, "Particle Emissions from Domestic Gas Cookers," *Combustion Science and Technology*, vol. 182, no. 10, pp. 1511-1527, Sep. 2010.
- [16] A. D'Anna, "Combustion-formed nanoparticles," presented at the Proceedings of the Combustion Institute, 2009.
- [17] H. J. Burbano, A. S. A. Amell, and J. M. G. a, "Effects of Hydrogen Addition to Methane on the Flame Structure and CO Emissions in Atmospheric Burners," *International Journal of Hydrogen Energy*, vol. 33, no. 13, pp. 3410-3415, Jul. 2008.
- [18] F. Cozzi and A. Coghe, "Behavior of hydrogen-enriched non-premixed swirled natural gas flames," *International Journal of Hydrogen Energy*, 2006.
- [19] L. L. Dong, C. S. Cheung, and C. W. Leung, "Combustion Optimization of a Port-Array Inverse Diffusion Flame Jet," *Energy*, vol. 36, no. 5, pp. 2834-2846, May 2011.
- [20] Gaydon, A. G. Alfred Gordon, Wolfhard, and H. G, *Flames: their structure, radiation and temperature*, 4(null) ed. Chapman and Hall, 1970.
- [21] S. Mahesh and D. P. Mishra, "Flame Stability and Emission Characteristics of Turbulent LPG IDF in a Backstep Burner," *Fuel*, 2008.
- [22] Andrzej Sobiesiaka and J. C. Wenzell, "Characteristics and Structure of Inverse Flames of Natural Gas," *Proceedings of the Combustion Institute*, 2005.
- [23] "Experimental studies of flame stability and emission characteristics of simple LPG jet diffusion flame 10.1016/j.fuel.2006.10.027 : Fuel | ScienceDirect.com," 2007.
- [24] S. Mahesh and D. P. Mishra, "Flame Structure of LPG-Air Inverse Diffusion Flame in a Backstep Burner," *Fuel*, vol. 89, no. 8, pp. 2145-2148, Aug. 2010.
- [25] K.-T. Wu and R. H. Essenhigh, "Mapping and Structure of Inverse Diffusion Flames of Methane," *Twentieth Symposium on Combustion*, pp. 1-9, Feb. 1984.
- [26] H. S. Zhen, C. S. Cheung, C. W. Leung, and Y. S. Choy, "Effects of Hydrogen Concentration on the Emission and Heat Transfer of a Premixed LPG-Hydrogen Flame," *International Journal of Hydrogen Energy*, pp. 1-9, Jan. 2012.
- [27] D. Mishra and P. Kumar, "Experimental Investigation of Laminar LPG-H₂ Jet Diffusion Flame with Preheated Reactants," *Fuel*, vol. 87, no. 13, pp. 3091-3095, Oct. 2008.
- [28] M. A. M. a, T. C. W. b, C. R. S. b, and Linda G Blevins b, "Flame height measurement of laminar inverse diffusion flames," *Combustion and Flame*.