

Sliding-Mode Control of Synchronous Reluctance Motor

Mostafa.A. Fellani, and Dawo.E. Abaid

Abstract—This paper presents a controller design technique for Synchronous Reluctance Motor to improve its dynamic performance with fast response and high accuracy. The sliding mode control is the most attractive and suitable method to use for this purpose, since it is simple in design and for its insensitivity to parameter variations or external disturbances. When this method implemented it yields fast dynamic response without overshoot and a zero steady-state error. The current loop control with decentralized sliding mode is presented in this paper. The mathematical model for the synchronous machine, the inverter and the controller is developed. The stability of the sliding mode controller is analyzed. Simulation of synchronous reluctance motor and the controller with PWM-inverter has been carried out, using the SIMULINK software package of MATLAB. Simulation results are presented to show the effectiveness of the approach.

Keywords—Dynamic Simulation, MATLAB, PWM-inverter, Reluctance Machine, Sliding-mode.

I. INTRODUCTION

THE Synchronous Reluctance Motor (SynRM) has a mechanically simple and robust structure. It can rotate at high speeds in high temperature environments because it has no rotor winding. It rotates at synchronous speeds, so the controller is simpler than other types of AC machines.

The most commonly used method of control for SynRM is field oriented control (FOC) [1]. The FOC represents the attempt to reproduce, for a SynRM, a dynamical behavior similar to that of the dc machine, characterized by the fact that the developed torque is proportional to the modulus of the stator current: to reach this objective, it is necessary to keep the rotor flux value constantly equal to the nominal value, so that, contemporarily, the optimal magnetic circuits exploitation guarantees the maximum power efficiency [2].

The conventional linear controllers such as PI, PID used with this structure are sensitive to plant parameter variation and load disturbance.

The performance varies with operating conditions, and it is also difficult to tune controller gain both on-line and off-line.

Another technique to control the torque of the SynRM is the Direct Torque Control (DTC). The name of the DTC is derived from the fact that, on the basis of the errors between the reference and the estimated values of the torque and flux it

is possible to directly control the inverter states in order to reduce the torque and flux errors within the prefixed band limits [3].

DTC controller is less sensible to the parameter detuning in comparison with FOC and it allows good torque control in steady state and transient operating conditions. Nevertheless DTC presents some drawbacks such as difficulty to control torque and flux at very low speed, high noise level at low speed, high current and torque ripple, and variable switching frequency behavior [2].

Torque disturbances and parameter variations, prone some important problems, which need to be modified. Such problems in drives, particularly in reluctance synchronous motor are the presence of harmonics, which usually leads to high torque ripple [4] and consequently mechanical vibration. Also, due to dispose the current components in a real coordinates, the current control sometimes results in a tracking problem [5] when a multiple phase system fed by PWM are manufactured.

Several methods have been used to reduce vibration and tracking problem, such as variable structure control strategy and adaptive control [6,7], but the sliding mode control is most convenient technique, due to its fast dynamic response, insensitivity to parameter variations and external disturbance rejection and of its simple implementation [8].

The theory of sliding mode control has been applied to control systems using brushless dc motors [9], induction motor and synchronous motor drives. However, its application to the reluctance motor still not manufactured.

This paper shows the design of the decentralized sliding mode-sign function of PWM inverter reluctance motor drive, in terms of current loops controller described in Tow-axis forms. Simulation is carried out by using SIMULINK software package of MATLAB for modeling the PWM-inverter and discrediting the control laws. A set of sliding mode control parameters is designed and given. The results show good performance in speed operation under the effect of external disturbances and provide an optimum level of torque with low ripples.

II. SYSTEM MODEL CONSTRUCTION

The proposed synchronous reluctance motor drive is as shown in Fig. 1. The system consists of main components: a motor, an inverter and controller. The motor is 3-phase synchronous reluctance with damping winding. The converter consists of a three phase voltage source inverter which powers

the stator of the motor. The inverter switches are driven by a PWM unit, and the gates are triggered by the 3-line voltage error signal of the motor, and carried by a triangular wave of the PWM source. The current and position sensors are used with a specific references for the feedback control, and the Tow-axis transformation blocks are applied. The sign function is designed for current loop controller in terms of speed error signal, while the resultant tow-axis motor voltage signal is transformed back into 3-phase line signal and finally fed-back to the PWM-inverter.

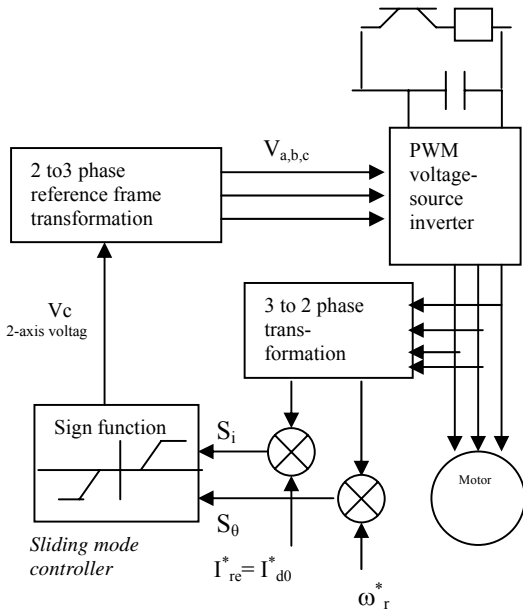

Fig. 1 Block diagram of the drive system

III. MOTOR DYNAMIC D-Q MODEL

The well known d-q model of AC machines is widely used for simulation purposes. Based on the assumption that the stator windings are sinusoidally distributed the d-q model is a powerful tool for dynamic simulation of most AC machines including the synchronous reluctance motor. The equations which describe the behavior of the synchronous reluctance motor in d-q reference frame can be written as:

$$V_d = R_s I_d + L_d \frac{dI_d}{dt} - \omega_r L_q I_q \quad (1)$$

$$V_q = R_s I_q + L_q \frac{dI_q}{dt} + \omega_r L_d I_d \quad (2)$$

Where L_d and L_q are the direct and quadrature axis winding self inductance (H), R is the stator winding resistance (Ω) and ω_r is the rotor angular speed in (rad/sec) and it is equal to θ^* .

The electromagnetic torque equation is:

$$T_e = \frac{3}{2} p(L_d - L_q) i_d i_q \quad (3)$$

The torque equation in Laplace domain is

$$T = \frac{3}{2} p(L_d - L_q) i_d i_q - (B + JS)\theta^* \quad (4)$$

Where, B and J are the damping fraction and the motor moment of inertia respectively and p is the number of pole pairs and $\theta^* = \omega_r$.

IV. PROPOSED CONTROLLER DESIGN

A. Current and Speed References

The torque and speed control are executed in the d-q reference frame. A possible strategy to control the speed by sliding mode consists of controlling the direct and quadrature currents, so that the motor torque depends on the multiplication of both current components. Thus, for the current, the reference is specified in d-axis as $i_{ref} = i_{d0}$, and for the speed, the reference is specified as $\omega_{ref} = \theta^* = 0$. While the current in q-axis is now depends on both direct current and speed, through the torque equation.

B. Sliding Conditions

Consider S denotes the sliding surface and v_c is the resultant Tow-axis control voltage vector. The sliding mode control can be achieved if there exists a control law, such that the condition $SS^* < 0$ is satisfied [14]. The solution of v_c is therefore:

$$V_c = V_{dq} - U_{dq} \quad (5)$$

Where vdq is the Tow-axis motor voltage components given in (2) and udq is the designed sliding voltage components. Since the sliding mode is obtained by changing the structure of the controller on either side of the sliding surface "S" [14] such as the position error trajectory is forced to follow it's till origin of the phase plane. Thus, the design of vdq is obtained by an exact feedback linearization of S. While u_{dq} is designed in such a way to fulfill the condition of the state trajectories to be attracted toward the surface $S=0$. The control law is therefore established to follow on the given sliding surfaces below:

Subject to: $S_i = -i_d = 0$ and $S_i S_i^* < 0$

The current sliding surface is: $S_i = -i_d$

Subject to: $S_\theta = -c\theta - \theta^* = 0$ and $S_\theta S_\theta^* < 0$

The speed sliding surface is:

$$S_\theta = -c(\theta^* - \theta) + (\theta_0^* - \theta) = 0 \quad (6)$$

These imply:

$$i_d^* = 0, \quad \theta_0^* = 0 \quad \text{and} \quad \dot{\theta} = -c\theta \quad (7)$$

C. The Sign Function

The sign function is a discrete odd function of unity magnitude and specified time stepping. It is a function of the sliding surface S , such that for both current surface S_i and speed surface S_θ , the function takes the form of Fig. 2.

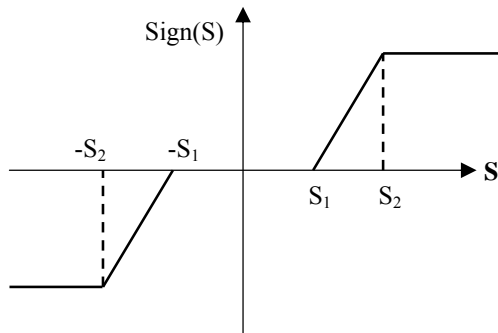

Fig. 2 The sign function

D. The Controller

The sliding voltage components u_{dq} are designed in the form: $u_d = k_d \text{Sign}(S_i)$ and $u_q = k_q \text{Sign}(S_\theta)$.

Taking into account the existence condition of the sliding control and the stability condition of the system $SS^* < 0$, the two components of the resultant Tow-axis voltage vector v_{dq} are calculated as follows:

From equation (2) and at no load ($T=0$) we get:

$$i_q = \frac{B\theta^* + J\dot{\theta}^*}{i_d(L_d - L_q)} \quad (8)$$

But from (7) $\dot{\theta} = -c\theta$ hence:

$$i_q = \frac{(B\theta - Jc)\theta^*}{(L_d - L_q)i_d} \quad (9)$$

Therefore

$$v_{dc} = v_d + u_d = R_s i_d - L_q i_q \dot{\theta} + k_d \text{sign}(S_i) \quad (10)$$

$$v_{qc} = v_q + u_q = R_s i_q + (L_d i_d + \frac{B - Jc}{(L_d - L_q)} S) \dot{\theta} + k_q \text{sign}(S_\theta) \quad (11)$$

Where, c , k_d and k_q are constant parameters, they are tuned to obtain an acceptable value of voltage.

The resultant Tow-axis voltage vector V_c is then transformed back into 3-phase components.

The 3-line voltage are then injected to the PWM-inverter and carried by a triangular wave of frequency (3 kHz) and amplitude 100, modulated with voltage control. The dc link voltage is fixed at 70 V.

V. SIMULATION RESULTS

Using the methodology described in the previous section, simulation is carried out by constructing the control model in the SIMULINK/MATLAB software. Figs. 3, 4 show the step response of the system to a speed reference of 100 rad/sec and current reference of 0.75 A.

The system parameters are:

The stator resistance $R_s = 15\Omega$, d-axis inductance $L_d = 0.2$ H, q-axis inductance $L_q = 0.05$ H, the moment of inertia $J = 0.03$ kg.m and the viscous friction $B = 0.001$ kg.m²/sec.

In Figs. 3, the sliding mode control parameters are as shown in Table I.

TABLE I
SLIDING MODE CONTROL PARAMETERS

C	1000
k_d	100
k_q	20
S_{i1}	1
S_{i2}	10
$S_{\theta 1}$	2
$S_{\theta 2}$	50

In Figs. 4, the sliding mode control parameters are as shown in Table II.

TABLE II
SLIDING MODE CONTROL PARAMETERS

C	10
k_d	10
k_q	100
S_{i1}	0.2
S_{i2}	1
$S_{\theta 1}$	0.1
$S_{\theta 2}$	2

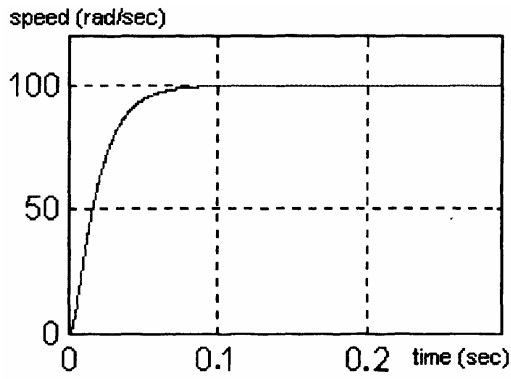

Fig. 3a Speed response

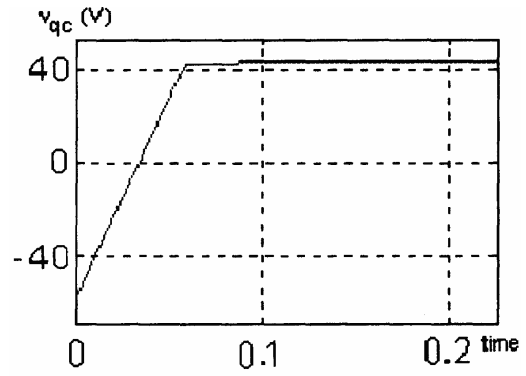

Fig. 3e q-axis controlled voltage

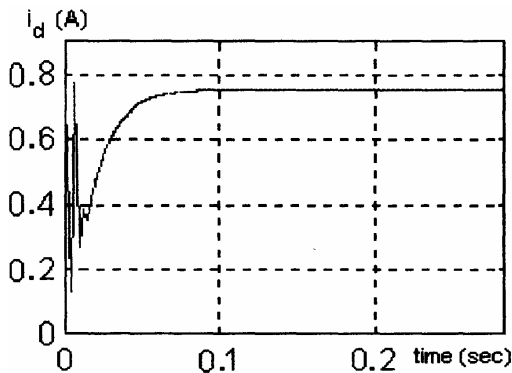

Fig. 3b Response of direct current

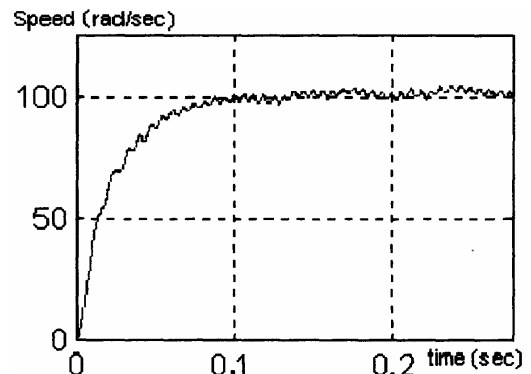

Fig. 4a Speed response

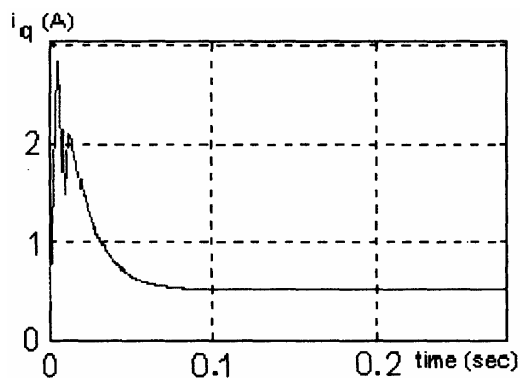

Fig. 3c Response of quadrature current

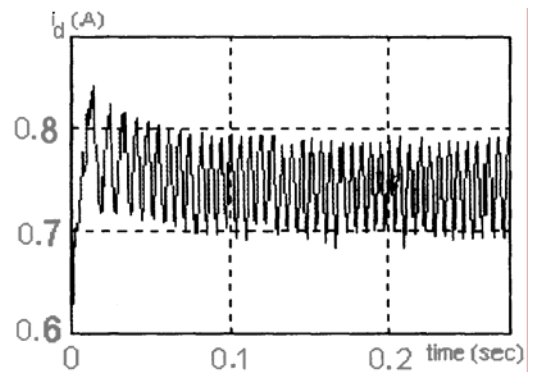

Fig. 4b Response of direct current

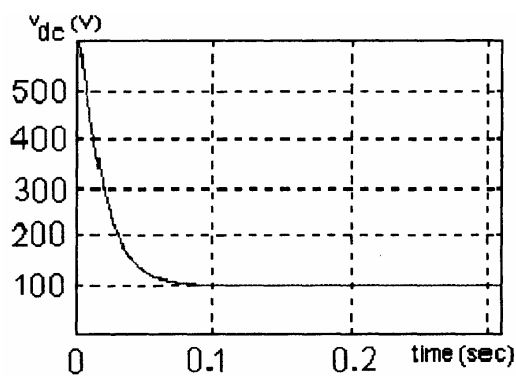

Fig. 3d d-axis controlled voltage

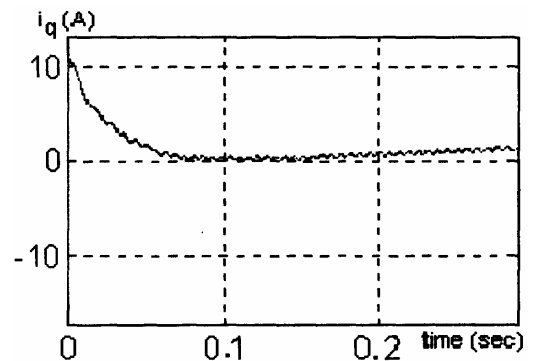

Fig. 4c Response of quadrature current

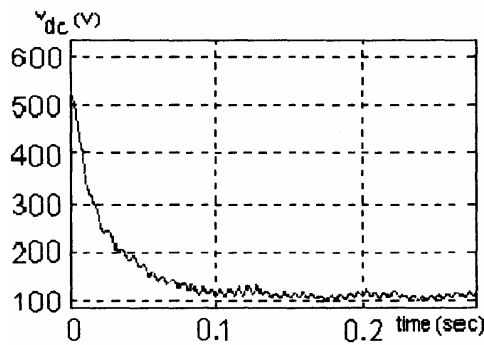

Fig. 4d d-axis controlled voltage

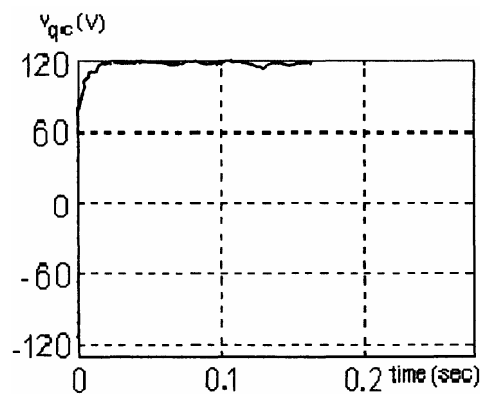

Fig. 4e q-axis controlled voltage

It is clear that there are different between the tow sets of figures above, according to the selected values of the sliding mode parameters. For the machine used in this test, the suitable parameters are given for Figs. 3, and those establish a good performance of the overall control system. These results show no steady-state error and no chattering or ripples. While parameters like in Figs. 4, illustrate little swaying in the response of most of variables. This might be because the system is operating in the instability boundary. It has been tested, for the parameters given for Figs.4 that the motor is working at the critical stable point, which can be recognized by the speed curve.

The figures, however, illustrate a good efficiency of the control strategy, and chattering of the control and the corresponding ripple are considerably reduced, and are absence in the results of Figs. 3.

VI. CONCLUSION

This paper highlights the application of a sliding mode controller to robust speed control of Synchronous reluctance motor drive.

The design of the sliding mode controller is described and both direct current and speed control laws are investigated. Reducing of ripples that caused by the high frequency of the voltage source inverter can be obtained by using the sign function, which is designed to match the requirements of the reluctance motor operation and implemented for this type of control.

Chattering and torque ripple are reduced by the control strategy and consequently the efficiency is improved, since the efficiency is usually handicapped in the electric drives by chattering, as is known. The system is ready made on the MATLAB/SIMULINK, and the simulation is given.

REFERENCES

- [1] p. Pillay, r. Krishnan, "Modeling, simulation, and analysis of permanent-magnet motor drives. i. The permanent-magnet synchronous motor drive", IEEE Trans. Industry Applications, Vol 25, n°2 Mar/Apr 1989 pp: 265-273.
- [2] m. Rodic, k. Jezernik, "Speed Senseless Sliding Mode Torque Control of Induction Motor", IEEE Trans on. Industrial Electronics, February 2002.
- [3] m. f. Rahman, I. Zong and k. w. Lim, " a Direct Torque Controlled Interior Permanent Magnet Synchronous Motor Drive Incorporating Field Weakening ", IEEE Trans on. Industry Applications, Vol. 27, N° 5, Sep/Oct 1991, pp. 986-996.
- [4] Carlson, R., Cros, J. & Lajoic, M., 'The analytical determination of the characteristics of permanent magnet brushless dc drives', Proc. European Conf. On Power Electronics 1991, Firenze Vol.3, pp.468-471.
- [5] Kazmierowski, M.P. & Dzieciakowski, M.A., 'Review of current regulation methods for VSPWM inverters', Proc. Int. Symposium on Industrial Electronics 1993, Budapest, pp.448-456.
- [6] Marongiu, I. & Serri, A., 'Model reference control of PM synchronous motors', Proc. Electric drive symposium 1990, Capri, pp.171-176.
- [7] Sabanovic, A. & Olinishi, N.K., 'Sliding modes in power converters and motion control systems', Int. journal of control Vol.57, No.5, 1993, pp.1237-1259.
- [8] Ramirez, H.S., 'Sliding mode control of slow manifolds of dc-dc power converters', Int. journal of control, No.47, 1988, pp.235-242.
- [9] Harashima, F., Hashimoto, H & Kondo, S., 'MOSFET converter-fed position servo system with sliding mode control', IEEE Trans. On Industrial Electronics, Vol. 1E-32, No.3, 1985, pp.238-244
- [10] Sabanovic, A. & Izosimov, D.B., 'Application of sliding modes to induction motor', IEEE Trans. On Industrial Electronics, Vol.IA-17, No.1, 1981, pp.4149.
- [11] Benklitoris, M.F., Dedecius, D., Siala, S. & Glumineau, A., 'Digital simulation of sliding mode control of brushless servo-motor', Proc. ICEM, France 1994, Vol.2, pp.523-528.
- [12] Mostafa, M.A & Nagrial, M., 'Dynamic control of synchronous reluctance drive', Proc. AUPEC conference, Sydney, 1997, Vol.1, pp.121-124.
- [13] Weh, H. and Schroeder, U., 'Static inverter concepts for multiphase machine with square wave current field distributions', Proc. UPEAC cotif, Brussels, 1985, pp.1147-1152.
- [14] Utkin, V., 'Sliding modes and their applications in variable structure systems', Moscow: Mir, 1981.