

# Realization of Electronically Tunable Current-Mode Multiphase Sinusoidal Oscillators using CFTAs

Prungsak Uttaphut

**Abstract**—An implementation of current-mode multiphase sinusoidal oscillators is presented. Using CFTA-based lossy integrators, odd and odd/even phase systems can be realized with following advantages. The condition of oscillation and frequency of oscillation can be orthogonally tuned. The high output impedances facilitate easy driving an external load without additional current buffers. The proposed MSOs provide odd or even phase signals that are equally spaced in phase and equal amplitude. The circuit requires one CFTA, one resistor and one grounded capacitor per phase without additional current amplifier. The results of PSPICE simulations using CMOS CFTA are included to verify theory.

**Keywords**—multiphase sinusoidal oscillator; current-mode; CFTA; lossy integrator

## I. INTRODUCTION

IT is well known that multiphase sinusoidal oscillator (MSO) is important blocks for various applications. For example, in telecommunications it is used for phase modulators, quadrature mixers [1], and single-sideband generators [2]. In measurement system, MSO is employed for vector generator or selective voltmeters [3]. It can also be utilized in power electronics systems [4]. Recently, current-mode circuits have been receiving considerable attention of due to their potential advantages such as inherently wide bandwidth, lower slew-rate, greater linearity, wider dynamic range, simple circuitry and low power consumption [5]. The current follower transconductance amplifier (CFTA) is a recently reported active component. It seem to be a versatile component in the realisation of a class of analog signal processing circuits, especially analog frequency filters [6-7]. It is really current-mode element whose input and output signals are currents. In addition, it can also adjust the output current gain.

A number of current-mode MSOs using different active building blocks are available in the literature. These include realizations using current follower (CF) [8], CCCII [9]-[10], most recently by CDTA [11]-[13] and CCCCTA [14]-[15]. The CF-based MSO in [8] requires two current followers, one floating resistor, and one floating capacitor for each phase and thus the circuit is not suitable for monolithic integration. Moreover, it cannot be electronically controlled. The CCCII-based MSOs [9]-[10] enjoy high-output impedances and electronic tunability.

P. Uttaphut is with the Department of Electrical Technology, Faculty of Industrial Technology, Suan Sunandha Rajabhat University, Bangkok, 10300, Thailand (e-mail: prongsaku@hotmail.com).

However, the first one requires a large number of external capacitors. In addition, the oscillation condition can be provided by tuning the capacitance ratio of external capacitors, which is not easy to implement.

The second reported circuit requires additional current amplifiers, which makes the circuit more complicated and increases its power consumption. CDTA-based current-mode MSOs in [11] is based on lossy integrators, whereas the circuits in [12] and [13] contain CDTA-based allpass sections. They exhibit good performance in terms of electronic tunability, high-output impedances, and independent control of the oscillation frequency and the oscillation condition. However, MSOs in [11] and [12] require an additional current amplifier, which is implemented by two CDTAs.

Moreover, the output currents of the MSO, utilizing the CDTA-based lossy integrators, are of different amplitudes. The MSO employing CDTA-based allpass sections [12] requires two CDTAs in each allpass section, and the circuitry becomes more extensive. While MSO using CDTA-based allpass sections [13] requires floating capacitor.

Consequently, it occupies a larger chip area for VLSI design. In addition, its power consumption is also increased. MSOs using CCCCTAs have been proposed in [14] and [15]. They provide following advantages: electronic tunability, high-output impedances, independent control of the oscillation frequency and the oscillation condition, no use of external current amplifier. However, MSOs in [14] and [15] require external resistor per phase. The proposed MSOs are compared with previously published MSOs of [9-15] and the results are shown in Table 1. The purpose of this study is to introduce a new current-mode multiphase sinusoidal oscillator.

The features of the proposed circuit are the following: (I) Use of grounded capacitors and identical circuit configuration for each section in the MSO topology which are suitable for integration. (II) The electronic tunability of oscillation condition and oscillation frequency. (III) High-impedance current outputs. (IV) The possibility of generating multi-phase signals for both an even and odd number of equally-spaced in phases. (V) Independent tuning of the oscillation frequency and the oscillation condition. (VI) Equality of amplitudes of each phase due to utilizing identical sections. (VII) Requirement for only one CFTA as the active element for each phase without any additional current amplifiers.

II. THEORY AND PRINCIPLE

A. Basic Concept of CFTA

Since the proposed circuit is based on CFTA, a brief review of CFTA is given in this section. The schematic symbol and the ideal behavioural model of the CFTA are shown in Fig. 1(a) and (b). It has one low-impedance current input  $f$  port. The current  $i_f$  flows from port  $z$ . The voltage  $v_z$  on  $z$  terminal is transferred into current using transconductance  $g_m$ , which flows into output terminal  $x$ . The  $g_m$  is tuned by  $I_B$ . In general, CFTA can contain an arbitrary number of  $x$  terminals, providing currents  $I_x$  of both directions. The characteristics of the ideal CFTA are represented by the following hybrid matrix:

$$\begin{bmatrix} V_f \\ I_z \\ I_x \end{bmatrix} = \begin{bmatrix} 0 & 0 & 0 \\ 1 & 0 & 0 \\ 0 & 0 & \pm g_m \end{bmatrix} \begin{bmatrix} I_f \\ V_x \\ V_z \end{bmatrix} \quad (1)$$

For CMOS CFTA, the  $g_m$  is written as

$$g_m = \sqrt{kI_B} \quad (2)$$

where  $k = \mu_o C_{ox} (W/L)$  is the thermal voltage. Here  $I_B$  is the input bias current. Internal construction of CFTA is shown in Fig. 2.

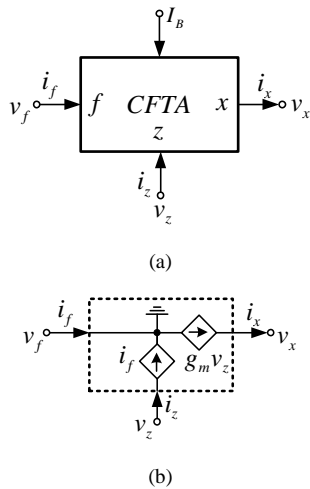

Fig. 1 CFTA (a) Symbol (b) Equivalent circuit

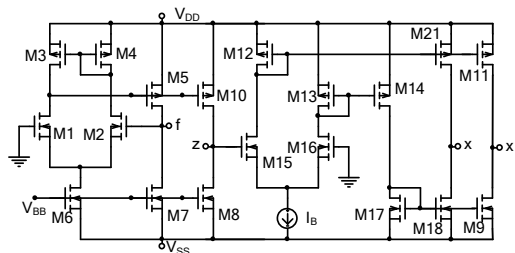

Fig. 2 Schematic of the CMOS CFTA

B. Implementation of  $n$ -cascaded lossy integrator-based MSO

The generalized structure of MSO by cascading the  $n$  identical stages ( $n \geq 3$ ) is shown in Fig. 2 which containing the lossy integrator (first order low pass filter) for each phase. The output of  $n$ th stage is fed back to the input of the first stage, and the signal of the last section is non-inverted for odd phase system and inverted for odd or even phase system. It is found in Fig. 2 that the system can provide one phase per one lossy integrator without any additional external amplifier. The system loop gain for odd phase system can be written as follows [16]:

$$L(s) = \left( \frac{-k}{sa+1} \right)^n \quad (3)$$

where the symbol  $k$  is the current gain and  $a$  denotes the natural frequency of each integrator section. At the oscillation frequency  $\omega_{osc} = 2\pi f_{osc}$ , the Barkhausen's condition can be written as

$$L(s) = \left( \frac{-k}{sa+1} \right)^n \quad (4)$$

or

$$(j\omega_{osc} a + 1)^2 + (-1)^{n+1} (k)^n = 0 \quad (5)$$

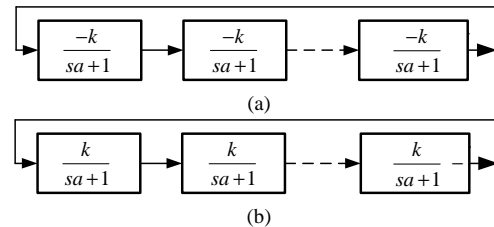

Fig. 3 MSO block diagram for (a) odd phase (b) odd/even phase

Considering in Eq. (5) for  $n = 3, 5, 7, \dots$ , the frequency of oscillation (FO) and condition of oscillation (CO) are expressed as [16]

$$\omega_{osc} = \frac{1}{a} \tan \frac{\pi}{n} \quad (6)$$

or

$$k \geq \sec \frac{\pi}{n} \quad (7)$$

Considering Eqs. (6) and (7), the oscillation condition can be controlled independently of the oscillation frequency by the gain  $k$ , while the oscillation frequency can be changed by the natural frequency  $a$ .

C. Proposed *n*-cascaded lossy integrator-based MSOs

As mentioned in the above section, the proposed MSO is based on identical lossy integrator sections. A prospective CFTA-based implementation is shown in Fig. 4. It is seen that proposed lossy integrator circuit consists of 1 CFTA, 1 resistor and 1 grounded capacitor. The current transfer function can be written as follows:

$$\frac{I_o(s)}{I_{in}(s)} = \pm \frac{g_m R}{sCR + 1} \tag{8}$$

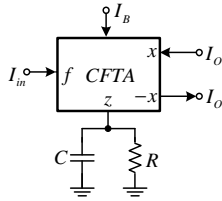

Fig. 4 CFTA-based current-mode lossy integrator

According to Eq. (6) and (7), the oscillation condition and oscillation frequency for odd phase system are as follows:

$$\omega_{osc} = \frac{1}{CR} \tan \frac{\pi}{n} \tag{9}$$

or

$$g_m R \geq \sec \frac{\pi}{n} \tag{10}$$

From Eq. (9) and (10), it can be seen that the CO can be adjusted electronically/independently from the FO by varying  $g_m$  (or  $I_B$ ) while the oscillation frequency can be adjusted by R. The resulting current-mode MSOs are shown in Fig. 5(a) and (b) for odd and odd/even phase system, respectively.

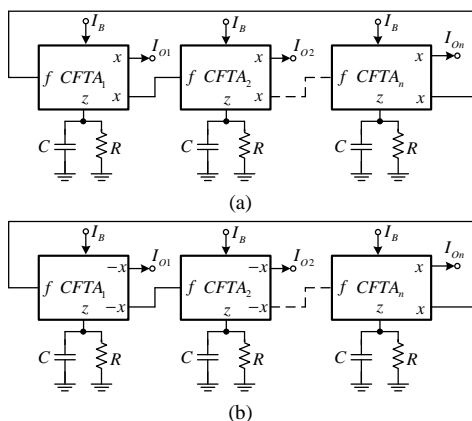

Fig. 5 Proposed current-mode MSO (a) odd phase (b) odd/even phase

III. RESULTS OF COMPUTER SIMULATION

The working of the proposed circuit has been verified using PSpice simulation program. The PMOS and NMOS transistors have been simulated by respectively using the parameters of a 0.25 $\mu$ m TSMC CMOS technology [18].

The aspect ratios of PMOS and NMOS transistor are listed in Table I. Fig. 2 depicts schematic description of the CFTA used in the simulations. The circuit was biased with  $\pm 1.5V$  supply voltages.

Firstly, an odd three-phase sinusoidal oscillator ( $n=3$ ) based on the structure in Fig. 3(a) has been designed on the basis of Fig. 5(a). The component values are as follows:  $I_B=225\mu A$ ,  $R=1.2k\Omega$ ,  $C=0.1nF$ . The simulated output waveforms,  $I_{O1}$ ,  $I_{O2}$  and  $I_{O3}$  are shown in Fig. 6. The frequency of oscillation achieved was 2.435MHz. The frequency spectrum of output currents are shown in Fig. 7. The total harmonic distortion is about 0.354%.

TABLE I  
 DIMENSIONS OF THE TRANSISTORS

Transistor	W ( $\mu$ m)	L ( $\mu$ m)
M1-M9	5	0.5
M10-M11	16	0.25
M12-M13	8	0.25
M14-M16, M18-21	15	0.5
M17	15.1	0.5

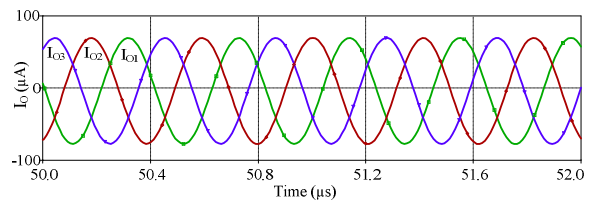

Fig. 6 Current outputs of the proposed MSO ( $n=3$ )

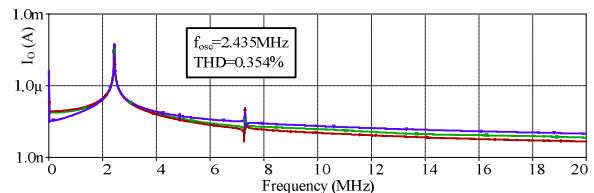

Fig. 7 Spectrum of signal in Fig. 6

Secondly, an even four-phase sinusoidal oscillator ( $n=4$ ) based on the structure in Fig. 3(b) has been designed on the basis of Fig. 5(b).  $I_B=88\mu A$ , another component values are same to previous investigation.

The simulated output waveforms,  $I_{O1}$ ,  $I_{O2}$ ,  $I_{O3}$  and  $I_{O4}$  are shown in Fig. 8. The frequency of oscillation achieved was 1.413MHz. The frequency spectrum of output currents are shown in Fig. 9. The total harmonic distortion is about 0.639%.

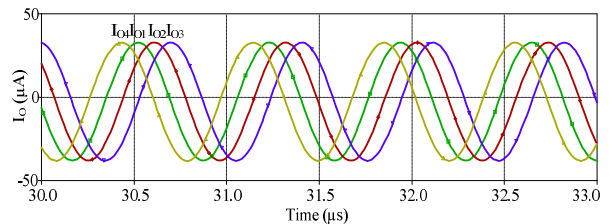

Fig. 8 Current outputs of the proposed MSO ( $n=4$ )

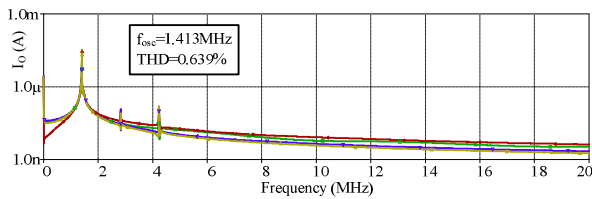

Fig. 9 Spectrum of signal in Fig. 8

#### IV. CONCLUSIONS

A new current-mode multiphase sinusoidal oscillators using CFTA-based lossy integrators with grounded capacitors have been presented. The features of the proposed circuit are that: oscillation frequency and oscillation condition can be independently tuned; the proposed oscillator consists of merely 1 CFTA, 1 resistor and 1 grounded capacitor for each phase and no additional current amplifier and availability of explicit-current outputs from high-output impedance terminals. PSPICE simulation results agree well with the theoretical anticipation.

#### REFERENCES

- [1] J. Dunlop, D. G. Smith, Telecommunications Engineering, 3rd ed. CRC Press, 1994.
- [2] [W. Tomasi, Electronic Communications System, New Jersey: Prentice-Hall Inc., 1998
- [3] Anritsu Emea Limited: MG3700A vector signal generator datasheet, Available at: [http://www.eu.anritsu.com/files/MEG3700A\\_EI17301.pdf](http://www.eu.anritsu.com/files/MEG3700A_EI17301.pdf).
- [4] G. Eirea, S. R. "Sanders, Phase current unbalance estimation in multiphase buck converters," IEEE Transactions on Power Electronics, vol. 23, pp. 137-143, 2008.
- [5] C. Toumazou, F. J. Lidgey, D. G. Haigh, Analogue IC design: the current-mode approach. Peter Peregrinus: London, 1990.
- [6] D. Biolek, R. Senani, V. Biolkova, Z. Kolka "Active elements for analog signal processing: classification, review, and new proposals," Radioengineering, vol. 17, no. 4, pp. 15-32, 2008.
- [7] N. Herencsar, J. Koton, K. Vrba and J. Misurec, "A novel current-mode SIMO type universal filter using CFTAs," Contemporary Engineering, Sciences, vol.2, no.2, pp.59-66, 2009.
- [8] M. T. Abuelma'Atti "Current-mode multiphase oscillator using current followers," Microelectronics Journal, vol. 25, pp. 457-461, 1994.
- [9] M. T. Abuelma'atti, M. A. Al-Qahtani, "A new current-controlled multiphase sinusoidal oscillator using translinear current conveyor," IEEE Transactions on. Circuits and Systems, vol. 45, pp. 881-885, 1998.
- [10] C. Loescharataradee, W. Kiranon, W. Sangpisit, W. Yadum, "Multiphase sinusoidal oscillators using translinear current conveyors and only grounded passive components," Proceeding of Southeastern Symposium on System Theory, pp. 59-63, 2004.
- [11] W. Tangsrirat, W. Tanjaroen "Current-mode multiphase sinusoidal oscillator using current differencing transconductance amplifiers," Circuits, Systems and Signal Processing, vol. 27, pp. 81-93, 2008.
- [12] W. Tangsrirat, W. Tanjaroen, T. Pukkalanun,. "Current-mode multiphase sinusoidal oscillator using CDTA-based allpass sections," International Journal of Electronics and Communications (AEU), vol. 63, pp. 616-622, 2009.
- [13] W. Jaikla, M. Siripruchyanun, D. Biolek D., V. Biolkova, "High-output-impedance current-mode multiphase sinusoidal oscillator employing current differencing transconductance amplifier-based allpass filters," International Journal of Electronics, vol. 97, pp. 811-826, 2010.
- [14] M. Kumngern "Electronically tunable current-mode multiphase oscillator using current-controlled CCTAs," 2010 IEEE International Conference of Electron Devices and Solid-State Circuits (EDSSC), 2010.

- [15] P. Uttaphut, W. Mekhum, W. Jaikla, "Current-mode multiphase sinusoidal oscillator using CCCCTAs and grounded elements," 9th International NEWCAS conference, pp. 345-349, 2011.
- [16] D. S. Wu, S. I. Liu, Y. S. Hwang, Y. P. Wu "Multiphase sinusoidal oscillator using the CFOA pole," IET Circuits, Devices & Systems, vol. 142, pp. 37-40, 1995.
- [17] C. Psychalinos, G. Souliotis "A log-domain multiphase sinusoidal oscillator," International Journal of Electronics and Communications (AEU), vol. 62, pp. 622-626, 2008.
- [18] P. Prommee, K. Angkeaw, M. Somdunyanok, and K. Dejhan, "CMOS-based near zero-offset multiple inputs max-min circuits and its applications," *Analog Integr. Circuits Signal Process.* Vol. 61, pp. 93-105, 2009.