

REPORT:

A3.3.5: Guidelines for the implementation of standardised methods of microfluidic components focusing on port connection from microscale fluidic channels to the macroscale world and associated changes in flow and pressure

This report was written as part of activity 3.3.5 from the EMPIR Establishing Metrology Standards in Microfluidic Devices (MFMET) project. The three-year European project commenced on 1st June 2021 and focused on providing a generic methodology of accurate measurement of a particular quantity in a microfluidic device by utilising standardised methods and reference documents, e.g. VIM & GUM. For more details about this project, please visit www.mfmet.eu

This report was written by:

| | | |
|-------------------------|-------------|--|
| Christina Pecnik | IMTAG | cpecnik@imtag.ch christina.pecnik.micro@outlook.com |
| Winfried Arens | IMATG | warens@imtag.ch |
| Henne van Heeren | enablingMNT | henne@enablingmnt.com |
| Elsa Batista | IPQ | ebatista@ipq.pt |
| Huabing Yin | UofG | Huabing.Yin@glasgow.ac.uk |

EMPIR



The EMPIR initiative is co-funded by the European Union's Horizon 2020 research and innovation programme and the EMPIR Participating States

Contents

| | |
|--|----|
| 1. Scope..... | 4 |
| 2. Executive summary | 5 |
| 3. Requirements for connectors for microfluidic operations | 6 |
| 4. Connection types | 7 |
| 4.1. Connectors for microfluidic chips made of glass | 8 |
| 4.1.1. Clamped connector fixed on top or bottom of the chip..... | 8 |
| 4.1.2. Flared connector to the side of the chip..... | 9 |
| 4.1.3. Glued connectors | 10 |
| 4.2. Connectors for microfluidic chips made of polymer | 10 |
| 4.2.1. Luer connectors | 10 |
| 4.2.2. Hose and barbed connectors | 11 |
| 4.2.3. Glued connectors | 11 |
| 4.3. Assembly of microfluidic connectors to standalone components..... | 12 |
| 5. How to test connectors?..... | 13 |
| 5. Selection of types, geometries and dimensions | 13 |
| 5.1. Towards a standard microfluidic connector | 14 |
| 6. Compatibility tests with connections and components | 15 |
| 6.1. Glass chips..... | 16 |
| 6.2. Molded plastic chips | 17 |
| 6.3. Documented example..... | 18 |
| 6.3.1. PDMS chip | 18 |
| 6.3.2. Topas chip (A)..... | 20 |
| 6.3.3. Topas chip (C)..... | 22 |
| 6.3.4. Dimensional measurements | 23 |
| 6.3.5. Results..... | 24 |
| 6.3.6. Discussion and conclusions..... | 27 |
| 7. Established solutions in commercial systems..... | 28 |

| | |
|---|----|
| References | 31 |
| 8. Appendix | 32 |
| 8.1. Flow measurement results for the 3 chip assemblies using the gravimetric method..... | 32 |
| 8.2. Flow measurement results for the 3 chip assemblies using the front rack method | 33 |

1. Scope

The objective of this document is to list the guidelines for the implementation of standardized methods of microfluidic components. These guidelines will primarily concentrate on creating effective port connections between the macroscale world and the microscale fluidic channels, while also addressing crucial issues connected to alterations in flow dynamics and pressure. This report is based on input from A3.3.1 - A3.3.4.

| Activity number | Activity description | Partners (lead in bold) |
|------------------------|---|--|
| A3.3.5 M28 | <p>Using input from A3.3.1-A3.3.4, IMTAG with support from INESC MN, TUBITAK, LNE, CEA, CETIAT and EnablingMNT will produce guidelines for the implementation of standardised methods of microfluidic components focusing on port connection from microscale fluidic channels to the macroscale world and associated changes in flow and pressure. The guidelines will be submitted to standardisation groups such as ISO/TC48/WG3 and WG5, ISO/TC229, CEN/TC332/WG7.</p> <p>Once agreed by the consortium, the coordinator on behalf of IMTAG, INESC MN, TUBITAK, LNE, CEA, CETIAT and EnablingMNT will submit the guidelines to EURAMET as D6: "Guidelines for the implementation of standardised methods of microfluidic components focusing on port connection from microscale fluidic channels to the macroscale world and associated changes in flow and pressure".</p> | IMTAG, INESC MN, TUBITAK, EnablingMNT, CEA, CETIAT, LNE |

2. Executive summary

The microfluidics world is diverse in application and technology, but what many companies have in common is that they need to connect microfluidic components and devices. Large companies can afford to make all parts in house and design and build their own connectors. Small companies, however, are forced to use connector systems that are based on connectors for other application and therefore suboptimal. The microfluidic community is therefore faced with the problem of combining microfluidic parts with different connectors that are not reliable or have other problems, like complicating the step from experimental set up to industrial manufacturing. This has been the outcome of several surveys held among microfluidic users and suppliers. To overcome this problem, we have brought together a group of companies that design and supply components and devices for the microfluidic market, with the objective of defining a connector system that offers flexibility in the research and a seamless step toward industrialization. Preferably one would like to use the same components in the commercial instrument as were used in the experimental setup. The goal of this group is to make it easier for customers to select microfluidic flow control components and devices, install and use them. The system should offer the flexibility of a tube-based system and using the same components in the final instrument. The market segments identified for this connection system are research analytical instrumentation bioreactors. They have in common that they generally operate around room temperature, low pressure and flows between 1 and 100 $\mu\text{l}/\text{min}$, with water-based fluids containing biological materials. Connectors for such applications should have low internal volume, low flow resistivity, limiting risk of biofilm formation and use biocompatible materials as wetted materials. Furthermore, the materials should also be affordable, and the supply chain sufficiently covered. The developed system should be reusable, cleanable, preferable sterilizable and leak tight.

These specifications are to be translated into tests and protocols that ensure compatibility. The technical specifications of the connectors that must be met to ensure compatibility will become freely available. A roadmap towards other applications is to be created, which should cover topics like lower and higher flow rates, gases, higher temperatures and/or pressures, smaller footprints (i.e. suitable for smaller components), multiple ports and further integration. It has been especially stated that the standard should also cover the integration of microfluidic chips and will therefore adhere to ISO 22916:2022 Microfluidic devices — Interoperability requirements for dimensions, connections and initial device classification.

The group decided that the concept will be based on a bottom down clamping of components on adapters connected to each other by 1/16" (≈ 1.6 mm outer diameter) tubes or a manifold that contains buried channels to connect the components to each other.

In the coming months we will together with the companies involved in the discussion:

- Create exact specifications of the sensor - adapter interface

- Agree on the tests to check compatibility with the requirements
- Create and test first samples
- Agree on a roadmap for future generations, covering applications not yet covered
- Disseminate the ideas

This document describes in detail microfluidic connectors currently use in the microfluidic community and describes tests to check if the developed connector system adheres to the requirements.

3. Requirements for connectors for microfluidic operations

In several fields, including biomedical research and chemical analysis, microfluidic devices make it possible to precisely manipulate and regulate small fluidic volumes and flow. However, it is essential to comprehend and take care of the key criteria that control the appearance and operation of microfluidic connections. Microfluidic connectors are a crucial part to link the microworld to the macroworld, and to the detecting part of the operation. To successfully integrate them into microfluidic systems, the following requirements include the characteristics of connectors and interconnects that affect their performance, reliability and compatibility:

- Easy handling of connection(s)
- Possibility to assemble multiple connections in one step and automatically (“plug and play”)
- Reversibility (“plug and un-plug”)
- Low cost
- Small “footprint”/area
- No leakage (low loss of fluid and limited bubble formation upon entrance)
- Smooth fluidic transitions (small effect on fluidic flow)
- Limited change of cross-section (influence on degassing due to sudden pressure drops and carryover)
- Low dead volume
- Withstands high pressure applications
- Withstands high temperature applications
- Chemically resistant resp. biocompatible (depending on the application)
- Overall compatibility of materials

After discussions with commercial players, the focus on microfluidic connectors should be set under the following conditions (the “hot-spot” in microfluidics):

- Temperature: 4 °C – 50 °C
- Pressure: < 2 bar
- Flow rate 1 µl/min -100 µl/min

- Water-based liquids containing biological materials

Although there are many applications that are outside this “hot-spot”, most of the microfluidic devices are operating in this “hot-spot”.

4. Connection types

There are a number of different connectors to choose from, depending on the type of device you want to connect them to. The guidelines will focus on microfluidic connectors to the following device types and components:

- Microfluidic chips made of glass
- Microfluidic chip made by injection molding
- Microfluidic components such as valves, pumps and sensors etc.

Valves, pumps and sensors can be connected by tubing or mounted on a manifold.

There are two main aspects of the connection of a device or components to a tube:

- The sealing aspect
- The force that holds the parts together

Generally, a structure is integrated on the chip that enables the mechanical connection of the tube:

- Luer-Lock or its miniaturized version Mini-Luer. This connection type has as disadvantages that it has a large dead volume and connectors created by different suppliers are not always compatible, especially Mini-Luer.
- “Hard” ferrule (e.g. SS, PEEK, PTFE). This is a very reliable way of connection, but the ferrules on the market are designed for high pressure applications and therefore rather expensive.
- Barbed hose. This connection type only works with soft wall tubes, that are not often used in microfluidics.

In all these cases friction force prevents tubing to disconnect.

Integration of such structures is relatively simple for injection molding devices, but in the case of glass chips, special structures need to be glued on the glass. Therefore glass chip suppliers prefer clamped connectors. The force to hold them together is applied by screws and the sealing (to prevent leakage) can be either O-rings or a gasket (e.g. silicone, FKM, FFKM) [1].

Alternatives for screwing have been proposed by researchers but are not commercially offered.

The most commonly used microfluidic connectors for each type of device and geometry are listed in Figure 1.

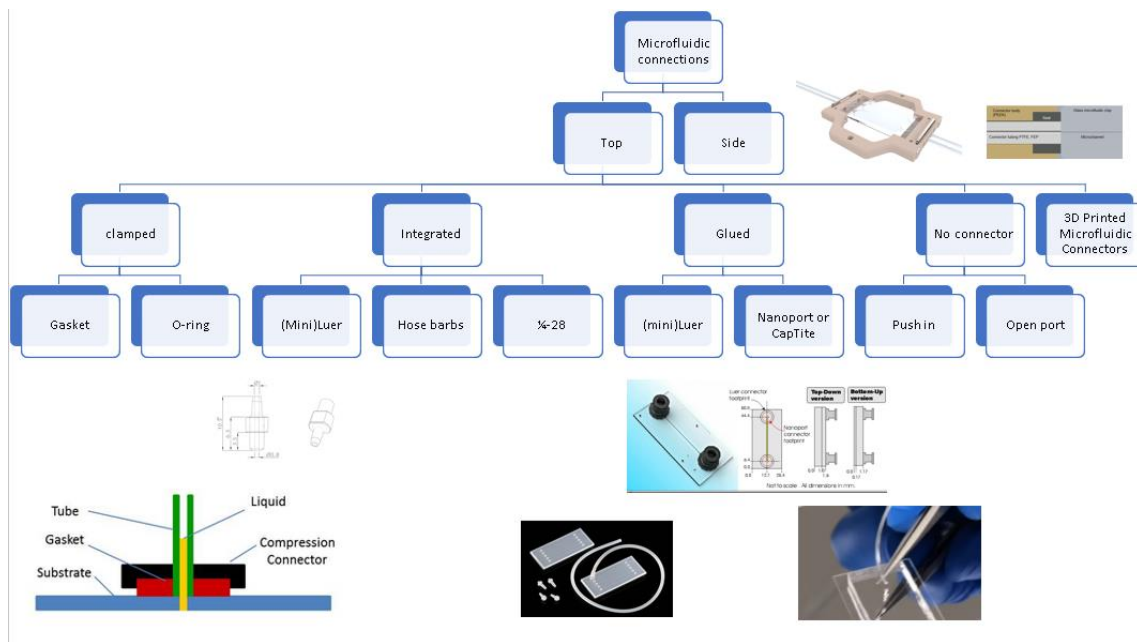

Figure 1: Overview of chip layout and connections for polymeric and glass devices (courtesy of enablingMNT).

4.1. Connectors for microfluidic chips made of glass

Microfluidic glass chips can be generally connected to the top or to the side as shown in Figure 2.

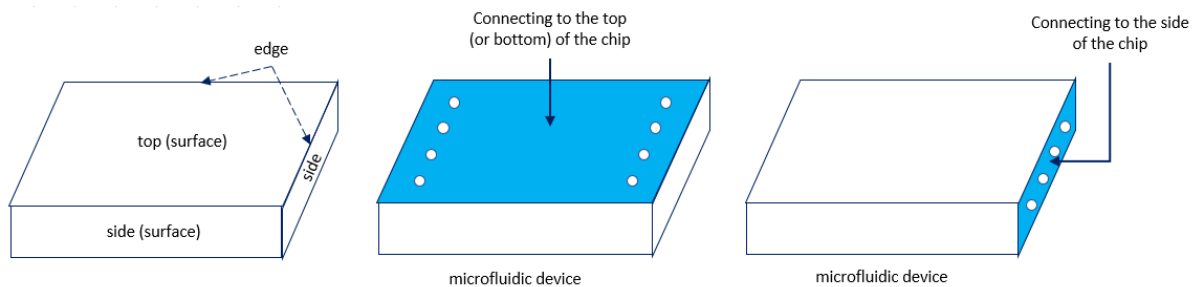

Figure 2: Schematics showing definitions of top, side and edge (left), top connection (middle) and side connection (right) [2].

4.1.1. Clamped connector fixed on top or bottom of the chip

This type of connector is covered by the standard ISO 22916 [3] and based on White Papers [4], [5]. Basically, the flattened surface of a tube is pressed against the flat surface of a chip.

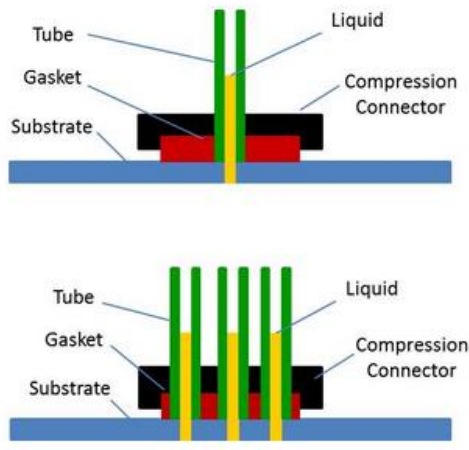

Figure 3: Sideview of a single (above) and multiple port gasket (below) connected to a glass surface. (courtesy CorSolution)

Using a gasket can prevent leakage and it offers further advantages [4], [5]: “The gasket approach does not use any adhesive, has zero dead-volume and is non-permanent. The connectors apply a user-defined compression force to a gasket, which seals both around the tube and to the substrate material, creating a zero dead-volume, leak-tight seal. Connections can be rapidly made (and removed) to almost any substrate material, and the gaskets are reusable. This approach is also amenable to automation where leak-tight connections to microdevices could be made robotically.” However, the gasket must be designed for each application, therefore the industry tends to use O-rings instead.

4.1.2. Flared connector to the side of the chip

This type of connector is described in the Whitepaper [2]. A big advantage of flared connectors is that several very reliable connections can be made in one step.



Figure 4: Flared fitting connection. The configurations of flared tubing assemblies are 1/16 - 1/8" OD plastic tubing such as PTFE, FEP, LDPE, or PEEK and with connections to 1/4-28, 10-32, M6, and 6-40 threaded ports.

4.1.3. Glued connectors

Several kind of ports can be glued to the chip, for instance: Luer, hose barb, IDEX NanoPorts™ or CapTite Bonded-Ports. This type of connector is very much suited for rapid prototyping, and is therefore often used in research. It allows to quickly iterate and test different designs before committing to a specific connector. . As this technology is more expensive and requires a time-consuming assembly it is not often used in the industry. This approach is also less reliable in terms of leakage.

4.2. Connectors for microfluidic chips made of polymer

Polymeric devices can be connected with injection molded components that fix the tubes to the port. These components can either be glued onto the chip, formed together with the chip by injection moulding or by screwing. There are different forms of these connectors:

4.2.1. Luer connectors

Luer connectors are the most used connectors and are a common choice for limited use or disposable applications. Originally, they were developed to connect the needles to the body of the syringe but have now found their way in several microfluidic accessories. There are two types: Slip-Luer and Lock-Luer, although only Lock-Luer is used in microfluidics. A male part is integrated on the microfluidic chip and can be attached to its counterpart by screwing it. This type of connection is not very safe for high pressures, also they have a high thread surface, meaning that components must be bigger and have a higher internal volume.



Figure 5: Luer connector.

To enable some miniaturisation the Mini-Luer is sometimes used, but this is not standardized and therefore risking incompatibility between suppliers.

4.2.2. Hose and barbed connectors

This type of connector is less commonly used and involves stretching a soft wall tube over a conical or cylindrical shaped device.

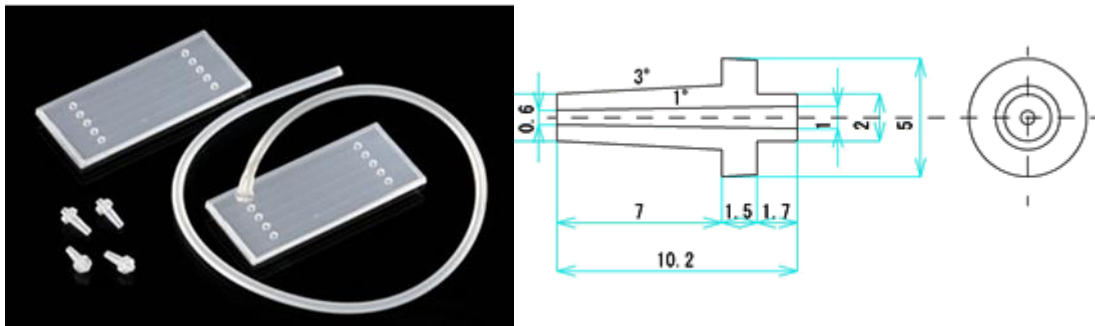

Figure 6: Plastic chip with hose connectors.

Similar to the Slip-Luer, barbed connectors only need to be pushed against the tubing to create a safe connection. Flexible tubing can be easily attached to this type of component, just make sure that the inner diameter of the tubing is compatible with the size of the fitting. No glue is needed. This type of fitting is suitable for low pressure applications.

4.2.3. Glued connectors

Glued connectors are used in the industry but requires a time-consuming assembly. Several kind of male or female parts can be glued to the chip, for instance: Luer, hose barb, IDEX NanoPorts™ or CapTite Bonded-Ports. Also, this approach is less reliable regarding leakage and is not durable.

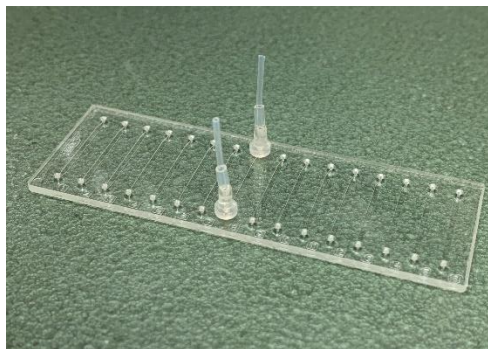

Figure 7: Glued hose barb connector to plastic chip.

4.3. Assembly of microfluidic connectors to standalone components

Here the diversity in connector types is very high. An indicative overview is given in Table 1:

Table 1: Overview of connectors used in microfluidics; X: used often, (X): used incidental.

| | Chips | | Pumps | | | | Other | | | | Comments |
|--|-------|---------|--------------------|-------------|----------|---------|-------------|---------------|--------|-------------------------------|---|
| | Glass | Polymer | Pressure regulated | Peristaltic | Membrane | Syringe | Flow sensor | Other sensors | Valves | Cell cultures / Organ on chip | |
| Barbed hose | | (X) | | | X | | | | X | X | Only with flexible tubing like silicone or PEEK |
| Mini-Luer | | X | X | | | X | | X | | X | Mostly Luer |
| Glued | (X) | | | | | | | | | | Labour intensive |
| 1/4-28 etc. | | | X | | | X | X | X | X | X | Mostly 1/4-28; can withstand higher pressures; generally used in gas chromatography and the chemical industry |
| Clamped using a gasket | X | X | | | | | | | | | Enables multiple connections made in one step |
| Manifold, docking station or chip holder | X | | | | | | | | X | (X) | Expensive |
| Other | | | (X) | | | (X) | | | | | Company specific, push in etc. |
| None | | | | X | | | | | | | Only with flexible tubing like silicone |

5. How to test connectors?

Key aspects of any microfluidic connector are:

1. No leakage under normal operational conditions [6]
2. Safety margin to pressure [6]
3. Low dead volume [7, 8]
4. Low flow resistivity [9]
5. Good mechanical fixture of the tube [10]
6. Aspects related to biocompatibility, cytotoxicity, chemical resistance, wettability [8]

The test procedure for aspect 1 and 2 are described in a White Paper [6].

There is no good test for dead volumes in microfluidic devices, though, for dead volumes in syringes a method is described in an ISO standard [12]. This method is weighing the syringe dry and after having been filled with, and emptied of, water. The dead space is inferred from the mass of the residual water. Emptying a microfluidic device is not trivial and it can be doubted if this method is accurate enough for microfluidic devices.

Flow resistivity can be measured according to a White Paper produced by MFMET [9].

A procedure to test the mechanical fixture of the tube is given for Luer connectors in an ISO standard [10]. This procedure might need changes for microfluidic connector testing.

5. Selection of types, geometries and dimensions

After several discussions, the members of the MFMET project decided to concentrate on testing the following connectors, which were available at the time of testing:

- Clamped connector
- (mini)Luer connector
- Hose connector
- Glued connectors

The popularity of these connection types was the main motivation for this selection.

Materials for tubing can be categorized as either flexible or rigid [13, 14]. Typically, soft-walled flexible tubes are employed with peristaltic pumps or when specific connectors, such as barbed hoses, are in use. Even though rigid tubes come with a higher price tag compared to flexible ones, they offer greater durability and are less prone to damage. These rigid tubes are particularly suitable for specialized tasks. However, their bulkier nature makes them more challenging to set up. Due to their adaptability, flexible tubes are ideal in situations requiring a high concentration of tubes in one space. It's important

to note that peristaltic pumps specifically require flexible tubing. A common tube size has an outer diameter of 2 mm. Yet, for microfluidic applications, hard-walled tubing is the preferred choice. Such tubes are offered in many sizes, but the most used versions for microfluidics are hard wall tubes with the following outer diameter dimensions:

- 1/16" (≈ 1.6 mm)
- 1/32" (≈ 0.8 mm)

Slightly less often used:

- 0.5 mm (usually between 0.44-0.53 mm)

The size of the inner dimension is to be chosen according to requirements (channel size, no pressure loss, smooth transition, etc).

5.1. Towards a standard microfluidic connector

As seen above, it is likely that a clamped connector can be used for all microfluidic chips (glass and polymer). Unfortunately, the situation is more complex for microfluidic devices and components like pumps, valves, etc. The diversity in connection systems used is large, making it difficult for users to connect the available off-the-shelf devices and components.

In order to come to an agreement about how to connect these components to each other, actions are needed in the following areas:

- A list of performance parameters behind integration / combination of microfluidic components / devices for instance: pressure-, temperature- and flow ranges etc.)
- Agreement on the most important performance parameters behind integration / combination of microfluidic components / devices
- Formulation of well-defined classes of microfluidic products that share these performance parameters and identify the most requested classes
- Agree on metrology to support these classes
- Set requirements for microfluidic connection systems per class
- Agree on a favoured connection system per class

In a cooperative effort of MFA and MFMET, a discussion group with microfluidic experts from the following companies was formed in order to define a standard microfluidic connector:

- 1) Takasago (pumps and valves)
- 2) Memetis (valves)
- 3) Bartels (pumps)
- 4) Siargo (flow sensors)
- 5) Bronkhorst (flow sensors and mass flow controllers)
- 6) Sensirion (flow sensors and mass flow controllers)
- 7) Burkert (pumps and valves)
- 8) Fluigent (flow control system)
- 9) Imconnect (OEM test systems)
- 10) Blacktrace (microfluidic products)
- 11) Elvesys (flow control system)
- 12) IST-AG (physical, chemical and biological sensors)
- 13) Darwin Microfluidic (microfluidic products)
- 14) Micronit (glass chip manufacturer)

6. Compatibility tests with connections and components

In addition to gluing connectors onto a chip, glass chips often use clamping systems to connect to tubing, whereas molded plastic devices often use mini-Luers (Figure 7). This section introduces commonly used connectors, their size and location on commercially available devices. Although several chip sizes are used in microfluidics, substantial numbers of commercial microfluidic devices have the exact outer dimensions of standard microscope slides and microtiter plates.

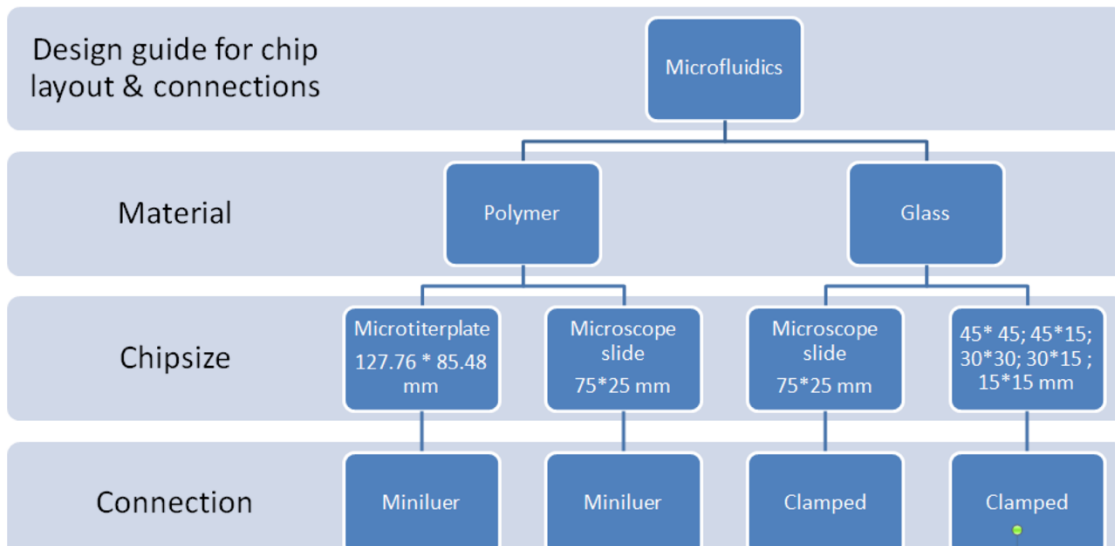

Figure 7: Overview of chip layout and connections for polymeric and glass devices (courtesy of enablingMNT).

6.1. Glass chips

Commercially available glass chips often use clamped interconnections, mostly from the top. Different companies have different sized chips and thus offer their clamp systems, which generally use a gasket (or O-ring) to form a tight seal (Figure 8). The chip can be held against the connector via different mechanisms, including:

- Screw tightening
- Magnet holding
- Spring-loaded clamping
- Hooks

Furthermore, there are different outer dimensions, spacing between ports, port size and tubing size. An important advantage of clamped connectors, compared to mini-Luer based connections, is the low dead volume of the microfluidic path and the ability to make several interconnections at the same time, for instance, by using chip holders. Dead volume poses a detrimental threat in microfluidic operation as it creates regions where air bubbles or compressible gas can trap. These air pockets can lead to bubble release and flow pulsing due to the presence of compressible gas in the flow path.

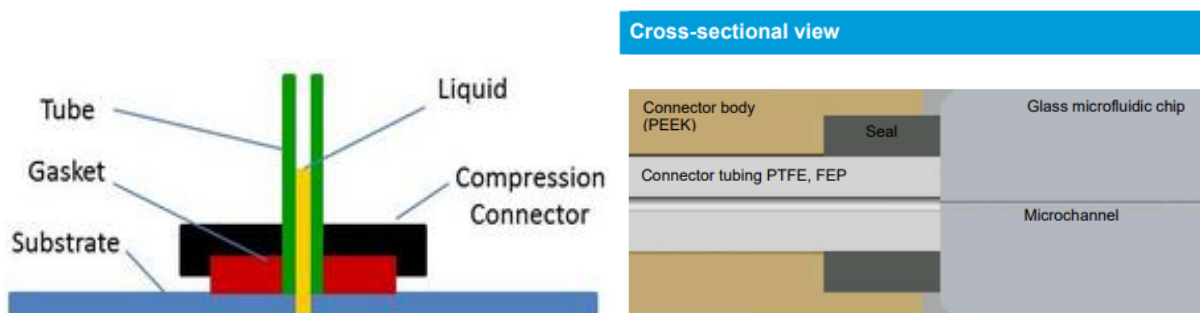
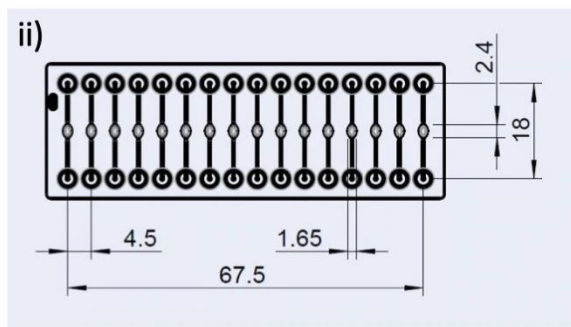

Figure 8: Schematic drawing of clamped connectors; left: top connection [7], right: side connector [8].

6.2. Molded plastic chips

Most thermoplastic chips have dimensions of a standard microscope slide (75.5 mm x 25.5 mm x 1.5 mm) or microtiter plates (85.48 mm x 127.76 mm). Mini-Luers or Olive ports are commonly used, as shown in Figure 9. They can be either glued on the chip or integrated directly on the chip during molding. Mini-Luers are normally placed on the borders of the chip with a pitch of 4.5 mm (or 9 mm for Luers) according to the positions of the outer walls of the standard layout (Figure 10). The most common port size is 1.5 mm, which is normally linked with a flexible tubing (e.g. silicone, Tygon) ($0.5 \text{ mm} < \text{ID} \leq 1.0 \text{ mm}$) or a silicone sleeve ($0.5 \text{ mm} < \text{ID} \leq 1.0 \text{ mm}$) plus rigid tubing (e.g. PTFE, PEEK) ($\text{OD} > \text{ID of sleeve}$) (Figure 10 (B) and Figure 11). However, there is limited information on the choice of tubing for commonly used connectors and the tolerance of a combination for leak-free operation under different pressures.

(A)



(B)

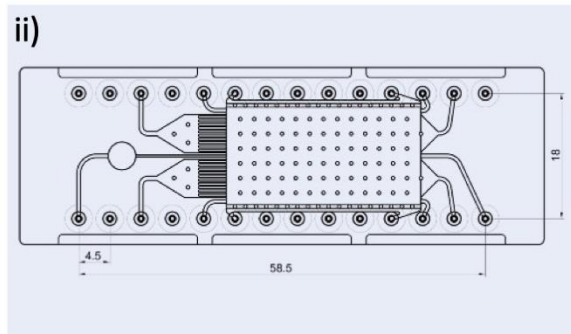
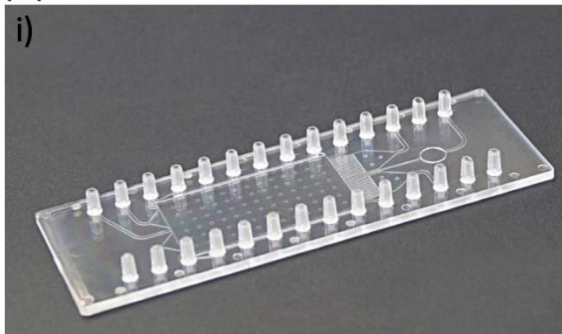

Figure 9: Typical plastic chip with moulded connectors. (A) mini- Luer and (B) Olive port connectors. i) Layout of the chip and ii) dimension of port and spacing. Devices were provided by Microfluidic ChipShop.

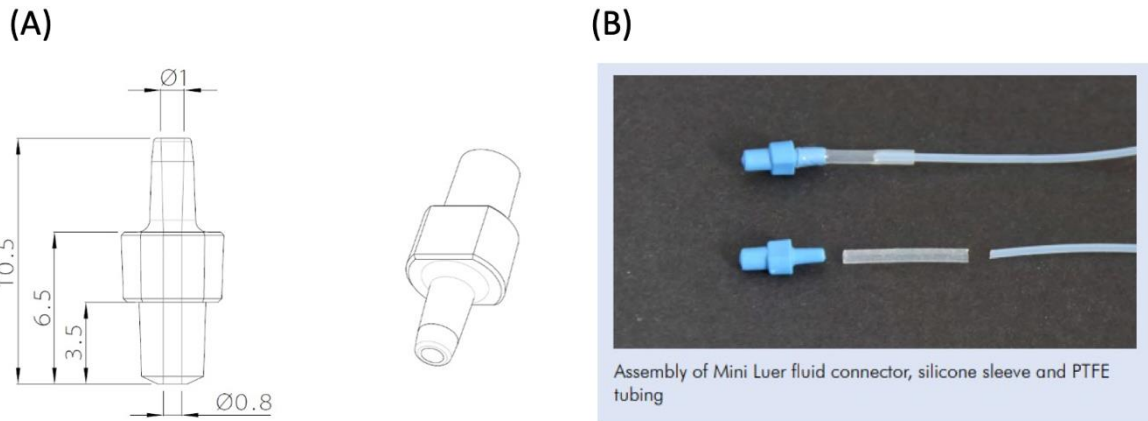

Figure 10: (A) Dimension of a male mini-Luer connector and (B) tubing connection to mini Luer (courtesy of Microfluidic ChipShop).

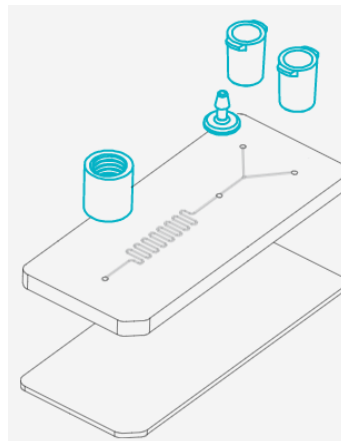

Figure 11: Schematic drawing of typical device from Parallel Fluidics with connector options highlighted from top to bottom: two Luer connections, a barbed fitting and a threaded flat bottom fitting [8].

Although Luer connector dimensions and other specifications are fixed according to an official standard [15], mini-Luers are not described in a standard. As a consequence, mini-Luers from different suppliers are not always compatible.

6.3. Documented example

Several tests were performed to investigate the compatibility of various components for 3 different chips assemblies, in order to ensure the traceability of dimensional measurements to primary standards. The assemblies are presented below. At the time of the test protocol, no glass chips could be provided yet. The golden standards, which are planned to be produced during the running time of the MFMET project and will consist of glass and polymeric chips, will also be tested at a later date.

6.3.1. PDMS chip

A PDMS chip was provided by INESC and tested for assemblies with different components.

- a) Chip – 1 (see Figure 12): channel with two $\varnothing 0.9$ mm inlet holes; dimensions: 40mm x 10 mm

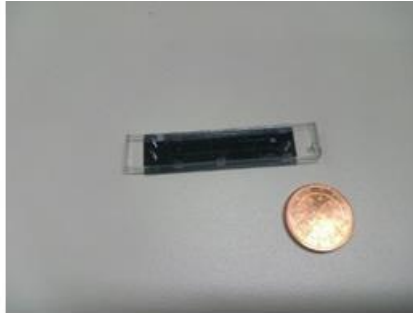

Figure 12: Chip – 1.

- b) Stainless steel catheter plug (see Figure 13): outer diameter $\varnothing 0.9$ mm; length of 12 mm (by Instech).



Figure 13: Stainless steel catheter plug.

- c) Connecting soft tube (see Figure 14): polyethylene tube with a length of 59 cm long; inner diameter of 0.9 mm; material: BTPE-90 (by Instech Laboratories).

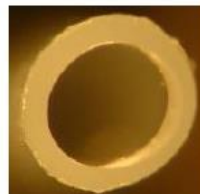

Figure 14: Connecting tube.

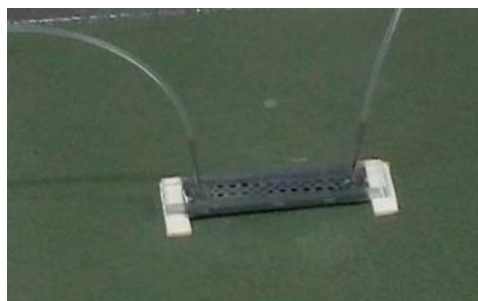

Figure 15: Assembly of all components together (chip – 1, catheter plug and connecting tube).

6.3.2. Topas chip (A)

A polymeric chip made of Topas was provided by Microfluidic ChipShop and tested for assemblies with different components.

- a) Chip (A) (see Figure 16): parallel channel array with fluid interface holes; material: TOPAS® (COC polymer for medical use); dimensions: 75.5mm x 25.5mm x 1.5mm; model 10000198 with Lot no. Z1112070.

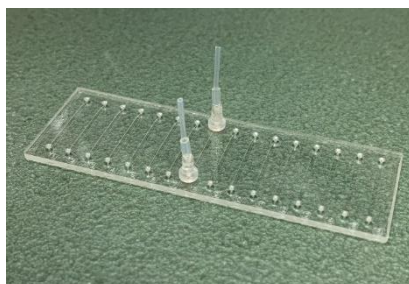

Figure 16: Topas chip (A).

- b) Connector (see Figure 17): material: opaque polypropylene (PP); model 10000700 with Lot no. FA127725.



Figure 17: Connector provided by Microfluidic ChipShop.

- c) Rubber tube (see Figure 18): material: silicone; inner diameter: 0.76 mm; external diameter: 1.65 mm; model 10000031.

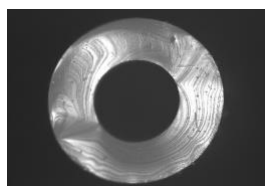

Figure 18: Rubber tube.

d) Complete assembly of Topas chip (A) (Figure 19).

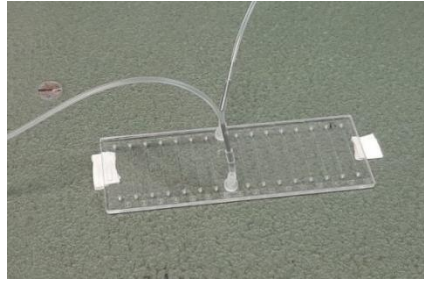

Figure 19: Assembly of all components together (Topas chip (A), PP connector, silicone tube, connecting tube and catheter plug).

6.3.3. Topas chip (C)

Another polymeric chip made of Topas was provided by Microfluidic ChipShop and tested for assemblies with different components.

- a) Chip (C) (see Figure 20): parallel channels with mini Luer fluidic interface; material: TOPAS® (COC polymer for medical use); dimensions: 75.5mm x 25.5mm x 4mm; model 10000168; Lot no. JI125176.



Figure 20: Topas chip (C).

- b) Connector (see Figure 21): material: opaque polypropylene (PP); model 10000094; Lot no. FF115266.



Figure 21: Connector provided by Microfluidic ChipShop.

- c) Complete assembly of Topas chip (C) (see Figure 22).

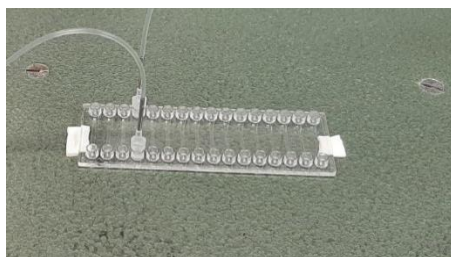

Figure 22: Assembly of all components together (Topas chip (C), PP connector, silicone tube, connecting tube and catheter plug).

6.3.4. Dimensional measurements

The dimensions of all chip components were measured using a three-dimensional optical measuring machine (3D MMO) or profile projector, brand Mitutoyo Quick Vision, resolution 0.0001 mm (see Figure 23). This equipment includes a computational application, Mitutoyo Mitac Qvpack, version 7.401A, which ensures the virtual construction of geometric elements (lines, circles, among others) necessary for the measurement of dimensional and geometric quantities of interest. It also has its own artificial lighting system, which can be adjusted to observe opaque and translucent objects with differentiated photometric characteristics.

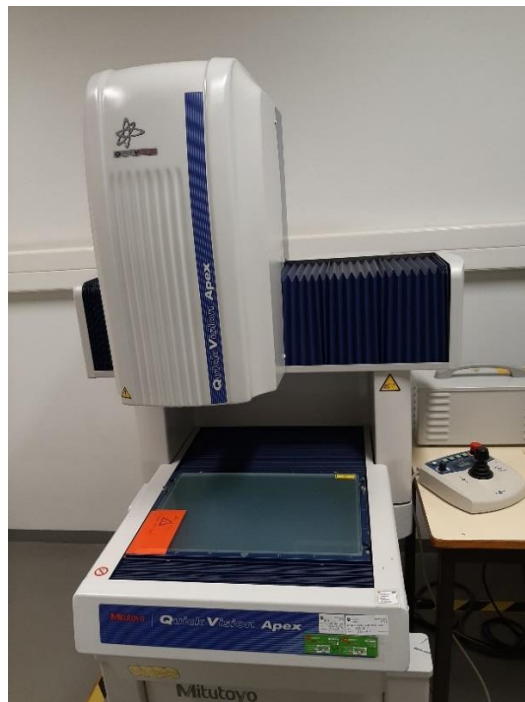

Figure 23: 3D optical measuring machine from Mitutoyo Quick Vision.

Further measurements were also performed using interferometry (see Figure 24).

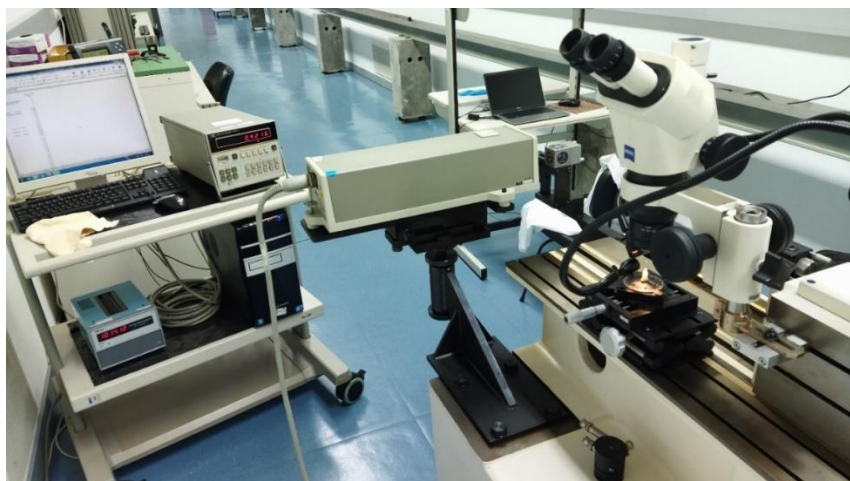

Figure 24: Interferometer from HP, model 5528A, resolution 0,00001 mm.

Both three-dimensional optical measuring machines and interferometers are advanced tools used for precision measurements. It should be noted that while both tools can provide extremely precise measurements, the specific capabilities and resolutions might differ based on the particular model, design, or setup of the equipment.

6.3.5. Results

The obtained results for the 3 different assemblies using different methods are shown in the following from Figure 25 to Figure 29.



Figure 25: Dimensions measured using the interferometer for the PDMS chip; the assembly is shown in Figure 15.

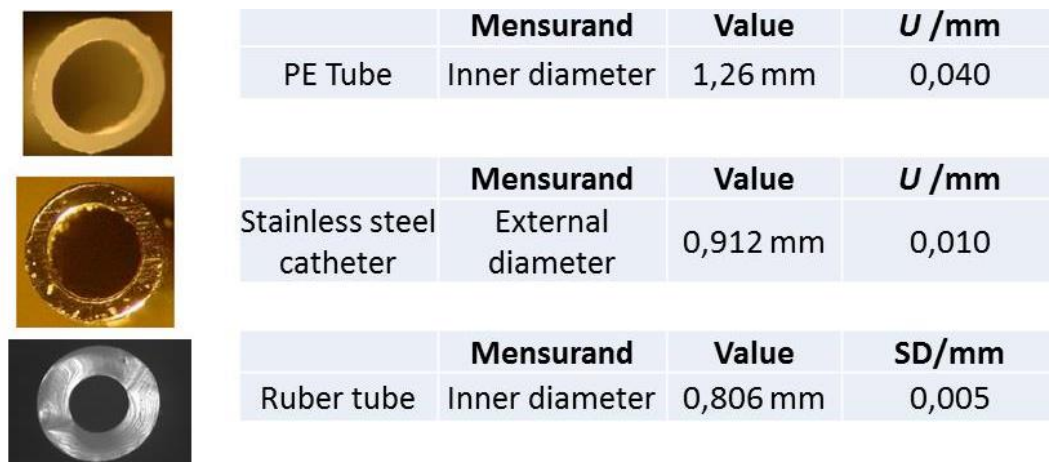

Figure 26: Dimensions measured using the interferometer for the Topas chip (A); the assembly is shown in Figure 16.



| | | | | |
|---|----------------------|------------------|--------------|--------------|
|  | | Mensurand | Value | U /mm |
| Ruber tube | Inner diameter | 0,820 mm | 0,039 | |
|  | | Mensurand | Value | U /mm |
| Connector | External diamter top | 1,77 mm | 0,44 | |
|  | | Mensurand | Value | U /mm |
| Hole in the Chip | DInner diameter | 1,384 mm | 0,038 | |

Figure 27: Dimensions measured using the 3D machine for the Topas chip (A); the assembly is shown in Figure 16.

| | | | | |
|---|-----------------------|------------------|--------------|---------------|
|  | | Mensurand | Value | U /mm |
| PE Tube | Inner diameter | 1,26 mm | 0,040 | |
|  | | Mensurand | Value | U /mm |
| Stainless steel catheter | External diameter | 0,912 mm | 0,010 | |
|  | | Mensurand | Value | SD /mm |
| Connector | Small inner diameter | 0,93 mm | 0,11 | |
| | Big external diameter | 2,577 mm | 0,012 | |
|  | | Mensurand | Value | SD /mm |
| Hole in the chip | Inner diameter | 2,883 mm | 0,007 | |

Figure 28: Dimensions measured using the interferometer for the Topas chip (C); the assembly is shown in Figure 19.

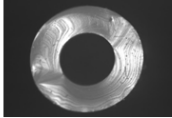

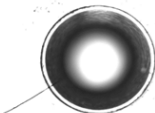
| | Mensurand | Value | U /mm |
|-----------|-----------------------|---------|---------|
| Connector | Big external diameter | 2,78 mm | 0,18 |

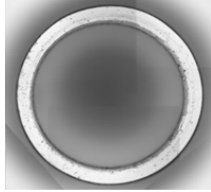

| | Mensurand | Value | U /mm |
|------------------|----------------|----------|---------|
| Hole in the chip | Inner diameter | 2,843 mm | 0,019 |

Figure 29: Dimensions measured using the 3D machine for the Topas chip (C); the assembly is shown in Figure 19.

6.3.6. Discussion and conclusions

In the length measurements, the measured values (estimation of the length measurands) and the uncertainties obtained with the two methods used, interferometer and 3D MMO profile projector, are compatible since they are within the mutual uncertainty values.

In the case of interferometry, the definition of the measurement plane of the accessories in translucent material presented a technical difficulty due to the equipment available. For these measurements, only the standard deviation of the measurements was given.

Shape deviations inherent to the accessories (roundness, cylindricity) of the plastic material are identified as the main factors for the high value of the standard deviation found (of the order of 0.01 mm when the interferometer has a resolution of 0.01 μm).

The shape deviations and the plasticity of the constituent material of the tubes and connectors make it very difficult to measure with high accuracy when using the interferometer and also to assure traceability to SI units, this is why only the standard deviation and not the uncertainty was provided for these measurements.

Using the 3D MMO profile projector, it was possible to calculate the uncertainties obtained and images of all the accessories, even the translucent ones, therefore the traceability was assured by using calibrated gauges. In general, the uncertainty values are larger for the 3D MMO than the standard deviation declared for the interferometer.

It can be verified that on the Topas chip (C) the outer diameter of the connector is smaller than the inner diameter of the hole in the chip and this means that these components are not compatible and may lead to leakage.

Flow tests were performed in each chip assembly using the front track method and the gravimetric method. The results are in Appendix and confirm the connection problem in the Topas chip (C), where a leakage can be found in both methods. For the gravimetric method the flow coming out from the chip is substantially smaller than the one generated by the pump. In case of the front track method the situation is even more evident due to the negative values, that means that no flow came out of the chip and the meniscus was moving in the opposite direction of the flow, this is the reason of negative flow values.

Injection moulded COC/COP devices appear to be more uniform, mainly having the outer dimensions of a standard microscope slide or microtiter plate, 1.5 mm port size, and mini-Luers with a pitch of 4.5. It is usually connected to flexible tubing (or sleeve).

In conclusion, the following recommendations for metrological measurements can be drawn from the results:

- Measure the dimensions of a microfluidic channel to evaluate the stability and accuracy of the microstructures (especially for injection moulded devices) using the appropriated methods.
- Measure the flatness of injection moulded devices.
- If an enclosed device is formed using an adhesive layer, measure changes in optical transmission, reflection and/or autofluorescence.
- Measure the diameter and tolerance of tubing that can form a tight fit under different pressures.

7. Established solutions in commercial systems

For comparison we have tried to find out from publicly available sources, how the interfacing challenge was solved in commercially available instruments. Commercially available microfluidic systems mostly use the gasket approach. Often this is combined with reservoirs that allow sample introduction by pipetting, because that fits ideally into classic workflows in the life science industry. While the microfluidic chips in the academic environment are often “naked”, they are typically loaded in cartridges in industrialized applications. A cartridge allows improved ease of handling as well as providing space for protocol, part and sample IDs. All of these solutions are highly specific for the instruments they are built for. For a standardisation approach the ideas and experience from these solutions should be considered, but the main focus should be on versatility. Furthermore, standardisation is most important for the design and development phase of new instruments. Therefore standardized interfacing solutions should be feasible for high volume as well as for low volume and even single experiment applications.

Some examples of commercial systems are given below:

- Stilla naica system
 - Application: Digital PCR
 - Material: Polymer
 - Interface: Pipetting into reservoirs
 - Source: <https://www.stillatechnologies.com/multiplex-pcr/digital-pcr-reagents/>



- Biorad automated droplet generator
 - Application: Droplet digital PCR
 - Material: Polymer
 - Interface: Polymer Sealings to pipetting system
 - Source: <https://www.bio-rad.com/sites/default/files/webroot/web/pdf/lsr/literature/10043138.pdf>



- 10X Genomics:
 - Application: Single Cell Gene Expression and more
 - Material: Polymer
 - Interface: Pipetting and rubber gasket over well edges
 - Source: <https://www.10xgenomics.com/instruments/chromium-x-series>

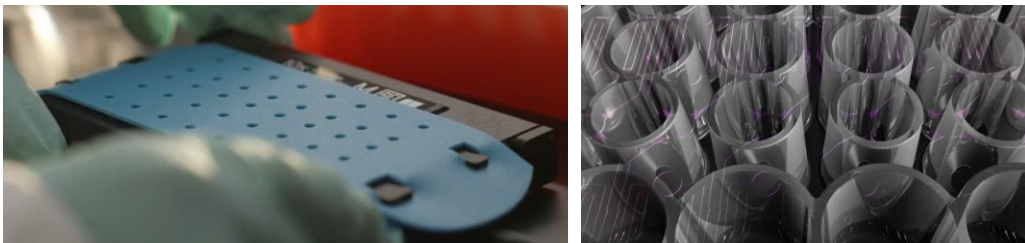

- Agilent 2100 Bioanalyzer:
 - Application: gel electrophoresis
 - Material: Glass chip in polymer cartridge
 - Interface: Inside cartridge – unknown; cartridge to machine: conical seals on cartridge, electrical interface: Pins in holes
 - Source: <https://www.agilent.com/cs/library/posters/Public/BioAnalyzer.PDF>



- Kilobaser:
 - Application: DNA / RNA Oligo Synthesis
 - Material: Polymer
 - Interface: Through surface holes with elastic polymer sealings
 - Source: <https://kilobaser.com/technology/>



- Illumina NovaSeq X:
 - Application: Sequencing
 - Material: Glass
 - Interface: Through surface Holes Clamped on O-rings with Cartridges
 - Source: <https://www.youtube.com/watch?v=s5p0JpR6QfY&t=8s> and <https://www.illumina.com/systems/sequencing-platforms/novaseq-x-plus/applications/broad-sequencing.html>



References

- [1] Henne van Heeren: “Report of the 5th Workshop Microfluidic Standardisation”, March 2019, Lisbon
- [2] Henne van Heeren, Wilfred Buesink: “Design Guidelines for Microfluidic Side Connect” (version 1)
- [3] ISO 22916:2022, Microfluidic devices — Interoperability requirements for dimensions, connections and initial device classification
- [4] Henne van Heeren et al.: “Design for Microfluidic Interfacing”, White Paper part 1 (version 3)
- [5] Henne van Heeren et al.: “Design for Microfluidic Interfacing”, White Paper part 2 (version 3)
- [6] Henne van Heeren: “Protocols for leakage testing”, DOI: 10.5281/zenodo.6602162
- [7] <https://www.fluigent.com/resources-support/expertise/expertise-reviews/concepts-and-physics-of-microfluidics/microfluidic-volume-definitions>
- [8] <https://darwin-microfluidics.com/blogs/reviews/internal-volume-swept-volume-dead-volume-in-microfluidics>
- [9] Mikkel Copeland, Florestan Ogheard, Elsa Batista, Henne van Heeren: “Whitepaper flow resistivity testing”, DOI: 10.5281/zenodo.7919134
- [10] ISO 80369-20, Small-bore connectors for liquids and gases in healthcare applications — Part 20: Common test methods
- [11] Henne van Heeren: “Whitepaper on the measurement of hydrophobicity, hydrophilicity, and wettability”, DOI: 10.5281/zenodo.7181091
- [12] ISO 7886-1, Sterile hypodermic syringes for single use — Part 1: Syringes for manual use; annex C
- [13] <https://www.elveflow.com/microfluidic-reviews/general-microfluidics/the-basics-of-microfluidic-tubing-sleeves/>
- [14] <https://www.fluigent.com/resources-support/expertise/expertise-reviews/elements-of-a-microfluidic-system/microfluidic-tubing/>
- [15] ISO 7886-2:2020, Sterile hypodermic syringes for single use — Part 2: Syringes for use with power-driven syringe pumps
- [16] Figure adapted from <https://www.mycorsolutions.com/fitting-and-connector-tutorial.html>
- [17] Figure adapted from <https://www.dolomite-microfluidics.com/>
- [18] Figure adapted from <https://www.parallefluidics.com/>

8. Appendix

8.1. Flow measurement results for the 3 chip assemblies using the gravimetric method

| Gravimetric method | | | | | |
|--------------------|----------------------|-------------------------|-----------|-------|---------------------------|
| Chip | Generated Flow(mL/h) | Out Flow of chip [mL/h] | Error [%] | U (%) | Measurement time steps[s] |
| INESC MN | 0,001 | 0,00092 | 8 | 23 | 30 |
| | 0,1 | 0,0993 | 0,7 | 4,6 | 30 |
| | 0,1 | 0,0993 | 0,7 | 2,5 | 30 |
| | 1 | 0,9945 | 0,55 | 2,4 | 30 |
| A | 0,01 | 0,0099 | 1,0 | 5,0 | 15 |
| | 0,1 | 0,0983 | 1,7 | 3,8 | 15 |
| | 1 | 0,9907 | 0,93 | 0,19 | 15 |
| C | 0,01 | 0,0069 | 31 | 5 | 30 |
| | 0,1 | 0,097 | 2,6 | 3,4 | 30 |
| | 1 | 1,017 | -1,7 | 3,0 | 30 |



8.2. Flow measurement results for the 3 chip assemblies using the front rack method

| Front track method | | | | | |
|--------------------|----------------------|-------------------------|-----------|-------|--------------------------|
| Chip | Generated Flow(mL/h) | Out Flow of chip [mL/h] | Error [%] | U (%) | Measurment time steps[s] |
| INESC MN | 0,001 | -0,0014 | -170,8 | 14,0 | 10 |
| | 0,01 | 0,0113 | -11,8 | 3,3 | 10 |
| | 0,1 | 0,0961 | 4,0 | 2,6 | 10 |
| | 1 | 1,0257 | -2,5 | 4,0 | 10 |
| A | 0,01 | 0,0095 | 5,3 | 3,7 | 10 |
| | 0,1 | 0,0967 | 3,4 | 2,8 | 10 |
| | 1 | 0,9819 | 1,8 | 6,2 | 5 |
| C | 0,01 | -0,0033 | -402,8 | 43,3 | 10 |
| | 0,1 | 0,0996 | 0,5 | 1,9 | 10 |
| | 1 | 1,0259 | -2,5 | 4,0 | 5 |

