

AI Algorithm Based Green Hydrogen Static Compensator for Harmonic Mitigation, Power Balancing, and Power Factor Correction in Nano-Grids

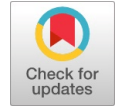

T. Ruban Deva Prakash, Achshah R M

Abstract: Nano-grids are emerging as a vital solution for sustainable energy distribution, particularly in integrating intermittent renewable energy sources. In this context, this research paper aims to address the challenges faced in Nano-grids through the innovative use of a Green Hydrogen Static Compensator (GHSC). The purpose of this study is to overcome issues related to harmonic pollution, power factor correction, and real power balancing within the Nano-grid system. The method employed involves a two-fold approach. Firstly, a modified instantaneous p-q algorithm is proposed to enhance the effectiveness of GHSC. Secondly, artificial intelligence (AI) algorithms, including deep neural networks, random forest, and XGBoost, are utilized to further refine the system's accuracy. These AI algorithms were trained using the modified p-q method, and the simulation of GHSC was performed using SimScape Toolbox in MATLAB-Simulink. The results of the study clearly demonstrate that the proposed GHSC approach, combined with the AI algorithms, outperforms traditional methods in terms of effectiveness in mitigating harmonic pollution and correcting power factors. However, it is noted that the current implementation lacks flexibility for real-time self-learning. In conclusion, the paper underscores the novelty and potential of the GHSC in conjunction with AI algorithms, while also pointing out areas for future research. Specifically, future efforts may focus on developing an automatic weight updating deep neural network that responds to real-time feedback of THD, power factor, and frequency, enhancing the system's adaptability and efficiency.

Keywords: Artificial Intelligence, Green Hydrogen Energy Storage, Nano-grid, Power Quality, Static Compensator

I. INTRODUCTION

Nano-grids offer a sustainable and reliable solution for meeting the increasing demand for electricity while reducing the impact of fossil fuels on the environment. The reliability and efficiency of the operation of the electrical equipment is ensured by the electric power quality, which is a crucial component of modern nano-grids.

Manuscript received on 23 November 2023 | Revised Manuscript received on 29 November 2023 | Manuscript Accepted on 15 December 2023 | Manuscript published on 30 December 2023.

*Correspondence Author(s)

Dr. T. Ruban Deva Prakash*, Post Doctoral Researcher, International Innovation Program, Eudoxia Research University, USA. (Principal, JKKN College of Engineering and Technology, Komarapalayam, Namakkal, India. Email: hcetprincipal76@gmail.com, ORCID ID: <https://orcid.org/0000-0001-7475-5607>

Achshah R M, CEO, Effigies Smart Technologies LLP, Kanyakumari, India. E-mail: samuellachsha108@gmail.com, ORCID ID: [0000-0002-9043-8019](https://orcid.org/0000-0002-9043-8019)

© The Authors. Published by Blue Eyes Intelligence Engineering and Sciences Publication (BEIESP). This is an open access article under the CC-BY-NC-ND license <http://creativecommons.org/licenses/by-nc-nd/4.0/>

Harmonic pollution and power factor issues have significantly increased in recent years because of the growing usage of non-linear loads and inductive loads in nano-grid systems. These issues have several adverse repercussions, including equipment damage, energy losses, and higher electricity costs. Numerous solutions, including conventional ones like instantaneous active and reactive power (p-q) methods and cutting-edge ones like artificial intelligence (AI) algorithms, have been developed to address these problems. Additionally, integration of intermittent energy sources like solar and wind electric generators causes power imbalance which leads to power oscillations and poor voltage regulation. These problems must be addressed to ensure the efficient and sustainable integration of renewables in nano-grids. The potential of hydrogen in decarbonizing sectors that have been challenging to address with other clean energy solutions makes it an important component of the transition to clean energy. To fully understand its contribution, it is essential to evaluate its applications on a case-by-case basis and consider it as a complementary solution to other climate change mitigation strategies. Green Hydrogen is a promising option that can be used for long-term storage of renewable energy, substituting fossil fuels in industrial processes, clean transportation, and potentially even for distributed power generation, aviation, and marine transport. The problem statement involves addressing the challenges associated with the integration of renewable energy sources in nano-grids, which include power oscillations, harmonic pollution, and low power factor due to non-linear and inductive loads using Green Hydrogen. The traditional solution of using the instantaneous p-q algorithm with DSTATCOM to solve these issues does not address the power imbalance arising from the intermittency of renewable sources. To address this limitation, the paper proposes a modified instantaneous p-q algorithm that provides real power support from the battery energy storage system (BESS) of Green Hydrogen Static Compensator (GHSC) to balance real power with frequency feedback. However, during simulation, it was found that this method was not effective in terms of speed of response, accuracy, flexibility, computation complexity, energy efficiency, and cost. To overcome these limitations, the paper proposes using artificial intelligence (AI) algorithms, including transformer architecture deep neural networks, random forest, and XG Boost, to improve the accuracy and effectiveness of GHSC in reducing harmonic pollution, correcting power factor, and balancing real power. The deep neural network algorithm was found to be the most effective, with an accuracy score of 99%.

AI Algorithm Based Green Hydrogen Static Compensator for Harmonic Mitigation, Power Balancing, and Power Factor Correction in Nano-Grids

The performance comparison of GHSC with the modified instantaneous p-q method and AI algorithms were studied, and it was found that the deep neural network outperformed the other algorithms. However, the algorithm lacked flexibility in terms of real-time self-learning for self-improvement of efficiency and effectiveness.

The proposed approach can be further improved by developing an automatic weight updating deep neural network based on real-time feedback of THD, power factor, and frequency. The key results of the study are the effectiveness of the proposed approach and the potential for further improvement through future research. In the next section, the current state of art and research methodology are discussed. In the further sections the proposed modification in instantaneous p-q method, AI algorithms and GHSC is explained. Finally, the results of conventional technique and proposed methods are evaluated and conclusion are drawn.

II. CURRENT STATE OF THE ART

The rapid growth of renewable energy integration has led to an increase in the demand for efficient and reliable power management systems in modern power grids, presenting challenges such as power balancing, power factor correction, and harmonic distortion. Various traditional and modern techniques have been proposed to address these challenges. For instance, Eko Adhi Setiawan and Adita propose the use of Dual Power Nano-grids to ensure stable voltage during dynamic loads [6]. Meliani et al. [9] and Giuseppe Barone et al. [8] recommend demand response and renewable energy communities to balance supply and demand and address power balancing challenges. De Oliveira et al. emphasize the importance of power quality and propose a microinverter with a parallel active filter for harmonic suppression [4]. Traditional techniques like the instantaneous active and reactive power method have been used, but they suffer from lag in response, complexity, and accuracy issues. Researchers such as Sunil Kumar et al. [13], Frifita and Boussak [7], and Dovgun et al. [5] have proposed novel solutions based on this concept to enhance power factor correction and damping harmonic resonance.

Regarding power quality mitigation devices, Benavides-Córdoba et al. compared DSTATCOM with a three-phase capacitor for reactive power compensation [2]. Rohani et al. [12] proposed robust schemes for DSTATCOM against harmonics, while Prakash and Senthil Kumar presented an approach for ESTATCOM-based wide area controllers [11]. The application of AI-based techniques like ANN, random forest, and XGBoost has shown potential. Akpolat et al. demonstrated the effectiveness of ANN-MPC control for PV-battery-based microgrids [1][14][15][16]. Dana Ragab and Jasim Ghaeb utilized AI for voltage unbalance mitigation [3], and Naaz and Channegowda used XGBoost methodology for battery parameter generation [10][17][18]. This literature review provides insights into the application of these techniques in the design and control of Electrical Static Compensator (ESTATCOM) for harmonic mitigation, power balancing, and power factor correction in renewable-integrated nano-grids. The review compares the performance of the Instantaneous P-Q method and Artificial Intelligence-based algorithms, highlighting the potential of these

approaches to overcome traditional techniques' limitations. The study aims to explore the efficacy of AI algorithms compared to conventional methods and develop an efficient and lightweight GHSC device to address renewables' intermittency issues in nano-grids. The research questions are:

RQ1: Can AI algorithms outperform the instantaneous active and reactive power method in mitigating harmonic pollution and correcting power factor?

RQ2: What are the advantages and limitations of AI algorithms versus conventional methods?

RQ3: Can an efficient device replace DSTATCOM and ESTATCOM, providing real and reactive power support in nano-grids?

III. OVERVIEW OF NANO-GRID WITH PROPOSED GHSC

[Fig. 1](#) illustrates the architecture of a nano-grid that incorporates a proposed control system. The nano-grid is composed of a solar generation system with a maximum power point tracking (MPPT) based DC/AC converter, as well as an AC wind electric generator with a built-in AC/AC converter. The loads in the nano-grid are classified into three categories: critical load, schedulable load, and normal load. To enhance the performance of the nano-grid, a proposed Green Hydrogen Static Compensator (GHSC) system is also integrated. This control system is designed to address power oscillation, harmonic pollution, and power factor improvement. It functions by mitigating the effects of power oscillation, which can result from the intermittent nature of renewable energy sources by feeding and absorbing real power using Green Hydrogen production and storage mechanism of GHSC. Additionally, the GHSC system helps to reduce harmonic pollution, which can result from the non-linear loads connected to the grid. Finally, it improves the power factor of the nano-grid, which can enhance the efficiency of the system and reduce energy costs. The operation of a Nano-grid can be classified into two categories: gradual, small, and slowly varying generation and loading conditions, and sudden and large variations. This study focuses on the first category, as the second category is managed by an Energy Management System (EMS) through load management.

IV. RESEARCH METHOD

This study uses a quantitative research method to answer the research questions. Experiments are conducted to compare the performance of AI algorithms, including deep neural network, random forest, and XGBoost, to the conventional instantaneous active and reactive power method for power quality improvement in modern power systems. The proposed Green Hydrogen Static Compensator device is also simulated and compared with DSTATCOM and ESTATCOM to demonstrate its efficiency and effectiveness in power factor correction, harmonic mitigation, and power balancing.



To answer the first research question, a mathematical model of the modified instantaneous active and reactive power method is created using MATLAB Simulink. A test nano-grid is also simulated with varying non-linear loads, inductive loads, and renewable generation to ensure a representative sample of approximately 5000 datasets is generated. The experiment is repeated under the same conditions to ensure repeatability and reliability of the experiment. The generated data is then used to train the AI algorithms. The performance of the AI algorithms compared to the instantaneous active and reactive power method is validated using data visualization and statistical methods.

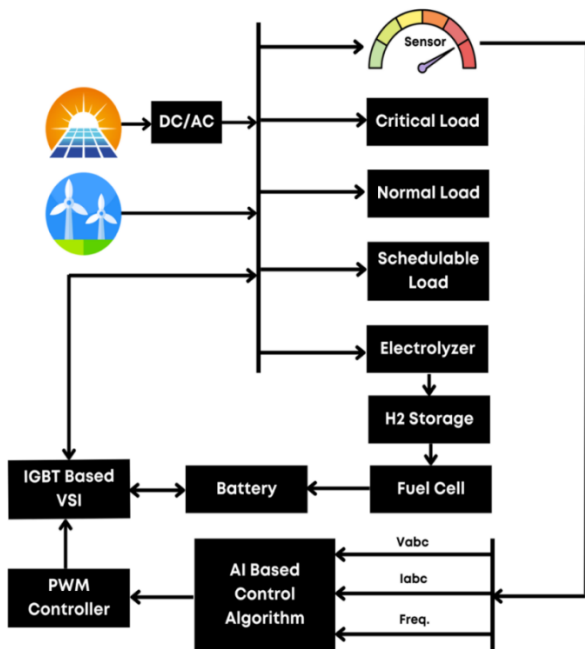

Fig. 1. Architecture of Nano-Grid with Proposed Control System

To answer the second research question, the advantages and limitations of the AI algorithms compared to the conventional methods for power quality improvement are also compared using the generated data. To answer the final research question, a mathematical model of the proposed GHSC device is created using MATLAB - Simulink and integrated with the trained AI model. The performance comparison of GHSC with DSTATCOM and ESTATCOM is done to demonstrate its efficiency and effectiveness in power factor correction, harmonic mitigation, and power balancing. The investigation is objective as mathematical methods and numerical data generated through simulations are used to draw conclusions.

A. Load Management of Nano-grid

In a nano-grid system, load management is a critical aspect that helps to ensure a reliable and sustainable power supply. The first step in load management is identifying the critical loads, which are essential for the basic functioning of the system during emergencies. This is done through a load analysis that determines the minimum amount of power required to keep these loads operational. The nano-grid is then designed to prioritize these loads, ensuring that they receive power during outages or grid failures. To optimize energy consumption, schedulable loads are utilized in the

nano-grid system. These loads, such as washing machines, electric vehicle chargers, and water heaters, can be turned on or off based on the availability of excess energy from renewable sources. This scheduling is automated and can be adjusted based on changes in energy supply and demand, providing flexibility in the management of the nano-grid system. In addition to critical and schedulable loads, normal loads, such as lighting, TVs, fans, air conditioners, and refrigerators, are also present in the nano-grid system. During emergencies or limited energy generation, these loads can be curtailed to conserve energy and ensure that critical loads continue to function. For example, air conditioners and refrigerators can be tripped for short durations to conserve energy while still maintaining a minimum temperature for customer comfort and safety. To further optimize load management, an energy management system (EMS) can be utilized. This system uses AI-based load and generation forecasting to schedule loads and manage energy consumption. However, this is outside the scope of this project.

B. Proposed Green Hydrogen Static Compensator

The proposed Green Hydrogen Static Compensator (GHSC) is designed to improve the performance of a nano-grid system. The GHSC comprises a battery energy storage mechanism that maintains the state of charge (SoC) between 40% and 60%, allowing energy absorption and supply as demanded by the control algorithm. The battery energy storage system includes a water electrolyser that produces green hydrogen when there is excess generation from the solar and wind electric generator, which is then stored in a storage tank. The stored green hydrogen is used by the fuel cell to replenish battery energy and maintain the SoC at the desired level. The control algorithm of the GHSC system is designed to dampen power oscillation that arises due to real power imbalance in the nano-grid system. It absorbs surplus power and supplies slack power to the nano-grid, ensuring that the power supply is stable and reliable. Additionally, the control algorithm senses the harmonic components instantaneously and injects them into the nano-grid out of phase, mitigating harmonic pollution. The GHSC system meets the entire reactive power requirement of the nano-grid, freeing the solar and wind electric generators from the reactive burden and maintaining unity power factor in the grid. An IGBT-based voltage source inverter is used to feed AC energy into the grid from the DC side (battery) and take back energy from the AC side (grid side) to the DC side (battery). The switching pulses for the IGBT-based voltage source inverter are generated by a Pulse Width Modulation (PWM) controller, which receives reference current from the control algorithm (AI/modified instantaneous active and reactive power). Sensors are used to provide feedback on three-phase voltage, current, and frequency to the control algorithm. Hence, the proposed GHSC system is an essential component of the Nano-grid system, helping to improve its reliability, stability, and performance.

AI Algorithm Based Green Hydrogen Static Compensator for Harmonic Mitigation, Power Balancing, and Power Factor Correction in Nano-Grids

By mitigating power oscillation, harmonic pollution, and reactive power burden, the GHSC system can optimize the performance of the Nano-grid, enabling it to provide reliable and sustainable power to its users.

V. MODIFIED INSTANTANEOUS ACTIVE AND REACTIVE POWER METHOD

The modified instantaneous active and reactive power method offers a comprehensive solution for enhancing the performance of nano-grids. This method serves three key purposes: power factor correction, harmonic mitigation, and power oscillation damping. To achieve power factor correction, the proposed GHSC instantly meets the entire reactive power demand of the load, thereby eliminating the need for reactive power management by renewable generators. This approach ensures that the system power factor remains at unity. The method also addresses harmonic distortion by estimating and injecting instantaneous harmonic components out of phase to eliminate harmonic components. This results in cleaner power, ensuring the efficient functioning of the nano-grid. Moreover, owing to the intermittency of renewable generators and constantly varying load, balancing the generation and load demand poses a challenge. Real power imbalance leads to power oscillation, which can be resolved by the proposed GHSC. The device locally supplies or absorbs real power to balance the system, thereby eliminating power oscillations. The block diagram of the modified instantaneous active and reactive power method is illustrated in Fig. 2. The three-phase current and voltage are first transformed into a two-phase stationary reference frame using (1) and (2). Instantaneous active and reactive power are then calculated using (3), assuming purely sinusoidal voltage and current.

$$\begin{pmatrix} i_\alpha \\ i_\beta \end{pmatrix} = \sqrt{\frac{2}{3}} \begin{pmatrix} 1 & -1/2 & -1/2 \\ 0 & \sqrt{3}/2 & -\sqrt{3}/2 \end{pmatrix} \begin{pmatrix} i_a \\ i_b \\ i_c \end{pmatrix} \quad (1)$$

$$\begin{pmatrix} v_\alpha \\ v_\beta \end{pmatrix} = \sqrt{\frac{2}{3}} \begin{pmatrix} 1 & -1/2 & -1/2 \\ 0 & \sqrt{3}/2 & -\sqrt{3}/2 \end{pmatrix} \begin{pmatrix} v_a \\ v_b \\ v_c \end{pmatrix} \quad (2)$$

$$\begin{pmatrix} p \\ q \end{pmatrix} = \begin{pmatrix} v_\alpha & v_\beta \\ -v_\beta & v_\alpha \end{pmatrix} \begin{pmatrix} i_\alpha \\ i_\beta \end{pmatrix} \quad (3)$$

However, if the voltage and current are non-sinusoidal, the harmonic components result in oscillating components in both active and reactive power, as shown in (4) and (5). To maintain unity power factor, the entire reactive power required to be compensated, including the dc and oscillating components, is determined using (6).

$$p = p_{dc} + p_{osc} \quad (4)$$

$$q = q_{dc} + q_{osc} \quad (5)$$

$$q = 1 \times q_{ref} \quad (6)$$

To separate the dc component of active power, a low pass filter (LPF) is employed, and the resulting oscillating component is subtracted from the total active power. This oscillating component corresponding to harmonics is then negated to ensure out-of-phase injection resulting in cancellation of harmonics. The frequency error, determined by comparing the sensed frequency with the reference frequency, is used by a PI controller to generate the reference for real power balancing, also known as power oscillation damping. This reference is added to the oscillating component of active power, as per (7), to obtain the net active power reference.

$$p_{ref} = p_{osc} + p_{balance} \quad (7)$$

$$\begin{pmatrix} i_\alpha^* \\ i_\beta^* \end{pmatrix} = \frac{1}{(v_\alpha^2 + v_\beta^2)} \begin{pmatrix} v_\alpha & v_\beta \\ v_\beta & -v_\alpha \end{pmatrix} \begin{pmatrix} p_{ref} \\ q_{ref} \end{pmatrix} \quad (8)$$

The current reference in the stationary reference frame is computed using (8) and then transformed to the abc reference using (9). The reference current is utilized by the pulse width modulation (PWM) controller to generate the switching pulses of the GHSC.

$$\begin{pmatrix} i_a^* \\ i_b^* \\ i_c^* \end{pmatrix} = \sqrt{\frac{2}{3}} \begin{pmatrix} 1 & 0 & 1 \\ -1/2 & \sqrt{3}/2 & 1 \\ 1/2 & \sqrt{3}/2 & 1 \end{pmatrix} \begin{pmatrix} i_\alpha^* \\ i_\beta^* \end{pmatrix} \quad (9)$$

Overall, the modified instantaneous active and reactive power method, as illustrated in Fig. 2, effectively addresses power factor correction, harmonic mitigation, and power oscillation damping in nano-grids. The modified instantaneous active and reactive power method, combined with the proposed GHSC, offers a reliable and effective solution for enhancing the performance of nano-grids.

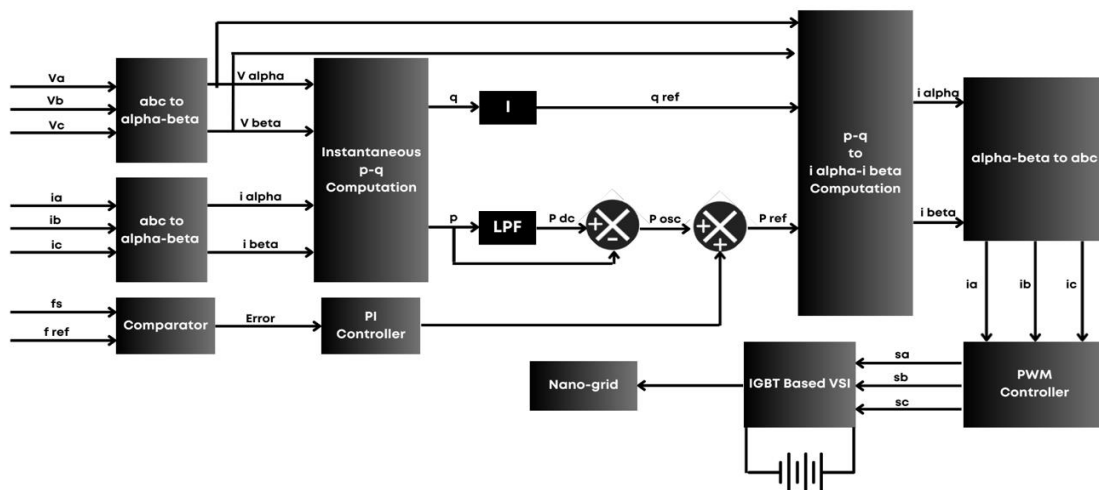

Fig. 2. Modified Instantaneous Active and Reactive Power Method

VI. ARTIFICIAL INTELLIGENCE BASED APPROACH

The increasing use of renewable energy sources and non-linear loads in power systems has led to a rise in harmonic pollution and power factor issues. Conventional methods for mitigating these issues, such as instantaneous p-q methods, have limitations in terms of accuracy and adaptability. Artificial intelligence (AI) algorithms, such as deep neural networks, random forest, and XGBoost, have emerged as promising alternatives for addressing these issues. These algorithms can learn from data and make accurate predictions, enabling them to effectively mitigate harmonic pollution and correct power factor in power systems. Additionally, AI algorithms have the potential to adapt to changing conditions and provide more accurate and efficient solutions compared to conventional methods.

A. Training Data

To train AI models for mitigating harmonic pollution, power oscillation and correcting power factor in a Nano-grid, training data is collected through simulation using MATLAB-Simulink Simscape Toolbox. The simulation is designed to replicate gradual, small, and slowly varying generation and loading conditions, as sudden and large variations are already addressed by the load management of the Energy Management System (EMS). By using a modified instantaneous active and reactive power algorithm during the simulation, the training data accurately captures the behaviour and performance of the Nano-grid under various conditions. The collected data is then used to train AI models, such as deep neural networks, random forest, and XGBoost, to effectively mitigate harmonic pollution, power oscillation and correct power factor in the Nano-grid. By utilizing simulation-based training data, the AI models are able to learn from realistic and diverse scenarios, enabling them to accurately predict and address issues in the actual Nano-grid system.

B. Transformer Architecture of Deep Neural Network

One recent development in deep learning neural network architecture that can produce output predictively in real-time without any delay is the Transformer architecture. Originally developed for natural language processing tasks, the Transformer architecture has been adapted for time-series data analysis and forecasting. The Transformer architecture utilizes a self-attention mechanism that allows it to learn dependencies between different elements in a sequence and

weigh them based on their relative importance. This enables the model to effectively capture long-term dependencies and patterns in time-series data. Furthermore, the Transformer architecture utilizes parallel processing, which allows it to process data in parallel across different time steps, reducing the computational time and enabling it to produce real-time predictions without any delay.

C. Random Forest

Random forest is a popular machine learning algorithm that has been used extensively for classification and regression tasks in various domains. In the context of mitigating harmonic pollution, power oscillation and correcting power factor in a Nano-grid, random forest has potential to produce promising results. One advantage of random forest is its ability to handle non-linear relationships and interactions between the input variables. This is particularly useful in the case of Nano-grids, where there may be complex relationships between the different variables that affect the power quality. Random forest is able to capture these relationships and interactions, enabling it to make accurate predictions and identify the most important features for power quality improvement. Another advantage of random forest is its ability to handle missing data and noisy features. In a real-world Nano-grid system, there may be missing data or noisy features due to sensor errors or other factors. Random forest is able to handle these issues by randomly selecting subsets of features and samples during training, which reduces the impact of noisy or missing data. Furthermore, random forest is able to provide an estimate of the importance of each feature in the prediction, which can be useful in identifying the most important factors affecting power quality and prioritizing corrective actions.

D. XGBoost

XGBoost also has the potential to produce good results in mitigating harmonic pollution, power oscillation and correcting power factor in a Nano-grid. Its ability to handle non-linear relationships, missing data, and noisy features, as well as provide feature importance estimates, makes it a valuable tool for improving power quality in a Nano-grid system. Another advantage of XGBoost is its ability to handle imbalanced datasets, where there may be a significant class imbalance in the training data. This is relevant in the context of Nano-grids, where power quality issues may be relatively rare compared to normal operating conditions. XGBoost is able to handle imbalanced datasets by adjusting the weights of the training samples, which improves the accuracy of the model predictions.

VII. SIMULATION RESULTS

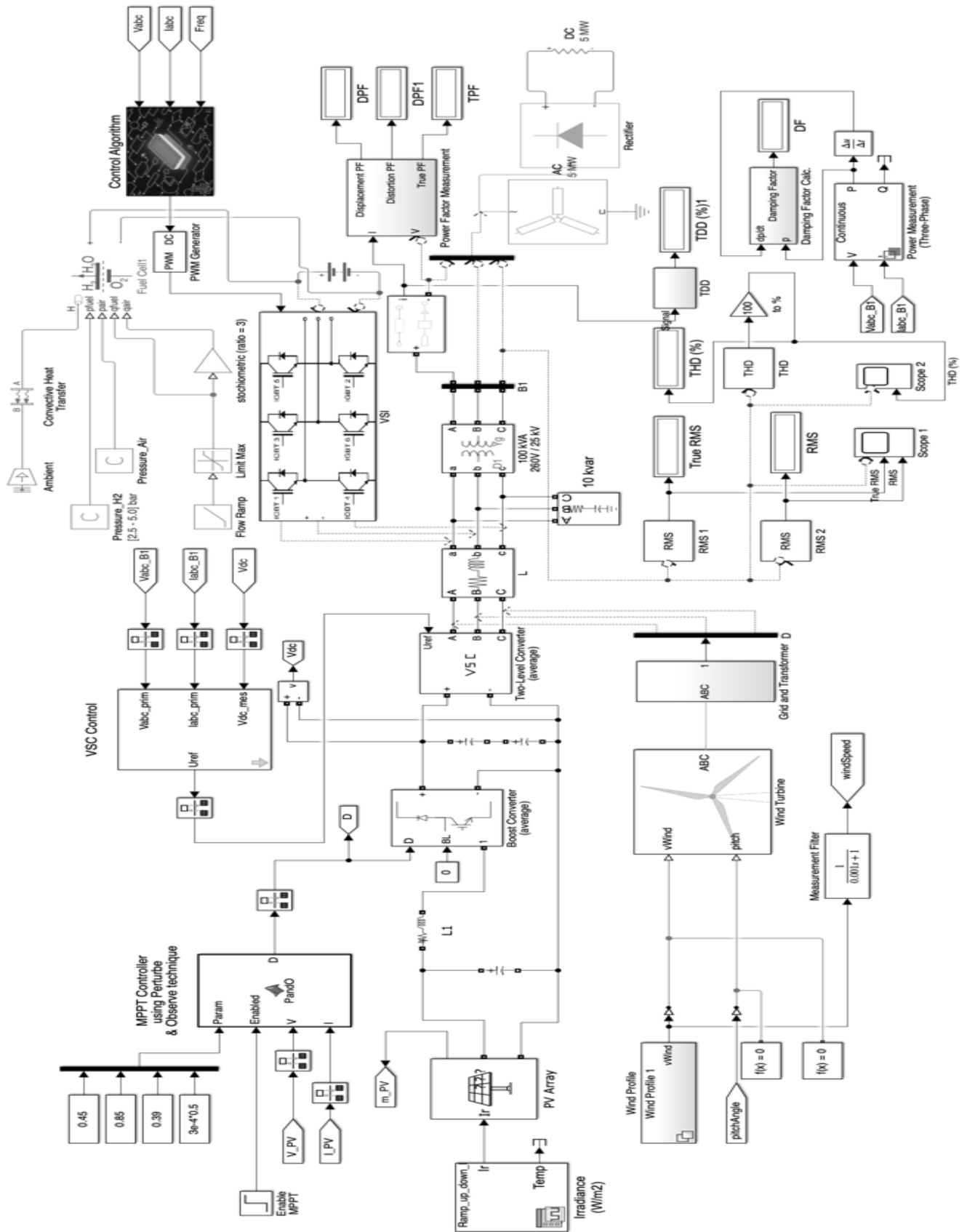

Fig. 3. MATLAB-Simulink Model of Nano-Grid with Proposed GHSC

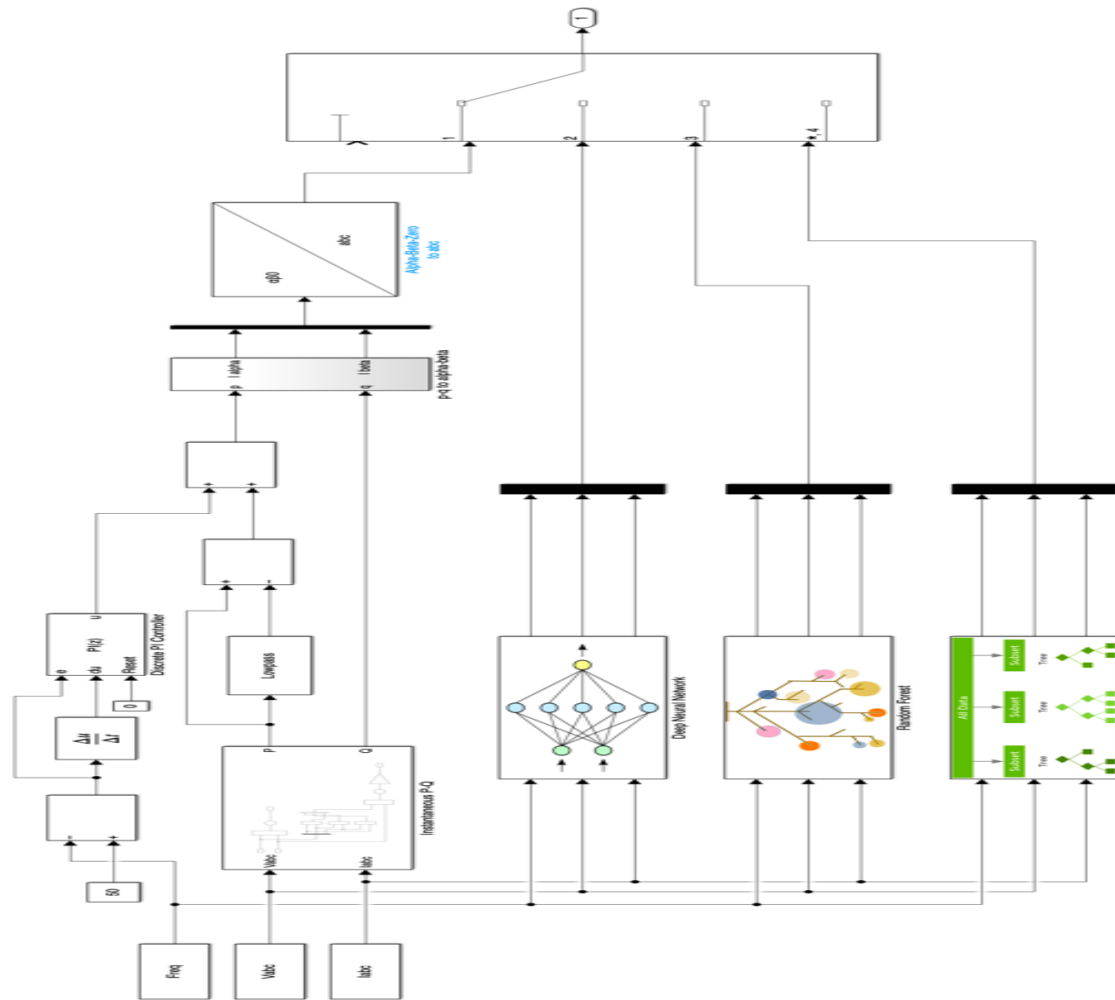

Fig. 4. MATLAB-Sim Scope Subblock of Control Algorithm

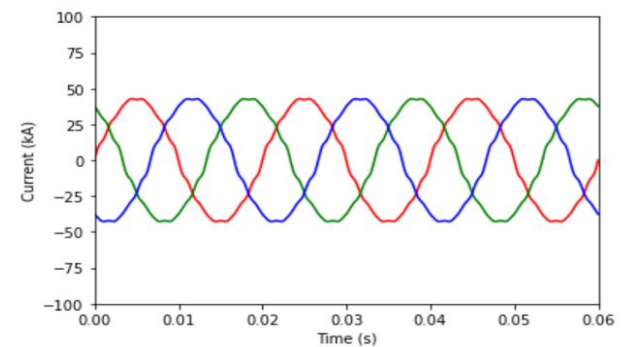
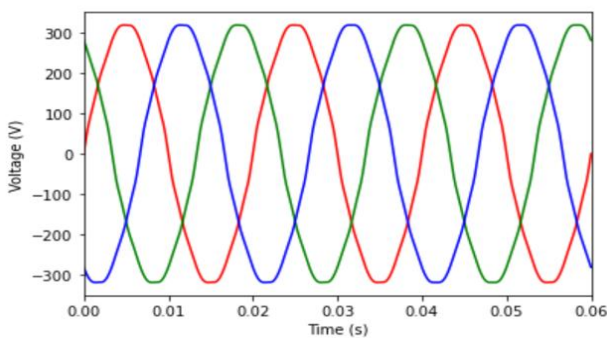
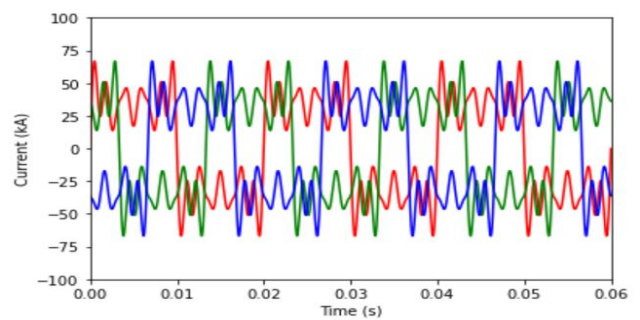
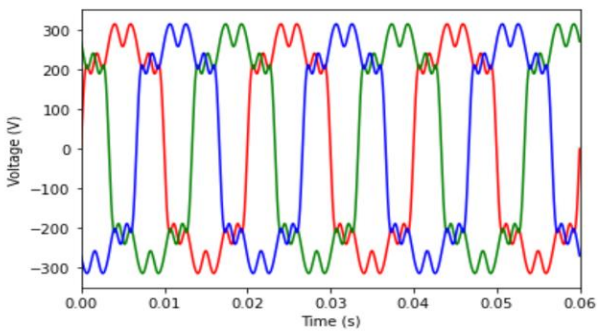

Fig. 5. Voltage Waveform without Compensator and with Compensator

Fig. 6. Current Waveform without Compensator and with Compensator

AI Algorithm Based Green Hydrogen Static Compensator for Harmonic Mitigation, Power Balancing, and Power Factor Correction in Nano-Grids

In this research paper, we aim to simulate Nano-grid architecture with both solar and wind electric generation, with proposed Green Hydrogen Static Compensator (GHSC) using MATLAB Simscape model shown in figure 3. The goal of this simulation study is to compare and evaluate the effectiveness and performance of different control algorithms in mitigating harmonic pollution, power oscillation, and power factor correction. By simulating different scenarios with varying levels of solar and wind electric generation, as well as different types of loads, AI algorithms are trained to adapt to changing conditions and effectively mitigate power quality issues. Specifically, imparting ability to maintain stable power output, correct power factor, and mitigate harmonic pollution. Finally we have tried four different control algorithms: the modified instantaneous active and reactive power method, deep neural network with transformer architecture, random forest, and XGBoost as shown in Fig. 4. The experiment is repeated by replacing GHSC with DSTATCOM and ESTATCOM and results are tabulated in table 1. Each of these algorithms has shown promise in addressing power quality issues in Nano-grid systems, and we aim to compare their performance in this simulation study. IEEE Standard 519-2014 sets the guidelines for harmonic control in electrical power systems. According to this standard, the THD for voltage typically must not exceed 5% for systems operating at voltages below 69 kV. For general systems with a maximum demand load more than or equal to the rating of 50% of the system's short circuit capacity at the PCC, the TDD should be less than or equal to 12%. M-PQ

and DNN produce results within the permissible limit. From simulation result tabulated in Table-I, we evaluated the performance of different devices, namely, DSTATCOM, ESTATCOM, and GHSC on several power quality metrics, including total harmonic distortion (THD) of voltage and total demand distortion (TDD) of current, damping factor (DF), and displacement power factor (DPF). We also compared the performance of different machine learning algorithms, including modified instantaneous active and reactive power algorithm (M-PQ), deep neural network-based Transformer architecture (DNN), random forest algorithm (RF), and XGBoost algorithm (XGB), on the same metrics. Our results indicate that the THD and TDD performance of all devices were comparable, with no significant differences observed. However, the DF of the DSTATCOM controller was found to be poor, as it only provides reactive power support, while ESTATCOM and GHSC were comparable, with GHSC being the best. This can be attributed to the constant state-of-charge (SoC) of the battery maintained by the Green Hydrogen supported fuel cell, which provides superior performance compared to the other devices. Additionally, the DPF of GHSC was found to be the highest among all the controllers. When comparing the different machine learning algorithms, our results indicate that the DNN algorithm provided the best performance. Therefore, we conclude that a DNN-based GHSC is more effective compared to the other controllers evaluated in this study and its effectiveness in harmonic mitigation of both voltage and current are depicted in Fig. 5 and Fig. 6 respectively.

Table-I: Performance Comparison

CA	DSTATCOM				ESTATCOM				GHSC			
	THD (%)	TDD (%)	DF (%)	DPF	THD (%)	TDD (%)	DF (%)	DPF	THD (%)	TDD (%)	DF (%)	DPF
M-PQ	5	12	15	0.92	5	12	44	0.92	5	12	46	0.95
DNN	4	10	18	0.94	4	9	42	0.95	4	9	47	0.96
RF	7	11	17	0.94	7	11	43	0.95	7	11	43	0.96
XGB	6	11	16	0.91	6	11	42	0.92	6	11	41	0.94

VIII. CONCLUSIONS

In conclusion, this research paper proposed a novel approach for addressing the challenges of integrating renewable energy sources in Nano-grids using a Green Hydrogen Static Compensator (GHSC). The paper presented a modified instantaneous p-q algorithm and utilized artificial intelligence (AI) algorithms, including deep neural networks, random forest, and XGBoost, to improve the accuracy and effectiveness of the GHSC in reducing harmonic pollution, correcting power factor, and balancing real power. The simulation study provided valuable insights into the performance of different control algorithms in addressing power quality issues in a Nano-grid system. The results indicate that the proposed mitigation device GHSC with transformer architecture based deep neural network approach outperforms the traditional method in terms of effectiveness, but limitations exist in terms of flexibility for real-time self-learning.

Based on the results of the study, future research directions include developing an automatic weight updating deep neural network based on real-time feedback of THD, power factor, and frequency. This would enable the GHSC to adapt to changing conditions in real-time, making it a more flexible and efficient solution for improving power quality in

a real-world Nano-grid system. The proposed AI algorithm based GHSC represents a significant contribution to the field of Nano-grid power quality improvement. It offers a sustainable and reliable solution for meeting increasing electricity demand while reducing the environmental impact of fossil fuels, and is expected to play a significant role in future energy distribution.

ACKNOWLEDGMENT

The authors would like to extend sincere appreciation to Effyies Smart Technologies LLP for their invaluable support throughout this research endeavor. The provision of their advanced laboratory facilities was instrumental in the successful execution and completion of this project. Their generosity and commitment significantly contributed to the quality and depth of our research. We are grateful for their unwavering support, which was integral to achieving the goals outlined in this study.

DECLARATION STATEMENT

The entirety of this project was executed by the first author under the supervision and guidance of the second author. No external funds or grants were received for this research. Both authors declare that there are no conflicts of interest to the best of our knowledge. This research-oriented article does not require ethical approval and consent to participate with evidence. The data for research is generated through simulation studies and hence data access statement is not relevant.

Funding	No, I did not receive any financial support for this article.
Conflicts of Interest	There is no conflicts of interest to the best of my knowledge.
Ethical Approval and Consent to Participate	The article does not require ethical approval and consent to participate.
Availability of Data and Material	Not relevant.
Authors Contributions	All authors have equal contributions for this article.

REFERENCES

- Akpolat, A. N., Habibi, M. R., Baghaee, H. R., Dursun, E., Kuzucuoğlu, A. E., Yang, Y., Dragicevic, T., & Blaabjerg, F., "Dynamic stabilization of DC microgrids using ANN-based model predictive control" in *IEEE Transactions on Energy Conversion*, vol. 37, no. 2, 2022, pp. 999–1010. <https://doi.org/10.1109/TEC.2021.3118664>
- Benavides-Córdoba, S., Ortiz-Castrillón, J. R., Gutiérrez-Villa, Y. A., Muñoz-Galeano, N., Cano-Quintero, J. B., & López-Lezama, J. M., "Assessment of energy quality indices for reactive power compensation with capacitor banks and D-STATCOM" in *Links Magazine*, vol. 18, no.1, 2021, pp. 232–241. <https://doi.org/10.14483/2322939X.15752>
- Dana Ragab, & Jasim Ghaeb. "Implementation of reactive compensator for voltage balancing using AI based models and novel performance index" in *International Journal of Power Electronics and Drive Systems (IJPEDS)*, vol. 1, no. 1, 2022, pp. 594-605. <https://doi.org/10.11591/ijpeds.v13.i1.pp594-605>
- De Oliveira, F. M., Mariano, A. C. S., Salvadori, F., & Ando Junior, O. H., "Power management and power quality system applied in a single-phase nanogrid" in *Energies* (19961073), vol. 15, no.19, 2022, pp. 7121. <https://doi.org/10.3390/en15197121>
- Dovgun V. P., D. E. Egorov, V. V. Novikov, A. F. Sinjagovsky, "Shunt power factor correction devices for damping of harmonic resonance in industrial power systems" in *Известия высших учебных заведений: Проблемы энергетики*, vol. 24, no. 4, 2022, pp. 77-89. <https://doi.org/10.30724/1998-9903-2022-24-4-77-89>
- Eko Adhi Setiawan, & Novagia Adita. "Hybrid nanogrids development to improve residential reliability and resiliency supply: Testing and implementation" in *Energy Reports*, vol. 8, 2022, pp. 284–290. <https://doi.org/10.1016/j.egvr.2022.01.060>
- Frifita, K., Boussak, M., "A novel strategy for high performance fault tolerant control of shunt active power filter" in *Electrical Engineering*, vol.104, 2022, pp. 2531–2541. <https://doi.org/10.1007/s00202-022-01504-9>
- Giuseppe Barone, Giovanni Brusco, Daniele Menniti, Anna Pinnarelli, Nicola Sorrentino, Pasquale Vizza, Alessandro Burgio, Ángel A., Bayod-Rújula. "A renewable energy community of DC nanogrids for providing balancing services" in *Energies*, vol. 14, 2021, pp. 7261. <https://doi.org/10.3390/en14217261>
- Meliani, M., Barkany, A. E., Abbassi, I. E., Darcherif, A. M., Mahmoudi, M., "Energy management in the smart grid: State-of-the-art and future trends" in *International Journal of Engineering Business Management*, vol. 3, 2021, pp. 1–26. <https://doi.org/10.1177/18479790211032920>
- Naaz, N., Channegowda, J., "XGBoost Based Synthetic Battery Parameter Generation to Overcome Limited Battery Dataset Challenges" in *IEEE International Conference on Power Electronics, Smart Grid, and Renewable Energy-2022 (PESGRE)*, 2022, pp. 1–4. <https://doi.org/10.1109/PESGRE52268.2022.9715814>
- Prakash, T., Senthil Kumar, V., "Improvement of oscillatory stability in wide area controlled systems using power injection" in *Wireless Personal Communications*, vol. 117, no. 4, 2021, pp. 3193–3207. <https://doi.org/10.1007/s11277-020-07800-6>
- Rohani, A., Joorabian, M., Abasi, M., Zand, M., "Three-phase amplitude adaptive notch filter control design of DSTATCOM under unbalanced/distorted utility voltage conditions" in *Journal of Intelligent & Fuzzy Systems*, vol. 37, no. 1, 2019, pp. 847–865. <https://doi.org/10.3233/JIFS-181521>
- Sunil Kumar, C., Puttamadappa, C., & Chandrashekar, Y. L., "Power quality improvement in grid integrated PV systems with SOA optimized active and reactive power control" in *Journal of Electrical Engineering & Technology*, vol.5, 2022, pp. 1–16.
- Irfan, M. M., Chandrashekar, Dr. P., & Sushama, Dr. M. (2019). Power Management Policies in Distributed Generation and Potential Opportunities for Future Research. In *International Journal of Innovative Technology and Exploring Engineering* (Vol. 9, Issue 2, pp. 143–148). Blue Eyes Intelligence Engineering and Sciences Engineering and Sciences Publication - BEIESP. <https://doi.org/10.35940/ijitee.a5260.129219>
- Dash, S., & Santra, R. (2020). Internet of Things Enabled Smart Microgrid. In *International Journal of Engineering and Advanced Technology* (Vol. 9, Issue 6, pp. 73–76). Blue Eyes Intelligence Engineering and Sciences Engineering and Sciences Publication - BEIESP. <https://doi.org/10.35940/ijeat.f2186.089620>
- Smart Assimilation of Renewable Based Microgrids. (2019). In *International Journal of Recent Technology and Engineering* (Vol. 8, Issue 2S8, pp. 1617–1622). Blue Eyes Intelligence Engineering and Sciences Engineering and Sciences Publication - BEIESP. <https://doi.org/10.35940/ijrte.b1116.0882s819>
- Rajasekaran, G., & Ram, Dr. C. S. (2023). Breast Cancer Prediction Based on Feature Extraction using Hybrid Methodologies. In *International Journal of Soft Computing and Engineering* (Vol. 13, Issue 2, pp. 20–28). Blue Eyes Intelligence Engineering and Sciences Engineering and Sciences Publication - BEIESP. <https://doi.org/10.35940/ijscce.b3612.0513223>
- Gupta, S. K. (2022). Smart Grid System in India. In *Indian Journal of Energy and Energy Resources* (Vol. 1, Issue 4, pp. 5–6). Lattice Science Publication (LSP). <https://doi.org/10.54105/ijeer.c1018.081422>

AUTHORS PROFILE



Dr. T. Ruban Deva Prakash, a distinguished educator, and principal with over 25 years of experience, currently pursuing post-doctoral research at Eudoxia Research University, USA. He has received 4 national and 1 international award for educational excellence, served as a principal at Government College of Engineering, Munnar, and possesses 30 certifications. Dr. Prakash is a prolific researcher with 100+ papers, 2 books, and 2 patents, doubling as a technical consultant for industries and startups in the power sector. As a director of Effyies Smart Technologies and Achshah Fashion, he mentors scholars and supervises research in multiple universities, epitomizing a commitment to education, innovation, and impactful industry engagement.



Achshah R M, CEO of Effyies Smart Technologies LLP, is currently pursuing a post-doctorate degree at Eudoxia Research University in the United States. Renowned as a leading data scientist and researcher, Achshah demonstrates a fervent commitment to narrowing the divide between academia and industry. With an impressive scholarly contribution, Achshah has authored 11 journal articles, published 2 books, and holds 2 patents in the realm of artificial intelligence (AI). This comprehensive expertise underscores Achshah's dedication to pioneering advancements at the intersection of academia and practical AI applications.

Disclaimer/Publisher's Note: The statements, opinions and data contained in all publications are solely those of the individual author(s) and contributor(s) and not of the Blue Eyes Intelligence Engineering and Sciences Publication (BEIESP)/ journal and/or the editor(s). The Blue Eyes Intelligence Engineering and Sciences Publication (BEIESP) and/or the editor(s) disclaim responsibility for any injury to people or property resulting from any ideas, methods, instructions or products referred to in the content.

