

**Problem Booklet
2022/23**

Czech Astronomy Olympiad



**Board of Organizers of
the Czech Astronomy
Olympiad**

Prague, 2023

Czech Astronomy Olympiad

Problem Booklet 2022/23

Board of Organizers
of the Czech Astronomy Olympiad



Our partners



planetum



Seyfor

ICZ

Edited by Jakub Vošmera, David Kománek, Václav Pavlík and Tomáš Gráf

Cover design by Tomáš Gráf and Václav Pavlík

Cover image: Unisphere, Institute of Physics, Opava

Problems translated into English by David Kománek, Jakub Vošmera, Radka Křížová,
Radomír Mielec

Published by the Czech Astronomical Society, Fričova 298, 251 65 Ondřejov, Czechia

First edition in Prague, 2023

Typset in L^AT_EX

This publication is not for sale.

Copyright © Czech Astronomy Olympiad, 2023

<http://olympiada.astro.cz>

ISBN: 978-80-907341-5-9

DOI: 10.5281/zenodo.10214525

Contents

Introduction	4
Theoretical Problems	5
Geometry, time and instrumentation	5
Solar system	9
Stellar astronomy	24
Binary stars and exoplanets	27
Cosmology and relativity	32
Practical Problems	35

Introduction

Czech Astronomy Olympiad is divided into four age categories AB, CD, EF and GH (from the oldest to the youngest). Each category is organized in three rounds. The first round takes place at school with its main objective to attract pupils to astronomy and motivate them for further work. In the second (regional) round, participants are asked to solve more complex problems, as well as to perform simple observations. The best participants proceed to the national rounds held in Opava and Prague in March and May.

Each problem presented in this booklet comes with its name and ID code containing information about the place of its original use in the Olympiad. For instance, “CD/R/2” denotes the second problem in the regional round of the CD category. Most problems have their answers shown in small print.

Majority of the competition problems are original work of the Czech AO organizers. Problem CD/N/7 was adapted from The ESA/ESO Exercise Series booklets, problem AB/N/7 was adapted from IAO 2003. Credits for the rest of the problems presented in this volume:

Jindřich Jelínek: CD/R/2, AB/N/5, CD/N/8; *David Kománek*: CD/N/5, AB/N/2, CD/N/7, AB/R/3; *Radka Křížová*: EF/R/1, EF/N/1, EF/R/3; *Pavel Kůs*: CD/N/1, CD/N/6, AB/R/2, CD/N/3, CD/N/4, AB/N/4; *Jiří Kohl*: CD/R/1, AB/N/7; *Radomír Mielec*: EF/N/2, AB/N/8; *Marco Souza de Joode*: CD/N/2, AB/N/1, AB/R/3; *Lukáš Supík*: AB/R/1, AB/N/3; *Jakub Vošmera*: AB/N/6, EF/R/2

The reader certainly would not be able to enjoy the problems in their present form were it not for the careful reviews of *Petr Kulháněk*, *David Břeň*, *Ota Kéhar* and *Michal Švanda*.

Finally, we want to express our gratitude to the director of the Prague Observatory and Planetarium, *Jakub Rozehnal*, and the vice-dean of Faculty of Philosophy and Science of Silesian University in Opava, *Tomáš Gráf*, for kindly providing the venue for the national rounds. We also thank *Tomáš Prosecký* and *Lenka Soumarová* for helping to make the Czech Astronomy Olympiad happen by providing administrative support.

Theoretical problems

Geometry, time and instrumentation

Watching the game

CD/R/2

Consider an observatory which is equipped with a telescope with diameter $D \simeq 30$ cm and focal length $f \simeq 2.5$ m. On a cloudy night, local astronomers decided to point the telescope at a nearby residential area located at distance $s \simeq 1$ km and watch a game of football on a TV through a window. They were using an eyepiece with focal length $f' \simeq 10$ mm.

- Find the angular magnification of the telescope. Assuming that the TV screen has diagonal length $u \simeq 80$ cm, find the angular size of the screen when it is viewed through the telescope. At what distance from the television would a person have to stand to see it with the same angular size with a naked eye?
- As the telescope is set up for night-sky observations, it is focused at infinity. Determine by how many millimetres do the astronomers have to move the eyepiece in order to refocus on the television.
- Since the astronomers think that the magnification is too small, they decide to put a Barlow lens between the objective and the eyepiece. A Barlow lens is a concave (diverging) lens, or a set of lenses that behave like a concave lens. This particular Barlow lens has focal length $f_B \simeq 20$ mm and it was placed before the eyepiece at a distance $a \simeq 30$ mm from it. The lens is firmly attached to the eyepiece, so that the two are moving together. Find the distance by which the astronomers have to move the eyepiece and Barlow lens in order to get the image back into focus.
- By what factor did the magnification increase compared to the original state without the Barlow lens?

[a) $250, 11^\circ, 4$ m; b) 6.3 mm; c) 10 mm; d) 2]

Stellar interferometry**CD/N/1**

Stellar interferometry is a technique used to produce high-resolution images of stars by combining signals from two or more telescopes. Angular resolution of the image is then determined based on the distance between the telescopes and the wavelength of the observed light.

A star has an estimated diameter of 1.5 million kilometres and is located at a distance of 10 parsecs from Earth. The star is observed by two telescopes at a wavelength of 500 nm. The distance between the telescopes is 100 metres.

- Find the angular diameter θ_{star} of the star as seen from Earth.
- Find the angular resolution θ_{res} of the interferometer at this wavelength.
- Will the interferometer be able to resolve the disk of the star (YES/NO)?
- Assume that an upgrade took place which enabled the interferometer to work at a shorter wavelength of 250 nm. Determine the new angular resolution θ'_{res} and decide whether the disk of the star can be resolved at this wavelength (YES/NO).

[a) 4.86×10^{-9} rad; b) 6.1×10^{-9} rad; c) NO; d) 3×10^{-9} rad, YES]

 $\pi = 3$ **CD/N/2**

A polar bear living at the North Pole has learned that the ratio between the circumference of a circle and its diameter is always $\pi = 3.1415926535\dots$. So he decided he had to check this fact for himself.

The bear set off from the North Pole along a meridian towards the south, and walked a distance ϱ , as measured along the surface of the Earth, to a point A with latitude $\phi = \pi/2 - \theta$. At this point he made a right-angle turn and walked along a parallel until he came back to the point A. In doing so, he circumnavigated a circle of circumference ω . He expected to get

$$\omega = 2\pi\varrho,$$

but instead he got

$$\omega = 2\Pi_{\theta}\varrho,$$

where Π_{θ} plays the role of π . However, unlike π , it is not a constant but a function depending on the angle θ . Note that the north pole corresponds to $\theta = 0$ and the south pole corresponds to $\theta = \pi$ radians.

- Find the function Π_{θ} and evaluate it for $\theta = \{\frac{\pi}{6}, \frac{\pi}{2}, \frac{5\pi}{6}\}$. For what θ do we have $\Pi_{\theta} = 3$?
 - Evaluate Π_{θ} when $\theta = \pi$ and when $\theta \rightarrow 0$ but $\theta \neq 0$. Explain your results.
- [a) $\Pi_{\theta} = \pi \frac{\sin \theta}{\theta}$, for $\theta = \{\frac{\pi}{6}, \frac{\pi}{2}, \frac{5\pi}{6}\}$ we have $\Pi_{\theta} = \{3, 2, \frac{3}{5}\}$, $\Pi_{\theta} = 3$ for $\theta = \pi/6$; b) 0, π]

Topocentric

CD/N/5

It is midnight on the day of the vernal equinox. Observer 1 is positioned on the equator and is privileged to see a perfect conjunction of Mars and Jupiter exactly on the eastern horizon (the centers of their disks coincide).

- Calculate the distance $d_{M,1}$ of Mars and $d_{J,1}$ of Jupiter from Observer 1. Assume that the orbits of all planets around the Sun are circles and that they are confined to the plane of the ecliptic.
- What are the corresponding distances which would have been measured by Observer 2 who saw the conjunction at the exact same moment as Observer 1 but was located at a place where Jupiter was at zenith? In particular, find the differences $d_{M,1} - d_{M,2}$ and $d_{J,1} - d_{J,2}$. Watch out for rounding errors.
- Find the angular distance Δ between the centers of the disks of the two planets as seen by Observer 2. Will the disks overlap? Answer YES/NO and justify your answer.
- Find the azimuth A_1 (measured from the south) at which can Observer 1 see the conjunction. Find the latitude φ_2 of Observer 2.

Hint: for the sides a, b, c and the corresponding angles α, β, γ of a spherical triangle, the laws of sines and cosines hold in the form

$$\frac{\sin a}{\sin \alpha} = \frac{\sin b}{\sin \beta} = \frac{\sin c}{\sin \gamma},$$

$$\cos c = \cos a \cos b + \sin a \sin b \cos \gamma \quad (\text{and cyclic reorderings}).$$

Observer 2 decided to take a photo of the event using a telescope on an altazimuthal mount. However, unlike an equatorial mount, this mount does not guarantee that the field will not be rotated during a long exposure while pointed towards an object.

- Calculate the angle ω by which the field in the telescope rotates if the observer starts taking pictures an hour after Jupiter was at zenith. Assume that the exposure time was $\tau \simeq 5$ min.

Hint: field rotation is associated with a change of the parallactic angle q , which can be found at one of the vertices of the nautical triangle which is displayed Figure 1.

[$d_{M,1} \simeq 1.7 \times 10^{11}$ m, $d_{J,1} \simeq 7.6 \times 10^{11}$ m; b) $d_{M,1} - d_{M,2} \simeq 6\,377\,900$ m, $d_{J,1} - d_{J,2} \simeq 6\,378\,000$ m; c) $6.0''$, YES; d) $19^{\text{h}}\,34^{\text{m}}$, -23.5° ; e) $-15'$]

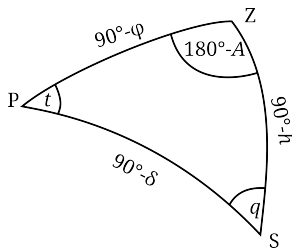

Figure 1: Nautical triangle: t denotes the hour angle, A azimuth, φ latitude, δ declination, h altitude above the horizon and q parallactic angle. P marks the north celestial pole, Z the zenith and S an object in the sky.

Nightmare of Gregory XIII.

AB/N/1

The precession period of the Earth's rotational axis is $P \simeq 25\,725$ years and is referred to as the Platonic year. It causes the first point of Aries to travel along the ecliptic so that in ancient Greece, it could be found in Aries while nowadays it is located in Pisces. In addition, the Earth's orbit around the Sun precesses with a period of approximately $\Pi \simeq 112\,000$ years. This precession is said to be positive, which means that it takes place in the direction of the Earth's orbit around the Sun. In the present epoch, the Earth passes through its perihelion on January 3 and vernal equinox occurs on March 20 or 21. The tropical year lasts $Y_T \simeq 365.242\,19$ days. The Gregorian calendar uses the following rules:

1. A non-leap year has 365 days.
 2. If a year is divisible by four, then it is a leap year (it has 366 days).
 3. If the year is divisible by 100, then it is *not* a leap year.
 4. But if it is divisible by 400, then it *is* a leap year.
- a) Determine the mean length of the Gregorian year Y_G (numerically in days). Determine the time it takes for the Gregorian calendar to drift relative to the seasons by one day.
 - b) Decide whether the point on the ecliptic where the Sun can be found at the moment of Earth's perihelion moves along the ecliptic in the same or in the opposite direction as the first point of Aries. Justify your statement. Determine how often these two points coincide (numerically in years). Determine as precisely as possible the date and the year of the closest such coincidence in the future.

[a) 365.2425 d, 3225 years; b) opposite direction, 20919 years, March 18-20, 6376 AD]

OPAVA-1**AB/N/2**

Due to continued bad weather, the regional round contestants decided to launch a space telescope into Earth's orbit. The OPAVA-1 mission has primary mirror with a diameter of $D \simeq 20$ cm and a sensitive CCD camera that needs only $N \simeq 100$ photons to register a signal. Calculate the upper limit m_{lim} (in mag) on the magnitude of the stars that one can distinguish on images with exposure time $\tau \simeq 30$ s. For simplicity, you should assume that a star can, in principle, be imaged using only one pixel of the sensor, and that stars radiate all of their power on the wavelength $\lambda \simeq 500$ nm. Neglect atmospheric extinction and all noise sources.

[22.0 mag]

Solar system**Positional astronomy****EF/R/1**

Astronomers like to define a number of prominent positions of objects (planets) relative to the Sun and the Earth.

- Assign the following prominent positions to the numbers 1 to 5 in Figure 2: opposition, superior conjunction, inferior conjunction, elongation, quadrature. The letters S and E in the figure indicate the Sun and the Earth.
- Can an outer planet, such as Jupiter, ever be in conjunction (either superior or inferior) with the Sun when observed from the Earth?
- Can an inner planet, such as Venus, be in opposition with the Sun when observed from the Earth?

To characterize an orbit of a planet around the Sun, we will use a quantity called angular speed (denoted by ω). It expresses the angular distance which an object travels in its orbit per a fixed amount of time. In particular, over the course of one orbital period T , the object completes one full orbit, that is, it travels angular distance 360° . The angular speed can therefore be calculated as $\omega = \frac{360^\circ}{T}$. Throughout this problem, we will assume that both the Earth and Mars orbit the Sun in circular orbits with constant angular speed.

When observing Mars from the Earth, a period of $T_{\text{syn}} \simeq 780$ d passes between two consecutive oppositions. This is referred to as the synodic orbital period. The corresponding synodic angular speed is simply the relative angular speed of the two planets as they orbit the Sun, namely

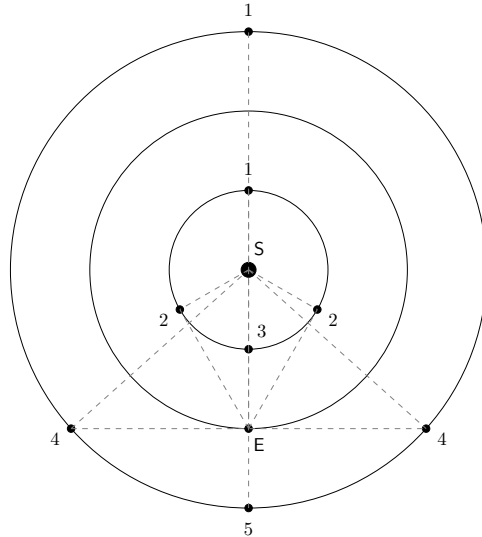

Figure 2: Prominent positions relative to the Sun and the Earth.

- d) Given the value of the synodic orbital period of Mars, find its sidereal orbital period $T_{M,\text{sid}}$ (in days, rounded to the nearest integer).
 e) Based on the result you found in part d), use the 3rd Kepler's law to determine the semi-major axis a_M (which, for a circular orbit, is the same as the radius) of the orbit of Mars around the Sun (in astronomical units).

[b) YES; c) NO; d) 687 d; e) 1.52 au]

Transit of Venus

EF/N/1

Two astronomers, a penguin and a capybara, want to measure the distance between the Earth and the Sun. As they are both very smart, they thought of an ingenious way of measuring this distance using an observation of Venus as it transits across the solar disk. At the core of their method stands the principle of parallax: this is an angular displacement in object's apparent position relative to the background which occurs when the object is viewed from two different locations. In the case at hand, the role of the object will be played by the planet Venus, which will be observed from two different locations on Earth against the background of the solar disk. The penguin will be stationed at the Tropic of Cancer while the capybara will set up her observation post near the Tropic of Capricorn.

Before they set on their endeavour to observe the transit, they have to collect some important pieces of information. First, based on long-term observations, they find the synodic orbital period of Venus to be $T_{\text{syn}} \simeq 583.92$ d. As you may remember from the regional round, this is the time which it takes for Venus to return back to the same position relative to the Earth and the Sun, such as the interval between two consecutive inferior conjunctions. In addition, they of course know the sidereal orbital period of the Earth around the Sun, namely $T_{\text{E,sid}} \simeq 365.25$ d.

- a) Draw a picture of the penguin or the capybara while observing the transit of Venus.
- b) Given the above data, calculate the sidereal orbital period of Venus around the Sun $T_{\text{V,sid}}$.

The two animals would like to use this result to determine the ratio of the semi-major axes for the orbits of Venus and Earth. Fortunately, they can recall the 3rd Kepler's law.

- c) Find the ratio p of the semi-major axes of Venus and Earth, that is $p = a_{\text{V}}/a_{\text{E}}$.

The rest of the input which is required for determining the Sun-Earth distance was obtained based on the Venus transit observations which were carried out by the two animals. Let us denote the angular radius of the solar disk by ρ . As the penguin and the capybara were observing the transit from two distinct locations on the Earth's surface, they experienced it somewhat differently. In particular, to compare their observations, they plotted their recorded paths of Venus across the solar disk in a single diagram that looked rather like the one which is shown in Figure 3 (beware, it is not to scale!). The red line marks the path of Venus as seen by the penguin, while the blue line corresponds to the path observed by the capybara. Unfortunately, after they plotted the observed trajectories, they found that the two lines are so close to one another that measuring their angular distance Δx based on the plot would be very difficult and would yield inaccurate results. In other words, the parallax Δx of Venus against the background the solar disk turned out to be very small.

To their relief, they have eventually managed to come up with a more accurate way of determining Δx . Quite fortunately, they both remembered to note down the exact times of the moments (the so-called *contacts*) when the disk of Venus entered and left the solar disk. In general, during a transit event, four contacts of the transiting object with the disk of the background object can be distinguished. In the case of the Venus transit, these are the following (see also Figure 4):

1st contact: while the disk of Venus is still completely outside of the solar

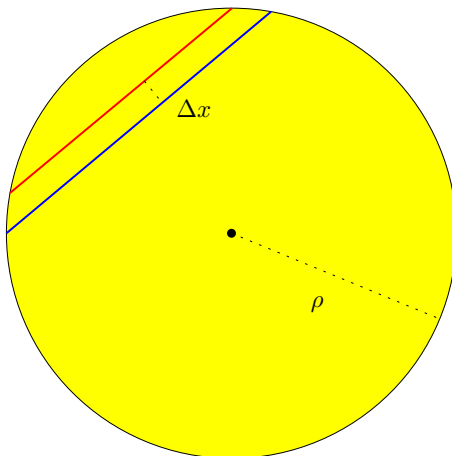

Figure 3: The path of Venus projected onto the solar disk as seen by two different observers on the Earth’s surface (the red line belongs to the penguin, the blue to the capybara).

disk, the limbs have just touched and Venus is moving inside.

2nd contact: the disk of Venus is now completely inside the solar disk, but the limbs are still touching.

3rd contact: Venus is still completely inside but having completed most of the transit, the limbs got into touch again on the other side.

4th contact: the disk of Venus has just completely cleared the solar disk.

In Table 1, you can find the times of these contacts as recorded by each astronomer.

Table 1: Times of individual contacts of the disk of Venus with the solar disk as observed by the penguin and the capybara (in the HH:MM:SS format). t_1 denotes the first contact, t_2 denotes the second contact etc.

Observer	t_1	t_2	t_3	t_4
penguin	10:31:48	10:54:13	15:53:55	16:16:20
capybara	10:27:21	10:49:46	15:58:22	16:20:47

- d) Calculate the duration T_p and T_c (in seconds) of the transit of Venus across the solar disk as measured by the penguin and by the capybara, respectively. Consider the duration of the transit to be defined as the

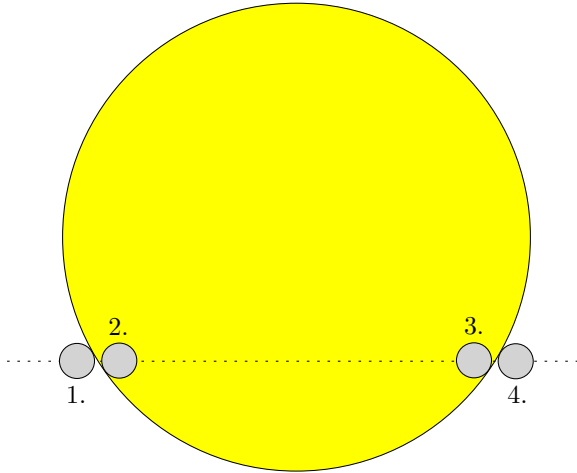

Figure 4: Contacts of the disk of Venus (grey) with the solar disk.

time which has elapsed between the two contacts of the *center* of the disk of Venus with the limbs of the Sun.

- e) Both animals also measured the angular speed of Venus relative to the Sun. They both came up with a value of approximately $\omega \simeq 1.59^\circ \text{d}^{-1}$. Calculate the angular lengths l_p and l_c of the path of Venus across the solar disk as seen by the penguin and the capybara (in arcmin), respectively.

To determine distances between the objects involved in this celestial alignment, it is instrumental to find the angular separation Δx of the two recorded paths of Venus on the solar disk, i.e. the parallax of Venus against the background of the solar disk. Before embarking on this calculation, you may find it helpful to refer to Figure 5, where x denotes the perpendicular (angular) distance of the path of Venus from the center of the solar disk. Assume that the angular radius ρ of the Sun is equal to $16'$.

- f) Determine the value of Δx in arcmin.

At this point, we must turn the parallax Δx into a concrete result for the linear distance of Venus from Earth. Here we have to be cautious as the parallax Δx was read off relative to a background which was not infinitely far from the observer. In particular, we should use the general relation

$$\frac{L}{D} = \frac{d_{\text{obs}}}{d_{\text{obj}}} \alpha,$$

where α is the parallax in radians, L is the separation of the two observation

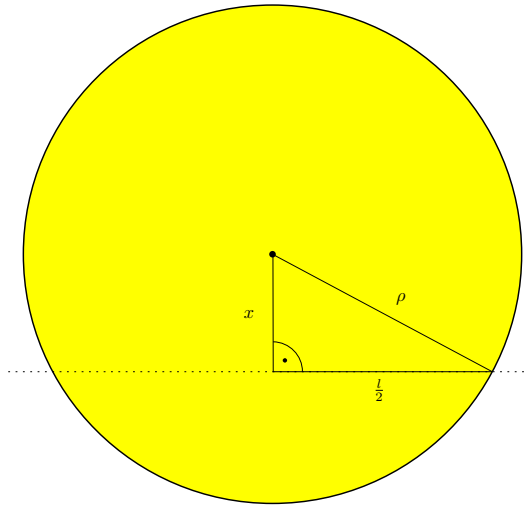

Figure 5: Geometry of the transit of Venus across the solar disk.

posts measured along a line perpendicular to the Earth–object axis (a.k.a. the base of the parallax), D is the distance of the object from the two observers and finally, d_{obj} and $d_{\text{obs}} = D + d_{\text{obj}}$ are the distances of the object and the observers from the background on which the parallax is projected. See also Figure 6. We assume that the angle α is very small. We can see that in the limit of infinite distance of the background from the observers and the object, we can approximately write $d_{\text{obs}}/d_{\text{obj}} \approx 1$ so that we recover the usual relation for the parallax.

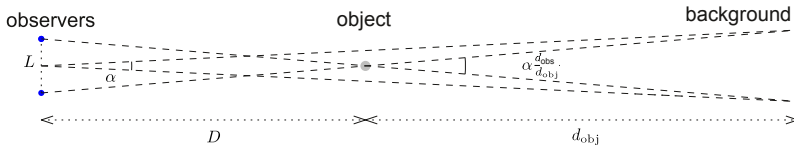

Figure 6: Parallax of an object on a finitely distant background.

- g) Using the result of part c), determine the distance $D = a_E - a_V$, as well as the distance a_E between the Sun and the Earth. You may assume

that the perpendicular separation L of the penguin and the capybara can be calculated as $L = R_E \sin 2\varepsilon \simeq 4665$ km, where $\varepsilon \simeq 23.5^\circ$ denotes the inclination of the Earth's axis of rotation with respect to the plane of the ecliptic.¹

[b) 225 d; c) 0.72; d) $T_p \simeq 19327$ s, $T_c \simeq 19861$ s; e) $l_p \simeq 21.34'$, $l_c \simeq 21.93'$; f) 0.27'; g) $D \simeq 42.8 \times 10^9$ m, $a_E \simeq 153 \times 10^9$ m]

Escape from the Solar System

CD/R/1

If a spacecraft is to be sent to the outer planets of our Solar System or beyond, it needs to be accelerated to a relatively high speed. As it is very expensive to accelerate the spacecraft to such a speed using only fuel, gravitational effects of other planets are commonly used to provide additional boost. To this end, before the spacecraft reaches its intended destination, it can be guided to pass close to other planets to perform a *gravitational slingshot* maneuver. This has the effect of providing the spacecraft with a greater heliocentric speed than it had before the flyby.

Consider a spacecraft which leaves the Earth's sphere of gravitational influence at a speed v_0 (relative to the Sun) in the direction of the Earth's orbital motion. The spacecraft then approaches Mars with heliocentric speed v_1 and its orbit intersects the orbit of Mars at an angle α , see Figure 7.

In the following questions, you should assume that both the Earth and Mars orbit the Sun along circular trajectories with radii a_E and a_M , respectively. While, at a generic location within the Solar System, it is the gravitational field of the Sun that has the dominant effect on the motion of the spacecraft, you can assume that when the spacecraft passes close to Mars, the gravitational field of the planet dominates.

In order to make your expressions more transparent, you will find it convenient to introduce the dimensionless parameters

$$\chi = \frac{a_E}{a_M}, \quad \eta = \left(\frac{u_E}{v_0} \right)^2,$$

where $u_E = \sqrt{2GM_\odot/a_E}$. Numerically, χ is equal to the radius of the Earth's orbit in multiples of the radius of the orbit of Mars, while η is equal to the ratio of squares of the escape velocity from the distance a_E from the Sun and the speed v_0 of the probe when it leaves the Earth.

a) Find v_1 , as well as $\cos \alpha$, in terms of v_0 and the parameters χ and η .

¹Here we take advantage of the fact that the shortest line connecting the planes of the tropic of Cancer and Capricorn is parallel to the Earth's axis of rotation and therefore always makes an angle of $90^\circ - \varepsilon$ with the plane of the ecliptic.

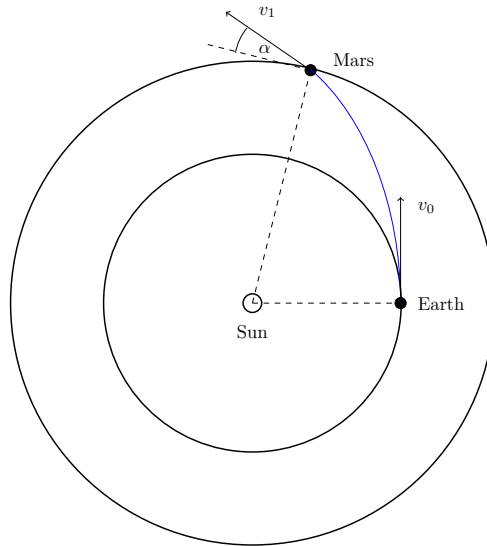

Figure 7: Schematic representation of the motion of the spacecraft between the planets.

The spacecraft enters the sphere of gravitational influence of Mars at a velocity v'_1 relative to the rest frame of Mars. Let us denote by β the angle which this velocity makes with the direction of Mars's motion. After the flyby, the direction of this velocity changes by an angle θ as indicated in Figure 8. Let us denote the orbital speed of Mars around the Sun as v_M .

- b) Determine the heliocentric speed v_2 of the spacecraft after it escapes the gravity of Mars. Express your result in terms of the angles θ , β and the speeds v'_1 and v_M .

It can be shown that the angle θ can be computed as

$$\tan \frac{\theta}{2} = \frac{GM}{bv_1'^2},$$

where M is the mass of Mars and b is the impact parameter of the spacecraft trajectory (perpendicular distance from Mars of the line along which the spacecraft approaches Mars in its rest frame, see Figure 8). The magnitude of b can be varied independently of the other parameters.

- c) Formulate a criterion on the value of the impact parameter b (and hence the deflection angle θ) which maximizes the speed v_2 for a given value of

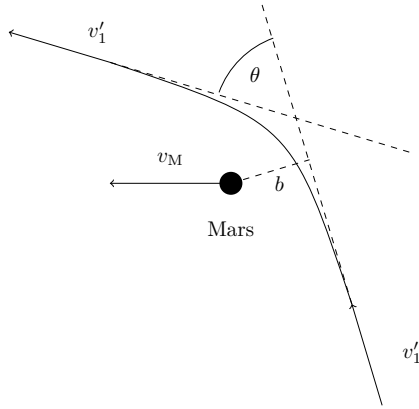

Figure 8: Geometry of the Mars flyby.

v_1' . For the sake of simplicity, you should neglect any effects due to non-zero dimensions of Mars. Find this maximum speed $v_{2,\max}$ as a function of the initial speed v_0 and the parameters η, χ .

- d) Find the minimum value of the initial heliocentric speed v_0 which would enable the spacecraft to leave Solar System using the gravitational slingshot maneuver involving Mars. Express your result as a multiple of u_E . Consider the radii of the circular orbits of the Earth and Mars around the Sun to be $a_E \simeq 1 \text{ au}$ and $a_M \simeq 1.524 \text{ au}$.

a) $v_1 = v_0 \sqrt{1 - \eta(1 - \chi)}$, $\cos \alpha = v_0 a_E / (v_1 a_M) = \chi / \sqrt{1 - \eta(1 - \chi)}$;

b) $v_2 = \sqrt{v_1'^2 + v_M^2 + 2v_1'v_M \cos(\beta - \theta)}$;

c) $v_{2,\max}/v_0 = \sqrt{\eta\chi/2 + \sqrt{1 - \eta + (3/2)\eta\chi - \chi\sqrt{2\eta\chi}}}$; d) $0.838u_E \simeq 35 \text{ km s}^{-1}$

Gravitational deflection

CD/N/6

In this problem, we will imagine a near catastrophic scenario when an asteroid arrives in Earth's close vicinity. Fortunately for mankind, it does not collide with the Earth, but instead just flies by and changes its direction. The angle between the incoming geocentric velocity \mathbf{v}_{in} and the outgoing geocentric velocity \mathbf{v}_{out} of the asteroid will be referred to as the *deflection angle* and denoted by Δ . See also Figure 9. Your sole job in this problem will be to derive an expression for Δ .

Before attempting this calculation, let us remind ourselves of a number of basic facts about the motion of particles in a central gravitational force field. Denoting by M the mass of the central gravitating body and by m the mass

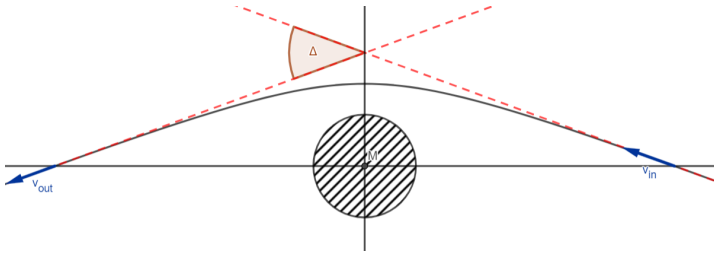

Figure 9: Illustration of gravitational deflection. The figure is not entirely accurate, as the vectors \mathbf{v}_{in} and \mathbf{v}_{out} are supposed to represent the velocity of the incoming and outgoing particle *at infinity* (that is, outside of the sphere of influence of the gravitational field). The two dashed straight lines will be referred to as the *incoming* and *outgoing* asymptotes.

of a test particle moving in the gravitational field generated by M , the total mechanical energy E of the particle along its trajectory can be expressed as

$$E = \frac{1}{2}mv^2 - \frac{GMm}{r},$$

where r is the separation of the test particle from the central body and v is its instantaneous speed. The strength of the gravitational interaction is measured by the Newton's constant $G \simeq 6.67 \times 10^{-11} \text{ N m}^2 \text{ kg}^{-2}$. The energy E is a constant of the particle's motion in the field generated by M .

The types of trajectories along which the particle can move fall into the following three classes based on the value of E :

1. $E < 0$: The trajectory is an *ellipse* or a *circle*. The test particle is *gravitationally bound* to the central body M (i.e. it can never escape to infinity).
2. $E = 0$: The trajectory is a *parabola*. The test particle is not bound to the gravitating body but its speed at infinity will be exactly zero.
3. $E > 0$: The trajectory is a *hyperbola*. Again, the test particle is not gravitationally bound to the central body and can escape to infinity where its speed will be non-zero.

The focus of this problem will be on the case where the test particle (an asteroid) moves in the Earth's gravitational field along a hyperbola. A couple of comments special to this type of trajectory are therefore in order (see also Figure 10 for illustrations):

- Similar to the case of an ellipse, we define the *major* and *minor semi-axes* a and b , *linear eccentricity* $e = \sqrt{a^2 + b^2}$ and *numerical eccentricity* $\epsilon = e/a = \sqrt{1 + b^2/a^2}$.
- A hyperbola has two foci, which we denote by M and F. While the focus M is the location of the gravitating body M , the focus F is generally empty.
- A hyperbola is a curve which consists of two disconnected pieces which are called branches. The test particle moves along the branch which is adjacent to the focus M.
- A hyperbola has two asymptotes. These are straight lines that are approached by the branches as one moves further away from the foci. The test particle arrives along the incoming asymptote (Asymptote_{in} in the figure) and departs along the outgoing asymptote (Asymptote_{out} in the figure).

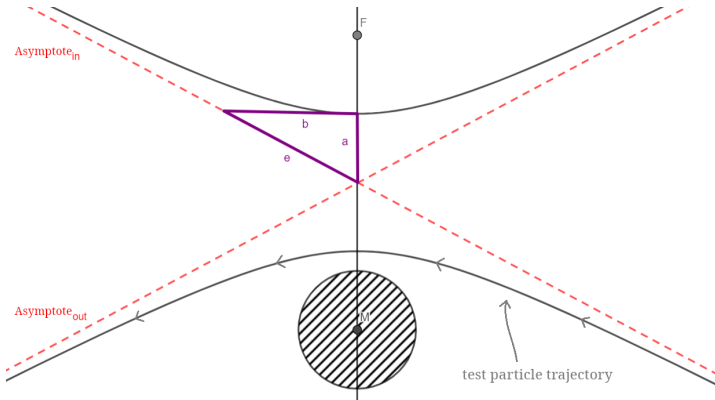

Figure 10: Geometry of a hyperbola.

At this point, let us introduce one more quantity, namely the *impact parameter* b_∞ . This measures the distance between an asymptote and its parallel that passes through a focus, as shown in Figure 11.

We will find it useful to know the relationship between the energy $E > 0$ of the test particle and the semi-major axis $a > 0$ of the hyperbola along which it moves. This reads

$$E = \frac{GMm}{2a}.$$

Energy is not the only quantity which is conserved as the test particle moves in the gravitational field of the central body M : another constant of motion is provided by the *angular momentum* of the particle, whose magnitude can

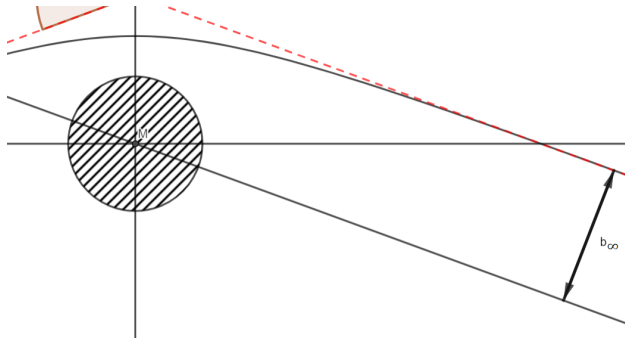

Figure 11: Impact parameter.

be expressed as

$$L = mvr_{\perp},$$

where r_{\perp} is the distance between the straight line generated by the velocity vector of the particle (i.e. the straight line along which the particle would start moving if the gravitational interaction were to be instantaneously turned off) and its parallel, which passes through the focus M . For example, if the particle is at infinity, we simply have $r_{\perp} = b_{\infty}$. The angular momentum of such a particle then has magnitude

$$L = mv_{\infty}b_{\infty},$$

where v_{∞} denotes the speed of the particle at infinity.

This much for an introduction, it is now time for you to tackle the following questions.

- The asteroid arrives to the Earth along the an incoming asymptote with geocentric velocity \mathbf{v}_{in} whose magnitude we will denote by v_{∞} . Find the semi-major axis a in terms of G , the mass of the Earth M and v_{∞} .
- Find the distance b_c of the asteroid's closest approach to the center of the Earth. Express your answer in terms of a and the impact parameter b_{∞} of the asteroid's trajectory.
- Assuming that the asteroid approaches the Earth as close as the orbit of the Moon (whose radius we will denote by R), find the impact parameter b_{∞} in terms of a and R .
- Find an expression for the numerical eccentricity of the asteroid's trajectory in terms of the semi-major axis a and the impact parameter b_{∞} .

Hint: particle with energy E and angular momentum L moves along a trajectory with eccentricity

$$\epsilon = \sqrt{1 + \frac{2L^2E}{G^2M^2m^3}}.$$

- e) Find the minor semi-axis b of the asteroid's trajectory as a multiple of b_∞ .
 f) Having passed by the Earth, the asteroid departs towards infinity along the outgoing asymptote which makes an angle Δ with the incoming asymptote. Find $\tan \frac{\Delta}{2}$ in terms of a and b_∞ .
 g) Recast the expression for Δ you found in part f) in terms of the quantities G , M , R and v_∞ . Find an approximation to this result in the regime $GM/Rv_\infty^2 \ll 1$.

Hint: the function $\tan x$ can be expanded into a power series whose leading terms are

$$\tan x = x + \frac{x^3}{3} + \frac{2x^5}{15} + \dots,$$

- h) Compute Δ numerically for $M \simeq 5.974 \times 10^{24}$ kg, $v_\infty \simeq 10$ km s $^{-1}$, $R \simeq 3.84 \times 10^5$ km and $G \simeq 6.67 \times 10^{-11}$ N m 2 kg $^{-2}$.

- [a] $a = GM/v_\infty^2$; b) $b_c = -a + \sqrt{a^2 + b_\infty^2}$; c) $b_\infty = R\sqrt{1 + 2a/R}$; d) $\epsilon = \sqrt{1 + b_\infty^2/a^2}$;
 e) $b = b_\infty$; f) $\tan(\Delta/2) = a/b_\infty$;
 g) $\Delta = 2 \arctan \left[(GM/Rv_\infty^2)(1/\sqrt{1 + GM/Rv_\infty^2}) \right] \approx 2GM/Rv_\infty^2$; h) $\Delta \simeq 1.2^\circ$

Disintegrating moon

AB/R/1

The gas giants in our Solar System generate strong enough gravitational fields to allow them to retain tens of moons and moonlets. Closer to these planets, their gravity can become so strongly varied that it would cause an entire moon to break up, thus forming a ring. In this problem, you will find the limiting distance between a moon and a planet at which the moon begins to disintegrate.

Consider a planet with radius R and density ρ_p together with its moon with radius r and density ρ_m . We will examine two modes in which the moon can rotate about its axis: a non-rotating moon and a tidally locked moon. Owing to the complexity of this problem, we will adopt several simplifying assumptions. In particular, we will assume that 1. the mass of the moon is much less than the mass of the planet, 2. the planet remains at rest while the moon revolves around it along a circular trajectory of radius d , 3. the moon is a rigid and homogeneous sphere which does not yield to any deformations caused by inhomogeneities of the planet's gravitational field, and finally, 4. the

radius of the moon is much smaller than the radius of its trajectory around the planet, that is $r \ll d$.

- a) Produce a sketch of the planet with the moon and mark (with the letter A) the point on the moon's surface which is closest to the planet. The point A moves along a circular path around the planet. Determine the radius of this orbit for both modes of the moon's rotation.
- b) In both cases, find the square of the angular speed ω of the point A.
- c) Imagine that an observer is located at the point A on the surface of the moon. For both modes of rotation, find the total acceleration which she experiences. Consider both modes of rotation. In the case of a non-rotating moon, compute the acceleration at the instant when the point A is closest to the planet.
- d) Consider now that the radius of the moon's orbit slowly decreases. What is the distance at which the moon starts to disintegrate? Again, you should work out the answer separately for both modes of rotation.

Hint: set the total acceleration to zero and use the binomial approximation $(1+x)^n \approx 1+nx$ for $x \ll 1$.

[a] $d-r$, d ; b) $\omega^2 = 4\pi R^3 \rho_p G / 3d^3$, same for both cases of rotation;

c) $\frac{4\pi G}{3} [R^3 \rho_p / d^2 + r \rho_m - R^3 \rho_p / (d-r)^2]$, $\frac{4\pi G}{3} [R^3 \rho_p (d-r) / d^3 + r \rho_m - R^3 \rho_p / (d-r)^2]$;

d) $\sqrt[3]{3R^3 \rho_p / \rho_m}$, $\sqrt[3]{2R^3 \rho_p / \rho_m}$

Tisserand's invariant

AB/N/6

Close approaches between the planets and minor bodies (asteroids or comets) of Solar System are very common. As a consequence, the orbits of minor bodies can change drastically over a very short time interval. The aim of this problem will be to construct a certain function (the *Tisserand's parameter*) of orbital elements, such that its value remains unchanged when the asteroid's orbit is perturbed as a result of a close encounter with a planet. It should follow that this quantity is very useful for studying apparent discontinuities in orbital evolution of minor bodies in Solar System.

Consider a setup in which an object (a planet) of mass m orbits in a circular trajectory with radius R around a large central body (a star) of mass $M \gg m$.

- a) Write down an expression for the orbital speed V of the planet around the central star in terms of G , M and R .

In addition, let us consider a small object (an asteroid) with mass $\mu \ll m \ll M$, which orbits the central star in an elliptical trajectory with semi-major axis a and eccentricity e . Let us denote by i the inclination of the asteroid's orbit with respect to the plane of the planet's orbit. For the sake of simplicity,

let us first assume that $i = 0$.

- b) Write down an expression for the speed v of the asteroid as it passes at the distance R from the central body. Express your result in terms of V , R and a .
- c) Find the projection v_{\parallel} of the asteroid's velocity in the direction tangent to the planet's orbit. Express your result in terms of V , R , a and e .

Now suppose that a close approach between the asteroid and the planet takes place.

- d) Calculate the speed u (relative to the planet) at which the asteroid enters the planet's sphere of gravitational influence. Express your result in terms of the quantities V , R , a and e .
- e) Discuss what adjustments would need to be made to the result of part c) for the projection v_{\parallel} in the case of a non-zero inclination i .
- f) Similarly, explain how your answer in part d) would change in the case of non-zero inclination i . In particular, express u in terms of V and the *Tisserand's parameter*

$$\mathcal{T} = \frac{R}{a} + 2\sqrt{\frac{a}{R}(1 - e^2)} \cos i.$$

This we can understand as a function $\mathcal{T}(a, e, i)$ of the orbital elements a , e and i of the asteroid.

The elements of the asteroid's orbit are expected to change as a consequence of the close encounter with the planet. Let us denote their new values as a' , e' and i' .

- g) Justify why the value of the Tisserand's parameter of the asteroid's orbit does not change after the asteroid makes a close encounter with the planet. In other words, show that

$$\mathcal{T}(a, e, i) = \mathcal{T}(a', e', i').$$

In October 2018, the asteroid 2018 UA was observed to exhibit a sudden change in its orbital elements: the original values $a \simeq 2.873 \times 10^{11}$ m, $e \simeq 0.5470$, $i \simeq 6.368^\circ$ changed within a few days to new values $a' \simeq 2.080 \times 10^{11}$ m, $e' \simeq 0.4474$, $i' \simeq 2.644^\circ$. It is therefore natural to suspect that the asteroid underwent a close flyby either at the Earth or at Mars.

- h) Calculate the orbital radius R of the perturbing body. Use this result to decide whether the planet passed by the Earth or Mars. For the sake simplicity, assume that the orbital inclination of the perturbing body relative to the plane of the ecliptic was zero.

- [a] $V = \sqrt{GM/R}$; b) $\sqrt{2 - R/a} V$; c) $\sqrt{(a/R)(1 - e^2)} V$;
 d) $[3 - R/a - 2\sqrt{(a/R)(1 - e^2)}]^{1/2} V$; e) $\sqrt{(a/R)(1 - e^2)} V \cos i$; f) $u = \sqrt{3 - T} V$;
 h) $R = \left\{ [(2aa')/(a' - a)] [\sqrt{a'(1 - e'^2)} \cos i' - \sqrt{a(1 - e^2)} \cos i] \right\}^{2/3}$, 1.499×10^{11} m,
 Earth]

Stellar astronomy and radiation

How hot is it inside a star?

AB/R/2

Stars can be thought of as dense spherical clouds of hot, ionised gas that continue to emit radiation for billions of years due to thermonuclear fusion of hydrogen into helium taking place in their core. In this problem, you will take a closer look at certain aspects of this process.

Let us model a star as a sphere made of pure ionized hydrogen (protons and electrons equally distributed in the star) which, to a good degree of approximation, behaves as an ideal gas. From the point of view of classical physics, the fusion of two hydrogen nuclei (as point objects) can occur whenever they come within each other closer than $d \simeq 10^{-15}$ m. This is the scale at which the strong interaction starts to dominate, and the repulsive Coulomb interaction can no longer prevent the nuclei from fusing.

- a) Assuming that the protons inside the star move with the root-mean-square velocity $v_{\text{sq,p}}$, estimate the minimum temperature T of the ideal gas inside the star which would enable the nuclei to come within the distance $d \simeq 10^{-15}$ m from one another. Ignore the loss of energy due to bremsstrahlung.

To decide whether this calculation does or does not give a reasonable estimate of the temperature inside a star, we need find another independent way of computing it.

To this end, it proved convenient to invoke the condition that, as a whole, the star needs to be in hydrostatic equilibrium. This is an intricate balance between the star's tendency to collapse under its own gravity on one side, and a pressure gradient which is fed a decreasing temperature profile on the other. Mathematically, this can be expressed as

$$-\frac{\Delta P}{\Delta r} = \frac{Gm(r)\rho(r)}{r^2},$$

where R is the radius of the star, $0 \leq r \leq R$ denotes the distance from the center of the star, ρ is the density and $m(r)$ denotes the total mass of the star deposited at radii less than r . On the other hand, on the left hand side, ΔP

denotes the difference in the pressure above and below a thin spherical shell of thickness Δr . Finally, G is the gravitational constant.

- b) Use the equation of hydrostatic equilibrium to estimate the temperature T of the ideal gas in the core of a star. Your result should only depend on the mass and the radius of the star, as well as on some fundamental constants. You should ignore all complexities involved in dealing with structure of real stars.
- c) Using the result of part b), find the ratio M/R as a function of temperature and fundamental constants only.
- d) In part a), you have determined a lower bound on the temperature T which followed from classical considerations involving the microscopic details of the processes leading to thermonuclear fusion. Upon substituting this temperature into the relation for M/R derived in part c), this would, in principle, give a lower bound $(M/R)_{\min}$ on this ratio. Find this lower bound numerically and compare with the value of M_{\odot}/R_{\odot} . What does this result mean? Comment briefly.

Your results in part d) should prompt you to revisit the calculation we did in part a). In particular, let us now take into account the quantum (wave) nature of the two colliding protons. This should yield an improved estimate for the minimum core temperature of a star in order for a thermonuclear reaction to take place.

Let us denote the de Broglie wavelength of a particle with velocity $v_{\text{sq,p}}$ as λ_{p} . With this concept in mind, one can note that due to the onset of quantum tunneling, the distance at which the two protons need to come to each other in order for fusion to occur is in fact $d = \lambda_{\text{p}}/\sqrt{2}$.

- e) Find an improved estimate for the minimum temperature T which is required in order for thermonuclear fusion to take place (taking quantum behaviour into account).
- f) Use this estimate to reassess the lower bound on the ratio M/R computed in part d). Comment briefly.

In part f), you should have found that the lower bound on the ratio M/R can be expressed only in terms of fundamental constants. It would therefore appear that the mass of a star which burns hydrogen in its core can, in principle, be arbitrarily small. We will now see that this is not entirely true, because as M decreases, one of our key assumption breaks down.

In order for the gas which forms a star to be considered ideal, the mean distance between the gas particles must be greater than their de Broglie wavelength.

- g) Show that electrons have a larger de Broglie wavelength than protons at

the same temperature.

The mean distance d_e between electrons must be greater than their de Broglie wavelength λ_e , otherwise the electron gas would become degenerate and would have different properties than if it were ideal.

h) Use this information to determine the minimum mass and minimum radius of a star so that electrons can still be considered an ideal gas. Express your results in multiples of the radius and the mass of the Sun.

- [a) 5.6×10^9 K; b) $GMm_p/(2kR)$; c) $M/R = 2kT/(Gm_p)$; d) $(M/R)_{\min} \simeq 1.4 \times 10^{24}$ kg m⁻¹, $(M/R)_{\text{Sun}} \simeq 2.9 \times 10^{21}$ kg m⁻¹; e) $q^4 m_p / (24\pi^2 \epsilon_0^2 k h^2) \simeq 9.8 \times 10^6$ K;
 f) $q^4 / (12\pi^2 G \epsilon_0^2 h^2) \simeq 2.4 \times 10^{21}$ kg m⁻¹; g) $\lambda = h / \sqrt{3kTm}$;
 h) $(1/\sqrt{2})[\epsilon_0^{1/2} h^2 / (qm_e^{3/4} m_p^{5/4} G^{1/2})] \simeq 0.10 R_{\text{Sun}}, 0.09 M_{\text{Sun}}$

Solar power plant maintenance

AB/N/3

An advanced civilization decides to cover part of its electricity demand by building a photovoltaic power plant in space. By positioning the solar panels perpendicular to the incoming radiation from the star around which their planet orbits, they are able to ensure that the panels receive the maximum possible flux $k = 1400$ W m⁻². One of the problems which the power plant maintenance team has to deal with is the declining efficiency of the panels which, initially, was as much as 50%. When the efficiency drops down to 30%, the engineers are required to replace the panel with a new one. However, to make the matter more complicated, the rate of degradation of the panels is highly inhomogeneous. Therefore, it certainly would not pay off to replace all panels after a certain period of time has elapsed since installation. To detect which panels should be scheduled for replacement, engineers came up with the idea to monitor the efficiency of the loaded panels with a thermal camera (a panel is said to be loaded when it is connected to the power grid from which electricity is drawn).

- a) Assume that a critical panel temperature T_c corresponds to the panel having an efficiency of 30%. Decide whether one should replace all panels with a lower or a higher temperature than T_c .
 b) Determine the critical temperature T_c of a loaded solar panel with an efficiency of 30% which is in thermodynamic equilibrium with its surroundings. Assume that the panel takes the shape of a planar plate that absorbs all incident radiation and radiates as a black body from both its surfaces. Find also the temperature of a new panel T_n with an efficiency of 50%. Express both temperatures in K.

- [a) higher; b) $T_c \simeq 305$ K, $T_n \simeq 280$ K]

Binary systems, clusters and exoplanets

The binary β Aur

EF/R/2

In this problem, we will be dealing with multiple star systems which are called *spectroscopic binaries*. These are binaries whose components were only resolved based on the measurements of their combined spectrum.

Due to the so-called *Doppler effect*, the observed wavelength of radiation can change depending on the relative speed of the observer and the object which emits the radiation. As the individual stars in a binary system orbit around their center of mass, it follows that this motion will be reflected in the positions of spectral lines in the combined spectrum of the two components.

In Figure 12, a time series of spectra of the binary system β Aur is shown. As we can see, particular emphasis is put on the region around the $H\alpha$ line, whose laboratory wavelength is equal to $\lambda_{\text{lab}} \simeq 656.281$ nm. The spectra were obtained using the Lhires III instrument of the Club d'Astronomie de Lyon-Ampère (CALA). At the same time, β Aur is an eclipsing variable star, whose light curve (obtained by the satellite WIRE) is displayed in Figure 13. In both figures, time dependence is indicated in terms of the so-called *orbital phase*: a number which uniformly increases from 0 to 1 over one orbital period, where the values 0 and 1 correspond to the primary minimum. Both types of measurements (spectroscopic and photometric) yield the same value of the binary's orbital period, namely $P \simeq 3.960$ d.

In the following questions, we will assume that the stars orbit uniformly in circular orbits around the common center of mass of the system and that our line of sight passes through the orbital plane.

- Determine the mean value λ_0 of the wavelength about which the two components of the spectral line $H\alpha$ oscillate in time. Give the result in nm to two decimal places.
- Decide whether the barycenter of the system is moving towards or away from the observer.
- Find the radial speed v_r with which the system approaches or recedes from the observer. Express your result in km s^{-1} to two significant figures.
- Determine the maximum displacement $\Delta\lambda$ of the two components of the $H\alpha$ line from the mean wavelength λ_0 . Give the result in nm to two decimal places.
- Make schematic drawings showing the binary system at the times corresponding to the phases 0, 0.25, 0.5 and 0.75 when viewed from above the orbital plane. In each drawing, mark 1. the direction to the observer, 2. the positions of the two stars, 3. the position of the barycenter of the sys-

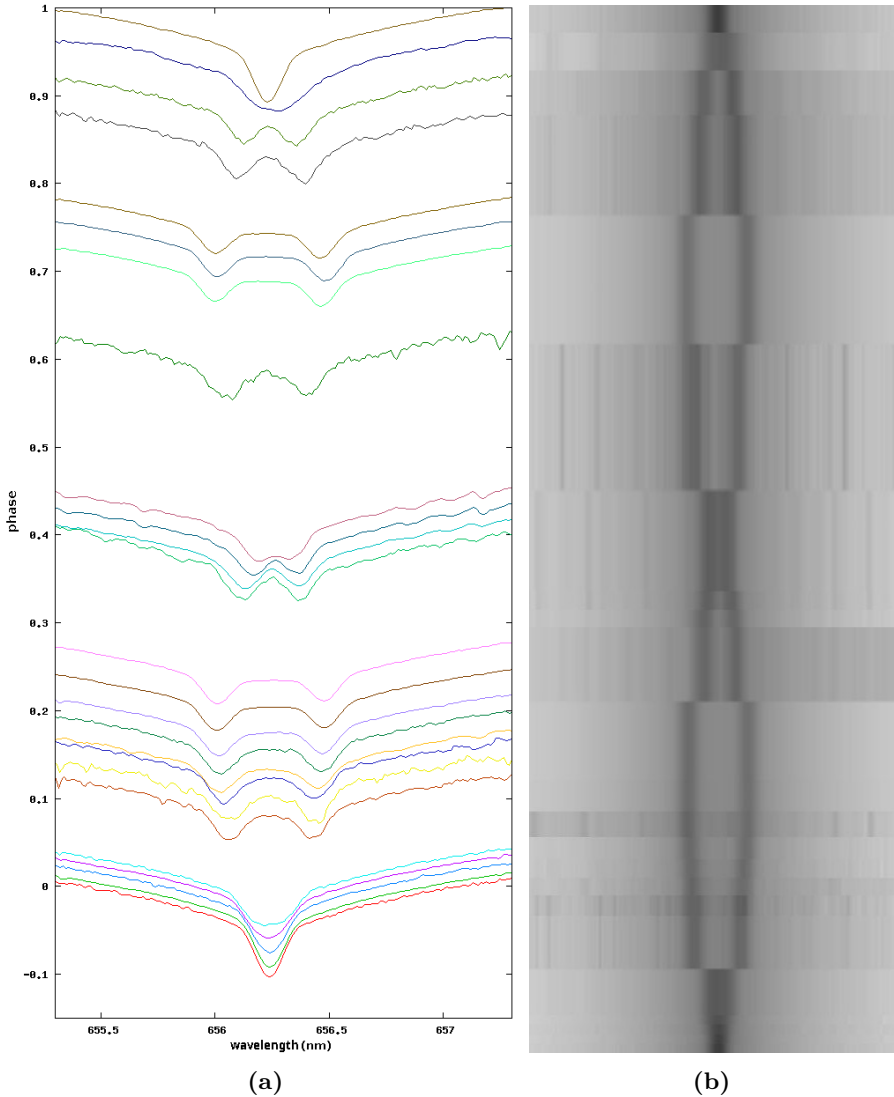

Figure 12: A time series of spectroscopic measurements of β Aur. An interval of wavelengths around the position of the H α line is shown. In Figure (a), the spectra are represented by plotting the measured intensity against the wavelength. The orbital phase corresponding to the moment at which a spectrum was measured can be read off the vertical axis. In Figure (b), the actual images of the spectra are shown. Credits: CALA.

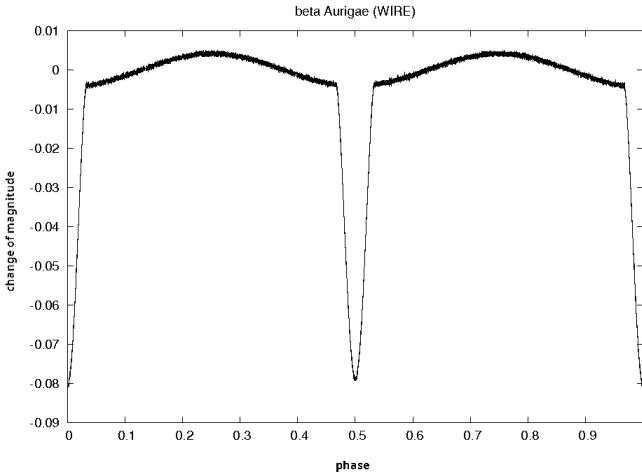

Figure 13: Light-curve of the binary β Aur. Credits: Southworth et al. (2007).

tem, as well as 4. the line joining the two components and the barycenter.

What can you say about the ratio of the masses of the two components?

- f) Calculate the maximum radial speed v_m of each star relative to the observer. Give the result in km s^{-1} to three significant figures.
- g) Determine the orbital speed v_o of the two components.
- h) Find the orbital radii r of the stars around the barycenter. Express your result in au to two decimal places.
- i) Find the magnitude a_d of the centripetal acceleration which the two stars experience in their orbits. Express your result in terms of v_o and r .

Recalling the 2nd Newton's law, we can realize that the magnitude of the centripetal acceleration of the first star must be equal to the magnitude of the gravitational force per unit mass (of the first star) exerted on the first star by the second star. And vice versa.

- j) Determine the mass M of each star. Express your result as a multiple of solar masses.

[a] 656.24 nm; b) approaching; c) 19 km s^{-1} ; d) 0.24 au; e) the two components have identical mass; f) 110 km s^{-1} ; g) $v_o = v_m$; h) 0.04 au; i) v_o^2/r ; j) $2.2M_\odot$]

The Sun and Jupiter

EF/N/2

The Sun makes up for almost 99.87% of the total mass of the Solar System. Jupiter accounts for another 0.10% of the mass, while the remaining objects represent only 0.03% of the total mass. We are therefore well justified (at least for the purposes of the following problem) to reduce the entire Solar System down to just the Sun and Jupiter. You should assume that the distance of Jupiter from the Sun is $r \simeq 5.2$ au and that the masses of these two objects are $M_{\odot} \simeq 1.99 \times 10^{30}$ kg and $M_J \simeq 1.90 \times 10^{27}$ kg.

Any two massive bodies influence each other by the gravitational force, whose magnitude we denote by F_g . If the two bodies are to orbit along circular trajectories in an inertial reference frame where no other forces act, the gravitational force acting on any of the two bodies must be put equal to the corresponding centripetal force, whose magnitude we denote by F_c . Moreover, the following relations hold

$$F_g = \frac{Gm_1m_2}{R^2}, \quad F_c = \frac{mv^2}{r},$$

where G is the Newton's gravitational constant, m_1 and m_2 are the masses of the two bodies and R is their separation. Furthermore, v and r are the orbital velocity and the orbital radius of the body on which the centripetal force F_c acts.

- a) Let us first assume that, from the point of view of the inertial reference frame, Jupiter orbits along a circle whose center coincides with the center of the Sun. By identifying the gravitational force with the centripetal force, determine the speed v_J of Jupiter in its orbit. Give the result in meters per second rounded to the nearest integer.

However, in reality, *both* the Sun and Jupiter turn out to undergo orbital motion relative to an inertial reference frame. In particular, the two bodies turn out to move along circles which are centered at a common point. You should also take it as given that this point always lies on the Sun-Jupiter axis. In particular, it follows that the two bodies orbit uniformly in circles with the same period.

- b) Find the orbital periods of both the Sun and Jupiter (P_{\odot} and P_J) in terms of their orbital speeds v_{\odot} , v_J and their orbital radii r_{\odot} and r_J .
- c) Compare the magnitude of the gravitational force exerted on Jupiter by the Sun with the magnitude of the gravitational force acting on the Sun due to Jupiter. Express your result in newtons to 3 significant figures.
- d) As the Sun and Jupiter orbit in an inertial reference frame in circular orbits around a common point, the gravitational forces acting on each of

the two bodies must be equal to the centripetal forces which keep them on their circular trajectories. Using the result you obtained in part c), compare the centripetal forces acting on the two bodies. Moreover, using your results from part b), express the ratio $r_{\odot} : r_{\text{J}}$ of the orbital radii in terms of the ratio of the masses of the two bodies. Is the common center of the two orbits significant in any way?

- e) Finally, noting that $r = r_{\odot} + r_{\text{J}}$, find the distance r_{\odot} of the common center of the two orbits from the Sun. Is the common center inside or outside the Sun?

[a] $v_{\text{J}} = \sqrt{GM_{\odot}/r} \simeq 13\,062 \text{ m s}^{-1}$; b) $P_{\odot} = 2\pi r_{\odot}/v_{\odot}$, $P_{\text{J}} = 2\pi r_{\text{J}}/v_{\text{J}}$; c) same magnitude $F_{\text{g}} \simeq 4.17 \times 10^{23} \text{ N}$; d) $M_{\odot}/M_{\text{J}} = r_{\text{J}}/r_{\odot}$, center of mass; e) $4.96 \times 10^{-3} \text{ au}$, outside]

Eclipsing binary

CD/N/3

Astronomers observe a binary system which consists of two stars with different temperatures and radii. When the disks of the two stars do not overlap, the binary has a magnitude of $m \simeq 15.00 \text{ mag}$. On the other hand, when the smaller star passes in front of the larger star, the observed magnitude increases to $m_{\text{e}} \simeq 15.15 \text{ mag}$. You should assume that at the moment corresponding to the middle of the transit, the centers of the two disks coincide. Spectroscopic measurements show the peak wavelength of the larger star is $\lambda_1 \simeq 290 \text{ nm}$ while peak wavelength of the smaller star is $\lambda_2 \simeq 580 \text{ nm}$. Find the ratio R_1/R_2 of the radii of the two stars (where R_1 denotes the radius of the larger star).

[2.77]

Binary system

CD/N/4

The circular orbits of the components of a binary system with period $P \simeq 80 \text{ d}$ appear on the sky as two identical and concentric ellipses with eccentricities $\epsilon_1 = \epsilon_2 = \sqrt{3}/2$ whose semi-major axes have angular sizes $\alpha_1 = \alpha_2 \simeq 0.2''$. It is also determined that in the combined spectrum of the binary, the line H_{α} (laboratory wavelength $\lambda_0 \simeq 656.28 \text{ nm}$) periodically splits into two components with maximum separation $\Delta\lambda_{\text{max}} \simeq 0.4 \text{ nm}$. Determine the masses M_1 , M_2 of the components of the binary (in solar masses) and the distance d to the system (in parsecs).

[$M_1 = M_2 \simeq 39M_{\odot}$, $d \simeq 3.9 \text{ pc}$]

Cosmology and relativity

Gravitational refraction

AB/N/4

In one of his (unpublished) adventures, the Little Prince landed on the surface of the neutron star HESS J1731-347, which has the smallest mass among all known neutron stars. On a whim, he looked up at the sky and started counting the stars which he can see. After a moment, he realized that he was able to see a considerably large portion of the sky than from his nearby-located home planet. Determine the fraction p of the sky that the Little Prince can see if the neutron star in question has mass $M \simeq 0.8M_\odot$, radius $R \simeq 10$ km and a very large rotation period. You should assume that the Little Prince is really little, so that you can ignore his height.

Hint: general relativity predicts that light-rays passing through the gravitational field of a non-rotating, uncharged spherically-symmetric body are deflected by an angle

$$\Delta = 2\eta + \left(\frac{15}{16}\pi - 1\right)\eta^2 - \left(\frac{15}{16}\pi - \frac{61}{12}\right)\eta^3 + \dots,$$

where $\eta = 2GM/(r_{\min}c^2)$ and r_{\min} is the smallest radial distance at which the light-ray approaches the center of the gravitating body.

[65 %]

Beetle Baggins the astronomer

AB/N/5

Not many people know this, but Beetle Baggins² was a decent amateur astronomer. He therefore hardly caught off his guard when one day, he found himself on a reconnaissance spacecraft with mass $m \simeq 1.0$ t at an unknown place in our Galaxy. First, he used the directions to distant stars to define a Cartesian coordinate system (x, y, z) with its origin corresponding to the position of his spacecraft.

After a short while, Beetle Baggins noticed that at a distance $\varepsilon \simeq 3.0$ km in the positive direction of the x axis, there is a spacecraft which is precisely identical to his. However, he does not notice the nearby Schwarzschild black hole with mass $M \simeq 1.0 M_\odot$ at a distance $r \simeq 7.0 \times 10^5$ km in the negative x direction because he is unable to see it. The just-described configuration of the three objects at the time $t = 0$ is shown in Figure 14. You should assume that both spacecraft orbit the black hole in circular orbits in the (x, y) plane.

²https://cs.wikipedia.org/wiki/Brouk_Pytl%C3%ADk (in Czech)

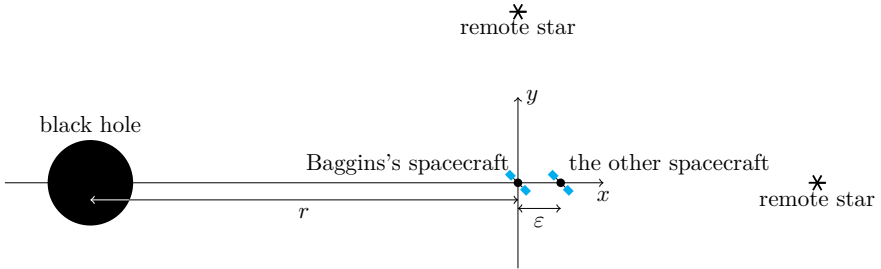

Figure 14: Positions of the two spacecraft and the black hole at the time $t = 0$ in the “top” view (from the positive direction of the z axis). Beetle Baggins sits in the spacecraft closer to the black hole. The two spacecraft orbit the black hole in the (x, y) plane. The coordinate system is defined relative to the distant stars.

Beetle Baggins is well equipped with instruments with which he can measure 1. time, 2. positions and brightness of nearby stars, 3. the distance to the other spacecraft and 4. its position relative to the stars. Unfortunately, he is unable to control the motion of his own spacecraft.

First, let us be clear about what approximations we can afford to use.

- Justify that the effects of general relativity can be neglected, and, although both spacecraft orbit a black hole, use of classical physics will suffice.
- Find the force F_s (in N) that the two spacecraft exert on each other. Find the change Δl (in m) in the distance of the two spacecraft over a period of 1 year if it were not for the presence of the black hole and if the two spacecraft started at zero relative speed. Based on these results, decide whether it is necessary to consider the mutual gravitational interaction of the two spacecraft (at short enough time scales).

Hint: in parts c) and d) you may find the following approximate relations (which hold for $|x| \ll 1$) useful

$$\begin{aligned} (1+x)^n &\approx 1+nx, & n \in \mathbb{R}, & \quad |x| \ll 1/|n| \\ \sin(x) &\approx x, \\ \cos(x) &\approx 1. \end{aligned}$$

You may also need to make use of the following relations for trigonometric functions

$$\begin{aligned} \sin(\alpha \pm \beta) &= \sin \alpha \cos \beta \pm \cos \alpha \sin \beta, \\ \cos(\alpha \pm \beta) &= \cos \alpha \cos \beta \mp \sin \alpha \sin \beta. \end{aligned}$$

- c) Find the period T and the angular speed ω with which the spacecraft of Beetle Baggins orbits the black hole. Find the difference $\Delta\omega$ of the angular speed of the two spacecraft.
- d) Beetle Baggins observes that the other spacecraft is moving relative his rest frame. Find its position vector $(x(t), y(t))$ as a function of time. You should work on a time scale such that $|\Delta\omega t| \ll 1$. You may neglect any terms containing $\varepsilon\Delta\omega$, ε^2 , $\Delta\omega^2$ or higher powers thereof, as these are negligibly small quantities.

Beetle Baggins kept observing the other spacecraft for many orbits around the black hole. (Remember that Baggins is unaware of the black hole!) He found that the other spacecraft was spiraling away from him. We are now talking about a time scale t which satisfies

$$\frac{\varepsilon}{r} \ll \frac{1}{\omega t} \ll 1,$$

You can use these assumptions in all remaining parts of the problem.

Beetle Baggins is no chump and has studied astronomy from books, so he interpreted the increasing separation of the two spacecraft as a consequence of the expansion of the universe. The distance between the two spacecraft can be determined e.g by measuring the delay in radio communication (he has a very accurate clock).

- e) What Hubble constant H' did Baggins arrive at based on his observations? First, write down an expression for H' as a function of time and then evaluate it (in $\text{km s}^{-1} \text{Mpc}^{-1}$) after the spacecraft completed $N = 100$ orbits around the black hole since $t = 0$.
- f) Are there ways of determining whether Baggins was interpreting his measurements correctly? Name at least one method which Beetle Baggins could have used to debunk the wild theory which he used to interpret his measurements.

Eventually, Beetle Baggins managed to arrive at the same conclusion as you did in part f) and realized that the weird motion of the other spacecraft could only be explained by the presence of an invisible massive body.

- g) Describe a method of determining the mass of the black hole. Assume that Baggins knows the value of the gravitational constant G .

Note: you should clearly explain which quantities he needs to measure and how he should combine them to obtain the mass of the black hole.

- [a] $\frac{GM}{rc^2} \simeq 2.1 \times 10^{-6}$; b) $7.42 \times 10^{-12} \text{ N}$; c) 2.8 h , $6.2 \times 10^{-4} \text{ rad s}^{-1}$, $-4.0 \times 10^{-9} \text{ rad s}^{-1}$;
 d) $[\varepsilon \cos(\omega t) + \frac{3}{2}\varepsilon \sin(\omega t)\omega t, \varepsilon \sin(\omega t) - \frac{3}{2}\varepsilon \cos(\omega t)\omega t]$; e) $H'(t) = \frac{1}{t}$, $3.05 \times 10^{13} \text{ km s}^{-1} \text{ Mpc}^{-1}$

Practical problems

Camera obscura

EF/R/3

The aim of this problem will be to build a device called *camera obscura* and use it to measure the angular diameter of the Sun.

Basically, a camera obscura (or pinhole camera) is a box with a small hole drilled out in one of its walls. Light-rays from an object outside the box then pass through this hole and create an upside-down image of the object on the opposite wall inside the box (which plays the role of a screen). This principle was used in the past, for example, by painters who could then simply trace the contours of the projected image. Camera obscura can therefore be regarded as an ancestor of modern cameras. A scheme of a camera obscura is shown in Figure 15.

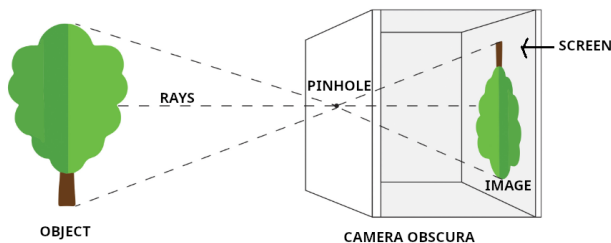

Figure 15: Camera obscura.

a) Build your own camera obscura.

You will need a long straight tube, which should be at least 80 cm long and at least 4 cm in diameter. Material which the tube is made of should be such that a hole can cut out in its cylindrical wall near one of its endcaps. This

hole should be large enough to allow you to see the inner surface of the cap when you look through the hole. You should cover the inner surface of the cap with a piece of graph paper so that the grid is visible when you look through the hole. You should also ensure that the cap is perpendicular to the axis of the tube.

Next, cut out a large enough piece of aluminium foil and cover the other (open) end of the tube with it so that the foil is perpendicular to the axis of the tube. It is important to stretch the foil out so that it is flat and smooth. Then, punch as small a hole as possible exactly at the center of the foil (e.g. using a thin needle). The hole should be circular with as smooth edges as possible.

Your camera obscura should now be ready for observation.

- b) Observe the Sun using your camera obscura. You should NEVER look directly into the Sun. Instead, just observe its image projected onto the graph paper (through the hole cut out in the tube).

It is best to stand with your back turned towards the Sun. You should place the camera obscura over your shoulder holding the end with the graph paper in front of you. To help you aim the tube at the Sun, it is convenient to keep track of the shadow of the tube on the ground in front of you. The shadow should be as small as possible to keep the hole pointed directly towards the Sun. Once you get the tube correctly pointed, you should see a small patch of light on the graph paper (screen). Move the tube carefully until the image is positioned at the center of the cap. Then, try to measure its size by counting the number of lines on the graph paper that the image of the Sun overlaps. We are interested in the diameter of the image, that is, the number of lines starting from one edge of the disk to the other. To increase accuracy, repeat the measurements at least three times and calculate the diameter of the image of the Sun as the average of the individual measurements.

- c) Determine the angular diameter of the disk of the Sun on the sky.

In order to find the angular diameter of the Sun, you will need to measure (in addition to the already measured size of the image) the length of the tube, or more precisely, the distance from the pinhole to the center of the screen. Denoting this distance by d and the measured diameter of the image of the Sun on the screen by D , we can calculate the angular diameter of the Sun in radians as

$$\delta = \frac{D}{d}.$$

- d) Determine the physical diameter of the Sun (in multiples of the diameter of the Earth).

From the measured angular diameter δ of the Sun and the known value of the Earth–Sun distance a , the physical diameter D_{\odot} of the Sun can be calculated as

$$D_{\odot} = \delta a,$$

where δ should be substituted in radians.

Measuring the distance of supernova 1987A CD/N/7

On February 23, 1987, a supernova could be observed in the sky with unaided eye in the direction of the Large Magellanic Cloud. As we shall see in this problem, this unique event provides us with a method of calculating the distance to the LMC. The supernova was surrounded by 3 rings which are shown in Figure 16. We will mainly be interested in the smaller inner ring, which formed some time before the explosion. After the explosion took place, this ring began to glow thanks to the ultraviolet radiation from the supernova.

- a) In Figure 16, you can also see a number of stars which are projected in the vicinity of the supernova. Stars 1 and 2 are separated by an angular distance of $3.0''$, 1 and 3 by $1.4''$, and, finally, the stars 2 and 3 are separated by $4.3''$. Determine the angular size δ of the smaller bright ring around star 1 as measured along the semi-major axis. Remember to indicate your conversion from cm to $''$ (scale).
- b) In reality, the ring takes the shape of an exact circle: the fact that it is observed as an ellipse is due to its plane being rotated by an angle i relative to the plane perpendicular to the line of sight. Find the angular size β of the ring around star 1 along the semi-minor axis. Hence determine the inclination i .

The light curve of SN 1987A is shown in Figure 17. Although radiation from the supernova reached all parts of the inner ring at the same time, to an Earth-based observer it would appear that different parts of the ring were lit up at different times. First, the radiation coming from the part of the ring closest to the Earth was observed and the light-curve reached its maximum when light from the most distant part of the ring reached the Earth.

- c) Determine the linear diameter D of the ring.
- d) Determine the distance d to the supernova.

[a) $\delta \simeq 7.76 \times 10^{-6}$ rad; b) $\beta \simeq 5.76 \times 10^{-6}$ rad, $i \simeq 0.733$ rad; c) $D \simeq 0.408$ pc; d) $d \simeq 52.5$ kpc]

Color excess

CD/N/8

In Table 2, information about 24 stars from a small region of the sky is shown. The stars are identified by their Hipparcos number which is displayed in the

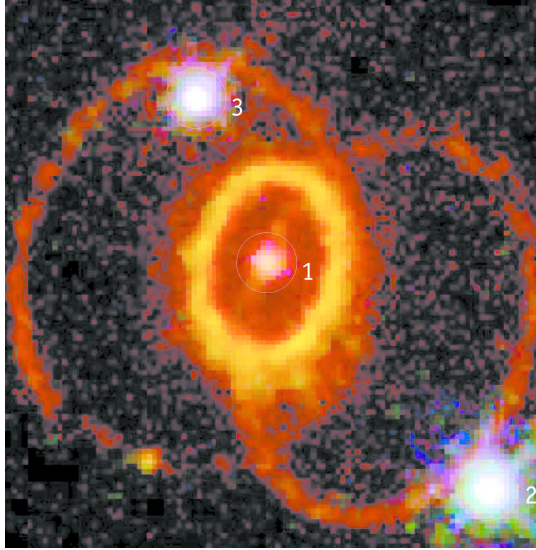

Figure 16: Stars around supernova 1987A. Credits: ESO

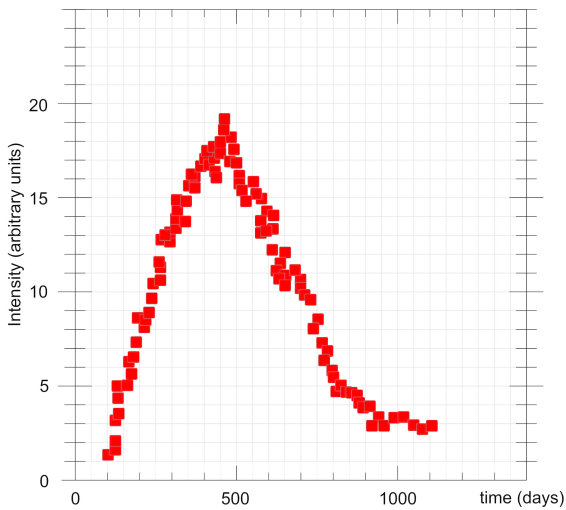

Figure 17: The light curve of the ring around the supernova 1987A. Credits: ESO

second column. The third and the fourth columns show the magnitudes in the B and V filters as observed from the Earth, the fifth column shows the parallax π in milliarcseconds (mas) and, finally, the sixth column shows the spectral type of the star. Table 3 then contains the coordinates of the seven brightest stars from Table 2.

At shorter wavelengths, interstellar dust scatters light more efficiently than at longer wavelengths. Thus, as the photons travel from a star to the Earth, the relative decrease in intensity is greater in the blue part of the spectrum than in the red part. This gives rise to *interstellar reddening* which can be quantified by the *color excess* $E(B - V)$.

Table 2: Stars up to visual magnitude 7.50 mag populating a small region of the sky. Source: SIMBAD <http://simbad.cds.unistra.fr/simbad/sim-fbasic>.

1	2	3	4	5	6
#	HIP number	B (mag)	V (mag)	π (mas)	spectral type
1	76267	2.22	2.24	43.46	A1
2	75695	3.97	3.68	29.17	F2
3	76952 A	4.01	4.05	22.33	A0
4	78159	5.36	4.13	13.49	K2
5	76127 A	4.14	4.30	8.69	B6
6	77512	5.43	4.63	19.50	G5
7	78493	4.92	4.97	8.77	A0
8	77048	6.65	5.58	12.60	G9
9	75312 A	6.12	5.58	55.98	G2
10	75674	7.64	6.02	3.53	M1
11	77397	7.90	6.39	3.94	K5
12	75919	6.64	6.45	5.37	A4
13	76456	6.86	6.46	28.30	F5
14	78429	7.69	6.60	7.45	K0
15	76944	8.09	6.71	4.99	K2
16	78431	8.26	7.06	4.02	K0
17	78709	7.87	7.10	46.23	G8
18	78288	8.25	7.11	6.10	K2
19	76610	7.45	7.21	9.72	A3
20	76993	7.71	7.26	14.42	F8
21	78260	8.90	7.34	3.11	K5
22	77721	8.85	7.36	3.00	K5
23	77373	7.89	7.43	11.01	F6
24	75583	8.83	7.47	2.60	K3

Table 3: Coordinates of the seven brightest stars from Table 2.

#	Bayer d.	HIP number	right ascension	declination	V (mag)
1	α	76267	15 h 35 m 41 s	$26^\circ 38'$	2.24
2	β	75695	15 h 28 m 48 s	$29^\circ 01'$	3.68
3	γ	76952 A	15 h 43 m 44 s	$26^\circ 13'$	4.05
4	ϵ	78159	15 h 58 m 33 s	$26^\circ 48'$	4.13
5	θ	76127 A	15 h 33 m 53 s	$31^\circ 17'$	4.30
6	δ	77512	15 h 50 m 34 s	$26^\circ 00'$	4.63
7	ι	78493	16 h 02 m 23 s	$29^\circ 47'$	4.97

- a) Plot the stars from Table 3 in the coordinate grid provided in Figure 18. Positions of the stars should be marked with disks whose diameter scales with the magnitude of the star in the V filter. Make sure that you indicate the formula which you used to convert between magnitudes and diameters of the disks. Which constellation do the stars come from? Give the English name of the constellation, as well as its IAU abbreviation.
- b) For each star in Table 2, calculate the distance to Earth in parsecs.
- c) For each star in Table 2, calculate its color index $B - V$ as observed from the Earth.
- d) Calculate the absolute magnitude M_V in the visual filter V for the stars in Table 2. Based on the data from Table 4, decide which luminosity class each star belongs to. If any of the stars are borderline between classes I and III or III and V and therefore cannot be unambiguously assigned to either one of the classes, make note of this fact in your answer. You can exclude these stars from further analysis.
- e) Calculate the color excess $E(B - V) = (B - V)_{\text{observed}} - (B - V)_0$ for all stars in Table 2. Whenever the intrinsic color index $(B - V)_0$ for a particular spectral type is missing in Table 4, you should interpolate using the values from the neighbouring rows.
- f) Let the interstellar extinction coefficient (units mag kpc^{-1}) be denoted as A_B in the B filter and as A_V in the V filter. Write down a relation for the color excess $E(B - V)$ as a function of the distance between the observer and the star.
- g) Plot $E(B - V)$ against the distance from Earth and fit the data with a straight line. Determine its slope.
- [f] $E(B - V) = (A_B - A_V)d$; g) $0.1\text{--}1 \text{ mag kpc}^{-1}$

Table 4: Absolute magnitudes and color indices of stars of different luminosity classes. Source: B. W. Carroll, D. A. Ostlie: *An Introduction to Modern Astrophysics*, Cambridge University Press (2017), Appendix G.

spectral type	luminosity class V		luminosity class III		luminosity class I	
	M_V	$(B - V)_0$	M_V	$(B - V)_0$	M_V	$(B - V)_0$
O5	-5.1	-0.33	-5.9	-0.32	-6.5	-0.31
O6	-5.1	-0.33	-5.7	-0.32	-6.5	-0.31
O7	-4.9	-0.32	-5.6	-0.32	-6.6	-0.31
O8	-4.6	-0.32	-5.5	-0.31	-6.6	-0.29
B0	-3.4	-0.30	-4.7	-0.29	-6.9	-0.23
B1	-2.6	-0.26	-4.1	-0.26	-6.9	-0.19
B2	-1.6	-0.24	-3.4	-0.24	-6.7	-0.17
B3	-1.3	-0.20	-3.2	-0.20	-6.7	-0.13
B5	-0.5	-0.17	-2.3	-0.17	-6.6	-0.10
B6	-0.1	-0.15	-1.8	-0.15	-6.4	-0.08
B7	0.3	-0.13	-1.4	-0.13	-6.3	-0.05
B8	0.6	-0.11	-1.0	-0.11	-6.3	-0.03
B9	0.8	-0.07	-0.6	-0.07	-6.3	-0.02
A0	1.1	-0.02	-0.4	-0.03	-6.3	-0.01
A1	1.3	0.01	-0.2	0.01	-6.3	0.02
A2	1.5	0.05	-0.1	0.05	-6.3	0.03
A5	2.2	0.15	0.6	0.15	-6.3	0.09
A8	2.7	0.25	1.0	0.25	-6.4	0.14
F0	3.0	0.30	1.3	0.30	-6.4	0.17
F2	3.4	0.35	1.4	0.35	-6.4	0.23
F5	3.9	0.44	1.5	0.43	-6.4	0.32
F8	4.3	0.52	-	-	-6.4	0.56
G0	4.7	0.58	1.3	0.65	-6.3	0.76
G2	4.9	0.63	1.3	0.77	-6.3	0.87
G8	5.6	0.74	1.0	0.94	-6.1	1.15
K0	5.7	0.81	1.0	1.00	-6.1	1.24
K1	6.0	0.86	0.9	1.07	-6.0	1.30
K3	6.5	0.96	0.8	1.27	-5.9	1.46
K4	6.7	1.05	0.8	1.38	-5.8	1.53
K5	7.1	1.15	0.7	1.50	-5.7	1.60
K7	7.8	1.33	0.4	1.53	-5.6	1.63
M0	8.9	1.40	0.0	1.56	-5.8	1.67
M1	9.6	1.46	-0.2	1.58	-5.8	1.69
M2	10.4	1.49	-0.4	1.60	-5.8	1.71
M3	11.1	1.51	-0.4	1.61	-5.5	1.69
M4	11.9	1.54	-0.4	1.62	-5.2	1.76
M5	12.8	1.64	-0.4	1.63	-4.8	1.80
M6	13.8	1.73	-0.4	1.52	-	-
M7	14.7	1.80	-	-	-	-

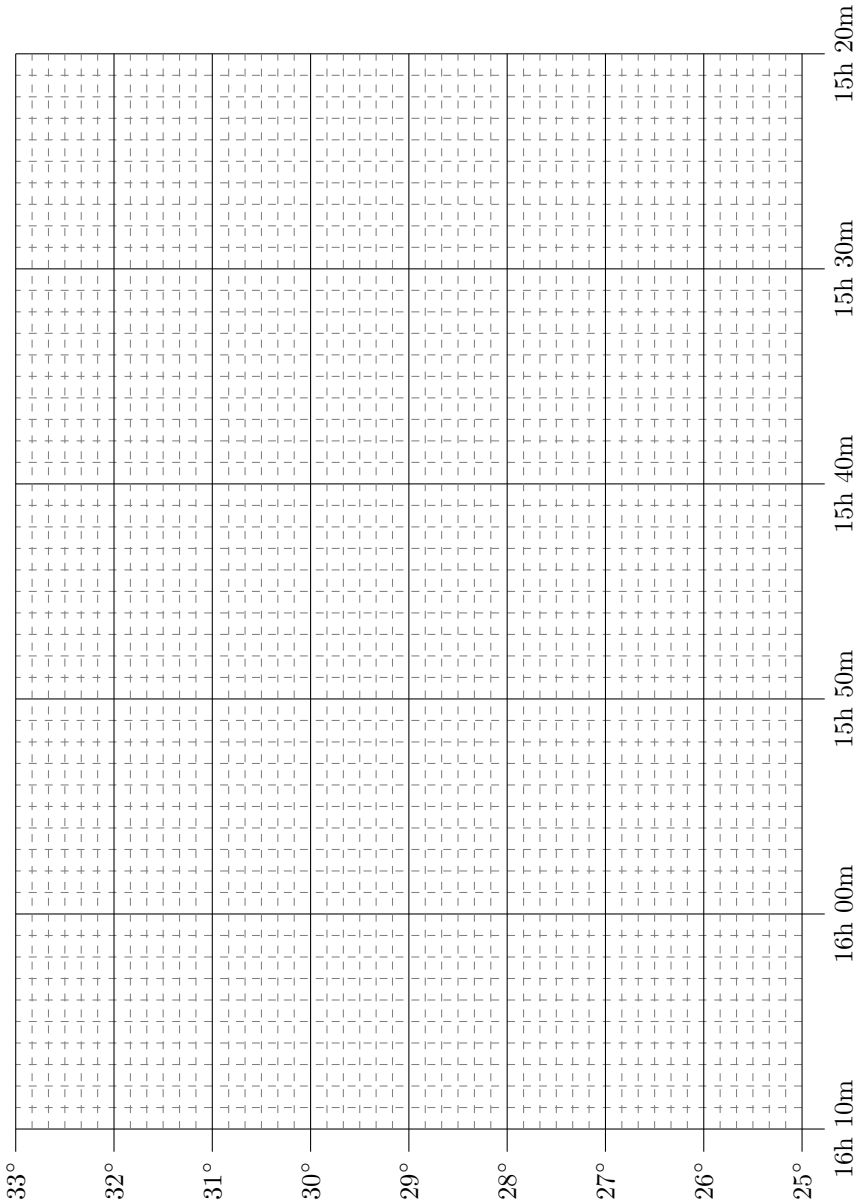

Figure 18: Map for plotting stars.

Dawn and twilight: spheres and cockcrow AB/R/3

In this problem you will try to determine your latitude by observing sunrises and sunsets. You will first calculate your latitude based on the duration of daylight and subsequently try determining it from the duration of sunset.

- a) Measure the times t_1 and t_2 of the sunrise and sunset on the same day. Be sure to make note of the locations where the measurements were taken and the date of your observation. Determine the duration Δt of daytime in hours. Remember to use adequate eye protection!
- b) Find Δt (the time the Sun spends above the horizon) in terms of the declination δ of the Sun and the latitude ϕ of the observer. Non-zero angular size of the Sun should be ignored at this point. Invert this relation to express latitude as a function Δt and δ .
- c) Based on the duration of daylight which you measured in part a) and using your results from part b), determine the latitude of the observation site. Do not forget to give an estimate of its uncertainty. You should find the declination of the Sun for the day of your measurement on the internet.
- d) Measure the duration τ of one sunset, that is, the time which elapses between the moments the upper and lower limbs make contact with the horizon. Specify the location where the observation was performed.
- e) Derive a formula for calculating τ in terms of the latitude and the angular diameter of the Sun on the sky.
- f) Determine the latitude of your observation site by substituting the measured duration τ of sunset into the formula you have derived in part e). Do not forget to estimate its uncertainty.
- g) Compare the two results for the latitude which you obtained using the above-described two methods. Discuss possible influence of atmospheric refraction and deviations of the real horizon from the ideal one. Identify significant sources of errors affecting your measurements and try suggesting improvements in the way you have carried out your observations.

[b) $\Delta t = 2 \arccos(-\tan \phi \tan \delta)$; e) $\tau = (\arccos \frac{-\sin \rho - \sin \varphi \sin \delta}{\cos \varphi \cos \delta} - \arccos \frac{\sin \rho - \sin \varphi \sin \delta}{\cos \varphi \cos \delta}) \frac{12 \text{ h}}{\pi}$]

Estimating the mass of Saturn AB/N/7

The spectrum of the planet Saturn including its rings was observed on February 25, 2002 with the 2.5-meter telescope NOT (Nordic Optical Telescope) of the La Palma Observatory. The slit of the spectrograph was placed over the planet as shown in Figure 19. The base for the observed spectrum (Figure 20) is provided by the solar spectrum as it is reflected off Saturn and its rings. The straight vertical absorption lines arise as the incoming light passes through

the Earth's atmosphere. The inclined absorption lines, on the other hand, are features the reflected solar spectrum. The two strongest lines which can be noticed in Figure 20 are the D1 and D2 neutral sodium lines with laboratory wavelengths 589.0 nm and 589.6 nm, respectively.

In the following questions, you should assume that the rings of Saturn are planar, circular formations which lie in the plane of Saturn's equator and which orbit around Saturn in the same direction as the planet rotates about its axis.

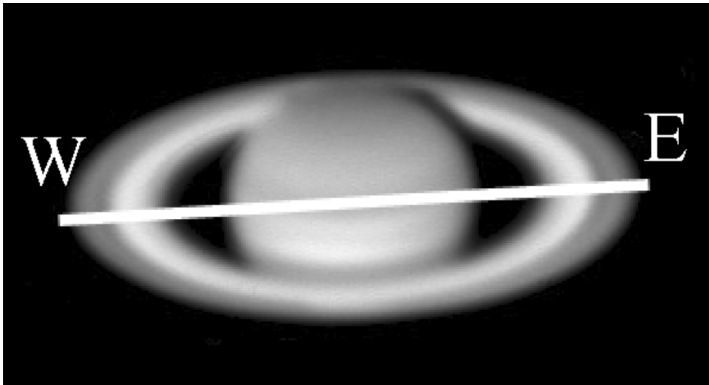

Figure 19: Location of the spectroscopic slit relative to Saturn. West and east are marked as W and E.

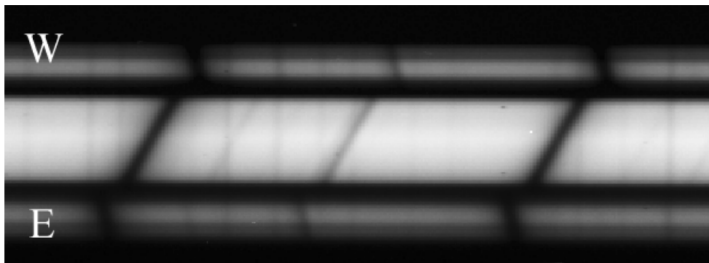

Figure 20: Solar spectrum reflected off Saturn. W and E indicate the orientation of the slit and the wavelength increases from left to right.

- a) Using the spectrum in Figure 20, argue that Saturn's ring is not a solid body, but instead consists of a large number of small particles orbiting the

planet in Keplerian orbits. Produce a sketch of what the spectrum would look like if its ring were a rigid body.

- b) Sidereal period of Saturn’s rotation is equal to $P \simeq 10.66$ h. Using the observed spectrum, determine the equatorial diameter d of the planet (in km).
- c) Determine the mass M of Saturn (in kg).

[b) 120 000 km; c) 5.1×10^{26} kg]

CCD image processing

AB/N/8

In Figure 21, you can see a cropped image of a star field located in the constellation Cepheus (equatorial coordinates of the center R.A. 21 h 47 m 36.1 s and Dec. $57^\circ 11' 39.8''$), which was taken on August 2, 2022 from the Observatory in Valašské Meziříčí (geographic coordinates $49^\circ 27' 50''$ N, $17^\circ 58' 25''$ E) with the CCD camera Moravian Instruments G2-1600 mounted on a 150/750 Newtonian telescope.

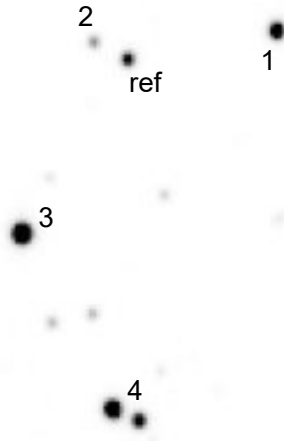

Figure 21: Cropped CCD image.

Along with the image, you are given a table (see Figure 22) of ADU values of the CCD camera pixels for the corresponding field. These values are proportional to the radiative energy incident on each pixel. In order to simplify our analysis, a 4×4 binning is chosen in Figure 22. This means that one cell of the table indicates the total ADU value collected from the area of 4×4 pixels of the CCD chip. You can assume that the dark-frame and flat-field

corrections were already applied to the image and that the exposure time was $t \simeq 180$ s.

213	211	206	206	211	211	212	202	204	214	218	213	208	211	214	215	213	211	215	205	210	213	209	214	218	207	212	
208	205	207	215	204	211	221	204	207	210	210	214	216	208	214	210	209	213	210	209	216	213	212	221	216	226	209	
207	207	214	220	211	209	211	211	207	210	222	205	210	210	208	214	205	208	211	218	225	209	238	328	263	222		
206	209	209	202	209	208	217	220	221	214	210	215	214	212	223	204	216	211	213	210	211	210	226	450	3762	769	234	
206	209	215	205	212	210	208	232	730	419	222	220	210	215	223	209	216	209	210	213	205	209	222	416	3327	679	229	
208	211	207	211	214	203	210	229	586	367	248	593	360	222	204	211	213	211	214	209	206	212	218	230	273	241	217	
206	203	211	210	216	207	205	210	220	223	286	2516	881	226	205	207	211	208	209	206	211	212	214	204	218	210	218	
213	204	207	206	207	204	216	212	215	215	242	460	284	216	217	217	212	209	211	212	212	208	210	209	218	212	215	
215	208	210	208	207	214	216	204	211	213	215	221	215	216	218	211	206	213	204	203	208	210	210	216	204	215		
214	208	205	206	205	204	217	220	229	207	203	210	212	219	214	204	207	205	208	213	204	208	206	205	206	210	200	
208	214	198	206	216	209	208	212	243	219	207	210	211	207	212	199	209	204	202	202	216	210	205	214	215	213	212	
222	210	210	203	210	206	201	204	217	213	206	198	211	204	217	208	214	208	205	205	211	212	212	210	219	209	215	
204	208	208	212	208	201	206	214	215	206	209	200	208	213	214	205	215	208	200	204	213	222	219	208	220	215	214	
215	209	210	220	211	207	211	208	207	214	219	201	209	210	217	210	203	211	202	219	230	210	211	210	213	204	215	
208	217	206	208	209	210	206	205	204	212	209	206	206	211	206	206	213	206	210	207	212	214	208	214	204	214	215	
214	211	214	216	216	224	212	194	203	210	206	203	209	215	211	212	206	206	205	206	208	205	213	211	207	210	219	
216	209	211	214	319	317	204	210	207	204	210	210	219	216	214	214	213	205	203	215	206	202	214	212	206	210	205	
211	209	208	218	230	243	212	208	199	211	202	212	211	217	321	279	223	213	203	212	206	204	209	205	214	212	213	
206	220	228	222	213	203	209	220	209	216	210	211	210	214	398	326	221	213	204	212	200	211	205	213	209	205	217	
209	240	290	251	227	214	205	211	212	208	210	208	210	218	218	220	211	203	210	209	210	214	203	213	265	243	214	
237	486	2445	761	241	221	210	220	222	208	208	205	205	213	205	210	207	218	210	208	214	206	213	222	341	264	224	
240	1214	17017	3018	282	225	220	219	213	204	212	211	215	209	202	211	209	224	209	211	217	209	207	211	223	219	218	
232	452	2282	689	245	213	219	213	213	216	211	205	208	200	211	207	205	206	204	210	202	211	213	207	206	212	212	
213	240	267	238	224	206	209	210	214	213	220	216	215	216	208	204	204	207	215	208	208	206	205	206	212	210	220	
220	216	233	216	203	205	203	210	215	213	209	225	217	210	207	202	207	213	208	211	202	217	213	208	210	212	216	212
206	212	213	213	210	211	209	209	212	212	213	210	211	213	214	202	210	209	210	211	212	217	210	214	205	218	212	
204	216	219	211	210	212	204	211	218	208	207	206	211	204	212	205	215	216	212	206	208	214	216	215	207	209	207	
210	215	216	209	214	211	210	213	300	240	213	216	212	205	214	215	214	214	206	211	204	215	205	208	206	214	208	
205	210	216	212	286	390	220	236	717	328	216	215	209	208	209	213	206	205	203	212	201	206	211	207	207	208	205	
207	215	211	207	347	570	232	221	256	218	204	206	211	211	212	209	206	210	209	205	207	205	207	206	213	205	206	
216	209	214	215	220	219	205	218	208	207	204	208	208	213	218	213	211	210	204	210	209	211	207	205	210	207	214	
215	215	219	221	219	210	208	213	207	211	217	212	211	211	208	213	203	216	214	210	213	214	215	205	204	214	216	
222	220	220	228	209	221	208	203	214	208	213	218	213	212	247	231	228	221	205	214	212	211	213	213	207	210	214	
225	242	208	214	207	207	210	207	216	209	213	219	214	225	365	235	204	217	203	210	210	212	211	217	207	211	207	
198	207	211	209	207	206	207	206	217	225	245	224	219	216	226	218	205	210	214	243	213	211	215	218	217	213	214	
210	215	204	216	220	214	218	210	226	388	873	327	233	221	218	233	214	206	217	247	222	210	215	212	212	213	208	
210	215	212	211	216	215	212	221	248	1408	8761	850	464	308	224	228	210	200	208	213	218	211	208	212	215	212	210	
204	217	207	210	204	212	214	221	231	547	2256	634	3564	973	233	214	213	217	210	214	215	214	204	206	215	205	207	
202	204	214	221	217	207	216	215	224	233	266	288	918	432	244	213	211	213	204	212	221	207	205	205	209	207	203	
217	213	211	214	216	205	217	213	215	213	223	227	238	267	256	215	216	210	205	202	214	211	200	206	212	216	209	

Figure 22: ADU values from the CCD chip (4×4 binning).

- Determine the average ADU value ν_0 corresponding to background (together with its uncertainty).
- Calculate the instrumental (uncalibrated) magnitude of the reference star (marked as ‘ref’ in Figure 21), as well as that of the stars 1 to 3 and the binary star 4 (in mag).

Hint: the instrumental magnitude is defined as

$$m_I = -2.5 \log \Phi,$$

where Φ is the radiative flux from the star in ADU s^{-1} . This, in turn, can be expressed as

$$\Phi = \frac{n_* - n_0}{t},$$

where n_* denotes the total ADU value which corresponds to the star which can be found as the sum of the ADU values collected from a suitably chosen region covering N_* pixels around the star. It is important to realize that from the ADU value n_* , the background ADU value $n_0 = \nu_0 N_*$ must be subtracted. Finally, recall that t denotes the exposure time.

The relation between the instrumental magnitude m_I and the visual magnitude m_V can be expressed as

$$m_I = m_V + a\tau + \Delta m,$$

where a is the total atmospheric extinction at zenith, τ is the (normalized) optical depth of the atmosphere and Δm is some additive constant.

- c) At the time of the observation, the field of interest was at the altitude $h \simeq 70^\circ$ above the horizon. Assume that the extinction coefficient was equal to $a \simeq 0.35$ mag. Using the knowledge of the catalog visual magnitude $m_{\text{ref}} \simeq 12.24$ mag of the reference star, determine the value of Δm (in mag).
 - d) Determine the visual magnitudes m_V (in mag) of the stars 1 to 3, as well as that of the binary 4.
 - e) One pixel of the CCD camera which was used to obtain the image has physical size $9 \mu\text{m} \times 9 \mu\text{m}$. Find the angular size θ (in arcsec) that corresponds to one cell of the table in Figure 22.
 - f) Determine the surface brightness S (in mag arcsec $^{-1}$) of the sky around the field shown in Figure 21, as it was seen from the Observatory in Valašské Meziříčí. Compare with the surface brightness of the sky on a moonless night in the center of Prague ($S_{\text{Prague}} \simeq 18.5$ mag arcsec $^{-1}$), on the peak of Lysá hora ($S_{\text{LH}} \simeq 21.5$ mag arcsec $^{-1}$) and at the Astronomical Institute in Ondřejov ($S_{\text{Ondřejov}} \simeq 21.0$ mag arcsec $^{-1}$).
- [a) (210 ± 1) ADU; b) -3.35 mag, -4.16 mag, -2.17 mag, -5.42 mag, -5.11 mag;
 c) -15.96 mag; d) 11.43 mag, 13.42 mag, 10.17 mag, 10.49 mag; e) $9.9''$;
 f) 20.77 mag arcsec $^{-1}$]

100 years of the projection planetarium

The humankind has always been fascinated by the starry sky and the mysteries of the universe. But it is only since 21 October 1923, when ZEISS presented the very first planetarium projector and „brought the heavens down to earth“.

Today, 100 years after its invention, planetarium activities are still linked to science, technology and education. Modern digital planetariums have evolved into spherical immersive projection devices that simulate space travel, popularise science and spread culture. There are more than 4,000 „bricks and mortar“ planetariums and tens of thousands of mobile planetariums worldwide. Many of them are also used to prepare students for various astronomy competitions.

In the **Czech Republic**, two such facilities host the national finals of the Astronomy Olympiad in various categories: the Unisphere at the Institute of Physics of the Silesian University in Opava, and Planetarium Prague (Planetum).

The Unisphere is a digital planetarium and the first spherical projection at a Czech university, built as a teaching tool and a studio for students creating advanced audiovisual and fulldome programmes designed for science outreach. It is located in the building of the Institute of Physics of the Silesian University in Opava and was completed in 2019. It consists of a suspended seamless projection dome with a diameter of 8 m and a tiered auditorium with a capacity of 50 seats. It uses the Digistar 7 system, which enables creating original shows, spherical projection of downloaded shows, even stereoscopic (3D) ones.

Planetarium Prague is located next to the Exhibition Grounds in Prague and is partially funded by the city. Its building was designed by the architect Jaroslav Fragner and opened to the public on 20 November 1960. The dome diameter is 23.5 m and it used to be equipped with both the classical optomechanical planetarium by Zeiss and a modern digital projection. It is now undergoing a major upgrade, and in 2024, it will be one of the first planetariums in the world to use the LED panel technology on a spherical surface.

It is somewhat paradoxical that, after 100 years of projection planetariums, there should be a technological breakthrough where the concept of projection is abandoned and the spherical surface is a giant screen with tens of millions of LED pixels. Until now, the cost of these installations has been astronomical, but their benefits are undeniable. The next round of competitions at the IOAA may be solving problems under the sky with LEDs!

ISBN 978-80-907341-5-9

