

Top View

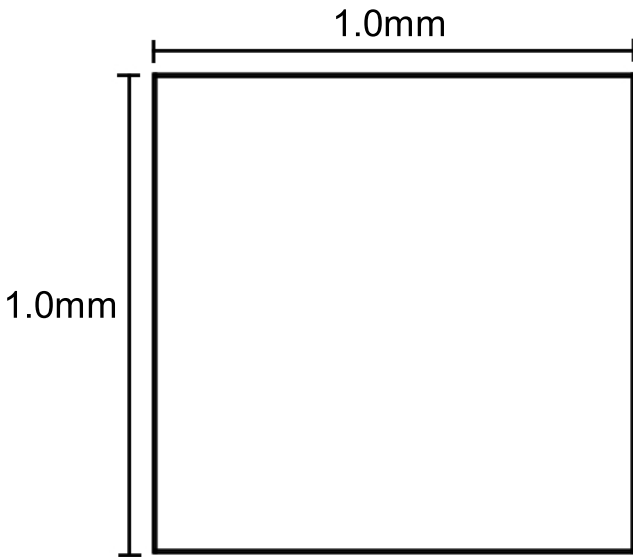

Side View

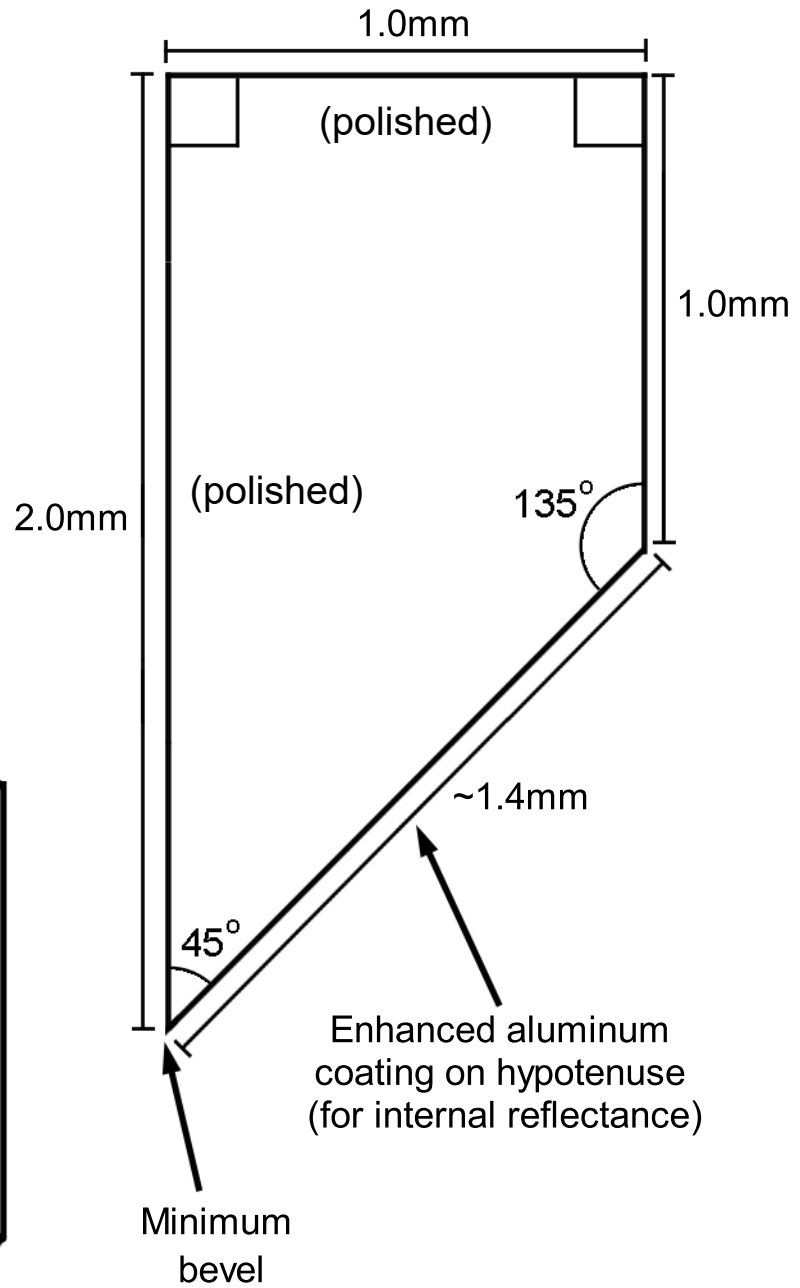

3D View

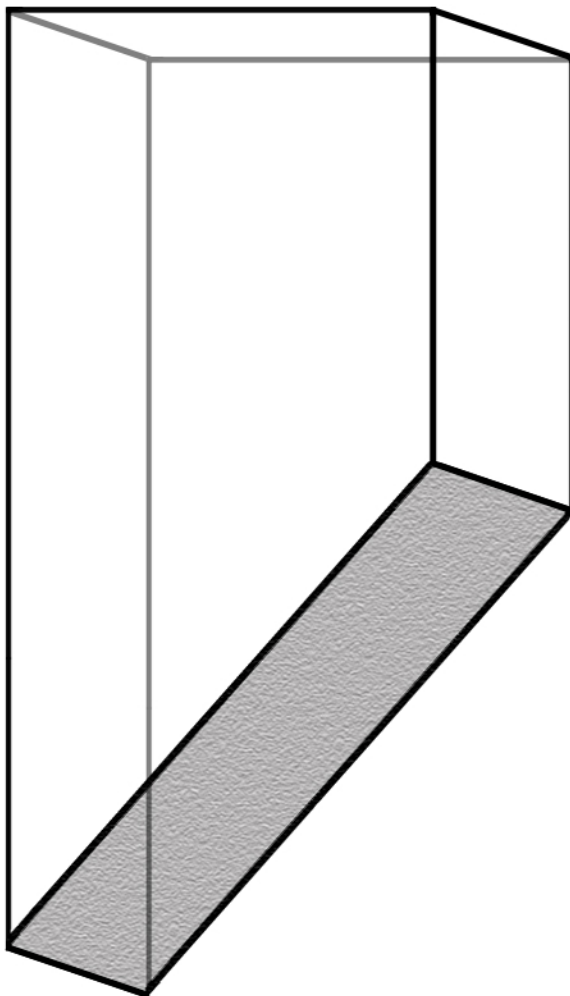

Notes:

1. Material: H-K9L
2. Flatness: L/4
3. SQ: 60/40
4. Dim Tol: +/-0.05mm
5. Angle Tol: +/- 1 arcmin
6. Coating: For internal reflectance