

Solar/Electromagnetic Energy Harvesting and Wireless Power Transmission

Kyriaki Niotaki, *Student Member, IEEE*, Ana Collado, *Senior Member, IEEE*,
Apostolos Georgiadis, *Senior Member, IEEE*, Sangkil Kim, *Student Member, IEEE*,
Manos M. Tentzeris, *Fellow, IEEE*

Abstract— This manuscript presents a review of existing works and solutions in the field of solar/electromagnetic energy harvesting and wireless power transmission. More specifically the paper covers: solar/electromagnetic harvesters where solar antenna structures are used to obtain a compact implementation, DC combining circuits necessary to combine the outputs of the solar and the electromagnetic harvesters and, efficient solar to EM converters that can be used to synthesized autonomous wireless power transmission RF signal generators. Finally, novel topologies to minimize the sensitivity of rectifier circuits to variations in the received RF power levels are presented.

Index Terms— energy harvesting, rectifier, solar energy, resistance compression network, rectenna.

I. INTRODUCTION

IN the recent years there has been an increased interest in providing autonomy and self-sustainability to devices and sensors towards implementing concepts such as the Internet of Things (IoT), Smart Cities and Smart Environments in general [1]-[3]. Energy harvesting technologies appear as an alternative to provide this autonomy, collecting energy from different types of sources such as solar, thermal, kinetic or electromagnetic (EM) and converting it to DC power. However the amount of available energy from these sources is variable and sometimes unpredictable which conditions the conversion efficiency that can be obtained and the amount of DC power that is available. In this context the use of hybrid energy harvesters, which can collect energy from more than one energy source, seems a manner to overcome this limitation. Several works have considered the use of hybrid energy harvesters to obtain the required DC power to operate certain platforms or devices [4]-[8], such as solar/EM [4],[5], vibration/solar [6], solar/thermal [7] and solar/thermal/vibration [8] hybrid harvesters.

This work was supported by the Spanish Ministry of Economy and Competitiveness project TEC2012-39143, and the COST Action IC1301 ‘Wireless Power Transmission for Sustainable Electronics (WIPE)’.

K. Niotaki, A. Collado and A. Georgiadis are with the Centre Tecnologic de Telecomunicacions de Catalunya (CTTC), 08860 Castelldefels, Spain (e-mail: acollado@cttc.es).

S. Kim and M. M. Tentzeris are with the School of Electrical and Computer Engineering, Georgia Institute of Technology, Atlanta, GA 30332-250 USA. (e-mail: ksangkil3@gatech.edu).

In the case of EM energy harvesting another measure that can be taken into account to overcome the problem of unpredictable power levels that may affect RF-DC conversion efficiency is to use topologies in the rectifier circuits that minimize the effect of these variations. Rectifier circuits are usually designed to operate for specific conditions in terms of input power level and loading conditions. Thus, a deviation from the nominal operation results in degraded performance.

Although, the rectifier is designed to operate efficiently for a specific amount of harvested power, the available power in the environment is variable. Such a change results in impedance variation due to the nonlinear nature of the rectifying devices. The same applies for the load variations. As rectifiers are fundamental circuits for energy harvesting applications, their reduced sensitivity on the system operating conditions will result in an improved performance of the total harvester. In order to alleviate the problem of impedance changes, special consideration should be paid for the design of the matching network placed between the RF source and the diode.

A solution to reduce the load sensitivity of the rectifier has been introduced in [9] where resistance compression networks (RCNs) are used. These RCNs are used as matching network in rectifier circuits, placed between the input signal and the rectifying device. So far, resistance compression networks that operate at a single frequency have been proposed.

Since ambient energy is available in many frequency bands, the design of multiband and broadband rectifiers is of great importance. Thus, the design of resistance compression networks operating at different frequencies is a major challenge. Recently, the concept of dual-band resistance compression networks has been introduced [10].

Finally, the use of wireless power transmission can also be considered in order to ensure enough DC power [11]-[19]. An autonomous manner to achieve RF power transmission is the use of solar to EM converters that take available solar energy and use it to generate RF signals to be used to power up sensors or devices that are equipped with an EM energy harvester or rectifier circuit [17]-[19].

In this paper, all of these topics will be covered. Section II shows several examples of solar/EM energy harvesters, focusing on achieving a compact implementation by using solar antennas, and also the design of the DC combining circuits necessary in any hybrid solar/EM harvester. Section

III focuses on solar to EM energy converters for wireless power transmission. Finally, Section IV covers the topic of sensitivity reduction in rectifier circuits towards minimizing the effect that variations in the available RF power or in the output load may have on the RF-DC conversion efficiency.

II. HYBRID SOLAR/EM ENERGY HARVESTING

EM harvesters are designed to achieve a certain RF to DC conversion efficiency for a range of RF input power levels. However, the levels of available EM energy in the environment are variable and sometimes unpredictable which causes the RF to DC conversion efficiency to degrade and consequently the obtained DC power is insufficient.

An alternative to overcome this problem is the use of hybrid energy harvesters where the energy from different energy sources is collected. Then the DC outputs of the different harvesters are combined to provide the necessary DC power. An example of this is the hybrid solar/EM harvester [4],[5] where the energy is collected both from solar energy by means of solar panels and from EM sources by means of rectenna elements. In order to obtain a compact design of these types of hybrid solar/EM harvesters it is of key importance the integration of the solar cells together with the EM harvester antenna structure.

A. Solar antennas

In order to obtain a compact integration of the hybrid solar/EM harvester it is possible to integrate the solar panels on top of the radiating structure that will be used in the EM harvester. It has been previously shown [20]-[26] that it is possible to minimize the effect that the solar cells have on the antenna performance by properly selecting the position of the solar cells within the antenna surface. If the solar panels are placed in areas where the field distribution are weaker the effect they have can be minimized. This concept appeared first in the field of satellites as a manner to reduce the size of the satellite systems by integrating together the antenna arrays and the solar panels [20],[21]. In [21] an X-band solar reflectarray formed by cross-dipole elements was developed where the radiating elements were placed on top of the solar panels. A 2.2 GHz solar patch antenna was proposed by [20] where the solar cells were placed avoiding the edge of the patch radiating element to minimize the effect of the solar cell on the antenna performance. A wearable aperture coupled shorted patch solar antenna operating in the 900 MHz ISM band was presented in [22] where the DC connection of the solar cells were placed on the side of the antenna where the patch was shorted to minimize the effect these connections may have on the antenna performance. In [23] both linearly and circularly polarized solar slot antennas were presented showing that the antenna performance is preserved by properly placing the solar cells avoiding the areas surrounding the slot where the

field distributions are stronger. In [24] two UWB solar antennas operating in the 3.1GHz to 10.6 GHz frequency band were designed to provide autonomy to a system of wireless sensor nodes. Also in [25] a 3D solar omnidirectional antenna structure based on radiating slots operating at 2.4 GHz was presented where the solar cells are placed to avoid the area occupied by the slots.

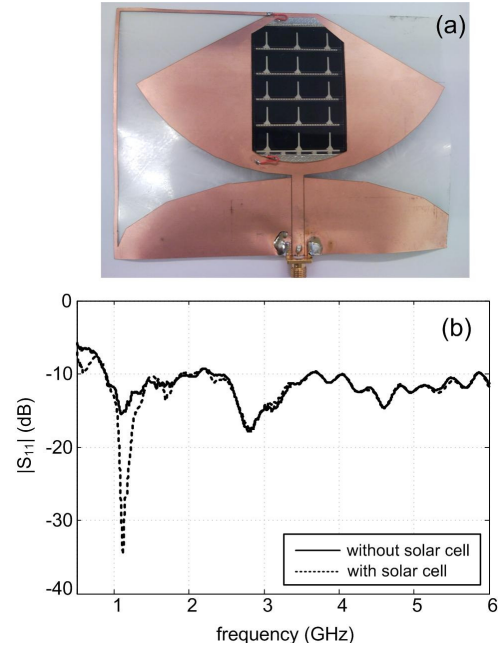

Fig. 1 (a) UWB printed monopole solar antenna, (b) Input matching of the UWB solar antenna. After [4],[5].

A broadband solar printed monopole antenna operating from 800 MHz to 6 GHz (Fig. 1) was presented in [4],[5] to be used in a hybrid solar/EM energy harvester (see Section II.B). The radiating structure was fabricated using flexible polyethylene terephthalate (PET) substrate and the feed was implemented in coplanar waveguide (CPW) technology. The selected solar cells were flexible thin film amorphous silicon (a-Si) solar cells (Power Film SP3-37) with open circuit voltage of $V_{OC} = 4.1$ V and short circuit current of $I_{SC} = 28$ mA, when illuminated by the standard global solar irradiance spectrum corresponding to air mass 1.5 (AM1.5G) also known as 1 sun = 100 mW/cm^2 . Their location on the antenna surface was selected by means of electromagnetic simulations in order to select the areas of the antenna where the field distributions were weaker targeting to minimize the effect of the solar cell on the antenna performance. Fig. 1b shows the measured results of the fabricated antenna structure of Fig.1a showing that the input matching of the antenna is not affected by the solar cell presence. The gain of the antenna is only slightly affected by the presence of the solar cell, and the main effect is an increase in the cross-polarization levels [4].

The work in [26] showed a substrate integrated waveguide (SIW) solar cavity-backed slot antenna (Fig.2) that was used as part of a hybrid solar/EM harvester to power up a sensor platform. In this work a-Si solar cells are placed avoiding

covering the area surrounding the slot in order to reduce the effect on the antenna performance.

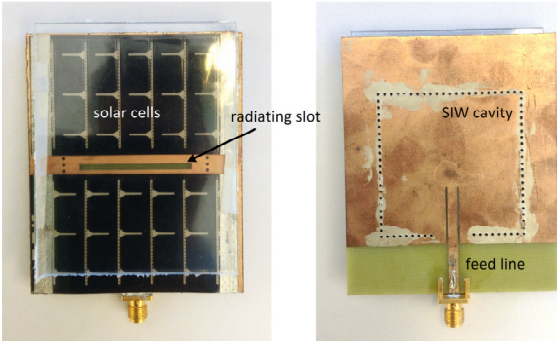

Fig. 2 SIW solar cavity-backed slot antenna (after [26]).

B. DC Combining Circuits for Hybrid Harvesters

One of the key components towards designing and implementing hybrid energy harvesters is the DC combining circuits that are required to add up the obtained DC outputs from the different harvesting units.

Several works [27]-[29] have shown different alternatives to combine the DC outputs focusing mainly in the combination of rectenna DC outputs. In [27] a reconfigurable DC combining circuit is presented that aims to combine either in series or parallel the DC outputs of rectenna array elements. This work also shows the importance of considering the variation in the optimum output load to be used attending to the DC combining circuit configuration and how this can affect the rectification efficiency. Also in [28],[29], the authors demonstrated the degradation that the combined DC outputs can suffer when connecting unequal rectenna elements and how by properly selecting the connection scheme this degradation can be minimized.

In [26] a DC combining circuit that combines the DC outputs in a hybrid solar/EM energy harvester is presented. This DC combining circuit integrates both a 2.45GHz RF-DC converter necessary for the EM harvester and the additional circuitry required to combine the output of the solar cells and the output of the EM harvester. The schematic of the proposed DC combining circuit is shown in Fig.3.

Depending on the solar irradiance values the loading effect that the solar cells have on the DC combining circuit varies. This variation produces changes in the input matching of the complete DC combining circuit. As the DC combining circuit includes the RF to DC converter for the EM harvester these variations in the input matching are undesirable as they affect the RF-DC conversion efficiency that can be obtained. The combining circuit is designed aiming at minimizing the variations in the input matching under changing conditions of irradiance, by using two parallel rectification branches.

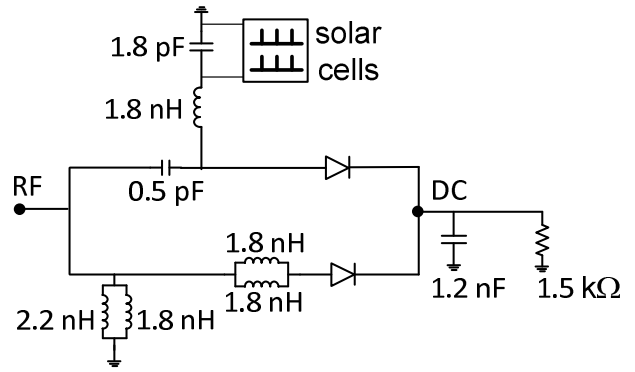

Fig. 3 Schematic of the DC combining circuit after [26].

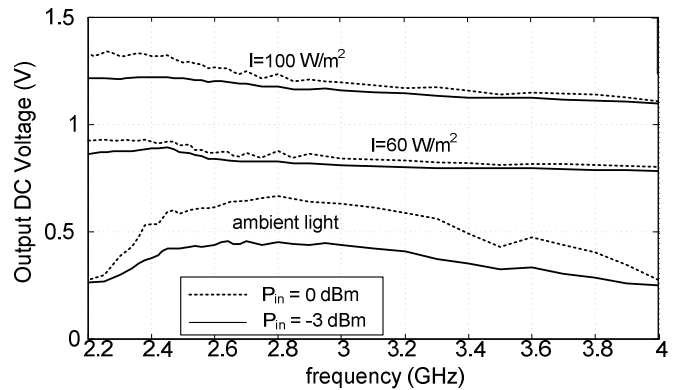

Fig.4 Output DC voltage measured when operating the DC combining circuit simultaneously with an RF input signal and with the solar cells illuminated.

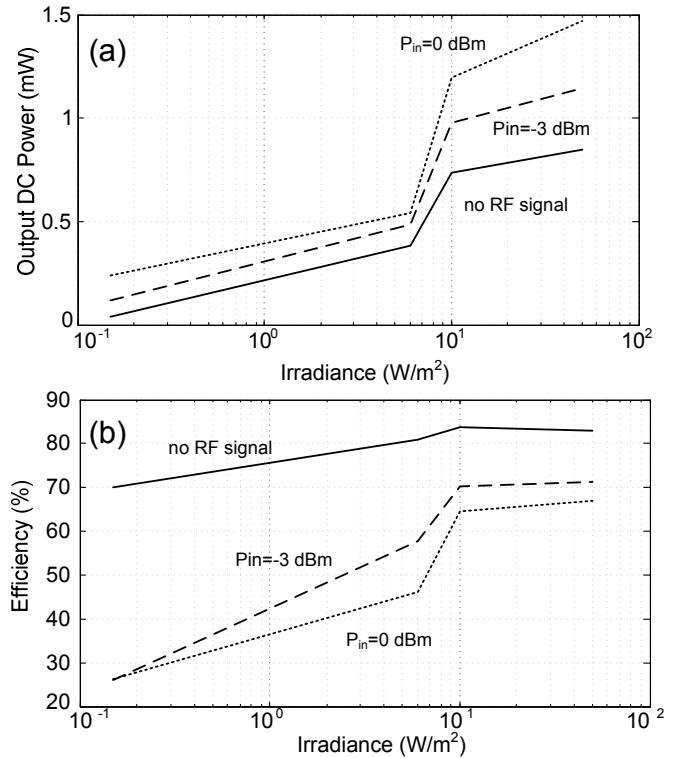

Fig. 5 Measured DC combining circuit performance versus irradiance and for different RF input power levels (2.45 GHz). (a) Output DC power, (b) Efficiency calculated using (1).

Fig.4 shows the measured DC output voltage of the combining circuit for different irradiance values and for two different RF input power levels (0dBm and -3dBm). For ambient light conditions (low irradiance values) the effect of increasing the RF input power level can be clearly seen and the contribution of the EM harvester to the DC output is comparable to that of the solar cells. However in the case of higher irradiance conditions the main contribution to the DC voltage comes from the solar cells and the increase in the RF input power level does not significantly reflect in the obtained DC voltage. These results show that for low RF input power levels the use of the hybrid solar/EM is more suitable under low irradiance conditions, while if the irradiance is high the hybrid harvester could just be operated as a solar harvester.

C. Hybrid Solar/EM Energy Harvesters

The efficiency of the hybrid solar/EM harvester in [26] when operating simultaneously with an RF input signal and considering that the solar cells are illuminated is evaluated using the following expression:

$$\eta = 100 \frac{P_{DC}}{(P_{RF} + P_{solar})} \quad (1)$$

Where P_{DC} is the output DC power of the DC combining circuit, P_{RF} refers to the RF input power level and P_{solar} is the DC power obtained from the solar cells. This P_{solar} is calculated by measuring the voltage drop at the solar cell terminal and the current passing through it considering different irradiance conditions and different levels of RF input power.

In Fig.5 the measured combined DC output power and efficiency for different operation conditions in terms of irradiance and RF input power levels (2.45 GHz) are presented. As expected when both solar and EM energy are present it is possible to obtain higher values of DC output power. However, the DC combining circuit efficiency is better for higher values of irradiance and no RF signal present. As also shown in Fig.4, the harvester should operate in the hybrid solar/EM mode only when there is not enough light and there is a demand of DC power. However if there is enough light it is more efficient to only operate in the solar harvester mode.

Another example of a solar/EM harvester design was presented in [4],[5]. The proposed harvester (Fig.6) is a dual-band hybrid solar/EM energy harvester that uses the solar antenna in Fig.1 and that harvests RF signals in the GSM-850 and GSM-1900 frequency bands. The complete harvester is implemented in PET substrate, which together with the flexible a-Si solar cell allows achieving a conformal harvesting structure. The harvester is designed to maximize the RF to DC conversion efficiency in the two frequency bands (850MHz and 1850 MHz) obtaining efficiency values around 15% for -20dBm input power levels.

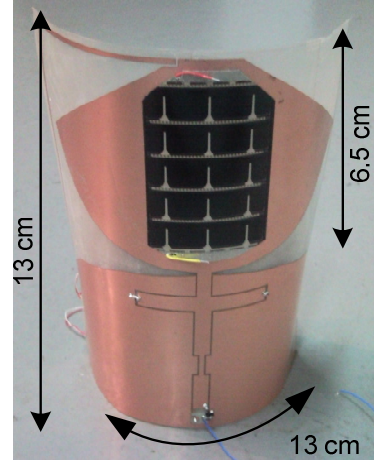

Fig.6 Dual-band solar/EM energy harvester (after [4],[5]).

The performance of the EM harvester is evaluated for different illumination conditions of the solar cells. Results in terms of obtained output DC voltage from the EM harvester for irradiance values of approximately 1000 W/m^2 ($1000 \text{ W/m}^2 = 100 \text{ mW/cm}^2 = 1 \text{ sun equivalent value}$) and 150 W/m^2 are shown in Fig.7. The measurements were obtained for an outdoor setup where the harvester was under direct sunlight (1000 W/m^2) and in the shade (150 W/m^2). The values of the irradiance were measured using a solar radiation meter. The solar cell open circuit voltage and short circuit current for this two values of irradiance were $V_{oc} = 4.06 \text{ V} / I_{sc} = 23.2 \text{ mA}$ and $V_{oc} = 3.90 \text{ V} / I_{sc} = 4.3 \text{ mA}$ respectively.

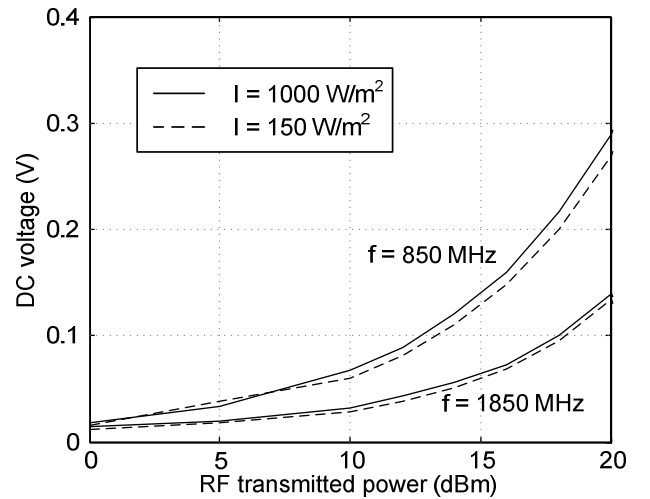

Fig.7 Obtained DC voltage from the EM harvester when the solar cells are illuminated.

III. SOLAR TO EM ENERGY CONVERSION

As it was already mentioned, solar energy can provide higher levels of harvested DC power if compared to EM sources. This fact can be used to obtain additional sources of

EM signals when there is availability of solar light but limited EM signals in the environment.

The idea of solar to EM energy conversion has been broadly covered in the field of solar power satellites [11]-[16] aiming at collecting solar energy by means of large solar panels integrated on satellites in orbit and then convert it to EM energy that can then be radiated to earth or to other satellites where it can be converted back to DC.

In a smaller scale it is possible to use solar to EM converters to generate EM signals that can be used as RF generators for wireless power transmission applications. Solar to EM converters take solar energy by means of solar panels and use the obtained DC power to generate EM signals by powering up certain frequency generation circuits such as oscillators.

In [17] a solar to EM converter based on a class-E oscillator was presented (Fig.8). Amorphous silicon (a-Si) solar cells (Power Film SP3-37) were used to capture the solar energy and provide the necessary DC power to start-up a high efficiency 905 MHz class-E oscillator. The generated 905 MHz signal was then transmitted by means of a monopole antenna.

The converter design was optimized for low illumination conditions by connecting three pieces of the SP-37 solar cells in parallel to maximize the generated currents. The created solar cell module has an open circuit voltage of 1.7V and short circuit current of 84mA under 1 sun irradiance. The measured DC-RF efficiency was of approximately 43% when the oscillator was biased at $V_c = 1.5$ V and $I_c = 3.2$ mA.

The DC-RF efficiency was calculated using:

$$\eta_{DC-RF} = 100 \cdot \frac{P_{RF}}{P_{DC}} \quad (2)$$

Where P_{RF} is the RF output power of the oscillator circuit and $P_{DC} = V_c \cdot I_c$.

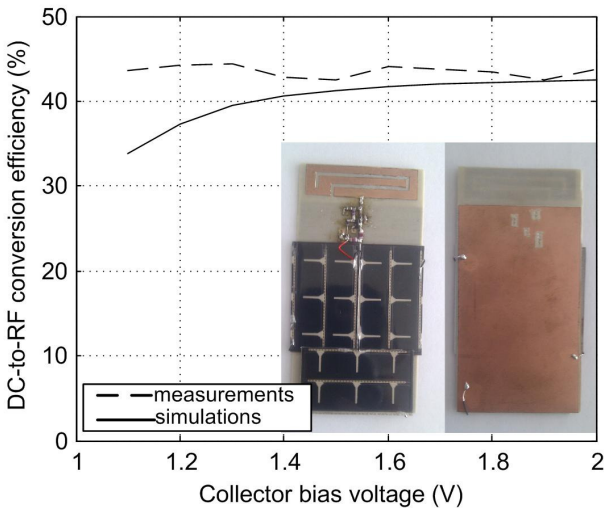

Fig.8 Solar to EM converter at 905 MHz after [17].

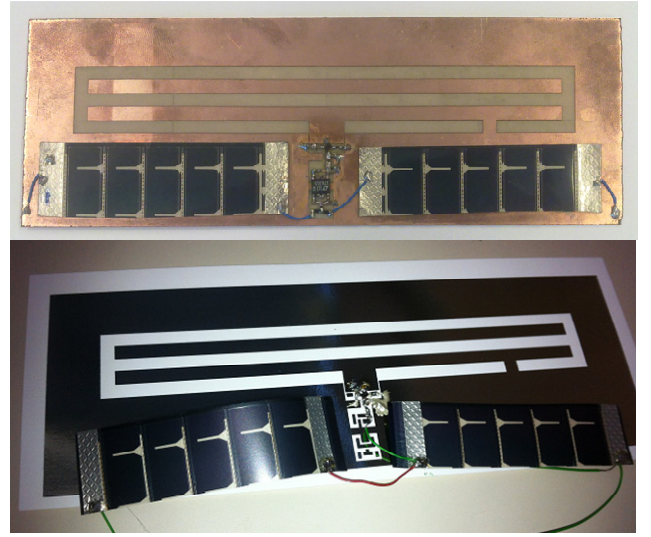

Fig.9 CPW folded slot solar to EM converter (a) PET implementation (b) Inkjet-printed on photopaper implementation (after [18],[19]).

In [18],[19] a solar to EM converter was presented (Fig.9), where the radiating element is a coplanar waveguide fed triple-slot structure with a shorting strip that allows for size reduction.

The solar energy is collected by means of two halves of an a-Si solar panel, each half having approximately 4 V of open circuit voltage and 13 mA of short circuit current. The solar cells are placed on the ground plane avoiding the sensitive antenna areas to avoid affecting its performance.

The obtained DC voltage from the solar cells is used to power up an oscillator circuit in the 900 MHz frequency band that requires 1.5V of drain voltage with 6 mA current to operate. A Linear LT1763-1.5 regulator is used to deliver a stable supply voltage to the oscillating circuitry. The regulator takes at its input a minimum voltage of 1.8 V, providing at its output a fixed 1.5 V voltage and can provide up to 500 mA current with 300 mV dropout voltage. The solar cells are connected to the regulator input through two Schottky diodes (Skyworks SMS7630-079LF) in order to isolate them and minimize the effect of imbalances between them in terms of provided voltage.

Two versions of the solar to EM converter were proposed in [18],[19], where one of them was implemented in PET substrate by using a conventional milling fabrication process and the second one was inkjet printed on paper substrate.

IV. RESISTANCE COMPRESSION NETWORKS

In [9], rectifier circuits that achieve a reduced sensitivity to load and input power variations have been introduced. These circuits are based on the so called resistance compression networks (RCN) [9]. A resistance compression network is formed by two branches that exhibit opposite phase response (ϕ and $-\phi$ respectively) at the operating frequency (Fig. 10a).

Under these phase conditions, the input impedance of the RCN (Z_{in}) suffers small variations under large variations of the real load values (R_L).

In rectifier circuits, changes in the output load or changes in the input power produce changes in the input matching of the rectifying device (usually a Schottky diode). These changes in the input matching can produce degradation on the circuit performance. RCN can be used as the matching network in rectifier circuits. If properly designed these networks are able to achieve resistance compression and additionally impedance transformation.

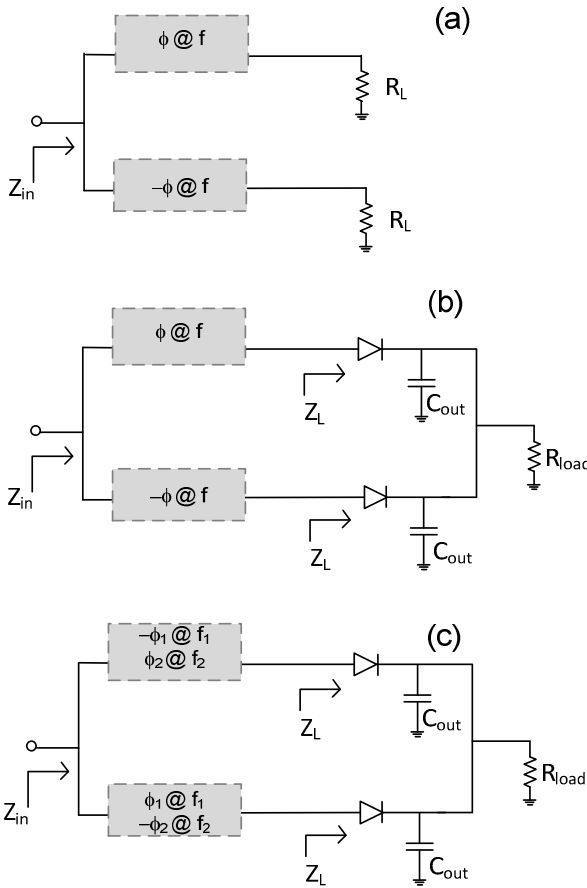

Fig. 10. RCN topologies (a) single frequency RCN with real load, (b) single frequency RCN based rectifier, (c) dual frequency RCN based rectifier.

So far, different implementations of resistance compression networks according to the application scenario and/or the desired frequency have been reported [9],[30].

The concept of resistance compression has already been applied to the design of electronic circuits operating at low RF and microwave frequencies. In [9], a RCN is applied for the design of a 100 MHz DC-DC converter demonstrating the reduced load sensitivity of resonant DC-DC converters. A high efficiency resonant DC-DC converter based on a resistance compression network is also presented in [31]. The isolation resistor of a matched combiner has been replaced by a rectifier based on RCNs in [32]. Also, the resistance-compressed rectifier can contribute to the high efficiency and

linearity of an outphasing energy recovery system as shown in [33] where a transmission line based impedance compression network (ICN) is presented. The impedance compression network is applied for the design of a harmonically terminated rectifier operating at 4.6 GHz [33]. The circuit is implemented with and without impedance compression network in order to demonstrate the improved performance obtained with ICN in an outphasing system.

A. Dual Band Resistance Compression Networks

As stated before, the operating principle of a resistance compression network is that an equal and opposite phase response (ϕ and $-\phi$) is present in each of the branches that form a RCN at a certain operating frequency. This way large variations in the load R_L do not produce large variations in the input matching (Z_{in}) of the circuit [9], due to the compression performed by the RCN (Fig.10a). The desired compression is usually achieved using one capacitor (C) and one inductor (L) for each of the branches. When operating at the resonant frequency ($\omega = \sqrt{LC}$), the input impedance of the network (Z_{in}) varies a small amount for large variation of R_L [9]. In the case of a rectifier circuits R_L is substituted by a Z_L that corresponds to the input impedance of the rectifying device (Fig.10b). Additionally, if dual band resistance compression is desired, the structure shown in Fig. 10(c) can be applied [10]. The goal for the design of the dual-band resistance compression networks is that an equal and opposite phase response ($-\phi_1$ and ϕ_1 / ϕ_2 and $-\phi_2$) is met at the two frequencies f_1 and f_2 . A dual-band network that fulfills the previously mentioned requirements is the LC structure shown in Fig.11 [34].

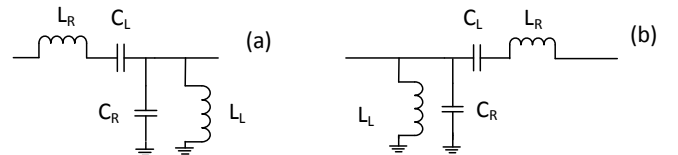

Fig. 11. LC networks that exhibit equal but opposite phase response at the two operating frequencies: a) conventional topology and b) rearranged network

TABLE I
PHASE CHARACTERISTICS OF THE CRLH UNIT CELLS SHOWN IN FIG. 11

Operating Frequency	LC network in Fig. 11(a).	LC network in Fig. 11(b).
f_1	$-\phi_1$	ϕ_1
f_2	ϕ_2	$-\phi_2$

The LC network (Fig. 11(a)) and the rearranged LC network (Fig. 11(b)) exhibit a dual-band frequency response at the frequencies f_1 and f_2 , where $f_1 < f_2$. When the network in Fig.11(a) operates at f_1 , the series inductance (L_R) and shunt

capacitance (C_R) tend to be short and open, respectively. Likewise, when operating at the high frequency f_2 the series capacitance (C_L) and shunt inductance (L_L) tend to be short and open, respectively.

The most important feature of this structure is the phase response that is achieved at the desired frequencies. In particular, the LC network in Fig.11 (a) has a negative phase ($-\phi_1$) for the low operating frequency (f_1) and a positive phase response (ϕ_2) for f_2 . The rearranged unit cell of Fig. 11(b) depicts equal but opposite phase responses at the two frequencies. Table I summarizes the phase response of the unit cells.

Taking advantage of the phase properties of the unit cells, a dual-band resistance compression network can be designed at f_1 and f_2 . As an example application, a dual-band resistance-compressed rectifier for energy harvesting applications is designed and evaluated [10]. Two unit cells are used as the impedance matching network that compresses the resistance variation between the diode of the rectifier and the input signal. The selected frequencies for this application example are 915 MHz and 2.45 GHz.

B. Performance Results

A RCN based dual band (915 MHz/2.45 GHz) rectifier is designed and experimentally validated in [10]. Fig. 12a shows the schematic of the designed rectifier with a two diode topology. The SMS7630 Schottky diode is used for the current design. Two identical LC networks (Fig. 11(a)) are used at the upper branch and two identical rearranged LC networks (Fig. 11(b)) are placed at the lower branch in order to exhibit the appropriate phase response at f_1 and f_2 . For this design two LC sections such as the ones in Fig.11 have been used in each of the branches in order to provide more flexibility during the design phase. The rectifier circuit is designed to be matched to a 50 Ω source. The circuit is designed using Harmonic balance (HB) and large signal scattering parameters (LSSP) analysis in Agilent ADS software. Optimization goals are imposed in order to achieve the impedance matching and to maximize the RF-DC conversion efficiency of the circuit.

The optimization process resulted in the following component values for each LC unit cell: $L_R=8.7$ nH, $C_L=27$ pF, $C_R=0.8$ pF and $L_L=100$ nH. The shunt capacitance of 0.8 pF is implemented as a radial stub. The selected chip inductors and capacitors are from Coilcraft and Murata, respectively. The selected optimum output load is 1K Ω . The prototype is fabricated in Arlon 25N substrate (30 mil) with a relative permittivity of 3.38 and loss tangent of 0.0025.

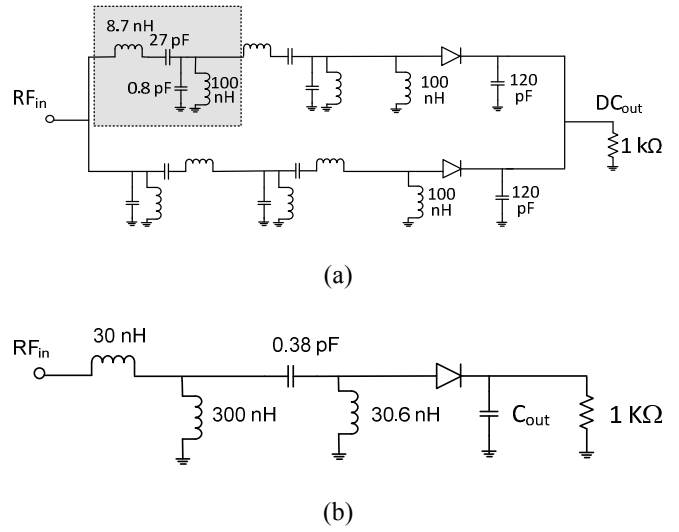

Fig. 12. Schematic of the two designed rectifiers (a) RCN based dual-band rectifier (b) Envelope detector rectifier.

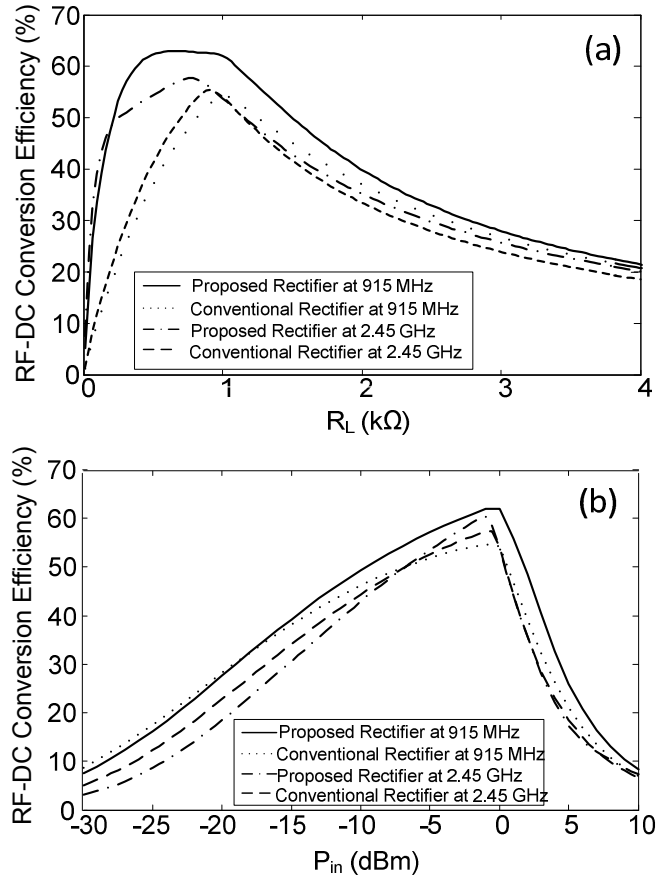

Fig. 13. Simulated RF-DC conversion efficiency of the 915 MHz/2.45 GHz RCN based rectifier and the 915 MHz/2.45 GHz envelope detector rectifier. (a) RF-DC conversion efficiency versus output load ($P_{in}=0$ dBm) (b) RF-DC conversion efficiency versus input power ($R_L=1$ KOhm).

The performance of the designed RCN based rectifier is compared to that of a conventional dual-band rectifier based on an envelope detector topology (Fig.12) and using the same Schottky diode SMS7630. Both circuits are optimized for maximum RF-DC conversion efficiency at 915 MHz and 2.45 GHz. A comparison of the proposed rectifier with the conventional approach is presented in Fig. 13. It can be observed an efficiency improvement in the RCN based rectifier as well as less variation in the efficiency versus load and input power variations.

The final implemented prototype of the RCN based rectifier is shown in Fig.14. The simulated and measured RF-DC conversion efficiency of this dual-band rectifier for an input power of -15 dBm and an output load of 1 K Ω is illustrated in Fig. 15, demonstrating a good match between simulation and measurements. Fig.16 shows the RF-DC conversion efficiency and the output DC voltage of the implemented circuit versus input power and versus output load variations, at the two frequencies with peak measured efficiencies in Fig.15, to demonstrate that the RCN allows reducing the effect of these two parameters on the circuit performance. In Fig.16 the simulations for the RF-DC conversion efficiency versus input power are not included due to inaccuracies in the diode model for high input power levels.

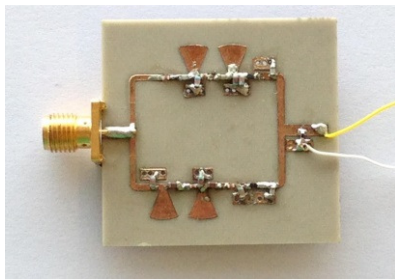

Fig. 14. Fabricated prototype of the RCN based 915MHz/2.45GHz dual-band rectifier (after [10]).

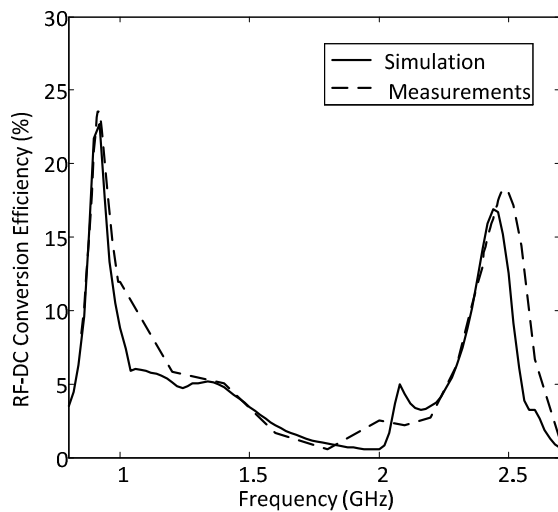

Fig. 15. Simulated and measured RF-DC conversion efficiency versus frequency for an input power of -15 dBm and 1K Ω output load.

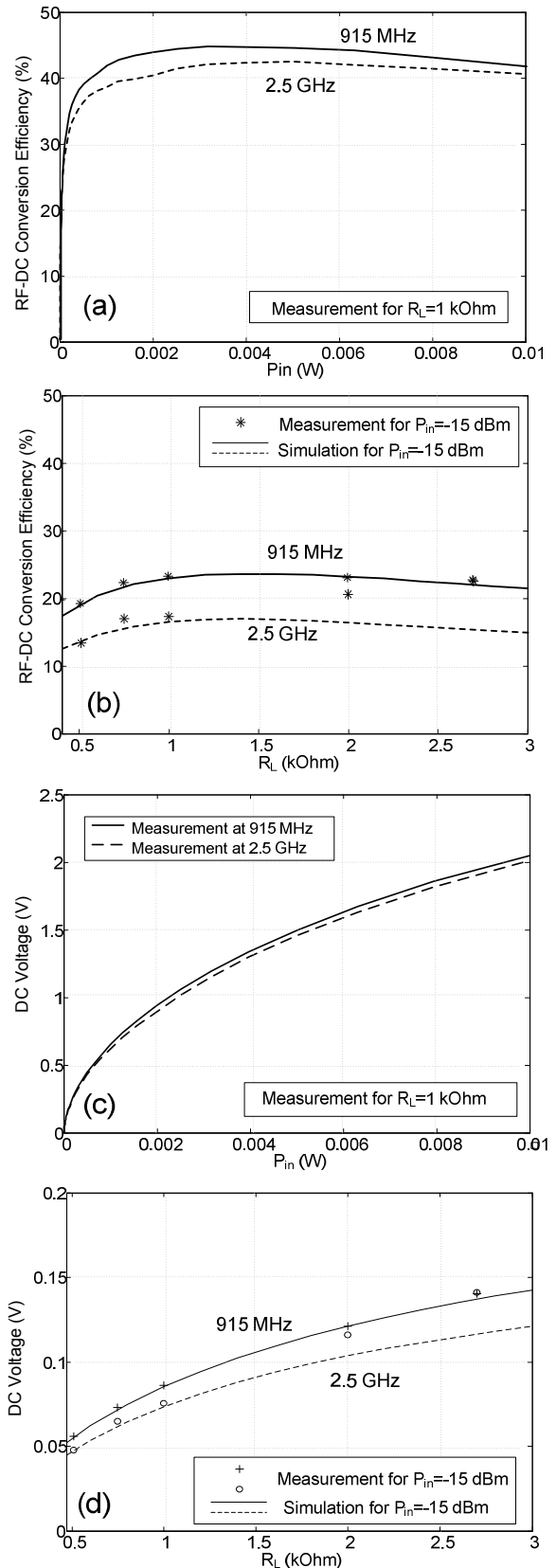

Fig. 16 Simulated and measured results for the RCN based dual-band rectifier (a) RF-DC conversion efficiency versus input power (b) RF-DC conversion efficiency versus output load (c) Output DC voltage versus input power (d) Output DC voltage versus output load.

V. CONCLUSION

This paper covers the topic of hybrid solar/EM energy harvesting, where both solar and electromagnetic energy sources are considered, for its use in environments or applications where the levels of available energy are variable or unpredictable. As a manner to create compact solar/EM harvesters the use of solar antennas where the solar panels share the same area as the radiating element is of key importance. Several examples of solar antennas and solar/EM harvesters are presented in this paper. Examples of the required DC combining circuits in hybrid energy harvesters to combine the DC outputs for the different harvesting units are also discussed.

Additionally, solar to EM converters where solar energy is used to power up frequency generation circuits that synthesize EM signals to be used as wireless power transmitters are covered in this paper, as well as the use of rectifier topologies that minimize their sensitivity to input power and load variations based on the use of RCN.

REFERENCES

- [1] W.C. Brown, "The history of power transmission by radio waves", IEEE Trans. On Microw. Theory and Techn., vol. 32, no. 9, pp. 1230-1242, Sep. 1984.
- [2] J. A. Hagerty, F. B. Helmbrecht, W. H. McCalpin, R. Zane, and Z.B. Popovic, "Recycling ambient microwave energy with broadband rectenna arrays," IEEE Trans. Microw. Theory Tech., vol. 52, no. 3, pp. 1014-1024, Mar. 2004.
- [3] N. Bui, A. Georgiadis, M. Miozzo, M. Rossi, X. Vilajosana, "SWAP Project: Beyond the State of the Art on Harvested Energy-Powered Wireless Sensors Platform Design," Mobile Adhoc and Sensor Systems (MASS), 2011 IEEE 8th International Conference on , vol., no., pp.837,842, 17-22 Oct. 2011.
- [4] A. Georgiadis, A. Collado, S. Via and C. Meneses, "Flexible Hybrid Solar/EM Energy Harvester for Autonomous Sensors", in Proc. 2011 IEEE MTT-S Intl. Microwave Symposium (IMS), Baltimore, US, June 5-10, 2011.
- [5] A. Collado, A. Georgiadis, "Conformal Hybrid Solar and Electromagnetic (EM) Energy Harvesting Rectenna," *Circuits and Systems I: Regular Papers, IEEE Transactions on* , vol.60, no.8, pp.2225,2234, Aug. 2013
- [6] Y.K. Tan, S.K. Panda, "Energy Harvesting From Hybrid Indoor Ambient Light and Thermal Energy Sources for Enhanced Performance of Wireless Sensor Nodes," Industrial Electronics, IEEE Transactions on , vol.58, no.9, pp.4424,4435, Sept. 2011.
- [7] J. Colomer, J. Brufau, P. Miribel, A. Saiz-Vela, M. Puig, J. Samitier, "Novel autonomous low power VLSI system powered by ambient mechanical vibrations and solar cells for portable applications in a 0.13 μ technology," Power Electronics Specialists Conference, 2007. PESC 2007. IEEE , vol., no., pp.2786,2791, 17-21 June 2007.
- [8] S. Bandyopadhyay, A.P. Chandrakasan, "Platform Architecture for Solar, Thermal, and Vibration Energy Combining With MPPT and Single Inductor," Solid-State Circuits, IEEE Journal of , vol.47, no.9, pp.2199,2215, Sept. 2012.
- [9] Han Yehui, O. Leitermann, D.A. Jackson, J.M. Rivas and D.J. Perreault, "Resistance Compression Networks for Radio-Frequency Power Conversion," IEEE Trans. Power Electron., vol. 22, no. 1, pp.41-53, Jan. 2007.
- [10] K. Niotaki, A. Georgiadis, A. Collado, "Dual-Band Rectifier Based on Resistance Compression Networks", in Proc. 2014 IEEE MTT-S Intl. Microwave Symposium (IMS), Tampa, US, June 1-6, 2014.
- [11] P.E. Glaser, "Power from the Sun, Science", No.162, 1968, pp.857-886
- [12] W.C. Brown, "Status of the microwave power transmission components for the solar power satellite," IEEE Trans. Microwave Theory Tech., vol. 29, pp. 1319-1327, Dec. 1981.
- [13] Solar Power Satellite patent. Patft.uspto.gov. Retrieved 4 June 2009.
- [14] H. Matsumoto, "Research on Solar Power Satellites and Microwave Power Transmission in Japan," IEEE microwave magazine, pp.36-45, 2002.
- [15] S. Sasaki, K. Tanaka and Advanced Mission Research Group, "Wireless Power Transmission Technologies for Solar Power Satellite", IMWS-IWPT2011 Proceedings, pp.3-6, 2011.
- [16] McSpadden, J.O.; Mankins, J.C.; , "Space solar power programs and microwave wireless power transmission technology," Microwave Magazine, IEEE , vol.3, no.4, pp. 46- 57, Dec 2002.
- [17] A. Georgiadis, A. Collado, "Solar powered Class-E active antenna oscillator for wireless power transmission," Radio and Wireless Symposium (RWS), 2013 IEEE , vol., no., pp.40,42, 20-23 Jan. 2013
- [18] F. Giuppi et. al., "A 927 MHz Solar Powered Active Antenna Oscillator Beacon Signal Generator," IEEE Topical Conference on Wireless Sensors and Sensor Networks (WiSNet2012), Santa Clara, USA, Jan. 15-19, 2012.
- [19] A. Georgiadis, A. Collado, S. Kim, H. Lee, M.M. Tentzeris, "UHF Solar Powered Active Oscillator Antenna on Low Cost Flexible Substrate for Application in Wireless Identification," in Proc 2012 IEEE MTT-S IMS, Montreal, 17-22 June 2012.
- [20] M. Tanaka, R. Suzuki, Y. Suzuki, K. Araki, "Microstrip antenna with solar cells for microsattellites," IEEE International Symposium on Antennas and Propagation (AP-S), vol. 2, pp. 786-789, 20-24 June 1994.
- [21] M. Zawadzki, J. Huang, "Integrated RF antenna and solar array for spacecraft application," in Phased Array Systems and Technology, 2000. Proceedings. 2000 IEEE International Conference on, Dana Point, CA, May 2000, pp. 239-242.
- [22] F. Declercq, A. Georgiadis, H. Rogier, "Wearable aperture-coupled shorted solar patch antenna for remote tracking and monitoring applications," in Proc. 5th European Conference on Antennas and Propagation (EUCAP), pp.2992-2996, Rome, Italy, 11-15 April 2011.
- [23] S. Vaccaro, J.R. Mosig, P. de Maagt, "Two advanced solar antenna "SOLANT" designs for satellite and terrestrial communications," IEEE Transactions on Antennas and Propagation, vol.51, no.8, pp. 2028-2034, Aug. 2003.
- [24] M. Danesh, J.R. Long, "Photovoltaic Antennas for Autonomous Wireless Systems," IEEE Transactions on Circuits and Systems II: Express Briefs, vol.58, no.12, pp.807-811, Dec. 2011.
- [25] T. Wu, L. RongLin, and M.M. Tentzeris, "A Scalable Solar Antenna for Autonomous Integrated Wireless Sensor Nodes," IEEE Antennas and Wireless Propagation Letters, vol.10, pp.510-513, 2011.
- [26] K.Niotaki, F. Giuppi, A. Georgiadis and A. Collado, "Solar/EM energy harvester for autonomous operation of a monitoring sensor platform". Wireless Power Transfer, Available on CJO 2014 doi:10.1017/wpt.2014.6
- [27] Z. Popovic, S. Korhummel, S. Dumbar, R. Scheeler, A. Dolgov, R. Zane, E. Falkenstein, J. Hagerty, "Scalable RF Energy Harvesting," Microwave Theory and Techniques, IEEE Transactions on , vol.62, no.4, pp.1046,1056, April 2014.
- [28] N. Shinohara and H. Matsumoto, "Dependence of DC output of a rectenna array on the method of interconnection of its array elements," Elect. Eng. Jpn., vol. 125, no. 1, pp. 9-17, 1998.
- [29] R. J. Gutmann and J. M. Borrego, "Power combining in an array of microwave power rectifiers," IEEE Trans. Microw. Theory Techn., vol. MTT-27, no. 12, pp. 958-968, Dec. 1979.
- [30] J.F. Xu, W. Tai and D.S. Ricketts, "A transmission line based resistance compression network (TRCN) for microwave applications," in Proc. Int. Microw. Symp. (IMS), Seattle, WA, USA, 2013.
- [31] W. Inam, K.K. Afridi, D.J. Perreault, "High Efficiency Resonant dc/dc Converter Utilizing a Resistance Compression Network," IEEE Trans. Power Electron., vol. PP, no. 99, pp.1,1, 0.
- [32] P.A. Godoy, D.J. Perreault and J.L. Dawson, "Outphasing Energy Recovery Amplifier With Resistance Compression for Improved Efficiency," IEEE Trans. Microw. Theory Tech., vol. 57, no. 12, pp.2895-2906, Dec. 2009.
- [33] Xu Junfeng and D.S.Ricketts, "An Efficient, Watt-Level Microwave Rectifier Using an Impedance Compression Network (ICN) With Applications in Outphasing Energy Recovery Systems," IEEE Microw. Wireless Compon. Lett., vol. 23, no. 10, pp. 542-544, Oct. 2013.
- [34] C. Caloz, T. Itoh, Electromagnetic Metamaterials: Transmission line theory and microwave applications, Hoboken, New Jersey, John Wiley & Sons, 2006.



Kyriaki Niotaki was born in Crete, Greece. She received the B.S. in Informatics and the M.S. in Electronic Physics with specialization at Electronic Telecommunication Technology, both from Aristotle University of Thessaloniki (Greece), in 2009 and 2011, respectively. Since December 2011, she has been with

the Centre Tecnologic de Telecomunicacions de Catalunya (CTTC), Barcelona, Spain, as a Research Assistant. Currently, she is working towards her Ph.D. in the Signal Theory and Communications Department of the Technical University of Catalonia (UPC), Barcelona, Spain.

Her main research interests include energy harvesting solutions and the design of power amplifiers. In 2014, she was the recipient of an IEEE Microwave Theory and Techniques Society (IEEE MTT-S) Graduate Fellowship Award.



Ana Collado received the M.Sc. and Ph.D. degrees in Telecommunications Engineering from the University of Cantabria, Spain, in 2002 and 2007 respectively. She is currently a Senior Research Associate and the Project Management Coordinator at the Technological Telecommunications Center of Catalonia (CTTC), Barcelona, Spain

where she performs her professional activities. Her professional interests include active antennas, substrate integrated waveguide structures, nonlinear circuit design, and energy harvesting and wireless power transmission (WPT) solutions for self-sustainable and energy efficient systems.

She has participated in several national and international research projects and has co-authored over 70 papers in journals and conferences. Among her activities she has collaborated in the organization of several international workshops in different countries of the European Union and also a Training School for PhD students. She was a Marie Curie Fellow of the FP7 project Symbiotic Wireless Autonomous Powered system (SWAP). She serves in the Editorial Board of the Radioengineering Journal and she is currently an Associate Editor of the IEEE Microwave Magazine and a member of the IEEE MTT-26 Wireless Energy Transfer and Conversion and MTT-24 RFID Technologies.



Apostolos Georgiadis was born in Thessaloniki, Greece. He received the B.S. degree in physics and M.S. degree in telecommunications from the Aristotle University of Thessaloniki, Greece, in 1993 and 1996, respectively. He received the Ph.D. degree in electrical engineering from the University of Massachusetts at Amherst, in 2002. In 1995, he spent a

semester with Radio Antenna Communications (R.A.C.),

Milan Italy. In 2000, he spent three months with Telaxis Communications, South Deerfield MA. In 2002, he joined Global Communications Devices (GCD), North Andover MA, where he was a Systems Engineer involved with CMOS transceivers for wireless network applications. In June 2003, he was with Bermai Inc., Minnetonka, MN, where he was an RF/Analog Systems Architect. In 2005, he joined the University of Cantabria as a Researcher. He is currently a Senior Research Associate and Group Leader of the Microwave Systems and Nanotechnology Department at Centre Tecnològic de Telecomunicacions de Catalunya (CTTC), Barcelona, Spain, in the area of communications subsystems where he is involved in active antennas and antenna arrays and more recently with RFID technology and energy harvesting.

Dr. Georgiadis was the recipient of a 1996 Fulbright Scholarship for graduate studies with the University of Massachusetts at Amherst, the 1997 and 1998 Outstanding Teaching Assistant Award presented by the University of Massachusetts at Amherst, 1999 and 2000 Eugene M. Isenberg Award presented by the Isenberg School of Management, University of Massachusetts at Amherst, and the 2004 Juan de la Cierva Fellowship presented by the Spanish Ministry of Education and Science. He is involved in a number of technical program committees and serves as a reviewer for several journals including IEEE Transactions on Antennas and Propagation, and IEEE Transactions on Microwave Theory and Techniques. He was the co-recipient of the EUCAP 2010 Best Student Paper Award and the ACES 2010 2nd Best Student Paper Award. He was the Chairman of COST Action IC0803, RF/Microwave communication subsystems for emerging wireless technologies (RFCSET), and the Coordinator of Marie Curie Industry-Academia Pathways and Partnerships project Symbiotic Wireless Autonomous Powered system (SWAP). He is Member of the IEEE MTT-S TC-24 RFID Technologies (Chair 2012-2014) and Member of IEEE MTT-S TC-26 Wireless Energy Transfer and Conversion. He serves at the Editorial board of the Radioengineering Journal and as an Associate Editor of the IEEE Microwave and Wireless Components Letters and IET Microwaves Antennas and Propagation Journals. He is Editor-in-Chief of the Wireless Power Transfer journal by Cambridge University Press.

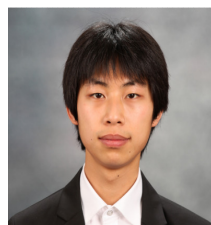

Sangkil Kim (S'12) received the B.S. degree in electrical and electronic engineering from Yonsei University, Seoul, Korea, in 2010. He received the M.S and Ph.D degree in electrical engineering from Georgia Institute of Technology, Atlanta, GA, in 2012 and in 2014, respectively. He is currently pursuing his Ph.D. degree at Georgia Institute of Technology, Atlanta, GA, in 2014. He visited King Abdullah University of Science and Technology (Thuwal, Saudi Arabia, 2013), CTTC (Barcelona, Spain, 2013) and CNRS-LAAS (Toulouse, France, 2013) as a visiting scholar. He is currently working on the

design and fabrication of printed RF energy harvesting-enabled low power sensor platform.



Professor Manos M. Tentzeris received the Diploma Degree in Electrical and Computer Engineering from the National Technical University of Athens ("Magna Cum Laude") in Greece and the M.S. and Ph.D. degrees in Electrical Engineering and Computer Science from the University of Michigan,

Ann Arbor, MI and he is currently a Professor with School of ECE, Georgia Tech, Atlanta, GA. He has published more than 480 papers in refereed Journals and Conference Proceedings, 5 books and 19 book chapters. Dr. Tentzeris has helped develop academic programs in Highly Integrated/Multilayer Packaging for RF and Wireless Applications using ceramic and organic flexible materials, paper-based RFID's and sensors, biosensors, wearable electronics, inkjet-printed electronics, "Green" electronics and power scavenging, nanotechnology applications in RF, Microwave MEM's, SOP-integrated (UWB, multiband, mmW, conformal) antennas and heads the ATHENA research group (20 researchers). He is currently the Head of the GT-ECE Electromagnetics Technical Interest Group and he has served as the Georgia Electronic Design Center Associate Director for RFID/Sensors research from 2006-2010 and as the Georgia Tech NSF-Packaging Research Center Associate Director for RF Research and the RF Alliance Leader from 2003-2006. He was the recipient/co-recipient of the 2012 FiDiPro Award in Finland, the iCMG Architecture Award of Excellence, the 2010 IEEE Antennas and Propagation Society Piergiorgio L. E. Uslenghi Letters Prize Paper Award, the 2011 International Workshop on Structural Health Monitoring Best Student Paper Award, the 2010 Georgia Tech Senior Faculty Outstanding Undergraduate Research Mentor Award, the 2009 IEEE Transactions on Components and Packaging Technologies Best Paper Award, the 2009 E.T.S. Walton Award from the Irish Science Foundation, the 2007 IEEE APS Symposium Best Student Paper Award, the 2007 IEEE IMS Third Best Student Paper Award, the 2007 ISAP 2007 Poster Presentation Award, the 2006 IEEE MTT Outstanding Young Engineer Award, the 2006 Asian-Pacific Microwave Conference Award, the 2004 IEEE Transactions on Advanced Packaging Commendable Paper Award, the 2003 NASA Godfrey "Art" Anzic Collaborative Distinguished Publication Award, the 2003 IBC International Educator of the Year Award, the 2003 IEEE CPMT Outstanding Young Engineer Award, the 2002 International Conference on Microwave and Millimeter-Wave Technology Best Paper Award (Beijing, CHINA), the 2002 Georgia Tech-ECE Outstanding Junior Faculty Award, the 2001 ACES Conference Best Paper Award and the 2000 NSF CAREER Award and the 1997 Best Paper Award of the International Hybrid Microelectronics and Packaging Society. He was the TPC Chair for IEEE IMS 2008 Symposium and the Chair of the 2005 IEEE CEM-TD Workshop and he is the

Vice-Chair of the RF Technical Committee(TC16) of the IEEE CPMT Society. He is the founder and chair of the RFID Technical Committee (TC24) of the IEEE MTT Society and the Secretary/Treasurer of the IEEE C-RFID. He is the Associate Editor of IEEE Transactions on Microwave Theory and Techniques, IEEE Transactions on Advanced Packaging and International Journal on antennas and Propagation. Dr. Tentzeris was a Visiting Professor with the Technical University of Munich, Germany for the summer of 2002, a Visiting Professor with GTRI-Ireland in Athlone, Ireland for the summer of 2009 and a Visiting Professor with LAAS-CNRS in Toulouse, France for the summer of 2010. He has given more than 100 invited talks to various universities and companies all over the world. He is a Fellow of IEEE, a member of URSI-Commission D, a member of MTT-15 committee, an Associate Member of EuMA, a Fellow of the Electromagnetic Academy and a member of the Technical Chamber of Greece. Prof. Tentzeris is one of the IEEE MTT-S Distinguished Microwave Lecturers from 2010-2012.