

**INTERNATIONAL JOURNAL OF ENGINEERING SCIENCES & RESEARCH
TECHNOLOGY****EXPERIMENTAL ANALYSIS OF THE CHARACTERISTIC
PERFORMANCE OF STANDALONE PHOTOVOLTAIC SYSTEM****Birendra Kishore, Anirban Nandy*, O.P. Pandey**

M. Tech Scholar, Energy Technology, Birla Institute of Technology, Mesra, India

*M. Tech Scholar, Energy Technology, Birla Institute of Technology, Mesra, India

Assistant Professor, Department of Mechanical Engineering, Birla Institute of Technology, Mesra,
India**DOI:**

ABSTRACT

This paper demonstrates an insight solar PV Stand Alone system which is a practical model with a halogen light source. At different situations the performance of solar PV cells are analyzed. The system produces power with depending on the change in halogen light intensity & temperature. A theoretical & experimental analysis of the PV cell can be achieved. In this paper the I-V & P-V characteristic of the solar photovoltaic cells with changes in temperature and isolation have been showed. With proper formulation the I-V & P-V data are plotted to get the maximum electrical power output of the PV panel. The effects of variation in intensity of light on solar PV cells are also analyzed.

KEYWORDS: Photovoltaic module, Standalone PV system, Halogen source, Temperature, Radiation intensity.

INTRODUCTION

These are the days of development. Nation like India where industrialization is rapidly growing fossil based fuels is the major source of energy. In terms of energy in India there is a gap in demand & supply. To minimize the gap in demand & supply which is disturbing the progress of industrial sector renewable energy source like solar energy can be utilized [1].

Among renewable sources of energy, solar photovoltaic generation is achieving greater importance. Solar photovoltaic cells offer many advantages. It is a direct energy conversion in which there is no moving parts, no noise and there is negligible wear & tear with little or no maintenance required for proper operation [2].

Solar photovoltaic generation has better potential. The direct energy conversion based on photovoltaic cells has mainly positive qualities. PV array sizing and designing the battery bank for a Stand Alone photovoltaic module is a vital part of the whole system for which the data of solar radiation and load demand are necessary [3].

Photovoltaic cells have existed for many years. They are not commonly utilized for lightening in both domestic and commercial sectors because of the high initial cost and poor conversion efficiency. However with proper research and illustration it might be possible to enhance the quality [4].

Solar energy is directly transformed to electrical energy with the help of PV cell. The design is very convenient and compact compare to thermal solar energy accumulation. If we plot the graph between current and voltage involved in solar cells it is non linear in nature. As the temperature changes voltage & current varies [5].

The objective of the work is to investigate the effect on power generation with respect to intensity. The data collected has been analyzed in a graphical representation. The contribution of renewable energy source is also an aspect. This paper also demonstrates the effect of insolation and temperature on the generation of power.

METHODOLOGY

Solar energy

There are different sources of renewable energy among which solar energy is the most common and beneficial alternate energy source. Solar energy is available in abundant in nature. Rural electrification is an important issue and it is believed that solar energy which can be converted into electrical energy is helping to meet the desired demand.

Solar photovoltaic

An array of several PV cells which is connected in series and parallel with an output of higher voltage & current is known as photovoltaic module. A solar PV module is useful than a single PV cell. Several PV cells are interconnected in a PV module. Generation of power by a PV cell is efficiency dependent. A single cell has an area of 225cm² with cell efficiency of 15%.

Stand alone PV system

In a stand Alone PV system with DC load a PV module is connected through an MPPT, charge controller to the DC load. This system should have battery. Battery is used to accumulate the power of PV system. The stand alone system also offered power to AC load for which an Inverter is required. This configuration is useful in domestic & commercial sectors [6].

Experimental procedure

In this experiment halogen light source were used for irradiation in laboratory. The procedure is devoid of sunlight irradiation. The I-V & P-V characteristic are measured and plotted at different intensity. The PV system which was taken into consideration comprises of two 37watt PV module, halogen light, blogger& plotter. Blogger is the equipment which comprises digital meters, charge controller, MPPT, battery, dc-dc converter & ac-ac converter. Plotter is the equipment which is connected to blogger and computer. In blogger which is digitally supported indicates the reading of current, voltage, dc voltage, ac voltage, dc current, ac current and temperature of the module. The data was collected and the performance of 37 watt PV system was analyzed.

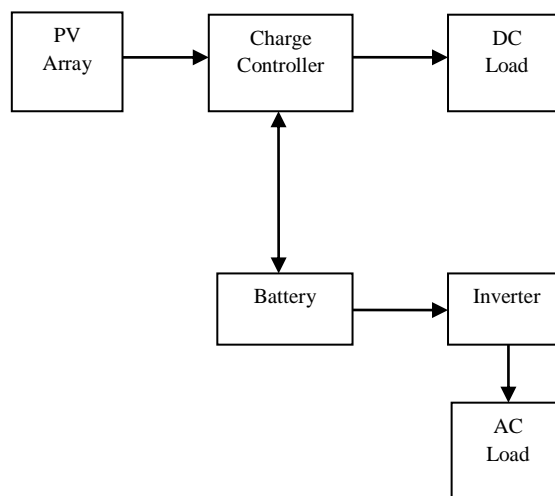

Fig. 1. Schematic diagram of the PV system

Table 1. At 34 (° C) Temperature and 540 (W/m²) Radiation

Voltage(V)	Current(A)	Power(W)
0	0.45	0
5.8	0.42	2.436
16.2	0.36	5.832
19.4	0.22	4.268
19.7	0.16	3.152
19.5	0.12	2.34
20.2	0	0

Table 2. At 31(° C) Temperature and 460 (W/m²) Radiation

Voltage(V)	Current(A)	Power(W)
0	0.37	0
5.3	0.34	1.80
14.1	0.30	4.23
18.4	0.25	4.60
18.8	0.18	3.38
19.1	0.11	2.10
19.4	0	0

Table 3. At 28 (° C) Temperature and 320 (W/m²) Radiation

Voltage(V)	Current(A)	Power(W)
0	0.21	0
4.7	0.20	0.94
10.9	0.18	1.96
15.1	0.16	2.41
17.3	0.15	2.60
17.7	0.13	2.30
18.1	0	0

Table 4. At 24 (° C) Temperature and 250 (W/m²) Radiation

Voltage(V)	Current(A)	Power(W)
0	0.17	0
2.8	0.16	0.44
7.7	0.15	1.15
11.9	0.14	1.66
15.5	0.13	2.01
16.8	0.12	2.02
17.9	0	0

RESULTS AND DISCUSSIONS

Mathematical modeling

Short circuit current (I_{sc})

When the junction is not illuminated then,

$$I = I_0 (\exp (V/V_T - 1))$$

Where,

I_0 = saturation current

V = voltage (PN junction)

V_T = voltage equivalent of temperature

When the junction is illuminated then,

$$I = I_{SC} - I_0 (\exp (V / V_T) - 1)$$

Open circuit voltage (V_{oc})

It is achieved depending on the semiconductor properties,

$$V_{OC} = K_T / q \ln ((I_{SC} / I_0) + 1)$$

Fill factor (FF)

The short circuit current and the open circuit voltage are the maximum current & voltage obtained respectively from a PV cell. The power from the PV cell is zero at these points. The fill factor determines the maximum power from a PV cell,

$$FF = V_m I_m / V_{oc} I_{sc}$$

I-V characteristics

To get the I-V characteristics, the system voltage and current are measured at different irradiances. Pyranometer which is a temperature sensor was used to determine the irradiance. In I-V characteristics, the short circuit current (I_{sc}) is the maximum current at zero voltage.

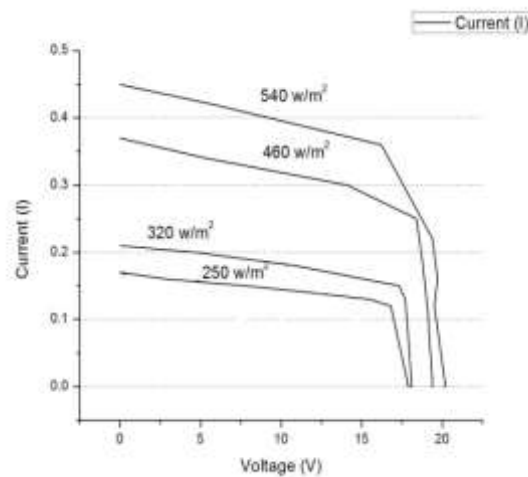

Fig. 2. I-V Characteristic at different radiation intensity

P-V characteristics

To get the P-V characteristics, the system voltage and current are measured at different irradiation. Maximum power is achieved depending on the radiation and temperature of the module. In P-V characteristics, at a single point known as MPPT maximum power is gained. The V_{mp} and I_{mp} are the voltage and current at this point. On varying the solar insolation a short circuit current of the module increases and the open circuit voltage increases slightly.

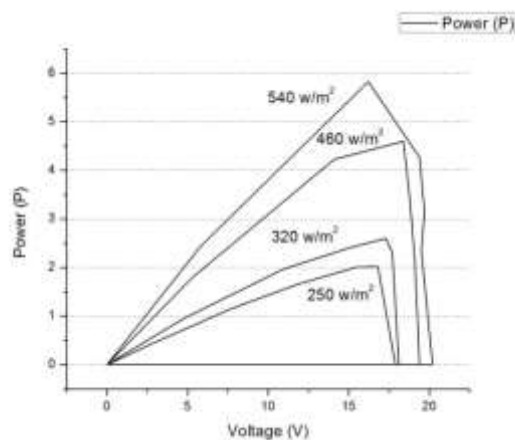

Fig. 3. P-V Characteristic at different radiation intensity

CONCLUSION

The PV module characteristics namely I-V & P-V achieved is in accordance with the theoretical module characteristics. The instrument can be used for I-V & P-V characteristic measurement at different light intensity. It has been shown that power generation increases at greater insolation but there is a decrease in power generation with the rise of temperature.

ACKNOWLEDGEMENTS

This research was made possible thanks to the support of the available equipments at Birla Institute of Technology, Mesra, Ranchi, India. The keen interest of the authors was the driving force behind the major contribution of the paper with several other resources available at Central University of Jharkhand.

REFERENCE

1. A. Nandy, P. Chaki, O. P. Pandey, "A Study on Energy Consumption, Energy Saving and Effectiveness of Alternate Energy Sources in Domestic Sector of India", International Journal of Research in Engineering and Technology, Vol. 5, Issue 2, pp. 183-187, 2016.
2. M. M. H. Bhuiyan, M. Ali Asgar, "Sizing of a stand-alone photovoltaic power system at Dhaka", Renewable Energy, Vol. 28, pp. 929-938, 2003.
3. M. Kolhe, "Techno-Economic Optimum Sizing of a Stand-Alone Solar Photovoltaic System", IEEE Transactions on Energy Conversion, Vol. 24, Issue 2, pp. 511-519, 2009.
4. D. B. Nelson, M. H. Nehrir, C. Wang, "Unit sizing and cost analysis of stand-alone hybrid wind/PV/fuel cell power generation systems", Renewable Energy, Vol. 31, pp. 1641-1656, 2006.
5. N. D. Kaushika, N. K. Gautam, K. Kaushik, "Simulation model for sizing of stand-alone solar PV system with interconnected array", Solar Energy Materials & Solar Cells, Vol. 85, pp. 499-519, 2005.
6. S. P. Adhau, R. Thakre, M. H. Sabley, P. G. Adhau, "Solar Simulator: Hardware implementation to analyse characteristic performance of solar cell", International Conference on Industrial Automation and Computing, Apr. 2014, pp. 1-6.