

Upgraded Ultrasonic Animal Deterrent Device

Vivek Kumar^{#1}, Mohit Kumar#, Sandeep Sharma#

Department of Electronics and Communication Engineering

Dehradun Institute of Technology

Dehradun: 248009, India

¹Student Author – er_vivek@outlook.com

Abstract: In this research work, an upgradation to the pre-existing technology utilizing ultrasound has been proposed to deter animals. Establishing a low input voltage and maintaining a desired operating distance range has been prioritized along with retaining an effective range of random frequency operating on a wide bandwidth region. It ensures a long run of operation by consuming only little amount of energy that can be substantially achieved from solar energy and alternatively from main power in the absence of solar energy.

Index Terms: Ultrasound, Repeaters, Solar energy, Microcontroller 8051

I. INTRODUCTION

The chaos spread by wild animals by crossing the human boundaries has been increasing on an exponential rate. These animals are known to spread various diseases like herpes B virus, rabies, serious wound infection, Rocky Mountain spotted fever, bone infection, tularaemia, toxoplasmosis etc. Severe toxoplasmosis can even cause damage to the eyes, brain or other organs. Henceforth, a solution is indeed needed to prevent humans from such diseases occurring from wild animals ([1]). Many methods have been prevailed to tackle this problem including scarecrow, fences, hunters etc. But each of them lacks at a point of time pertaining to their physical limitations, capital requirement, availability, and so on. Therefore, a new method had developed which utilized ultrasound to restrict animals from its range to overcome its antecedent's loopholes. Ultrasonic devices operate through emitting short wavelength, high frequency sound waves that are too high in pitch to be heard by the human ear (all frequencies greater than 20,000 Hz). Humans are unable to hear sounds higher than 20 kHz due to physiological limitations of the cochlea ([2]). However, the prevailing method of using ultrasound as a deterrent has too got many drawbacks. So, overcoming the loopholes of this electronically animal repellent method is the focus of the study.

In this paper, we focus upon enhancing the features of the ultrasonic animal deterrent device to make it more efficient and reliable for the current human needs. Ameliorated features include driving the device with the solar power and operating the device at a low voltage supply of +3V while maintaining a battery backup as an alternative power source. Moreover, establishing a random operating frequency to ensure that particular species of animal doesn't get used to a constant frequency. Finally, use of the repeaters have been emphasised to increase the operating distance range and cover a vast area.

The paper has been sub-divided into VI sections. We premise our approach in section II. Section III sparks light upon the algorithm used to determine the input source and to generate random or variable frequency. Simulation results are provided in section IV. Proceeding ahead, section V derives the conclusion. The paper ends in the section VI giving the references of the work.

II. PRINCIPLE OPERATION

Ultrasound has been used as a deterrent technique for animals like monkeys, stray dogs, rodent, birds etc. because of its remarkable features while maintaining cost. The device operates on a frequency band of 10 kHz – 100 kHz. The sound is not pleasant but the volume is well under any level of intensity (loudness, decibels) that would cause injury, whether or not it is "heard." It makes animals leave by making the space uncomfortable, not dangerous ([3]). Table 1 defines the hearing

range of different species of animals on the basis of their operating frequency range. Therefore, emitting a frequency closest to the given bands make corresponding animals uncomfortable, making them to leave the area.

Table 1: Hearing range of wild animals ([4]), ([5])

S. No.	Animals	Frequency Range
1.	Birds, Squirrels, Monkeys, Raccoon, Deer, etc.	10-35 kHz
2.	Dog, Cat, Gerbil, Guinea pig, Ferret, Beetles, Ants, Boars, etc.	36-65 kHz
3.	Rat, Mouse, etc.	66-100 kHz

Procedure: The basic layout of the device is given in the Fig. 1. The figure composed of solar power energy source, battery, voltage regulator, microcontroller, ultrasonic transmitter, and finally various repeaters.

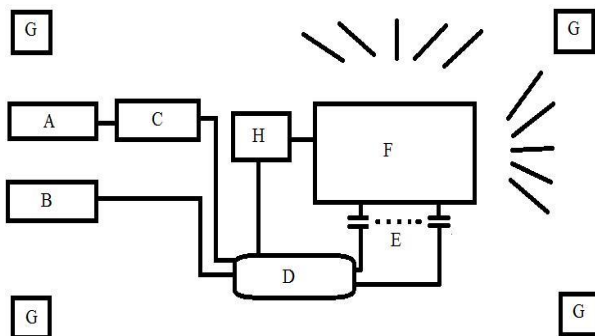

Fig. 1: Basic layout of the device

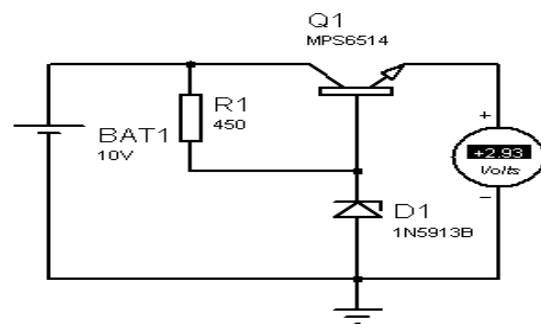

Fig. 2: Solar cell with Voltage Regulator

In Fig. 1, **A** and **B** signifies to the solar power supply (V_s) and the battery supply (V_b) used respectively to provide the input to the circuit. After V_s , a voltage regulator (**C**) is connected to ensure the constant supply of the voltage at +3V.

Fig. 2 depicts the voltage regulator using a zener diode corresponding to the solar cell. After obtaining a +3V of input power supply from either of the source, the first task of the microcontroller 8051(**D**) starts. It compares the voltage from both the inputs and gives priority to the V_s keeping V_b as an alternative. After deciding the source the next task is to use the voltage multiplier (**H**) (here, voltage tripler) to amplify the source voltage. Voltage multipliers are AC-to-DC power conversion devices, comprised of diodes and capacitors that produce a high potential DC voltage from a lower voltage AC source ([6]). Fig. 3 shows the circuit used for the voltage tripler using IC 555. The circuit is actually a cascaded form of voltage doubler, i.e. the input voltage gets doubled after diode D2 and diode D4 respectively. Hence, providing an input voltage of +3V gives an output voltage of +5~6V after diode D2 which acts as an input voltage for the next cascaded network giving an output voltage of around +9~10V (here, +9.10V) after diode D4.

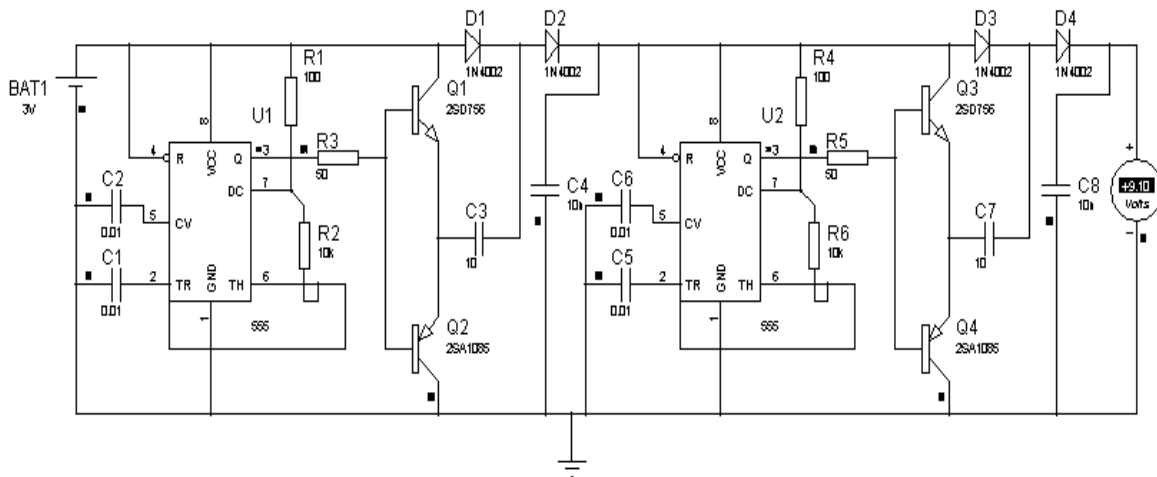

Fig. 3: Voltage Tripler

Now, the output voltage +9V is sufficient to drive the ultrasonic sound transmitter (F). The ultrasonic transmitter produces a variable frequency ranging from 10 kHz to 100 kHz. Fig. 4 shows the circuit diagram of ultrasonic sound transmitter.

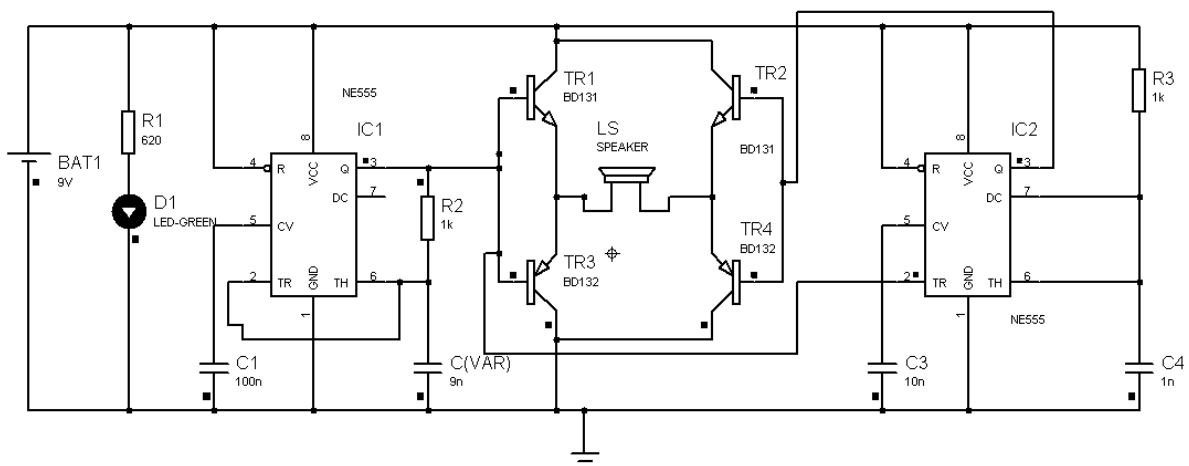

Fig. 4 Ultrasonic Sound Transmitter

It uses a standard 555 timer IC1 set up as an oscillator using a single RC network to give a frequency between 10-100 kHz square waves with equal mark/space ratio. This frequency is above the hearing threshold for humans but is known to be irritating frequency for monkeys, dogs, cats etc.

Since the maximum current that a 555 timer can supply is 200mA an amplifier stage was required so a high-power H-bridge network was devised, formed by 4 transistors TR1 to TR4. A second timer IC2 forms a buffer amplifier that feeds one input of the H-bridge driver, with an inverted waveform to that of IC1 output being fed to the opposite input of the H-bridge.

This means that conduction occurs through the complementary pairs of TR1/TR4 and TR2/TR3 on alternate marks and spaces, effectively doubling the voltage across the ultrasonic transducer, LS. This is optimised to generate a high output at ultrasonic frequencies.

Further, to produce a variable frequency in between the range of 10-100 kHz a series of capacitors (E) is assembled with the ultrasonic transmitter circuitry. The capacitor C (VAR) of the Fig. 4 corresponds to the series of different ranging capacitors whose working is controlled via microcontroller (D). Microcontroller is programmed in such a manner that each of the following

capacitor is kept on only for a particular duration of time. This ensures that different frequencies are emitted from the circuit making it difficult for a single species of animal to adapt the change and simultaneously covering a long band of ultrasonic frequencies. The given circuitry can also be utilized only for a specific species of animal too by restricting the varying emitted frequencies only to their range. However, we have chosen frequency for each of the three bands (Refer Table 1) to get our result.

Finally, the transducer LS emits omnidirectional ultrasonic waves. But, because of the prevailed noises in the environment either due to natural factors or artificial/man-made factors a reduction in the Signal to Noise Ratio (SNR) is often seen. Therefore, to boost the strength of the signals and extend their range the concept of implementing repeaters (G) have been introduced. They receive a signal and re transmits it at a higher level or higher power, or onto the other side of an obstruction, so that the signal can cover longer distances. So, it depends on the human where he wants to expand the range of the transmission providing him complete flexibility under less cost regardless of buying a whole new device.

III. ALGORITHMS USED BY THE M.C.U 8051:

1. Determination of input power supply:

The input from both of the source is controlled by the microcontroller. It periodically checks the available input from the V_s , if it is more than a certain threshold voltage (here, +3V) then giving it priority against V_b it short circuit the network between the voltage regulated V_s and the voltage tripler. However, if the original voltage V_s is less than the threshold voltage then V_b is chosen as an input voltage for the device.

2. Specifying the capacitors:

Here, six different ranges of capacitors are connected to the I/O terminals (P.1.0 – P.1.5) of the microcontroller 8051 ([7]) with their other end on the 6th pin of the IC1 of Fig. 4 corresponding to the C (VAR). Microcontroller is programmed in such a way that it powers a certain pin only for a fixed period of time and then changes the connection for a different pin. This process repeats in a loop providing a variable frequency at the output terminal of the circuit i.e. at LS of Fig. 4.

IV. SIMULATION RESULTS:

We test our result on Proteus using the proposed algorithm and depict the waveform for each frequency band given in table 2.

Table 2: List of capacitors along with their output frequency

Serial No.	Capacitance (in nF)	Frequency (in kHz)
1.	70	10
2.	35	20
3.	15	50
4.	10	57.14
5.	9	74.07
6.	8	90.90

Waveforms: Below are six waveforms corresponding to the capacitance range as provided in the table 2. The time per division scale is set to $5 \mu\text{s}$ ([8]).

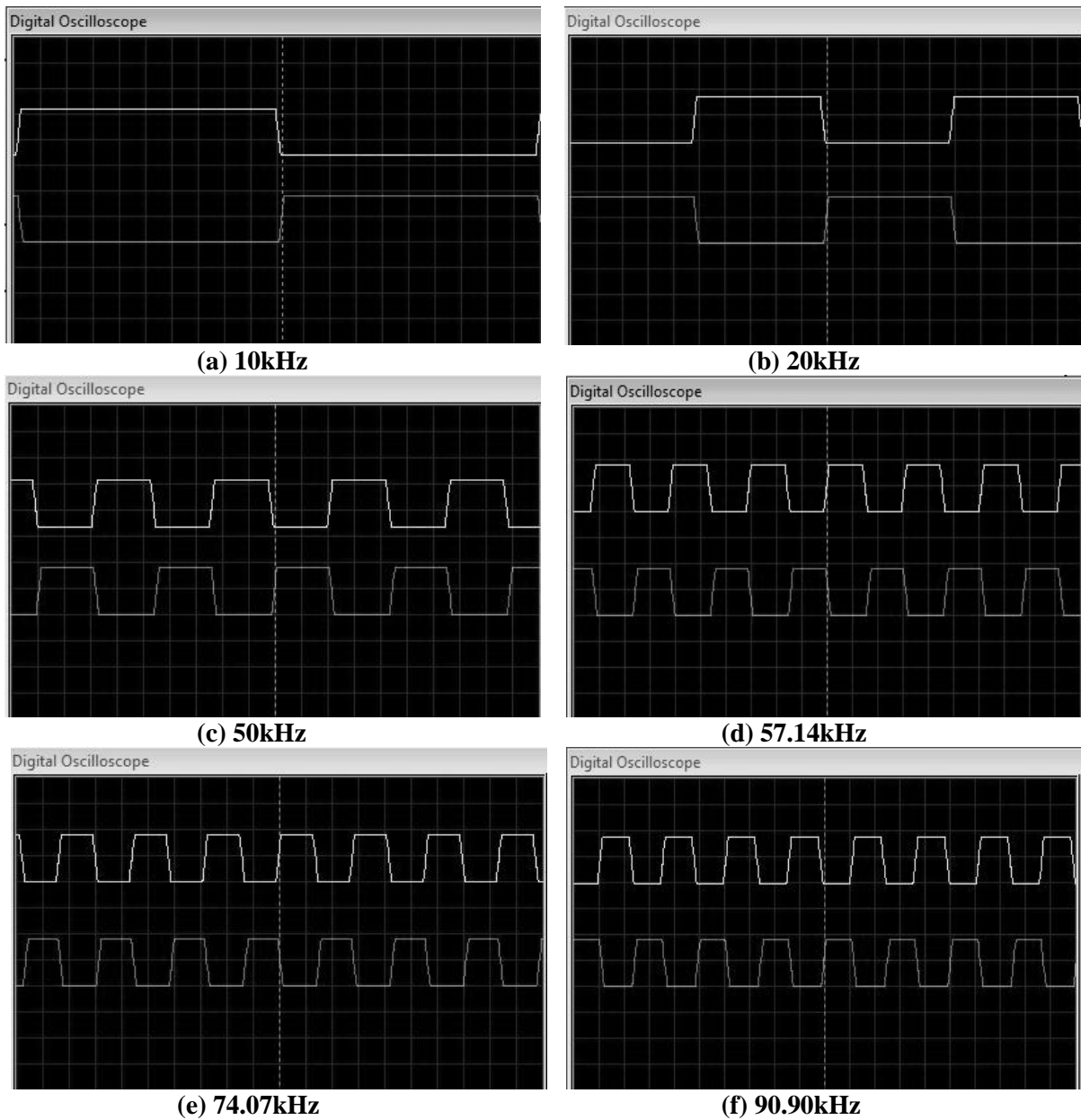

Fig. 5: Waveforms for different capacitance range

V. CONCLUSION:

The upgraded device has overcome many loopholes of the currently prevailed ultrasonic animal deterrent device. It works on solar powered energy and simultaneously reduces the input power supply to one-third of its antecedent. Operating on a long distance range and covering a big portion of ultrasonic band to make different species of wild animals uncomfortable in its area coverage has made it more user-friendly and reliable for the customers.

VI. REFERENCES.

- [1] D Geraint James, "A clinicopathological classification of granulomatous disorders", *Postgrad Med J* 2000;76:457-465 doi:10.1136/pmj.76.898.457

- [2] Richard A. Lopchinsky, MD, FACS and Nancy H. Van Name, RDMS, RTR, and Marlene Kattaron, RDMS, "Physical Principles of Ultrasound", 2000.
- [3] <http://www.promptpestcontrol.com/knowledge-center/ultrasonic-sound-safety/>
- [4] RR Fay. 1988. Hearing in Vertebrates: a Psychophysics Databook. Hill-Fay Associates, Winnetka IL.
- [5] RR Fay & AN Popper, eds. 1994. Comparative Hearing: Mammals. Springer Handbook of Auditory Research Series. Springer-Verlag, NY.
- [6] Multipliers, Design Guide, Introduction, P. No. 281.
- [7] Muhammad Ali Mazidi, Janice Gilispie Mazidi, "The 8051 Microcontroller and Embedded Systems" P. No. 23.
- [8] Microcomputer system design, 2- Introduction to Proteus VSM (Part II).