

DOI:

ABSTRACT

This paper presents the performance analysis of transformer less dc-dc converters to achieve high step-up voltage gain without an extremely high duty ratio. The technique used to design the equivalent circuit of these converters is switched-inductor with voltage lift circuit, allowing a boost of the input voltage to high values. In this paper describes the steady-state analysis of voltage gain for all the converters(dc-dc step up, dc-dc step down). For the execution of proposed converters the MATLAB/SIMULINK software has been used. Finally the comparative analysis of proposed converters with conventional boost converter which shows that proposed converters have higher voltage gain and reduced voltage stress.

KEYWORDS: Power Stage, Transformerless DC-DC Boost Converter, Voltage Gain, Voltage Lift Circuit, Voltage Stress

INTRODUCTION

In many technical applications, it is required to convert a set voltage DC source into a variable-voltage DC output. A DC-DC switching converter converts voltage directly from DC to DC and is simply known as a DC Converter. A DC converter is equivalent to an AC transformer with a continuously variable turns ratio. It can be used to step down or step up a DC voltage source, as a transformer. DC converters are widely used for traction motor control in electric automobiles, trolley cars, marine hoists, forklifts trucks, and mine haulers. They provide high efficiency, good acceleration control and fast dynamic response. They can be used in regenerative braking of DC motors to return energy back into the supply. This attribute results in energy savings for transportation systems with frequent steps. DC converters are used in DC voltage regulators; and also are used, with an inductor in conjunction, to generate a DC current source, specifically for the current source inverter.

The boost converter is one of the most important non isolated step-up converter, however the operation with high input current and high output voltage, became impracticable the development of high performance converter, due to efficiency degradation and dynamic range limitation. Although, a dc-dc boost converter can achieve a high step-up voltage gain with an extremely high duty ratio [1]-[3]. However, the step-up voltage gain is limited due to the effect of power switches, rectifier diodes, and the equivalent series resistance of inductors and capacitors and also the extremely high duty-ratio operation will result in a serious reverse recovery problem.

Many topologies are designed to get higher voltage gain without an extremely high duty ratio, but the voltage stress on active switch is high due to the leakage inductance of the transformer [4]-[8]. The coupled-inductor techniques propose the solution to achieve high voltage gain, low voltage stress on the active switch without high duty ratio [5]-[10]. The modified boost type with switched-inductor technique is presented in [9]. Only one power stage is used in this converter; however the voltage stress on active switch is equal to the output voltage. A transformerless dc-dc converter is proposed [10] to reduce the voltage stress less than the output voltage as compared to the converter presented in [9]

This paper also describes the operating principle and performance analysis of boost converter and proposed converters in continuous-conduction-mode because in continuous conduction mode converters have low losses. A transformer less dc-dc high step up proposed converters have following benefits:-

- Two power devices exist in current flow path during the switched on period & one power device exist in current flow path during the switched off period.
- The voltage stresses on the active switches are less than the output voltage.
- Under the same operating conditions, including input voltage, output voltage, and output power, the current stress on the active switch during the switch-on period is equal to the half of the current stress on the active switch of the converter in modified boost converter.

This proposed dc-dc converters presented in this paper utilize the switched inductor technique, in which two inductors with same level of inductance are charged in parallel during the switch-on period and are discharged in series during the switch-off period, to achieve high step-up voltage gain without the extremely high duty ratio.

To analyze the steady state characteristics of the proposed converters following conditions are considered:

- All components are ideal—the ON-state resistance of the active switches, the forward voltage drop of the diodes, and the ESRs (equivalent series resistance) of the inductors and capacitors are ignored.
- All capacitors are sufficiently large, and the voltages across the capacitors can be treated as constant.

Converter Topology

A. Boost Converter

The boost converter is a very popular non-isolated topology effectively used to transform an input voltage into a higher output voltage. Boost converter works as a step-up converter i.e. it gives an output voltage V_0 which is greater than the input voltage V_s by the factor $1/(1-D)$, where D is duty ratio of the switch. The circuit diagram for boost converter as shown in Figure 1.

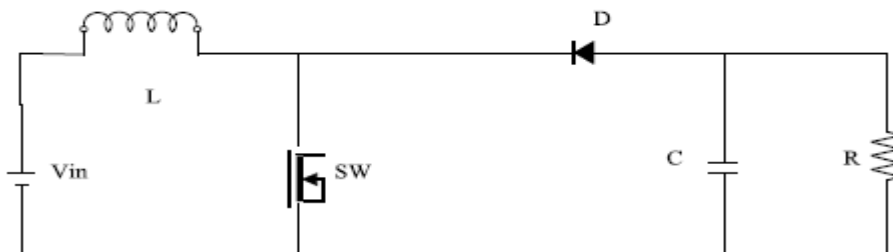

Figure 1. Equivalent circuit of boost converter

When the switch sw is closed as shown in Figure 2. The inductor current will flow through the short circuit Path and the two governing dynamic equations for this ON condition will be

$$V_{in}t_{on} + (V_{in} - V_o)t_{off} = 0 \quad (1)$$

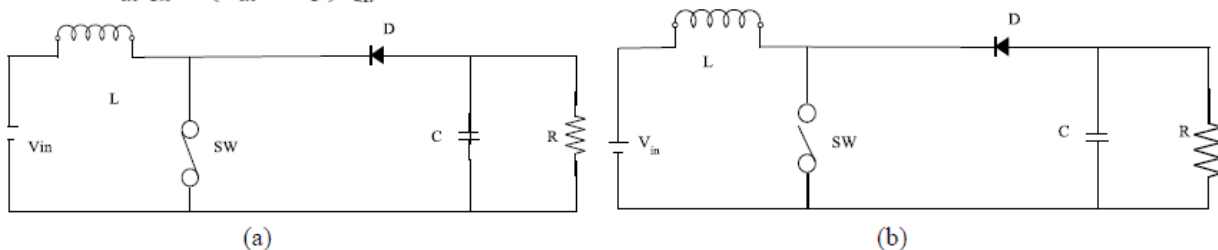

Figure 2. Equivalent circuit of boost converter when

(a) When switch ON (b) When switch OFF

Thus the voltage gain obtained as

$$M_{ccm} = \frac{V_o}{V_{in}} = \frac{T}{t_{off}} = \frac{1}{1-D} \quad (2)$$

B. Proposed Converter I

Figure 3 shows the circuit configuration of the proposed converter I, which consists two active switches S1, S2, two inductor L1 & L2 with same level of inductance, one output diode Do & output capacitor Co. Switches S1 and S2 are controlled simultaneously by one control signal.

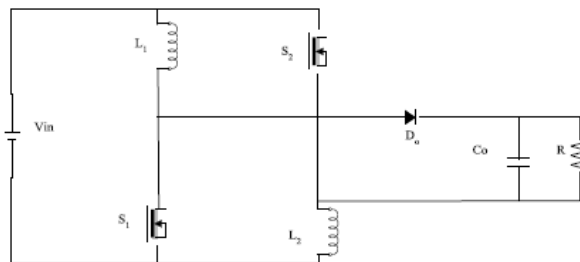

Figure 3. Equivalent circuit of proposed converter I

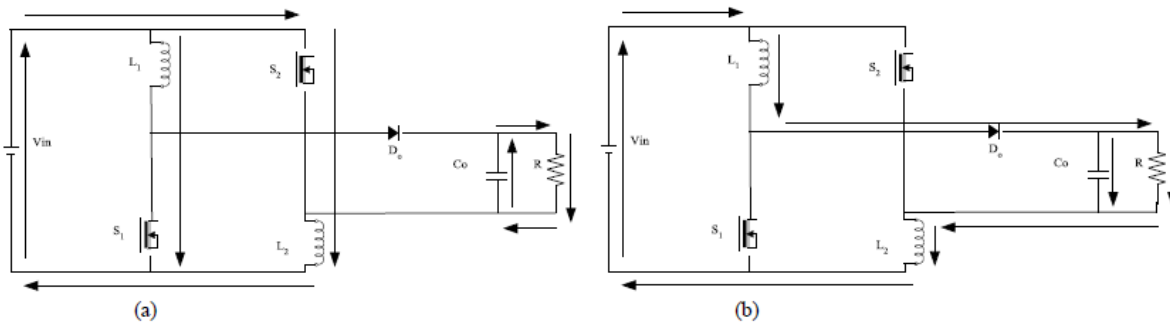

Figure 4. Equivalent circuit of proposed converter I

(a) When switch ON (b) When switch OFF

❖ Steady State Analysis Of Proposed Converter I in Continuous Conduction Mode

The operating modes can be divided into two modes, defined as modes 1 and 2.

- Mode 1 [t0, t1]. During this time interval, switches S1 and S2 are turned on. Inductors L1 and L2 are charged in parallel from the dc source, and the energy stored in the output capacitor Co is released to the load. Thus, the voltages across L1 and L2 are given as

$$V_{L1} = V_{L2} = V_{in} \quad (3)$$

- Mode 2 [t1, t2]. During this time interval, S1 and S2 are turned off. The dc source, L1, and L2 are series connected to transfer the energies to Co and the load. Thus, the voltages across L1 and L2 are derived as

$$V_{L1} = V_{L2} = \frac{V_{in} - V_o}{2} \quad (4)$$

- By using the volt-second balance principle on L1 and L2, the following equation can be obtained:

$$\int_0^{DT_s} V_m dt + \int_{DT_s}^{T_s} \frac{V_m - V_o}{2} dt = 0 \quad (5)$$

By solving (5), the voltage gain is given by

$$M_{ccm} = \frac{V_o}{V_m} = \frac{1+D}{1-D} \quad (6)$$

The voltage stress on S1, S2, Do can be derived as

$$V_{s1} = V_{s2} = \frac{V_o + V_m}{2} \quad (7)$$

$$V_{D0} = V_o + V_m \quad (8)$$

C. Proposed Converter II

Figure 5 shows the circuit configuration of the proposed converter II, which is the proposed converter I with two voltage-lift circuit. Thus, two inductors (L1 and L2) with the same level of inductance are also adopted in this converter. Switches S1 and S2 are controlled simultaneously by one control signal.

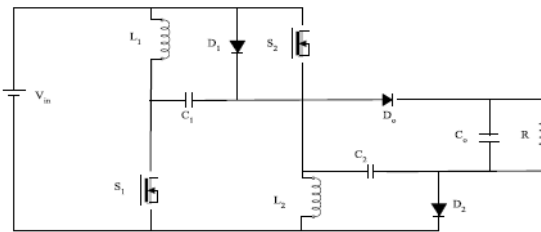

Figure 5. Equivalent circuit of proposed converter II

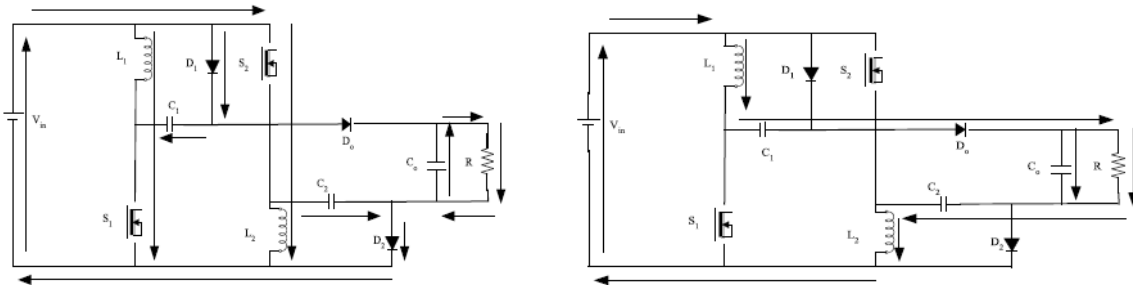

Figure 6. Equivalent circuit of proposed converter II
(a) When switch ON (b) When switch OFF

❖ Steady State Analysis of Proposed Converter II in Continuous Conduction Mode (CCM)

The operating modes can be divided into two modes, defined as modes 1 and 2.

- Mode 1 [t0, t1]. During this time interval, S1 and S2 are turned on. L1 and L2 are charged in parallel from the dc source, and the energy stored in Co is released to the load. Moreover, capacitor C1 and C2 are charged from the dc source. Thus, the voltages across L1, L2, and C1 and C2 are given as

$$V_{L1} = V_{L2} = V_{C1} = V_{C2} = V_m \quad (9)$$

- Mode 2 [t1, t2]. During this time interval, S1 and S2 are turned off. The dc source, L1, C1, C2 and L2 are series connected to transfer the energies to Co and the load. Thus, the voltages across L1 and L2 are derived as

$$V_{L1} = V_{L2} = \frac{V_m + V_{C1} + V_{C2} - V_o}{2} = \frac{3V_m - V_o}{2} \quad (10)$$

By using the volt-second balance principle on L_1 and L_2 , the equation can be obtained

$$\int_0^{DT_s} V_{in} dt + \int_{DT_s}^{T_s} \frac{3V_{in} - V_o}{2} dt = 0 \quad (11)$$

By simplifying (11), the voltage gain is given by

$$M_{CCM} = \frac{V_o}{V_{in}} = \frac{3-D}{1-D} \quad (12)$$

The voltage stress on S1, S2, D1, D2 and Do can be derived as

$$V_{S1} = V_{S2} = V_{D1} = V_{D2} = \frac{V_o - V_{in}}{2} \quad (13)$$

$$V_{D_o} = V_o - V_{in} \quad (14)$$

Simulation of Conventional Boost Converter & Proposed Converters

To verify the operation and performance of the converters described in this section, simulation is done in Matlab with following parameters:

- Input voltage V_{in} : 12 V
- Output voltage V_o : 100 V
- Switching frequency : 1 kHz
- Power P_o : 40 W

For the simulation purpose, the tool box used is the sim-power system tool box. This section provides the details of simulation which is performed on the conventional boost converter and proposed converters with same design factors mentioned above. Simulation results are presented in this section which is in agreement with the theoretical analysis.

❖ Simulation of Conventional Boost Converter

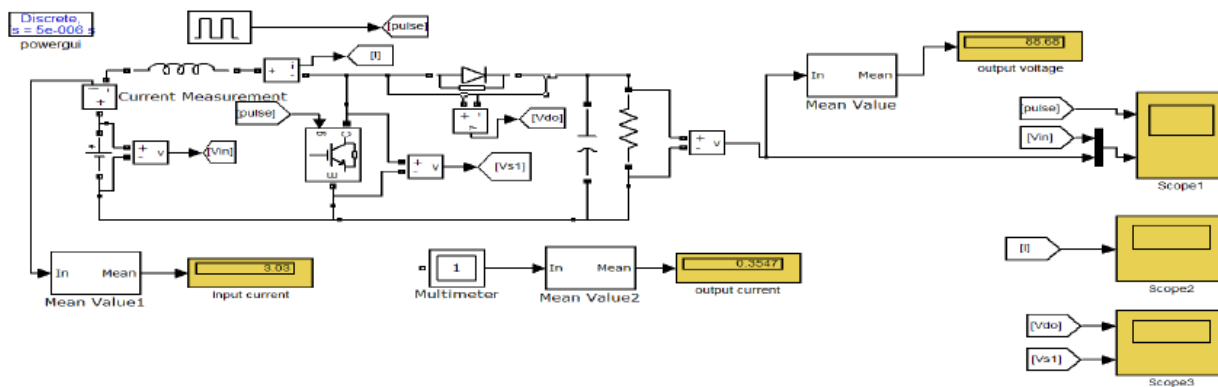

Figure 7. Simulation diagram of boost converter

Load resistance is 250Ω and inductor $L = 10 \text{ mH}$. Switch S1 is IGBT switch which is controlled by using control signal which is square pulse with amplitude 1 V with duty cycle as calculated below.

Duty cycle can be calculated by using (2)

$$\frac{V_o}{V_{in}} = \frac{1}{1-D} = \frac{100}{12} \quad (15)$$

$$D = 88\% \quad (16)$$

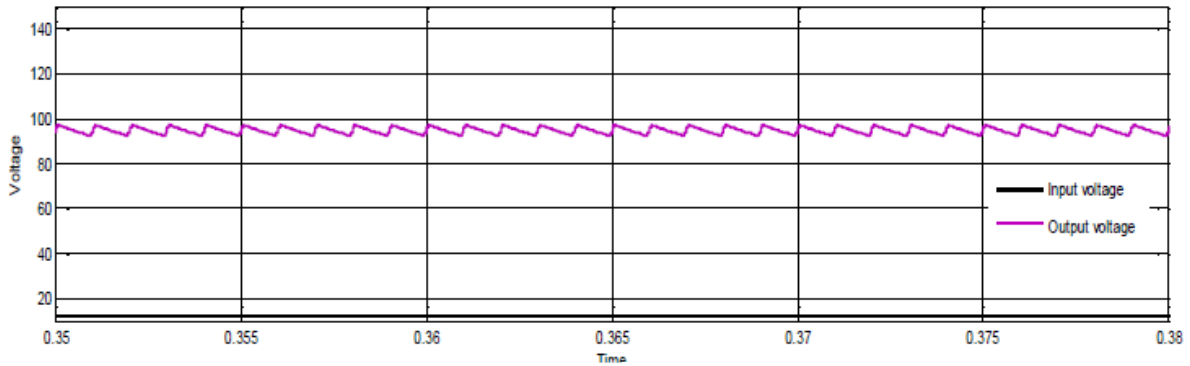

Figure 8. Input/Output voltage of boost converter

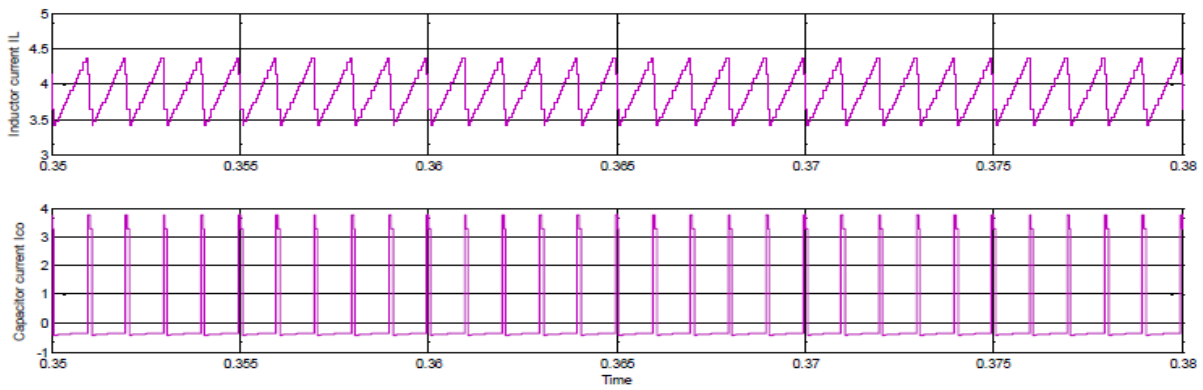

Figure 9. Current across inductor L & output capacitor Co

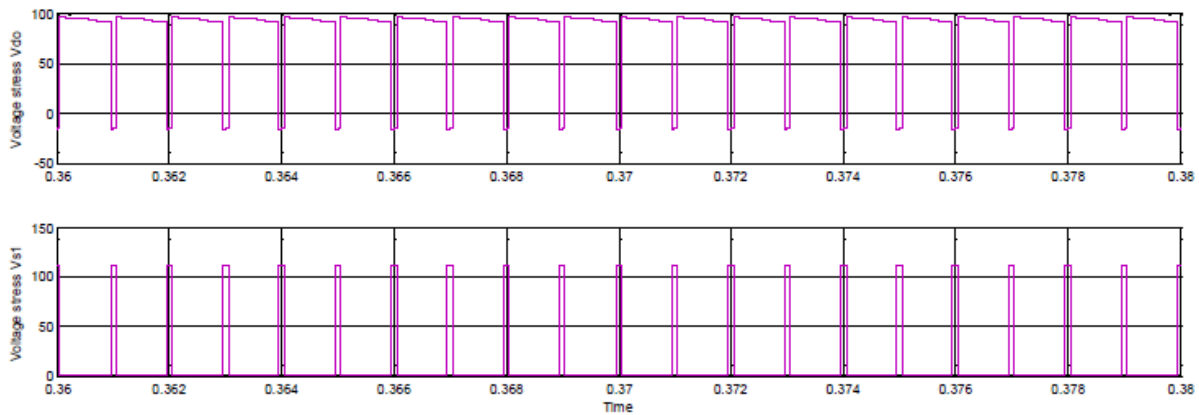

Figure 10. Voltage stress across output diode D0 & switch S1

❖ **Simulation of Proposed Converter I**

Load resistance R= 250 Ω, inductor L1=L2=10 mH, filter capacitor CO=68 μF. Switch S1 and S2 are IGBT switches which are controlled by using one control signal which is square pulse with amplitude 1 V with duty cycle as calculated below.

$$\frac{V_o}{V_{in}} = \frac{1+D}{1-D} = \frac{100}{12} \tag{17}$$

$$D = 78.57\% \tag{18}$$

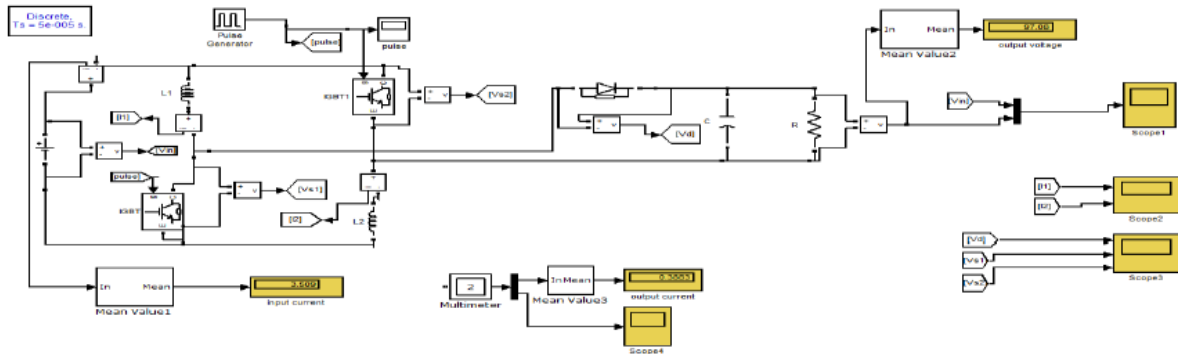

Figure 11. Simulation diagram of proposed converter I

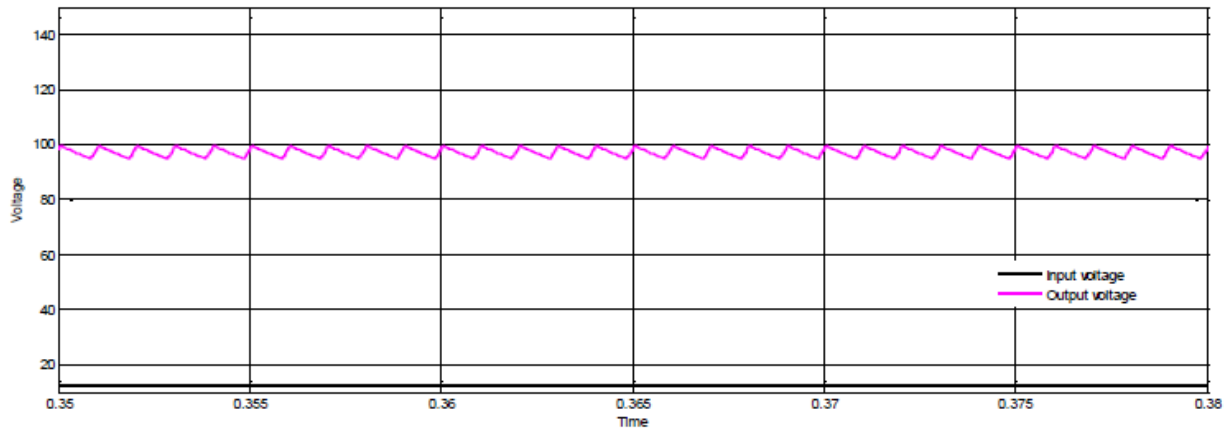

Figure 12. Input/Output voltage of boost converter

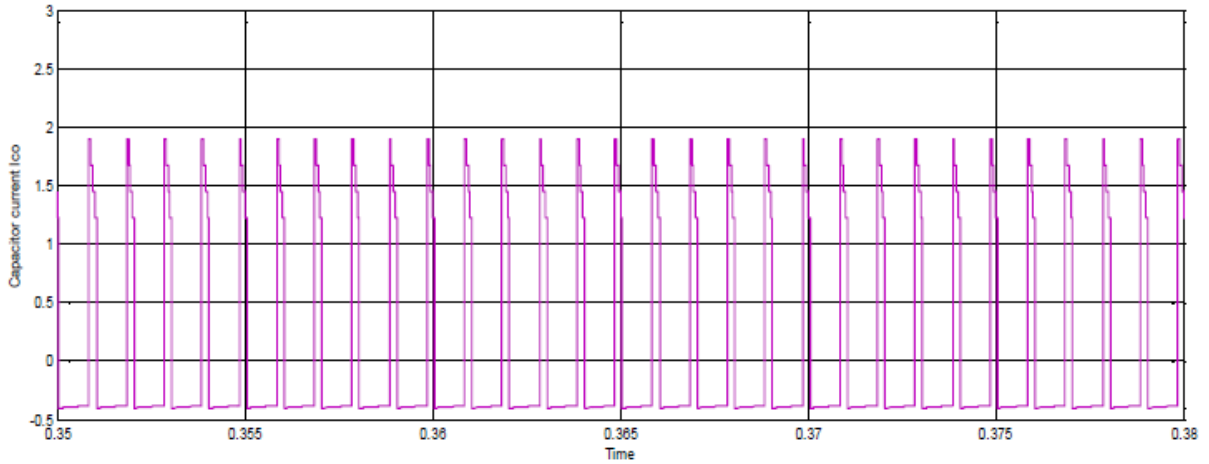

Figure 13. Current across filter capacitor C0

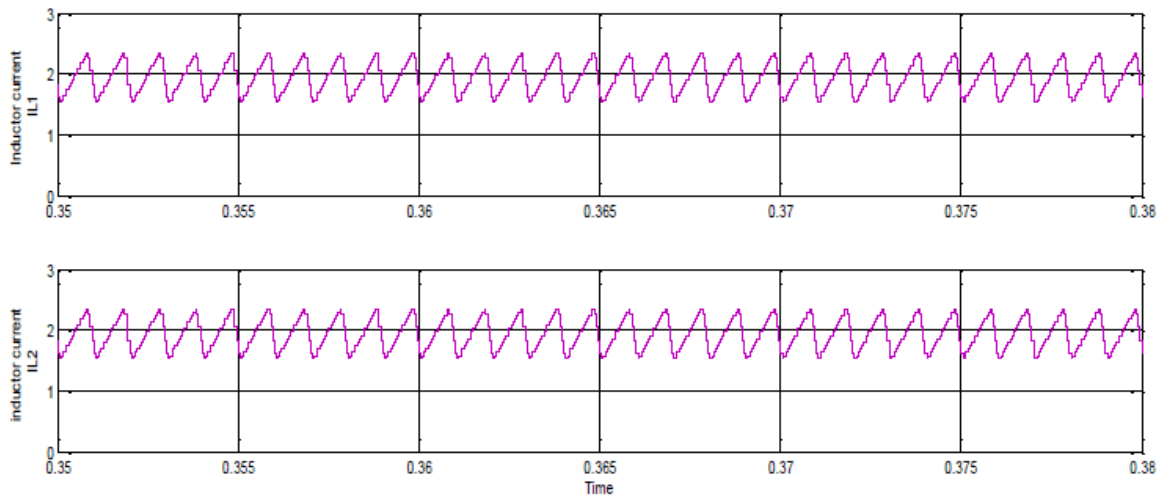

Figure 14. Inductor current across L1 & L2

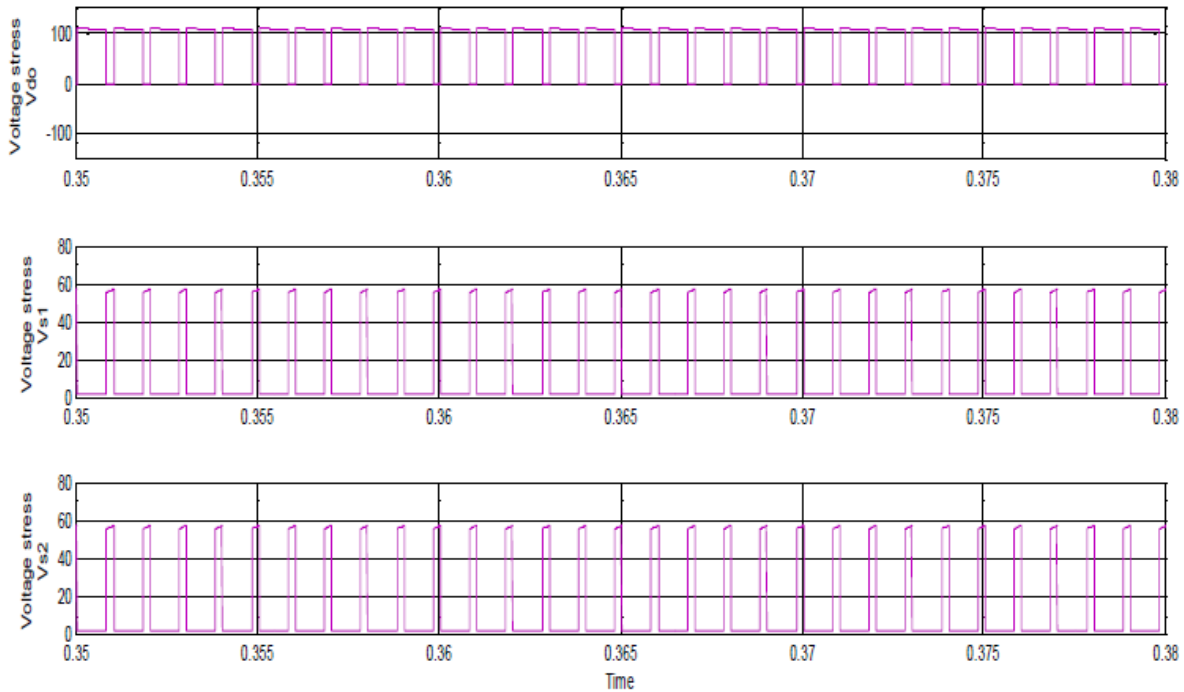

Figure 15. Voltage stress across switches

❖ **Simulation of Proposed Converter II**

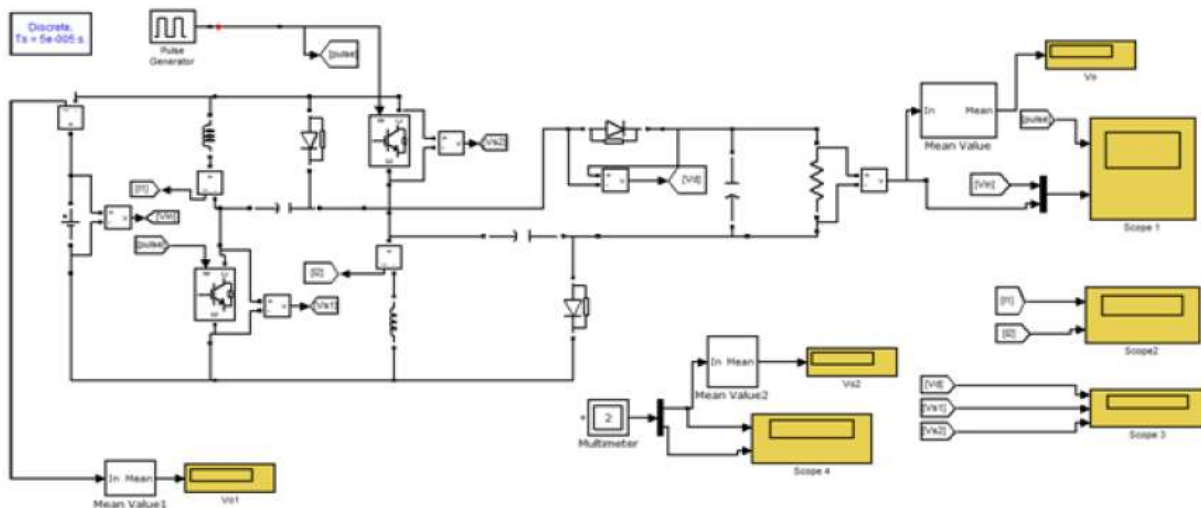

Figure 16. Simulation diagram of proposed converter II

Load resistance $R = 250 \Omega$, inductor $L_1 = L_2 = 10 \text{ mH}$, filter capacitor $C_0 = 68 \mu\text{F}$, $C_1 = 57 \mu\text{F}$. Switch S_1 and S_2 are IGBT switches which are controlled by using one control signal which is square pulse with amplitude 1 V with duty cycle as calculated below.

$$\frac{V_o}{V_{in}} = \frac{3-D}{1-D} = \frac{100}{12} \quad (19)$$

$$D = 72.72\% \quad (20)$$

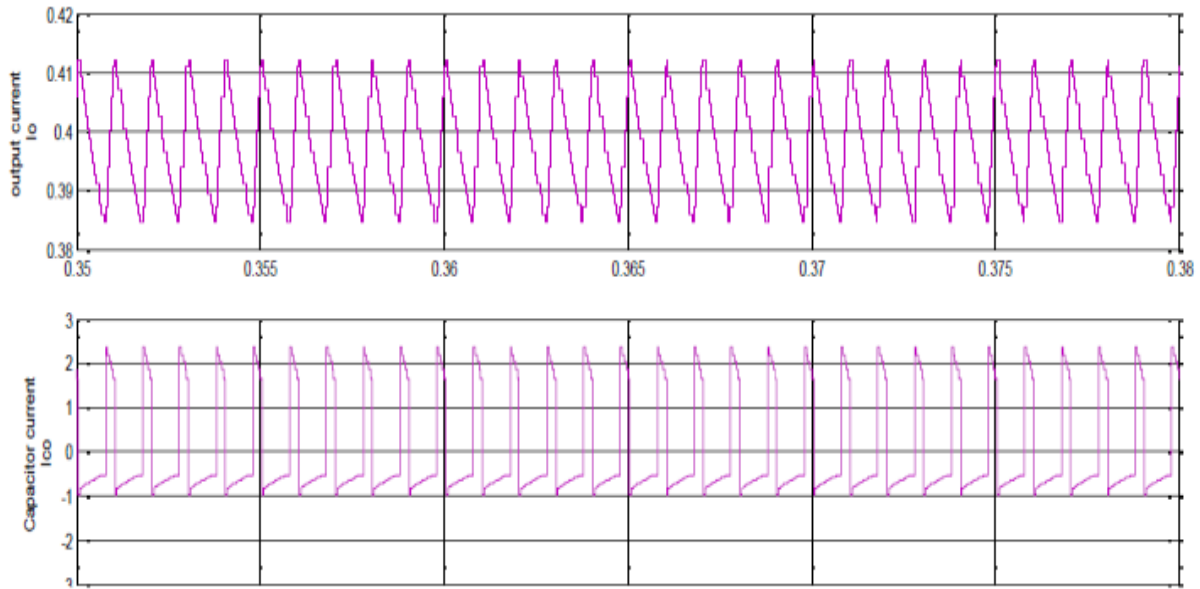

Figure 17. Output current across resistance R and filter capacitor C0

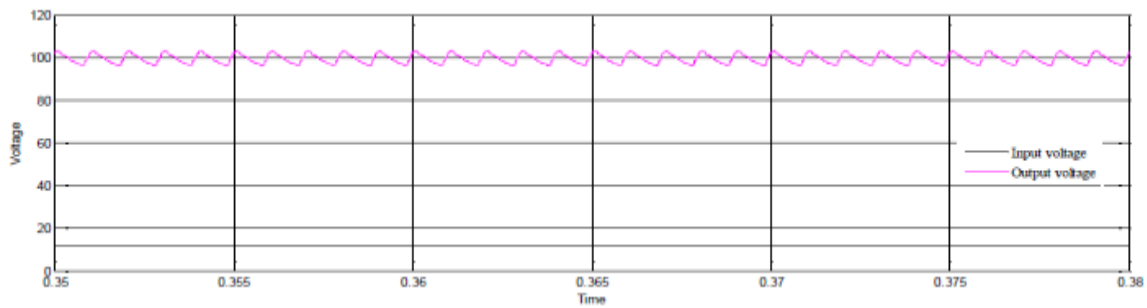

Figure 18. Input/Output voltage of converter

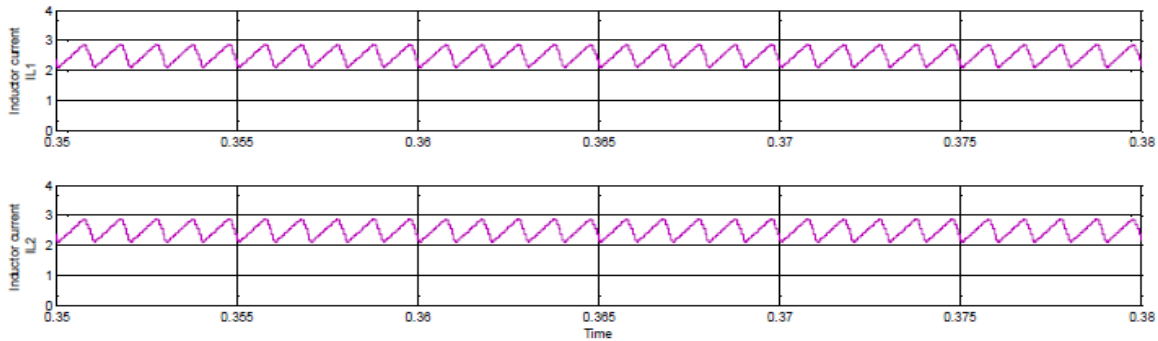

Figure 19. Inductor current across L1 & L2

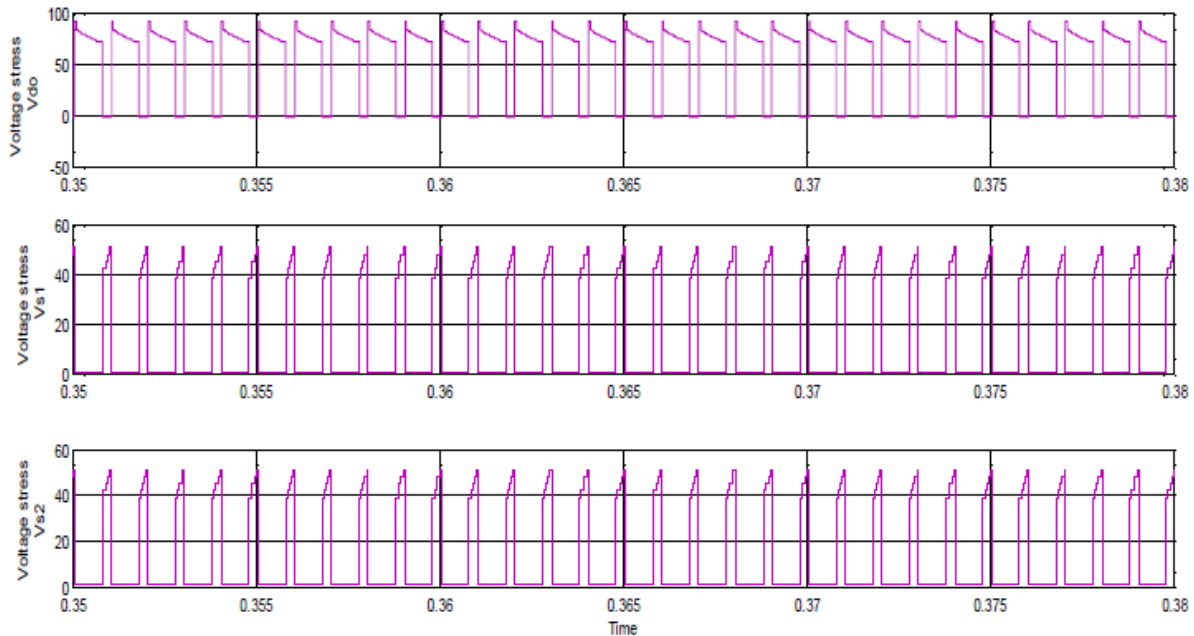

Figure 20. Voltage stresses across switches

Comparison Between Proposed Topologies and Simple Boost Topology

Table I gives comparison between the simple and the improved boost converter topologies in terms of voltage gain and active switch voltage stress. The converters are designed to operate at 12 V-100 V with output power 40 W. Simulation is done in open loop environment and from table it is concluded that the proposed converter II can obtain the approximate equal value as required at low duty cycle compared to other topologies. Considering the table values, it is clear that the improved topologies have a lower switch voltage stress and high voltage gain than the simple one. This add-value gives the possibility of using switches of lower voltage ratings and lower on-state resistance.

Converter	Duty cycle (%)	Voltage gain (Volt)	Output current (Amp)	Voltage stress (Volt)	output power (Watt)
Boost converter	88	91.66	0.3666	92	33.60
Proposed converter I	78.57	97.08	0.3883	54.54	37.69
Proposed converter II	72.72	99.46	0.3979	43.73	39.57

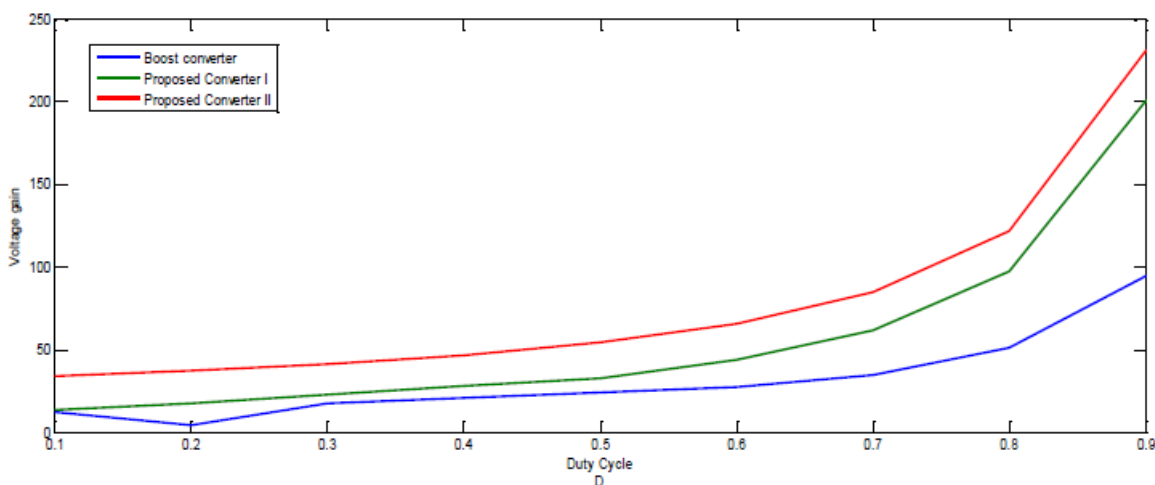

Figure 21. Voltage gain comparison of conventional & proposed boost converters

CONCLUSION

This paper has studied the performance analysis of conventional boost converter and proposed boost converters in continuous conduction mode. The converters use the switched inductor technique, in which same amount of inductance are charged & discharge in parallel during the switched-on & switched-off period respectively. Simulation is done in Matlab/Simulink and results are presented which show that voltage stresses on the proposed converters are less as compared to conventional boost converter. The graph between Voltage gain & duty ratio for the boost converter and the proposed converters illustrates that, the proposed converter achieve high step up voltage gain.

REFERENCES

1. Lung Sheng Yang, Tsorng Juu Liang, "Transformer less DC-DC Converters With High Step-Up Voltage Gain", IEEE Trans. Ind. Electron., vol. 56, no. 8, Aug. 2009.
2. B B. Bryant and M. K. Kazimierczuk : "Voltage-loop power-stage transfer functions with MOSFET delay for boost PWM converter operating in CCM", IEEE Trans. Ind. Electron., vol. 54, no. 1, pp. 347–353, Feb. 2007.
3. X. Wu, J. Zhang, X. Ye, and Z. Qian : "Analysis and derivations for a family ZVS converter based on a new active clamp ZVS cell", IEEE Trans. Ind. Electron., vol. 55, no. 2, pp. 773–781, Feb. 2008
4. D. C. Lu, K. W. Cheng, and Y. S. Lee : "A single-switch continuous conduction- mode boost converter with reduced reverse-recovery and switching losses", IEEE Trans. Ind. Electron., vol. 50, no. 4, pp. 767–776, Aug. 2003.
5. Hrishitosh Bisht, R. K. Singh, "A Novel Simulation Method Using State flow for DC-DC converters", 2012 2nd International Conference on Power, Control and Embedded Systems.
6. R. J. Wai, C.Y. Lin, R.Y.Duan, and Y. R. Chang, "High-efficiency power conversion system for kilowatt-level stand-alone generation unit with low input voltage," IEEE Trans. ind. Electron., vol. 55, no. 10, pp. 3702-3714, Oct. 2008.

7. F. L. Luo and H. Ye, "Positive output multiple-lift push-pull switched capacitor Luo-converters", IEEE Trans. Ind. Electron., vol. 51, no. 3, pp. 594–602, Jun. 2004.
8. F.L. Luo, "Six self-lift DC–DC converters, voltage lift technique", IEEE Trans. Ind. Electron., vol. 48, no. 6, pp. 1268–1272, Dec. 2001.
9. R. Gules, L. L. Pfitscher, and L. C. Franco, "An interleaved boost DC–DC converter with large conversion ratio", in Proc. IEEE ISIE, 2003, pp. 411–416.