



BULLKID

BULky and Low-threshold
Kinetic Inductance Detectors



Istituto Nazionale di Fisica Nucleare

Marco Vignati, INFN Roma

on behalf of the BULLKID collaboration

The Magnificent CEvNS Workshop, Chicago, 3 Nov. 2018

Motivation: Dark Matter

Low-mass Dark Matter ($< 1 \text{ GeV} / c^2$) is unexplored by present WIMP Dark Matter experiments.

US Cosmic Vision 2017 1707.04591

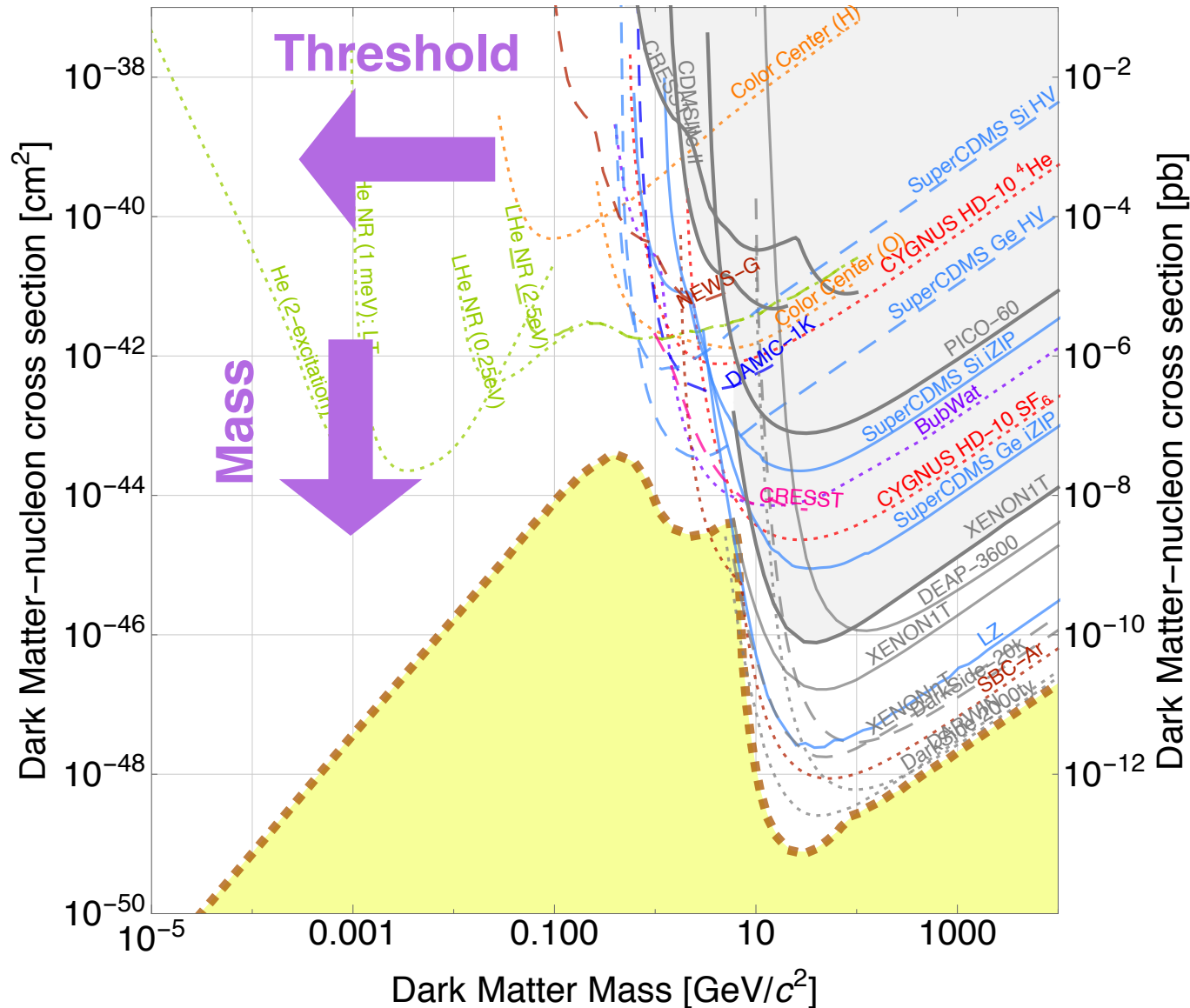

Motivation: CE ν NS

- Neutrino coherent scattering on nuclei (CE ν NS), recently discovered by COHERENT [Akimov et al, *Science* 357 (2017) 1123], is a new probe for new physics via precision measurements of the cross-section.
- Aside nuclear reactors or spallation sources, lower energy sources, such as the monochromatic ^{51}Cr (GALLEX) might be explored.

Counts above threshold at 1 m from source

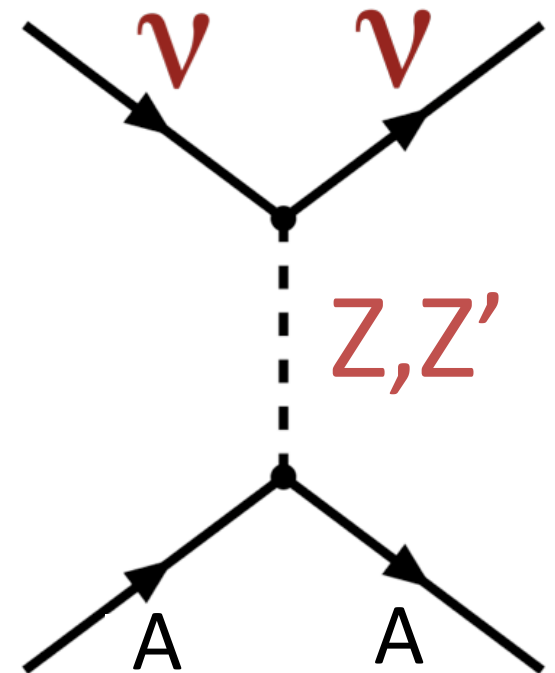
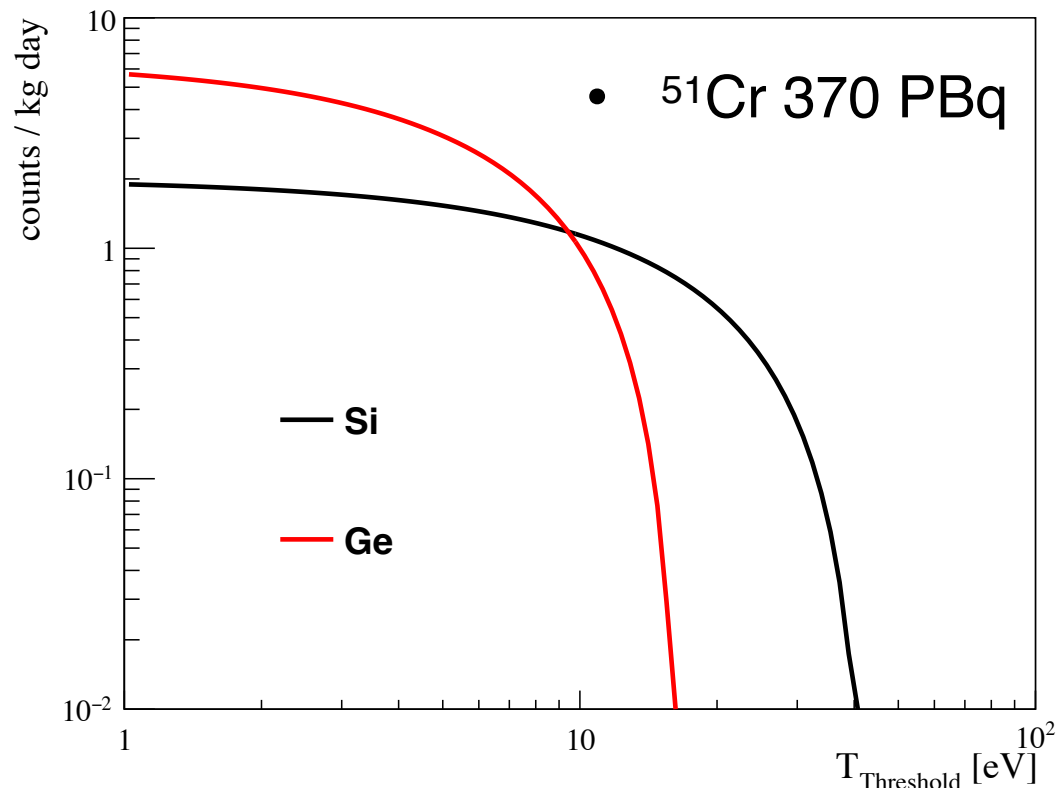

Detector R&D

- Would like a ~ 1 kg detector with an energy threshold < 20 eV.
- Two ongoing R&Ds on **arrays of small cryogenic calorimeters**:
 - ▶ **ν -cleus** (Germany), based on TES sensors
R. Strauss et al, Eur. Phys. J. C77 (2017) 506
 - ▶ **Ricochet** (France-USA), based on NTD sensors
J. Billard et al, J. Phys. G44 (2017) 105101.
 - ▶ Both granted in 2018 by the European Research Council
- Challenges:
 - ▶ Scale single detector units to large arrays (multiplexing)
 - ▶ Mass increase of the single detector unit.

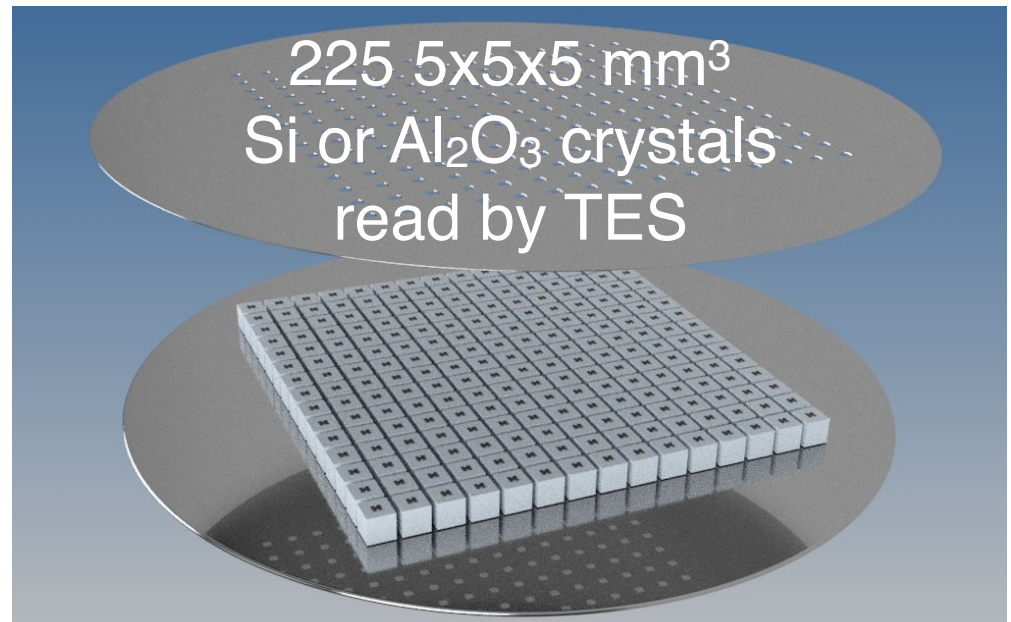

Kinetic Inductance Detectors (KIDs)

BULLKID (INFN 2019-20 Grant) proposes KIDs as an alternative to TES and NTD sensors

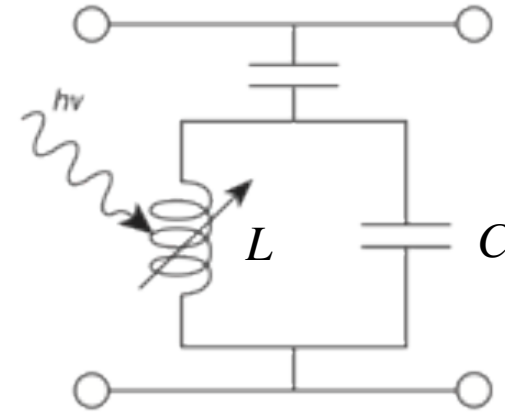
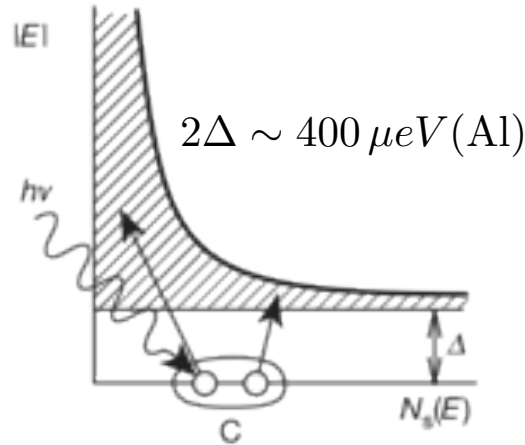

Cooper pairs (cp) in a superconductor act as an inductance (L).
Absorbed photons or phonons change cp density and L .

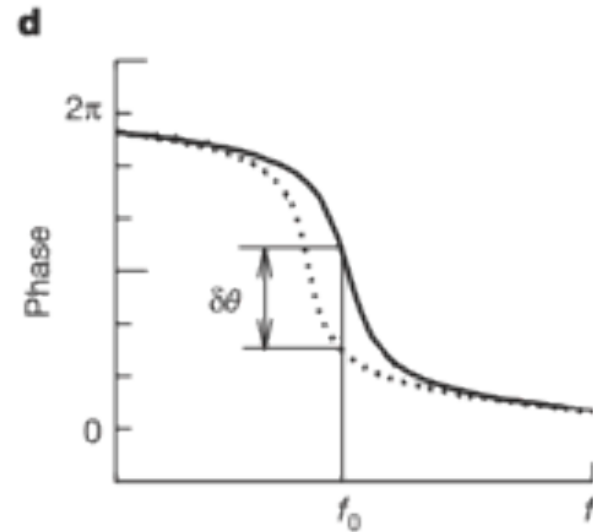
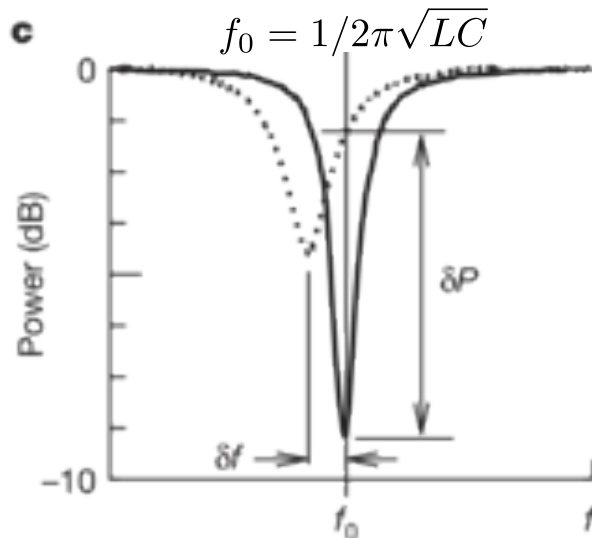

High quality factor (Q) resonant circuit biased with a microwave (GHz):
signal from amplitude and phase shift.

Day et al., Nature 425 (2003) 817

KID signal

1. Frequency sweep to measure the transmission S_{21} past the resonator:
2. Determine the resonant frequency and bias the detector at that frequency.
3. Measure **Phase** and **Amplitude** Modulation of the wave transmitted past the resonator. Usually only the phase readout is used.

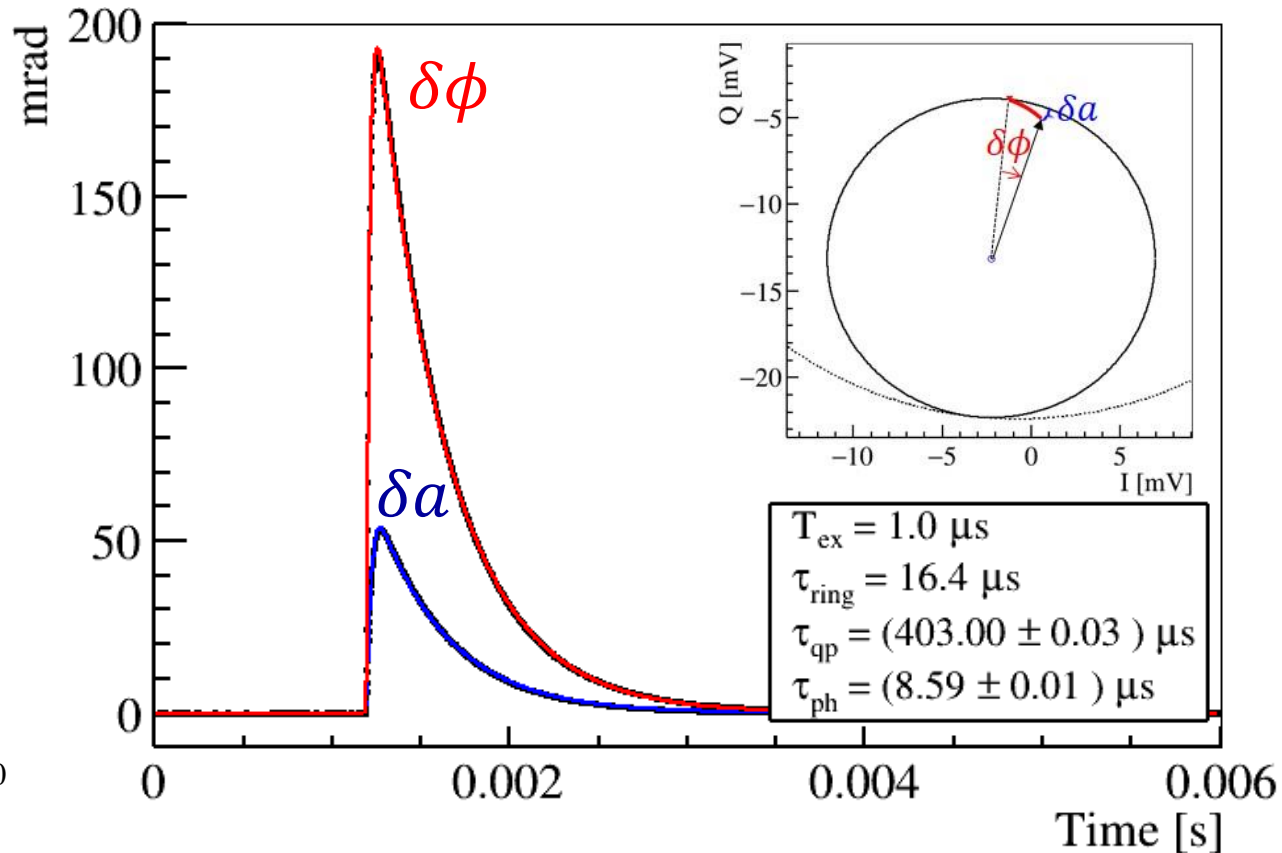
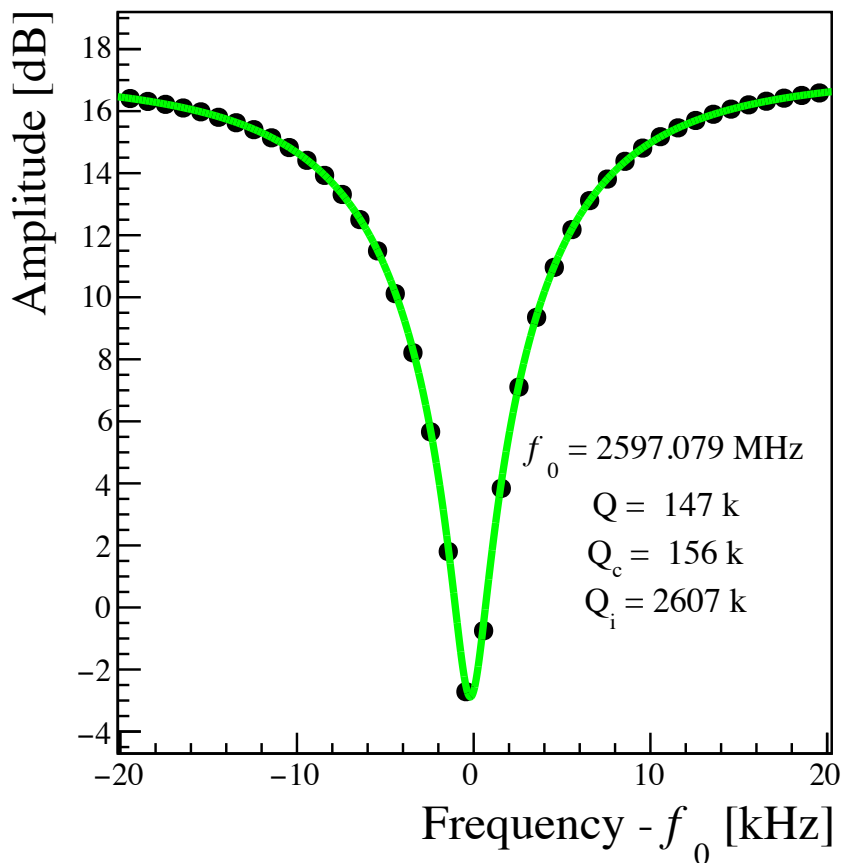

KID Multiplexing

Different resonators can be coupled to the same feedline with slightly different resonant frequencies.

Resonant frequency modified via the capacitor (C) pattern of the circuit.

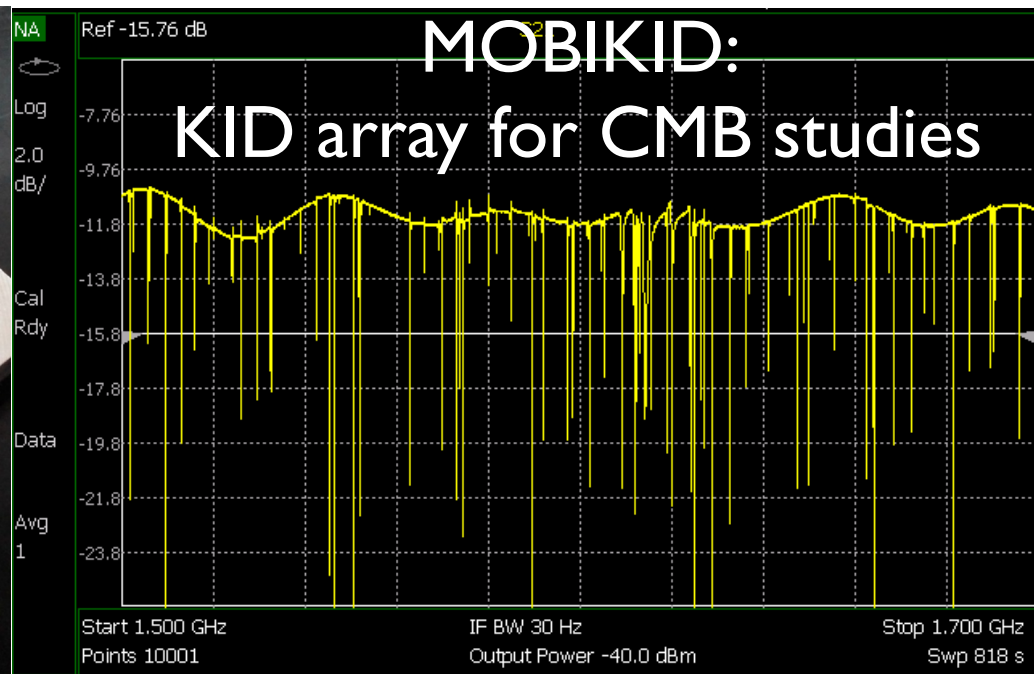
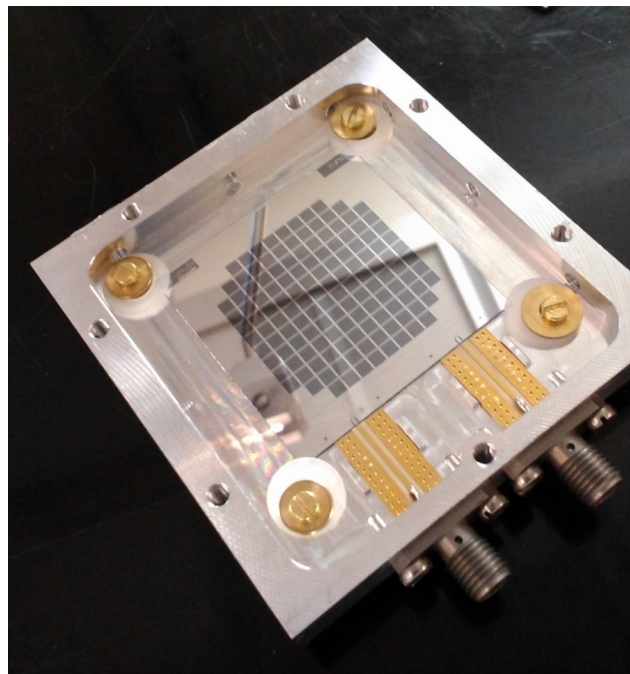
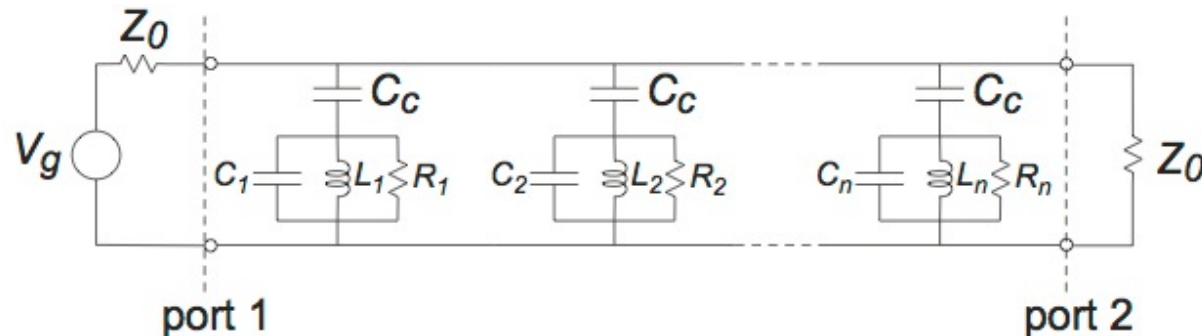

Multiplexing of 1000 KIDs with a single cryogenic amplifier demonstrated

Sensising “large” targets: CALDER

CALDER develops cryogenic light detectors for double β decay experiments.

GHz operation limits the maximum sensible area of KIDs to **few mm^2**

Kinetic inductance require superconductor thickness of **tens of nm**

Solution: **indirect detection mediated by phonons**

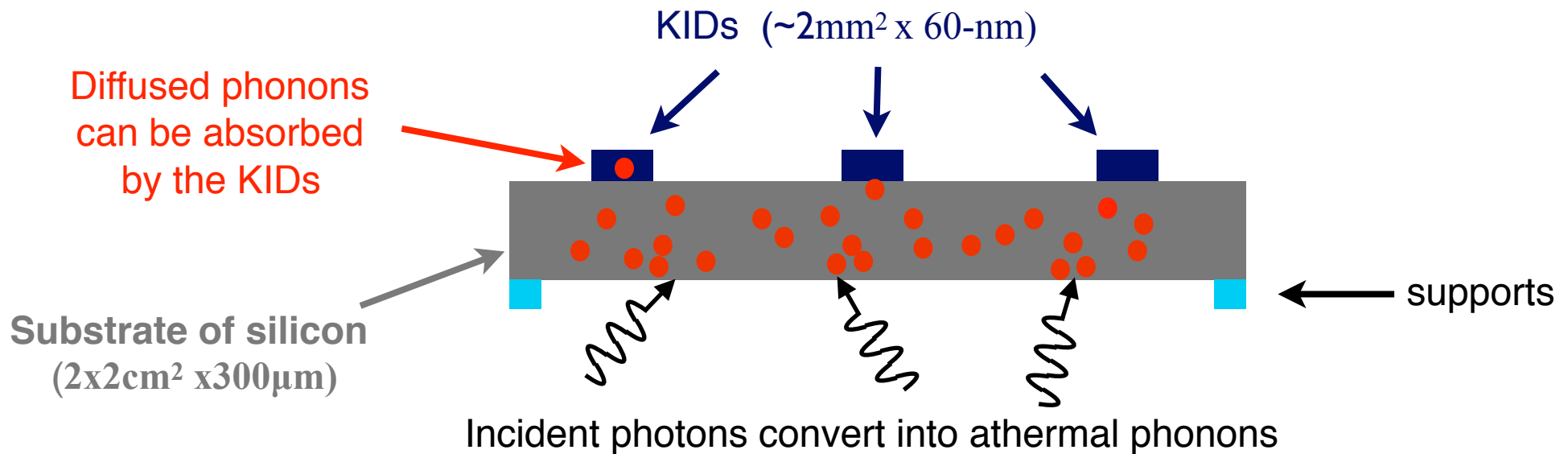

Challenge: collect as many phonons as possible

The smaller the number of pixels the better!

<http://www.roma1.infn.it/exp/calder/>

CALDER results

[L. Cardani, et al, SUST \(2018\)](#)

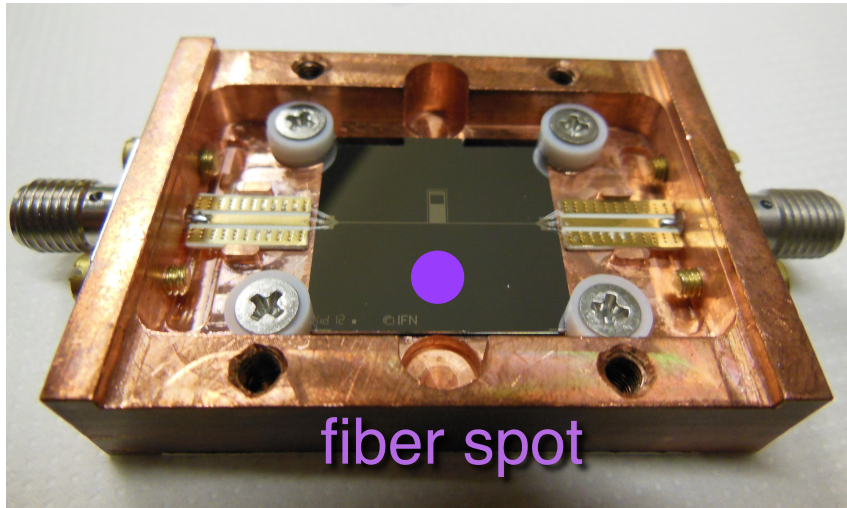

- Al(14)Ti(33)Al(30nm) resonator
- 2x2cm² x 350um Silicon substrate
- 25 eV RMS @ 0 eV
- Phonon $\epsilon \sim 10\%$

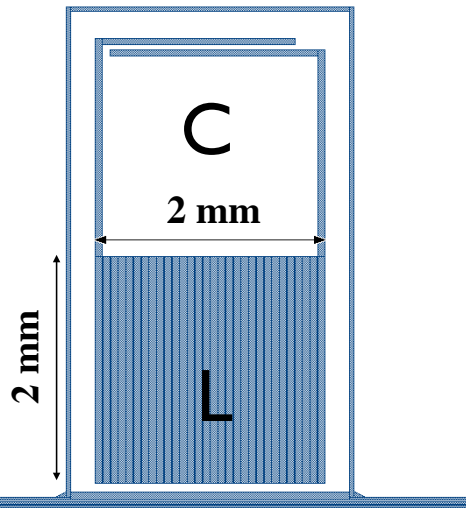

Scan with LED driven optical fiber

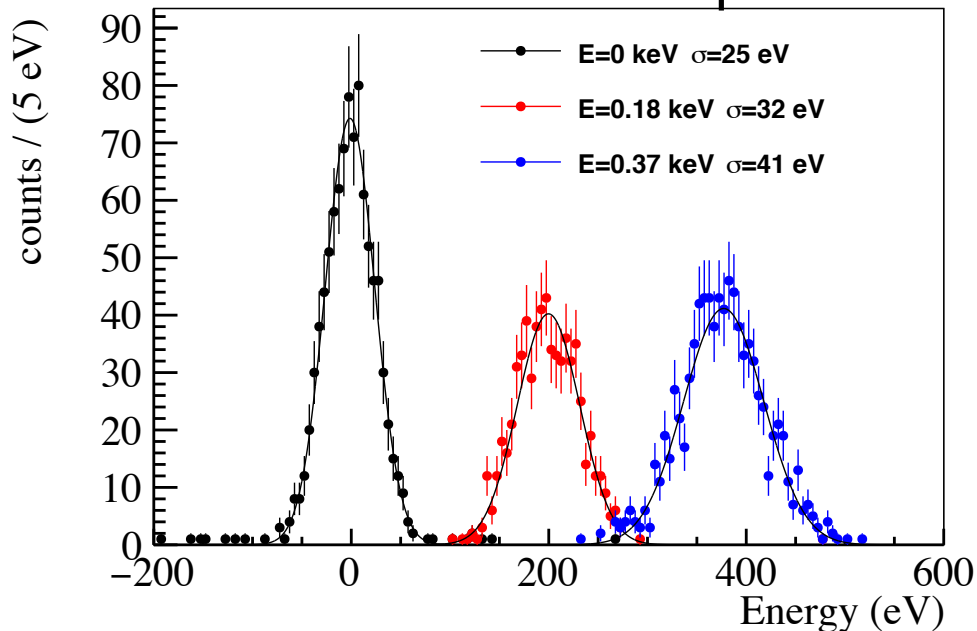

Self-calibrated with photon statistics

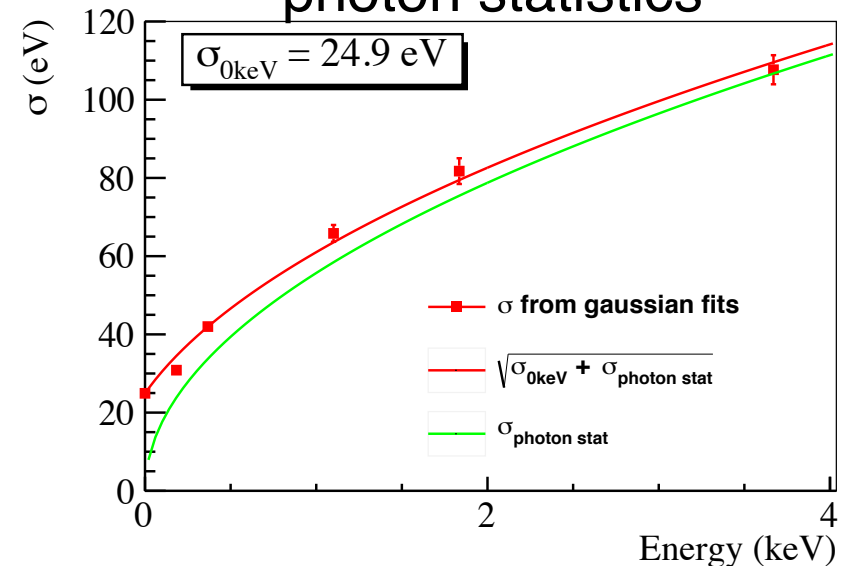

BULLKID single unit

BULLKID aims at a detector of athermal phonons created by nuclear recoils induced by Dark Matter or neutrino scattering.

Mass: To increase the detector mass we will fabricate KIDs on 5 mm thick instead of 300 μm wafers.

Threshold: To reach < 20 eVnr threshold we will act on the phonon absorption and on the KID sensitivity (25 eV σ demonstrated by CALDER).

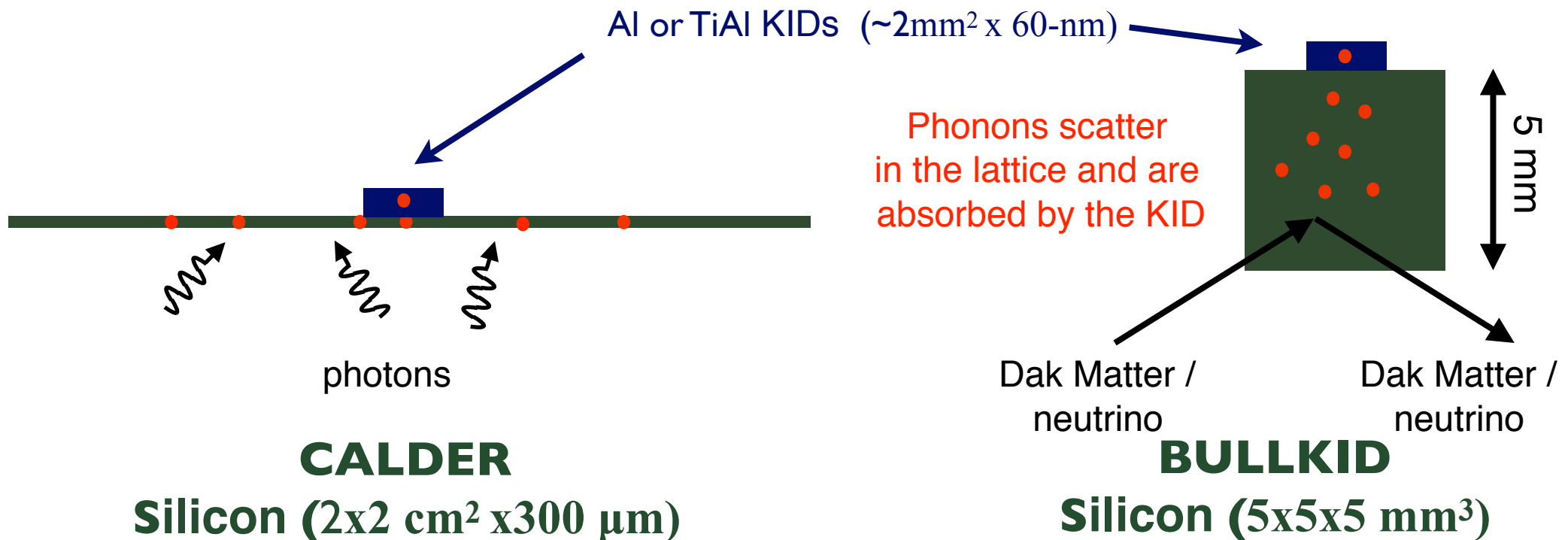

BULLKID array

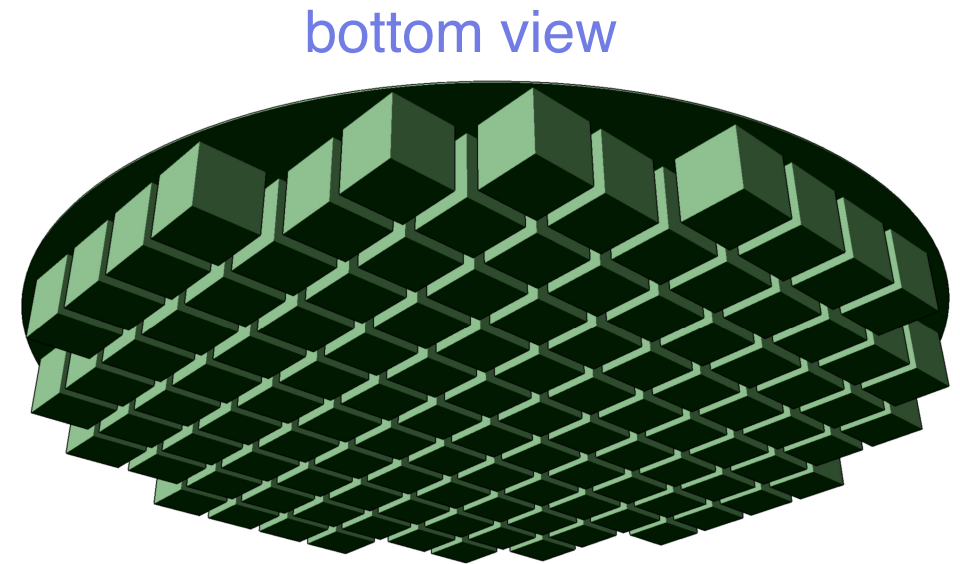
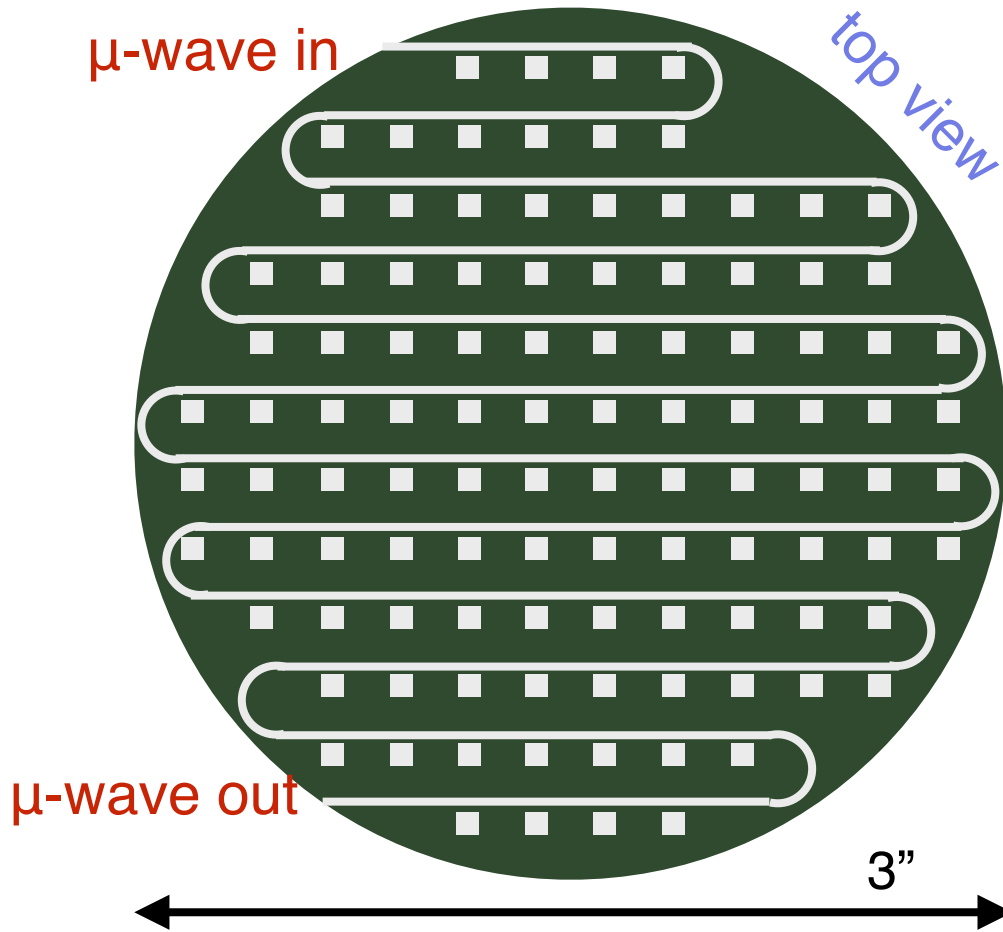

- We will deposit ~ 110 KIDs at once on top of a 3" wafer.
- The KIDs will be coupled to the same feedline for multiplexing.

- The wafer is diced from the bottom to create cubic voxels of $5 \times 5 \times 5 \text{ mm}^3$.
- ~ 110 cubic voxels of $5 \times 5 \times 5 \text{ mm}^3$ can be exploited.
- 0.29 g / voxel
- 32 g total target mass.

Phonon x-talk and silicon dicing

- The smaller the surface thickness the smaller the phonon leak in nearby voxels
- MC Phonon simulations ongoing to quantify the leak.

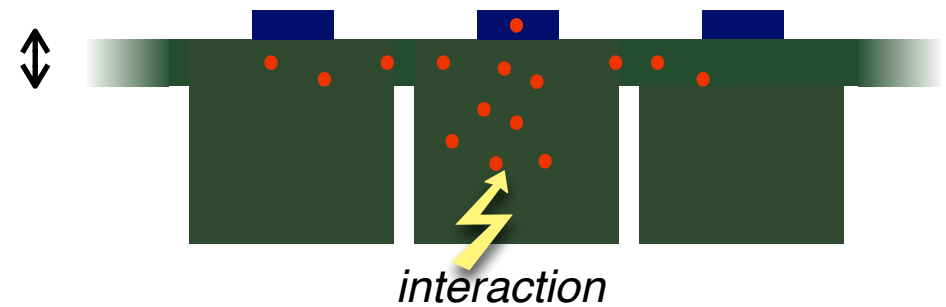

Dicing technology exists and is being tuned to our needs

Material	Germanium
Tile size (mm ³)	30×10×2
Blade type	G1A 320
Blade width (μm)	250
Blade rotation (rpm)	3000
Blade speed (mm/s)	0.1
Groove depth (μm)	1550
Number of grooves	9×28
Groove step (mm)	1
Primary radius of curvature along y (m)	40
QM radius of curvature (m)	95.6
Angular bandpass (arcsec)	4.3

R. Camattari, A Battelli,
V. Bellucci, V. Guidi
Exp. Astron. 37 (2014) 1

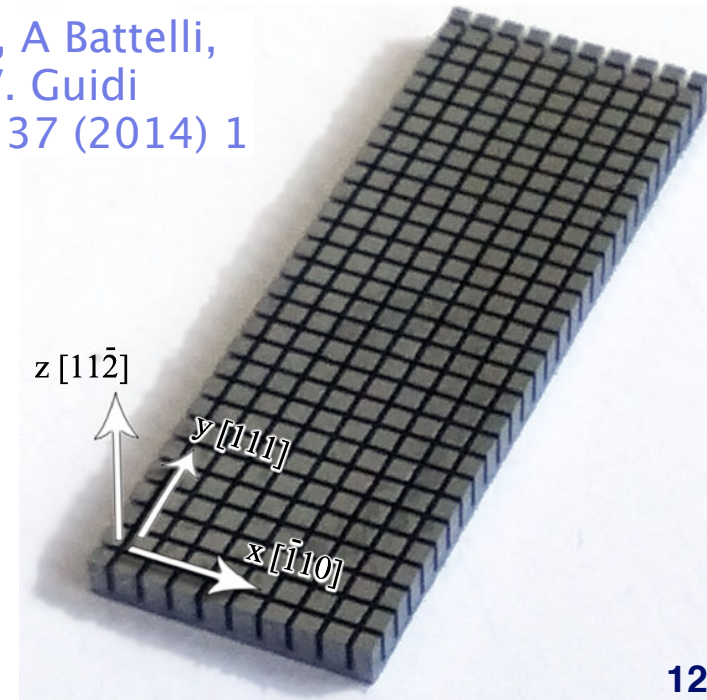

KID superconductor (R&D started by CALDER)

$$\Delta E \propto \frac{T_C}{\epsilon \sqrt{QL}}$$

	Al	Ti+TiN	Ti+Al	Granular Al	W-Al
T_C [K]	1.2	0.5-0.8	0.6-0.9	1-2	0-1.2
L [pH/square]	0.35	6?	1.2	10-1000	30?
Q_{max}	$>10^5$	10^4	$>10^5$	$>10^6$?
Phonon ϵ	10%	low?	10%	10%	?
τ_{qp} [μ s]	100-1000	10-100	100-1000	10-30	?
Fabrication	IFN-CNR	CNR/FBK	CSNSM Neel-CNRS	KIT	MPI-Munich
Status	Completed	Challenging	Ongoing	Completed	Started
ΔE [eV]	50-100	-	25	150	?

Detector array

BULLKID: one 3" 5mm thick wafer

- 0.29 g / voxel
- 110 voxels / 3" wafer
- 32 g / 3" wafer.

Possible experiment with 1 kg mass:

- ▶ Maybe 4" or 6" wafer.
- ▶ Maybe increase thickness to 1 cm (phonon absorption to be verified).
- ▶ Stack a number of wafers to reach the total target mass.
- ▶ No inert material between inner voxels:
bkg. id. and fiducialization.

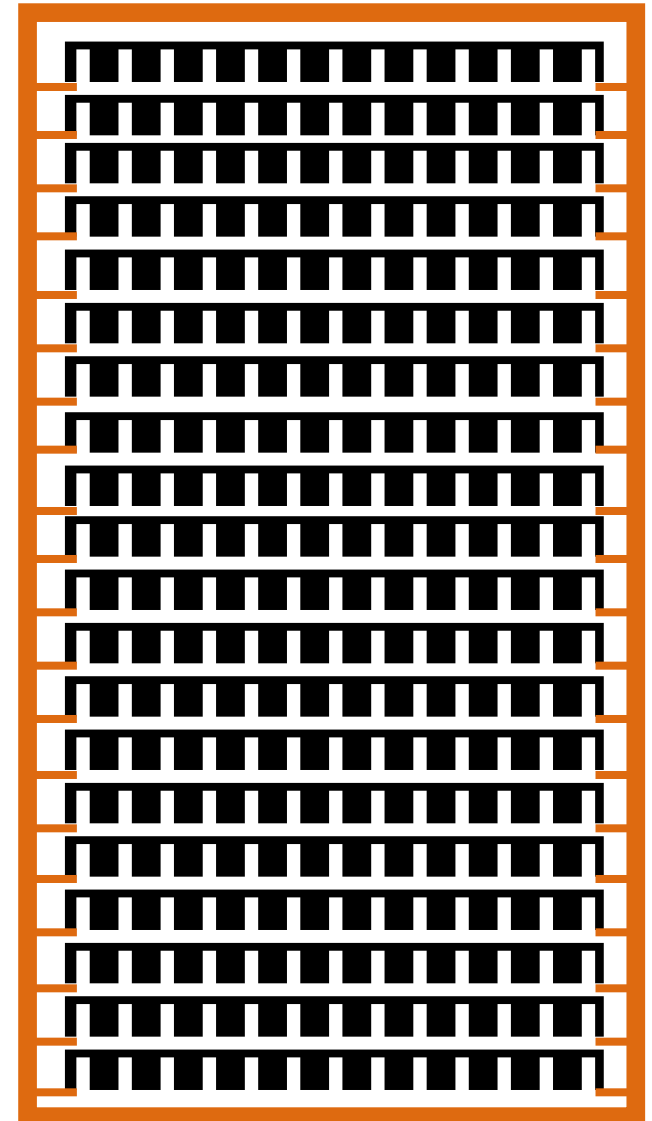

BULLKID collaboration is forming and starting activities, we are open to collaborations!



Istituto Nazionale di Fisica Nucleare:

*L. Cardani, N. Casali, A. Cruciani,
V. Pettinacci and M. Vignati (PI).*



Zaragoza University:

M. Martinez



Consiglio Nazionale delle Ricerche

G. Pettinari.



Ferrara University:

V. Guidi



Genova University

S. Di Domizio.



CSNSM - CNRS/IN2P3

H. Le Sueur



Institut Néel - CNRS

M. Calvo, J. Goupy, A. Monfardini



BACKUP

Impact of threshold

- Threshold = $\Delta E \times 5$, with TiAl implies 125 eV, too large for BULLKID.
- Phonon efficiency is expected to increase substantially in BULLKID because of the new geometry (no leak on supports, less surface scatterings) .
- TiAl has margin for improvement and W-Al is potentially even better thanks to the lower T_c .

Neutrino source experiments require threshold < 20 eV

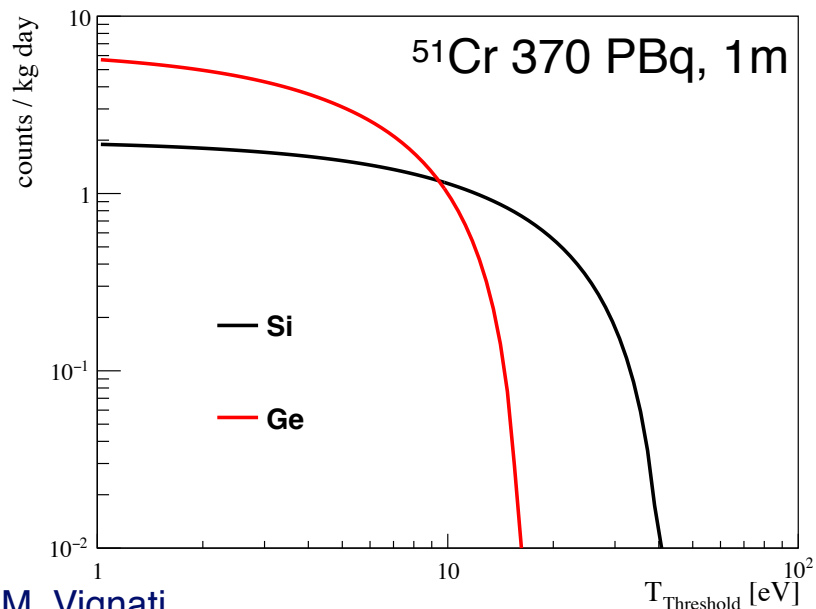

Reactor experiments, because of the larger neutrino energy, could be performed even with a threshold of 100 eV

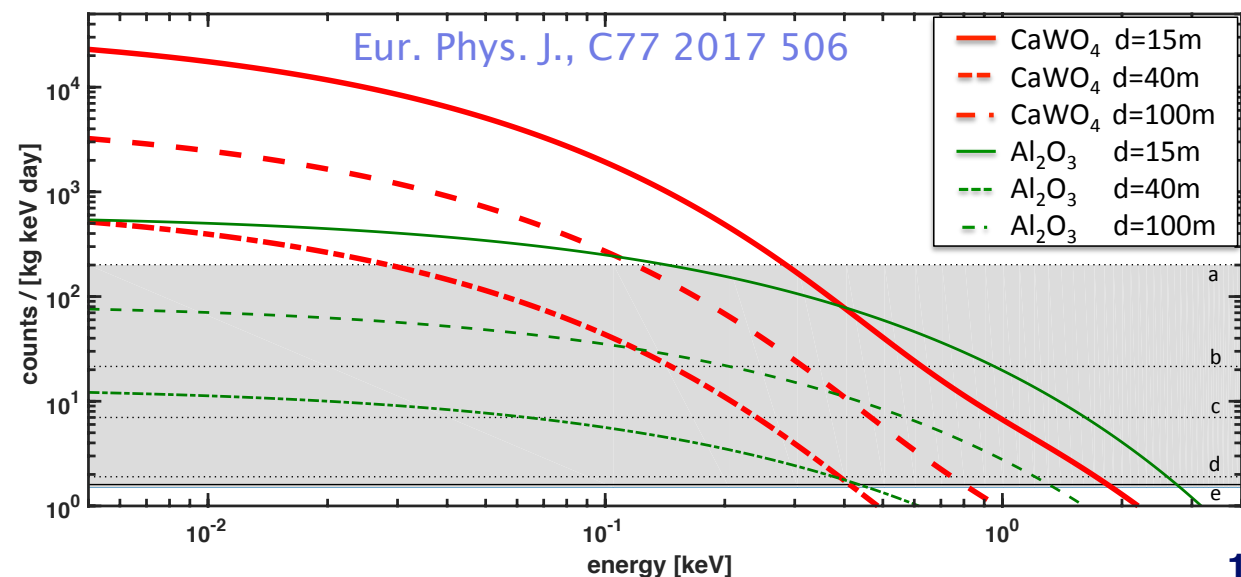

CALDER LAB



Heterodyne readout development

- So far using an electronics able to handle up to 12 KIDs in parallel.
- We are developing a custom FPGA firmware on top of the ROACH2 opensource hardware and software board.
 - ▶ Goal: 100 KIDs in parallel.
- Developed by a wide (mostly astro-) community.

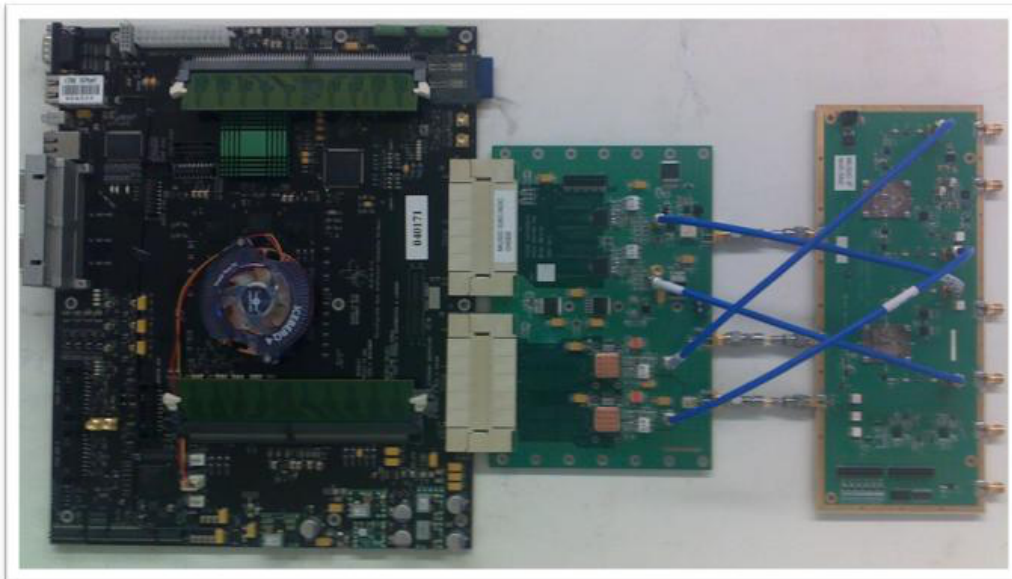

ROACH readout system

FPGA board (Virtex6) for signal processing

On-board PowerPc for FPGA control

16-bit 1000Msps dual DAC

14-bit 400Msps dual ADC

4x 10Gbe interfaces for data streaming

Up/down conversion w clock-distribution board