

This article was downloaded by: [Michigan State University]

On: 04 February 2015, At: 20:41

Publisher: Taylor & Francis

Informa Ltd Registered in England and Wales Registered Number: 1072954

Registered office: Mortimer House, 37-41 Mortimer Street, London W1T 3JH, UK



Philosophical Magazine Series 6

Publication details, including instructions for authors and subscription information:

<http://www.tandfonline.com/loi/tphm17>

XLVII. On rays of positive electricity

J.J. Thomson M.A. F.R.S.

Published online: 16 Apr 2009.

To cite this article: J.J. Thomson M.A. F.R.S. (1907) XLVII. On rays of positive electricity , Philosophical Magazine Series 6, 13:77, 561-575, DOI:

[10.1080/14786440709463633](https://doi.org/10.1080/14786440709463633)

To link to this article: <http://dx.doi.org/10.1080/14786440709463633>

PLEASE SCROLL DOWN FOR ARTICLE

Taylor & Francis makes every effort to ensure the accuracy of all the information (the "Content") contained in the publications on our platform. However, Taylor & Francis, our agents, and our licensors make no representations or warranties whatsoever as to the accuracy, completeness, or suitability for any purpose of the Content. Any opinions and views expressed in this publication are the opinions and views of the authors, and are not the views of or endorsed by Taylor & Francis. The accuracy of the Content should not be relied upon and should be independently verified with primary sources of information. Taylor and Francis shall not be liable for any losses, actions, claims, proceedings, demands, costs, expenses, damages, and other liabilities whatsoever or howsoever caused arising directly or indirectly in connection with, in relation to or arising out of the use of the Content.

This article may be used for research, teaching, and private study purposes. Any substantial or systematic reproduction, redistribution, reselling, loan,

sub-licensing, systematic supply, or distribution in any form to anyone is expressly forbidden. Terms & Conditions of access and use can be found at <http://www.tandfonline.com/page/terms-and-conditions>

THE
LONDON, EDINBURGH, AND DUBLIN
PHILOSOPHICAL MAGAZINE
AND
JOURNAL OF SCIENCE.

[SIXTH SERIES.]

MAY 1907.

XLVII. *On Rays of Positive Electricity.*

By J. J. THOMSON, M.A., F.R.S.*

IN 1886 Goldstein discovered that when the cathode in a discharge-tube is perforated, rays pass through the openings and produce luminosity in the gas behind the cathode; the colour of the light depends on the gas with which the tube is filled and coincides with the colour of the velvety glow which occurs immediately in front of the cathode.

Fig. 1.

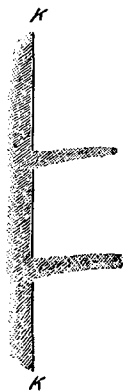

The appearance of these rays is indicated in fig. 1, the anode being to the left of the cathode KK. Since the rays appeared through narrow channels in the cathode, Goldstein called them "Kanalstrahlen": now that we know more about their nature, "positive rays" would, I think, be a more appropriate name. Goldstein showed that a magnetic force which would deflect cathode rays to a very considerable extent was quite without effect on the "Kanalstrahlen." By using intense magnetic fields, W. Wien showed that these rays could be deflected, and that the deflexion was in the opposite direction to that of the cathode rays, indicating that these rays carry a positive charge of electricity. This was confirmed by measuring the electrical charge received by a vessel into which the rays passed through a small hole, and also by observing the direction in which

* Communicated by the Author.

they are deflected by an electric force. By measuring the deflexions under magnetic and electric forces, Wien found by the usual methods the value of e/m and the velocity of the rays. He found for the maximum value of e/m the value of 10^4 , which is the same as that for an atom of hydrogen in the electrolysis of solutions. A valuable summary of the properties of these rays is contained in a paper by Ewers*.

As these rays seem the most promising subjects for investigating the nature of positive electricity, I have made a series of determinations of the values of e/m for positive rays under different conditions. The results of these I will now proceed to describe.

Apparatus.

Screen used to detect the rays.—The rays were detected and their position determined by the phosphorescence they produced on a screen at the end of the discharge-tube. A considerable number of substances were examined to find the one which would fluoresce most brightly under the action of the rays. As the result of these trials, Willemite was selected. This was ground to a very fine powder and dusted uniformly over a flat plate of glass. Considerable trouble was found in obtaining a suitable substance to make the powder adhere to the glass. All gums &c. when bombarded by the rays are liable to give off gas; this renders them useless for work in vacuum-tubes. The method finally adopted was to smear a thin layer of “water-glass” (sodium-silicate) over the glass plate, and then dust the powdered Willemite over this layer and allow the water-glass to dry slowly before fastening the plate to the end of the tube.

The form of tube adopted is shown in fig. 2. A hole is bored through the cathode, and this hole leads to a very fine tube F. The bore of this tube is made as fine as possible so as to get a small well-defined fluorescent patch on the screen. These tubes were either carefully made glass tubes, or else the hollow thin needles used for hypodermic injections, which I find answer excellently for this purpose. After getting through the needle, the positive rays on their way down the tube pass between two parallel aluminium plates A, A. These plates are vertical, so that when they are maintained at different potentials the rays are subject to a horizontal electric force, which produces a horizontal deflexion of the patch of light on the screen. The part of the tube containing the parallel aluminium plates is narrowed as much as possible, and passes between the poles P, P of a powerful electromagnet of the Du Bois type. The poles of this magnet

* *Jahrbuch der Radioaktivität*, iii. p. 291 (1906).

are as close together as the glass tube will permit, and are arranged so that the lines of magnetic force are horizontal and at right angles to the path of the rays. The magnetic force produces a vertical deflexion of the patch of phosphorescence on the screen. To bend the positive rays it is necessary to use strong magnetic fields, and if any of the lines of force were to stray into the discharge-tube in front

Fig. 2.

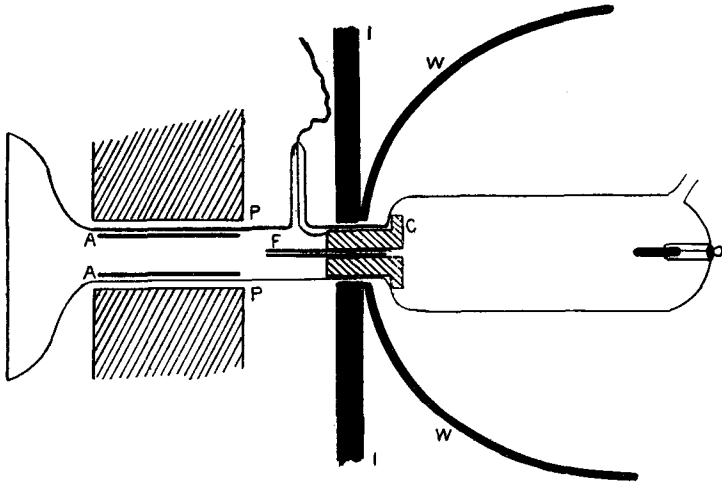

of the cathode, they would distort the discharge in that part of the tube. This distortion might affect the position of the phosphorescent patch on the screen, so that unless we shield the discharge-tube we cannot be sure that the displacement of the phosphorescence is entirely due to the electric and magnetic fields acting on the positive rays after they have emerged from behind the cathode.

To screen off the magnetic field, the tube was placed in a soft iron vessel *W* with a hole knocked in the bottom, through which the part of the tube behind the cathode was pushed. Behind the vessel a thick plate of soft iron with a hole bored through it was placed, and behind this again as many thin plates of soft iron, such as are used for transformers, as there was room for were packed. When this was done it was found that the magnet produced no perceptible effect on the discharge in front of the cathode.

The object of the experiments was to determine the value of e/m by observing the deflexion produced by magnetic and electric fields. When the rays were undeflected they produced a bright spot on the screen ; when the rays passed

through electric and magnetic fields the spot was not simply deflected to another place, but was drawn out into bands or patches, sometimes covering a considerable area. To determine the velocity of the rays and the value of e/m , it was necessary to have a record of the shape of these patches. This might have been done by substituting a photographic plate for the Willemite screen. This, however, was not the method adopted, as, in addition to other inconveniences, it involves opening the tube and repumping for each observation, a procedure which would have involved a great expenditure of time. The method actually adopted was as follows:—The tube was placed in a dark room from which all light was carefully excluded, the tube itself being painted over so that no light escaped from it. Under these circumstances the phosphorescence on the screen appeared bright and its boundaries well defined. The observer traced in Indian ink on the outside of the thin flat screen the outline of the phosphorescence. When this had been satisfactorily accomplished the discharge was stopped, the light admitted into the room, and the pattern on the screen transferred to tracing-paper; the deviations were then measured on these tracings.

Calculation of the Magnetic and Electric Deviation of the Rays.

If we assume the electric field to be uniform between the plates and zero outside them, then we can easily show that x , the horizontal deflexion of a ray whose charge is e , mass m , and velocity v , is given by the equation

$$x = \frac{1}{2}X \frac{e}{mv^2} l(l + 2d),$$

where X is the force between the plates, l the length of path of the rays between the plates, and d the distance of the screen from the nearer end of the parallel plates.

To find the deflexion due to the magnetic field, we have, if ρ is the radius of curvature of the path at a point where the magnetic force is H ,

$$\frac{mv^2}{\rho} = Hev,$$

or

$$\frac{1}{\rho} = \frac{e}{mv} H.$$

If y is the vertical displacement of the particle, we have

$$\frac{1}{\rho} = \frac{d^2y}{dz^2} \text{ approximately,}$$

where z is measured along the path of the ray. Hence

$$\frac{d^2y}{dz^2} = \frac{e}{mv} H ;$$

$$y = \frac{e}{mv} \left[\int_0^{l+d} \int_0^z H dz \right]. \dots (1)$$

In these strong fields there are considerable variations of H along the path, so that to calculate the integrals we should have to map out the value of H along the path of the ray. This would be a very laborious process, and it was rendered unnecessary by the following simple method, which, while not involving anything like the labour of the direct method, gives much more accurate results. The method is shown in fig. 3.

Fig. 3.

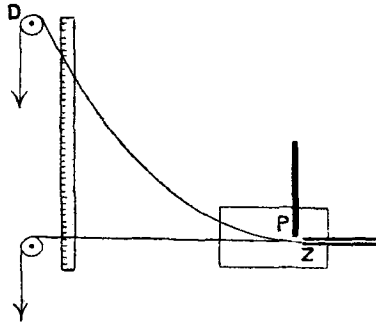

The part of the tube through which the rays pass was cut off, and a metal rod placed so that its tip Z coincided with the aperture of the narrow tube through which the positive rays had emerged. A very fine wire soldered to the end of this tube passed over a light pulley, and carried a weight at the free end. The pulley was supported by a screw by means of which it could be raised or lowered; a known current passed through the wire, entering it at Z and leaving it through the pulley. The pulley was first placed so that the path of the stretched wire when undeflected by a magnetic field coincided with the path of the undeflected rays. A vertical scale whose edge was at the same distance from the

opening through which the rays emerge as the screen on which the phosphorescence had been observed, was placed just behind the wire, and was read by a reading microscope with a micrometer eyepiece. When the magnetic field was put on, the wire was deflected; and if T is the tension of the wire, ρ the radius of curvature into which it is bent, i the current through the wire,

$$\frac{T}{\rho} = Hi;$$

or, if y_1 is the vertical displacement of the wire,

$$\frac{d^2 y_1}{dz^2} = \frac{i}{T} \cdot H.$$

Now if $\frac{dy_1}{dz} = 0$ when $z = 0$ we have, if y_1 is the displacement of the wire at the scale,

$$y_1 = \frac{i}{T} \int_0^l \int_0^z H dz. \quad \dots \quad (2)$$

Hence, comparing (1) and (2) we have

$$\frac{y}{y_1} = \frac{\frac{e}{mv}}{\frac{i}{T}}, \quad \dots \quad (3)$$

a relation from which the magnetic force is eliminated. To ensure that the tangent to the wire is horizontal when $z = 0$, the following method is used. P is a chisel-edge carried by a screw and placed about 1 mm. in front of the fixed end of the wire; this is adjusted so that when the magnetic field is not on the wire just touches the edge: this can be ascertained by making the contact with the wire complete an electric circuit in which a bell is placed. When the magnetic field is put on the wire is pulled off from the edge, and the tangent at $z = 0$ is no longer horizontal; it can, however, be brought horizontal by raising or lowering the pulley D until the wire is again in contact with P, which can be ascertained again by the ringing of the bell. Then y_1 is the vertical distance between the point where the wire now crosses the edge of the scale and the point where it crossed it before the magnetic field was put on. Since y , y_1 , i , and T can easily be measured, equation (3) gives us the value of e/mv , while the deflexion under the electric force gives the value of e/mv^2 .

If y is the vertical displacement of the patch of phosphorescent light on the screen produced by the magnetic field, x the horizontal displacement due to the electrostatic field, we see that

$$y = \frac{y_1}{(i/T)} \frac{e}{mv} = B \frac{e}{mv},$$

$$x = A \frac{e}{mv^2},$$

where A and B are constants depending on the position of the screen and the magnitudes of the electric and magnetic forces. These quantities can be calculated by means of the equations just given.

Since

$$\frac{y}{x} = \frac{B}{A} v,$$

$$\frac{y^2}{x} = \frac{B^2}{A} \frac{e}{m}.$$

We see that if the pencil is made up of rays having a constant velocity but having all values of e/m up to a maximum value, the spot of light will be spread out by the magnetic and electric fields into a straight line extending a finite distance from the origin. While if it is made up of two sets of

Fig. 4.



Fig. 5.



rays, one having the velocity v_1 the other the velocity v_2 , the spot will be drawn out into two straight lines as in fig. 4.

If e/m is constant and the velocities have all values up to a maximum, the spot of light will be spread out into a portion of a parabola, as indicated in fig. 5.

We shall later on give examples of each of these cases.

The discharge was produced by means of a large induction-coil, giving a spark of about 50 cm. in air, with a vibrating make and break apparatus. Many tubes were used in the course of the investigation, the dimensions of these varied slightly. The distance of the screen from the hole from which the rays emerged was about 9 cm., the length of the parallel plates about 3 cm., and the distance between them .3 cm.

Properties of the Positive Rays when the Pressure is not exceedingly low.

The appearance of the phosphorescent patch after deflexion in the electric and magnetic fields depends greatly upon the pressure of the gas. I will begin by considering the case when the pressure is comparatively high, say of the order of $1/50$ of a millimetre. At these pressures, though the walls of the tube in front of the cathode were covered with bright phosphorescence and the dark space extended right up to the walls of the tube and was several centimetres thick, traces of the positive column could be detected in the neighbourhood of the anode. I will first take the case where the tube was filled with air. Special precautions were taken to free the air from hydrogen; it was carefully dried, and a subsidiary discharge-tube having a cathode made of the liquid alloy of sodium and potassium was fused on to the main tube. When the discharge passes from such a cathode it absorbs hydrogen. The discharge was sent through this tube at the lowest pressure at which enough light was produced in the gas to give a visible spectrum, until the hydrogen lines disappeared and the only lines visible were those of nitrogen and mercury vapour. This pressure was a little higher than that used for the investigation of the positive rays, but a pump or two was sufficient to bring the pressure down to this value. The appearance of the phosphorescence on the screen when the rays were deflected by magnetic and electric forces separately and conjointly is shown in fig. 6.

The deflexion under magnetic force alone is indicated by vertical shading, under electric force alone by horizontal shading, and under the two combined by cross shading.

The spot of phosphorescence is drawn out into a band on either side of its original position. The upper portion, which is very much the brighter, is deflected in the direction which indicates that the phosphorescence is produced by rays having a positive charge; the lower portion (indicated by dots in the figure), which though faint is quite perceptible on the Willemite screen, is deflected as if *the rays carried a negative charge*. The length of the lower portion is somewhat shorter than that of the upper one, but is quite comparable with it. The intensity of the luminosity in the upper portion is at these pressures quite continuous; no abrupt variations such as would show themselves as bright patches could be detected, although, as will be seen later on, these make their appearance at lower pressures. Considering for the present the upper portion, the straightness of the edges shows that the velocity of the rays is approxi-

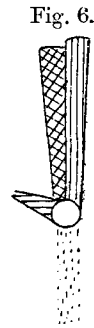

mately constant, while the values of e/m range from zero at the undeflected portion to the value approximately equal to 10^4 at the top of the deflected band. This value of e/m is equal to that for a charged hydrogen atom, and moreover there was no specially great luminosity in the positions corresponding to $e/m=10^4/14$ and $10^4/16$, the values for rays carried by nitrogen or oxygen atoms, though these places were carefully scrutinised. As hydrogen when present as an impurity in the tube has a tendency to accumulate near the cathode, the following experiment was tried to see whether the Kanalstrahlen were produced from traces of hydrogen in the tube. The discharge was sent through the tube in the opposite direction, *i. e.*, so that the perforated electrode was the anode, the electric and magnetic fields being kept on. When the discharge passed in this way there was of course no luminosity on the screen; on reversing the coil again so that the perforated electrode was the cathode, the luminosity flashed out instantly, presenting exactly the same appearance as it had done when the tube had been running for some time with the perforated electrode as cathode.

The fact that a spot of light produced by the undeflected positive rays is under the action of electric and magnetic forces drawn out into a continuous band was observed by W. Wien, who was the first to measure the deflexion of the positive rays under electric and magnetic forces. The values of e/m obtained from the deflexions of various parts of this band range continuously from zero, the value corresponding to the undeflected portion, to 10^4 , the value corresponding to those most deflected. Wien explained this by the hypothesis that the charged particles which make up the positive rays act as nuclei round which molecules of the gas through which the rays pass condense, so that very complex systems made up of a very large number of molecules get mixed up with the particles forming the positive rays, and that it is these heavy and cumbrous systems which give rise to that part of the luminosity which is only slightly deflected. I think that the constancy of the velocity of the rays, indicated by the straight edges of the deflected band, is a strong argument against this explanation, and that the existence of the negative rays is conclusive against it. These negatively electrified rays, which form the faintly luminous portion of the phosphorescence indicated in fig. 6, are not cathode rays. The magnitude of their deflexion shows that the ratio of e/m for these rays, instead of being as great as 1.7×10^7 , the value for cathode rays, is less than 10^4 . The particles forming these rays are thus comparable in size with those which form the positive rays. The existence of these negatively electrified rays suggests

at once an explanation, which I think is the true one, of the continuous band into which the spot of phosphorescence is drawn out by the electric and magnetic fields. The values of e/m which are determined by this method are really the mean values of e/m , while the particle is in the electric and magnetic fields. If the particles are for a part of their course through these fields without charge, they will not during this part of their course be deflected, and in consequence the deflexions observed on the screen, and consequently the values of e/m , will be smaller than if the particle had retained its charge during the whole of its career. Thus, suppose that some of the particles constituting the positive rays, after starting with a positive charge, get this charge neutralized by attracting to them a negatively electrified corpuscle: the mass of the corpuscle is so small in comparison with that of the particle constituting the positive ray, that the addition of the particle will not appreciably diminish the velocity of the positive particle. Some of these neutralized particles may get positively ionized again by collision, while others may get a negative charge by the adhesion to them of another corpuscle, and this process might be repeated during the course of the particle. Thus there would be among the rays some which were for part of their course unelectrified, at other parts positively electrified, and at other parts negatively electrified. Thus the mean value of e/m might have all values ranging from α , its initial value, to $-\alpha'$, where α' might be only a little less than α . This is just what we observe, and when we remember that the gas through which the rays are passing is ionized, and contains a large number of corpuscles, it is, I think, what we should expect.

At very low pressures, when there are very few ions in the gas, this continuous band stretching from the origin is replaced by discontinuous patches.

Positive Rays in Hydrogen.

In hydrogen, when the pressure is not too low, the brightness of the phosphorescent patch is greater than in air at the same pressure; the shape of the deflected phosphorescence is markedly different from that in air. In air, the deflected phosphorescence is usually a straight band, whereas in hydrogen the boundary of the most deflected side is distinctly curved and is concave to the undeflected position. The appearance of the deflected phosphorescence is indicated in fig. 7.

The result indicated in fig. 8, which was also obtained with hydrogen, shows that we have here a mixture of two bands, as indicated in fig. 4, the two bands being produced by carriers having different maximum values of e/m . The greatest value

of e/m obtained with hydrogen was the same as in air, 1.2×10^4 , the velocity was 1.8×10^8 cm./sec. The presence

Fig. 7.



Fig. 8.



of the second band indicates that mixed with these we have another set of carriers, for which the maximum value e/m is half that in the other band, *i. e.* 5×10^3 . The curvature of the boundary generally observed is due to the admixture of these two rays.

Positive Rays in Helium.

In helium the phosphorescence is bright and the deflected patch has in general the curved outline observed in hydrogen. I was fortunate enough, however, to find a stage in which



Fig. 9.

the deflected patch was split up into two distinct bands, as shown in fig. 9. The maximum value of e/m in the band *a* was 1.2×10^4 , the same as in air and hydrogen, and the velocity was 1.8×10^8 ; while the maximum value of e/m in band *b* was almost exactly one quarter of that in *a* (*i. e.* 2.9×10^3). As the atomic weight of helium is four times that of hydrogen, this result indicates that the carriers which produce the band *b* are atoms of helium. This result is interesting because it is the only case (apart from hydrogen) in which I have found values of e/m corresponding to the atomic weight of the gas; and even in the case of helium, when the pressure in the discharge-tube is very low and the electric field very intense, the characteristic rays with $e/m = 2.9 \times 10^3$ sometimes disappear and, as in all the gases I have tried, we get two sets of rays, for one set of which $e/m = 10^4$ and for the other 5×10^3 .

Although the helium had been carefully purified from hydrogen, the band *a* (for which $e/m = 10^4$) was generally the brighter of the two. The case of helium is an interesting one; for the class of positive rays, known as the α rays, which are given off by radioactive substances, would *a priori* seem to consist most probably of helium, since helium is one of the products of disintegration of these substances. The value of e/m for these substances is 5×10^3 , where we have seen that in helium it is possible to obtain rays for which $e/m = 2.9 \times 10^3$. It is true that, at very low pressures and with strong electric

fields, we get rays for which $e/m = 5 \times 10^3$; but this is not a peculiarity of helium: all the gases which I have tried show exactly the same effect.

Argon.

When the discharge passed through argon, the effects observed were very similar to those occurring in air. The sides were perhaps a little more curved, and there was a tendency for bright spots to develop. The measurements of the electric and magnetic deflexion of these spots gave $e/m = 10^4$, the value obtained for other cases. There was no appreciable increase of luminosity in the positions corresponding to $e/m = 10^4/40$, as there would have been if an appreciable number of the carriers had been argon atoms.

Positive Rays in Gases at very low pressures.

As the pressure of the gas in the discharge-tube is gradually reduced, the appearance of the deflected phosphorescence changes: instead of forming a continuous band, the phosphorescence breaks up into two isolated patches; that part of the phosphorescence in which the deflexion was very small disappears, as also does the phosphorescence produced by the negatively electrified portion of the rays.

In the earlier experiments considerable difficulty was experienced in working at these very low pressures; for when the pressure was reduced sufficiently to get the effects just described, the discharge passed through the tube with such difficulty, that in a very few seconds after this stage was reached sparks passed from the inside to the outside of the tube, perforating the glass and destroying the vacuum. In spite of all precautions, such as earthing the cathode and all conductors in its neighbourhood, perforation took place too quickly to permit measurements of the deflexion of the phosphorescence.

This difficulty was overcome by taking advantage of the fact that, when the cathode is made of a very electropositive metal, the discharge passes with much greater ease than when the cathode is made of aluminium or platinum. The electropositive metals used for the cathode were (1) the liquid alloy of sodium and potassium which was smeared over the cathode, and (2) calcium, a thin plate of which was affixed to the front of the cathode. With these cathodes the pressure in the tube could be reduced to very low values without making the discharge so difficult as to lead to perforation of the tube by sparking, and accurate measurements of the position of the patches of phosphorescence could be obtained at leisure.

The results obtained at these low pressures are very interesting. Whatever kind of gas may be used to fill the

tube, or whatever the nature of the electrode, the deflected phosphorescence splits up into two patches. For one of these patches the maximum value of e/m is about 10^4 , the value for the hydrogen atom ; while the value for the other patch is

Fig. 10.

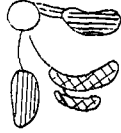

Hydrogen.

Fig. 11.



Helium.

Fig. 12.



o o
Air.

about 5×10^3 , the value for α particles or the hydrogen molecule. Examples of the appearance of this phosphorescence are given in figs. 10, 11, 12 ; in fig. 12 the magnetic force was reversed.

The differences in the appearance are due to differences in the pressure rather than to differences in the gas ; for at slightly higher pressures than that corresponding to fig. 12, the appearance shown in figs. 10 and 11 can be obtained in air. In all these cases the more deflected patch corresponds to a value of about 10^4 for e/m , while e/m for the less deflected patch is about 5×10^3 .

It will be noticed that in fig. 11 there is no trace in the helium tube of rays for which $e/m = 2.5 \times 10^3$, which were found in helium tubes at higher pressures ; at intermediate pressures there are *three* distinct patches in helium, for the first of which $e/m = 10^4$, for the second $e/m = 5 \times 10^3$, and for the third $e/m = 2.5 \times 10^3$ approximately. Helium is a case where there are characteristic rays—*i. e.*, rays for which $e/m = 10^4/M$, where M is the atomic weight of the gas, when the discharge potential is comparatively small, and not when, as at very low pressures, the discharge potential is very large. I think it very probable that if we could produce the positive rays with much smaller potential differences than those used in these experiments, we might get the characteristic rays for other gases. I am at present investigating with this object the positive rays produced when the perforated cathode is, as in Wehnelt's method, coated with lime, when a potential difference of 100 volts or less is able to produce positive rays. The interest of the experiments at very low pressures lies in the fact that in this case the rays are the same whatever gas may be used to fill the tube ; the characteristic rays of the gas disappear, and we get the same kind of carriers for all substances.

I would especially call attention to the simplicity of the effects produced at these low pressures : only two patches of

phosphorescence are visible. This is, I think, an important matter in connexion with the interpretation of these results; for at these low pressures we have to deal not only with the gas with which the tube was originally filled, but also with the gas which is given off by the electrodes and the walls of the tube during the discharge; and it might be urged that at these low pressures the tube contained nothing but hydrogen given out by the electrodes. I do not think this explanation is feasible, for the following reasons:—

(1) The gas developed during the discharge is not wholly hydrogen: if the discharge is kept passing long enough to develop so much gas that the discharge through the gas is sufficiently luminous to be observed by a spectroscope, the spectrum always showed, in addition to the hydrogen lines, the nitrogen bands; indeed, the latter were generally the most conspicuous part of the spectrum. If the phosphorescent screen on which the positive rays impinge is observed during the time this gas is being given off, the changes which take place in the appearance of the screen are as follows:—If, to begin with, the pressure is so slow that the phosphorescent patches are reduced to two bright spots, then, as the pressure begins to go up owing to the evolution of the gas, the deflexion of the spots increases. This is owing to the reduction in the velocity of the rays consequent upon the reduction of the potential difference between the terminals of the tube, as at this stage an increase in the pressure facilitates the passage of the discharge. In addition to the increase in the displacement, there is an increase in the area of the spots giving a greater range of values of e/m ; this is owing to the increase in the number of collisions made by the particles in the rays on their way to the screen. As more and more gas is evolved, the patches get larger and finally overlap; the existence of the second patch being indicated by a diminution in the brightness of the phosphorescence at places outside its boundary. As the pressure increases the luminosity gets more and more continuous, and we finally get to the continuous band as shown in fig. 6. At this stage it is probable that there may be enough luminosity to give a spectrum showing the nitrogen lines, indicating that a considerable part of the gas in the tube is air. It is especially to be noted that during this process, when gas was coming into the tube, there has been no development of patches in the phosphorescence indicating the presence of new rays; on the contrary, one type of carrier—that corresponding to $e/m = 5 \times 10^8$ —has disappeared. The presence of the nitrogen bands in the spectrum shows that nitrogen is carrying part of the discharge, and yet there are no rays characteristic of

nitrogen to be observed on the screen ; a proof, it seems to me, that different gases may be made by strong electric fields to give off the same kind of carriers of positive electricity.

Another result which shows that the positive rays are the same even although the gases are different is the following. The tube was pumped until the pressure was much too low for the discharge to pass, then small quantities of the following gases were put into the tube : air, carbonic oxide, hydrogen, helium, neon (for which I am indebted to the kindness of Sir James Dewar); the quantity admitted was adjusted so that it was sufficient to cause the discharge to pass and yet did not raise the pressure beyond the point where the phosphorescence is discontinuous. In every case there were patches corresponding to $e/m = 10^4$, $e/m = 5 \times 10^3$, and except with helium these were the only patches ; in helium, in addition to the two already mentioned, there was a third patch for which $e/m = 2.5 \times 10^3$.

I also tried another method of ensuring that at these low pressures there were other gases besides hydrogen in the tube. I filled the tube with helium, and after exhausting to a fairly low pressure by means of the mercury pump, I performed the last stages of the exhaustion by means of charcoal cooled with liquid air. This charcoal absorbs very little helium in comparison with other gases ; so that it is certain that there was helium in the tube. The appearance of the phosphorescent screen of tubes exhausted in this way did not differ from those exhausted solely by the pump.

The most obvious explanation of these effects seems to me to be that under very intense electric fields different substances give out particles charged with positive electricity, and that these particles are independent of the nature of the gas from which they originate. These particles are, as far as we know at present, of two kinds : for one kind e/m has the value of 10^4 , that of an atom of hydrogen ; for the other kind e/m has half this value, *i. e.* it has the same value as for the α particles from radioactive substances.

This agreement in the maximum value of e/m at different pressures is a proof that this is a true maximum, and that there are not other more deflected rays not strong enough to produce visible phosphorescence ; for if this were the case—*i. e.*, if the value of e/m for a particle that had never lost its charge temporarily by collision were greater than 10^4 —we should expect to get larger values for e/m at low pressures than at high.

I have much pleasure in thanking my assistant Mr. E. Everett for the assistance he has given me in these experiments.