

PART I. — LABORATORY METHODS OF LIQUEFACTION.

On the lowest temperature yet obtained

BY

Prof. Dr. H. KAMERLINGH ONNES.

Mr. President and Members of the Faraday Society and the British Cold Storage and Ice Association. It is with deep sorrow that I bring to remembrance here the great loss science has suffered by the death of my dear friend and colleague Prof. KUENEN, a not less heavy personal loss for myself. On account of his many-sided work in experimental and theoretical thermodynamics, Prof. KUENEN was highly interested in the present meeting. His most beautiful work, such as the discovery of retrograde condensation, lies in the domain of the equilibrium of the liquid and gaseous phases in which mixtures of gases separate. The part he would have taken in the discussion on industrial processes dealing with such mixtures would surely have been an important one. In the meantime he looked forward with great sympathy to my having the honour to address you. If it should prove that I could not read my paper personally he promised to do so. The day before his unexpected death I saw him bright and in full vigour and it is a deep sorrow now to remember that the happy conversation we had the last hour we spent together had its starting point in arrangements for the present discussion.

§ 1. **Introduction.** — When we approach the discussion of generation and utilisation of cold from the point of view of the application of liquefied gases in scientific laboratories and leave aside the study of the properties of matter at low temperatures, including the principles of thermometry in this domain, there are two points which come to the front. The first is to construct appliances which allow the making of measurements over all

the range of temperatures that have become accessible. The second to descend to a lower temperature than hitherto has been done.

As to the first point the paper of Dr. CROMMELIN gives a full description of the equipment of the Leiden cryogenic laboratory. The paper is in your hands, so I have not to dwell on the details of this equipment. But I hope to be allowed to emphasize that the true characteristic of the Leiden laboratory is to be found in its having a staff and a body of helpers as could only be formed in the long run of time. By constant contact with precision research in different departments of experimental physics, as well as with the historical development of the means to carry over these researches to always lower ranges of temperature, this staff has become the possessor of traditions which allow of the application of all experience gained in mastering the successive cryogenic difficulties to the attack of new problems of most varied kinds. In this way the laboratory with its staff realises in fact what has become more and more an international desideratum of science. Science asks now in many departments for specialisation. An investigator working in a special line and desiring to do any of his experiments at low temperatures, say at those obtainable with liquid hydrogen, will evidently find great gain if in arranging his special apparatus for work at these temperatures he can dispose of the help of a well trained staff to make this arrangement as efficient as possible. And when he has to perform with this apparatus experiments which offer many difficulties in themselves, the help of this staff will allow him to concentrate all his attention on the experiments, the manipulation with hydrogen going on so to say as if with water.

The number of problems to be treated in this manner is increasing every day.

As I decided some 40 years ago to undertake work at low temperatures, of course I had the conviction that it would give results of value for our understanding of the properties of matter. But the extension and importance which the work in this direction has attained, has widely surpassed any anticipation of mine. During the time that moderate quantities of liquid

air had become available for the experiments which first occupied my mind, the necessity of some time making measurements with liquid hydrogen made itself felt. Before hydrogen was liquefied, helium was discovered, which substance afterwards proved to extend enormously the domain opened by hydrogen. And again, before helium was liquefied the discovery of PLANCK's quantum lent a totally new aspect to low temperature work. After the liquefaction of helium superconductivity added an entirely unexpected field of research. So there is an ever increasing number of problems requiring work such as can be done in the Leiden laboratory. While on the one hand I shall shortly have the great satisfaction to be able to welcome the liquefying of helium in newly started cryogenic laboratories, on the other hand the international interest of the Leiden laboratory continuing its historical line of research becomes the more prominent.

There is one problem in this line which, as I said before, comes naturally to the front in the discussion of to-day. It is the extension to lower temperatures of the range in which researches can be carried out. And so I beg to be allowed to give a preliminary account of experiments leading to the realisation of the lowest temperature yet attained.

§ 2. **First experiments.** — As soon as the efforts to liquefy helium had succeeded, it was of course investigated whether it could be solidified also. This was even tried on the same day on which helium had for the first time been seen as a liquid. The method used was that of evaporation under reduced pressure. Fig. 1 shows diagrammatically the apparatus in which for the first time liquid helium has been seen and the circulation apparatus that served to obtain it. After having been preliminarily cooled in an appropriate way the compressed helium passes through the spiral in the refrigerator in which it is cooled down to the temperature of the hydrogen evaporating at the air pump. Having been reduced to this extremely low temperature it enters the regenerator-spiral, the end of which provided with a nozzle. Here it expands: part of it liquefies the LINDE-process and the vapour returns between the

coils of the regenerator-spiral, the escaping helium vapour being received in a gasholder and being compressed again by the pumps. The liquid helium collects at the bottom of the vacuum-glass of the liquefier, where its accumulation can be seen: the bottom part of the liquefier glass was unsilvered; the surrounding vacuum glasses, the first one containing liquid hydrogen, the second one liquid air, were also transparent. The glass with liquid air was protected against condensation of moisture from the air by a glass in which alcohol, kept at atmospheric

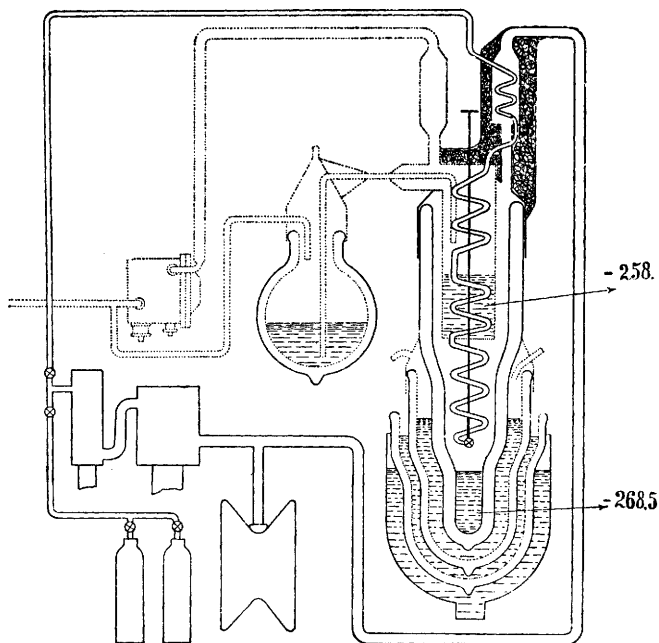

Fig. 1.

temperature, circulated. At the beginning of the experiment that was intended to produce refrigeration by evaporation of the liquid itself, the nozzle was closed and the pumps were put out of action. The vapour emanating from the helium at the bottom part of the glass of the liquefier passed under atmospheric pressure to the gasholder. The helium was seen boiling quietly.

In order to follow the evaporation of helium at reduced

pressure, it was only necessary to close the connection to the gasholder and to put into action the compressors now acting as vacuum pumps. The capacity of the pumps appeared to be great enough to remove the vapour so quickly that the temperature decreased considerably and, when their action was supported by a powerful vacuum pump, it was found that the pressure could decrease even to one centimetre, the helium still not ceasing to be a liquid.

At that time it was not possible to go further, as only an extemporized connection to the said powerful vacuum pump could be established. In 1909 the experiment was repeated after proper preparation to this end; the pump mentioned, a BURKHARDT pump with a capacity of 360 M³. per hour, could develop its full power. Then it appeared that, even when the pressure decreased to two mms., the helium did not become solid. Though, at this low temperature, the liquid lost its peculiarity of having its surface standing sharply defined, like the edge of a knife, against the wall and now showed the ordinary properties of capillarity, yet its striking mobility remained.

With regard to the obtaining of solid helium, this result was disappointing. However, it appeared from this result that the region of temperatures in which the properties of substances could be investigated by means of baths of liquid helium extended farther than might have been hoped for by analogy with the other gases of low critical temperature, and so far the result was gratifying. For it is very difficult to obtain by means of some definite substance constant and homogeneous temperatures below the melting point of that substance. With helium the difficulties would be so great that the temperature of solidification might be considered a limit, below which it could not be usefully employed. Therefore in absence of a more volatile substance a limit would here have been put to science. Each time, when with further lowering of the vapour pressure it is found that the helium remains liquid, this failure with regard to the solidification of helium means a gain: a new region of temperature, which on account of its extreme situation is especially important, has proved to be accessible to us.

§ 3. **Improvements in the helium-cryostat and cycle**¹⁾. — Happily it has been possible to obtain a considerably lower temperature than has been mentioned above and we have arrived near the point, at which the low density of the vapours brings in a new limit, below which we cannot descend. To day I will deal with the experiments by which this lowering of the known limit of the liquid condition of helium has been obtained. This advance, however, has gone on gradually hand in hand with the regular developments of the laboratory and the last steps have only been possible after considerable improvement in various directions of the appliances for research in the region of helium temperatures. An important improvement was obtained when we succeeded in transferring the liquid helium from the apparatus in which it had been liquefied to a cryostat, in which like other liquefied gases it can serve as a bath for definite temperatures in the ordinary way. The cryostat *C* is still closely connected to the liquefier *L* (comp. fig. 2) but the room in the cryostat that is available for experiments is now no longer blocked at the top by the regenerator-spiral as in the first apparatus. The necessary appliances can be brought freely from the top *o* into the cryostat (comp. fig. 4*b*), whilst the bath surrounding the apparatus may be obtained by syphoning the helium from the liquefier into the cryostat. Such cryostats have been used already in several researches on the properties of substances at very low temperatures, especially in the domain of electricity and magnetism. Fig. 3²⁾ shows the apparatus together with a diagram of the improved helium circulation, in which such a cryostat has been inserted. The helium, that liquefies on leaving the nozzle *k* of the regenerator-spiral, collects in the bottom part of the liquefier vacuum glass as in the first liquefaction experiments. This glass, however, is not closed at the bottom but ends in a double walled silvered syphon tube *s* (fig. 2), provided with a valve *v*.

¹⁾ I gratefully acknowledge here a considerable augmentation of the stock of helium by the splendid gifts of the American Navy, 30 M³, and of Prof. Mc LENNAN, 6 M³.

²⁾ Partly schematical, partly with the single objects to scale.

When this valve is kept tight, a supply of liquid helium can be collected in the liquefier glass. By opening the valve (comp. v_0 , fig. 2 and fig. 5) liquid helium can pass to the actual cryostat. This cryostat itself consists of an unsilvered vacuum glass, in which the liquid helium is collected. This glass is surrounded by a second

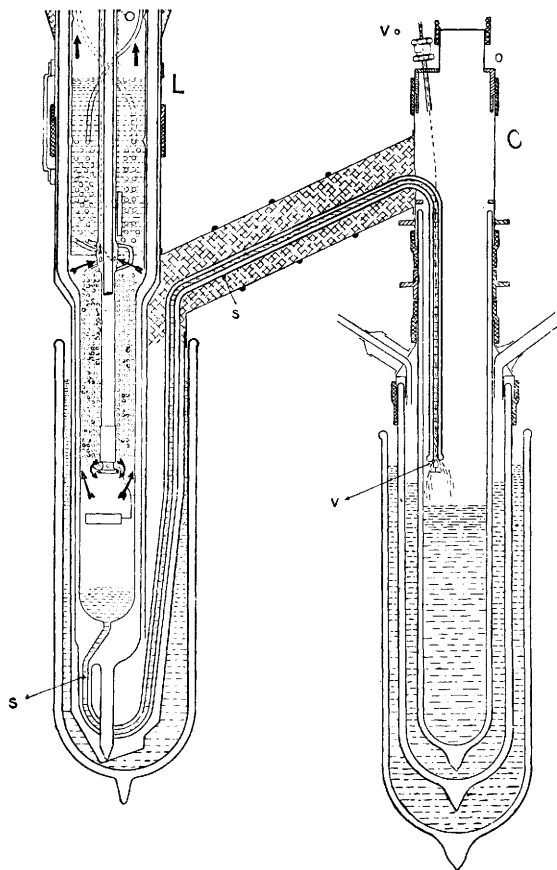

Fig. 2.

vacuum glass. In silvering it two vertical slits (comp. fig. 5, p) at opposite sides were left clear to render visible what happens in the helium glass. The second vacuum glass is surrounded by a third one, silvered in the same way and containing liquid air. The vapours arising from the cryostat and

those coming from the liquefier are received in the pumps P_1 , P (fig. 3) used for the following purpose; when the circulation is in action these vapours are driven back by the pumps to the liquefier, there to renew the supply of liquid helium. With the arrangement set up the process of liquefying helium may be continued, whilst the actual experiments are performed with

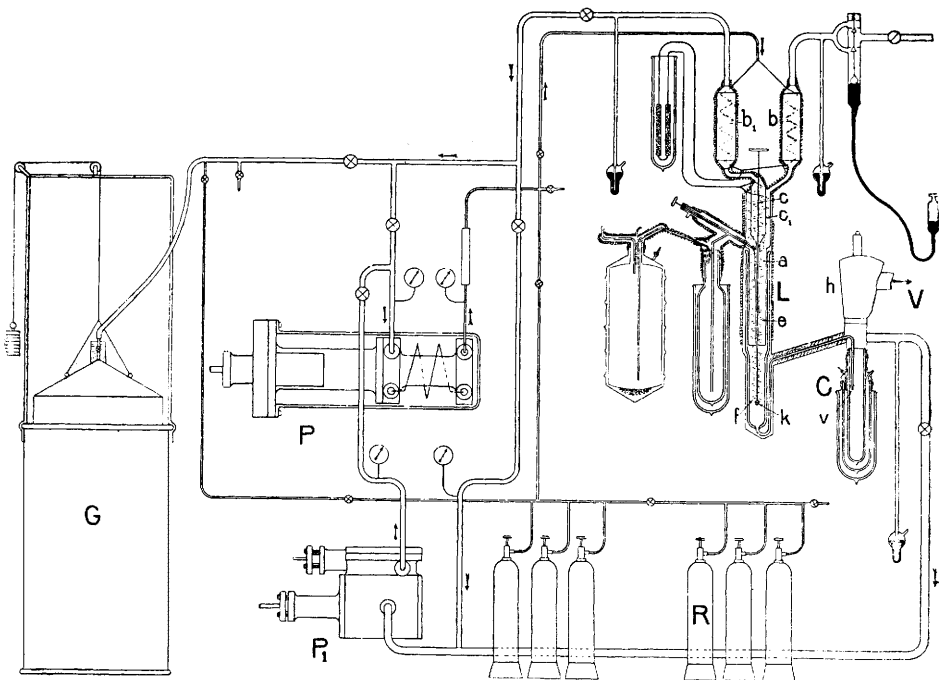

Fig. 3.

the aid of the helium bath in the cryostat. As soon as too much helium has evaporated from the cryostat, the supply in the liquefier may be used to provide again the desired quantity.

The improvement in dealing with liquid helium, obtained by the separation of cryostat and liquefier, was accompanied by an improvement of the liquefier itself that led to a more rapid preparation of liquid helium and at the same time a more economical use of liquid hydrogen. The main part of the modification consists of a more efficient use of the available cold.

The helium, after being compressed to 30 atmospheres is divided (fig. 3) between two spirals b and b_1 that unite again, bring the helium through a tube containing charcoal cooled in liquid air and are again divided into c and c_1 . b and c are cooled by cold hydrogen vapour arising from the liquid hydrogen in the refrigerator, b' and c' by cold helium vapour arising from the liquefier glass. Both spirals are much longer than in the first liquefier; they unite to form the spiral a and pass, just as with the first liquefier, after cooling by hydrogen vapour surrounding a and by liquid hydrogen surrounding e , into the regenerator-spiral f , which is provided with a nozzle k ¹⁾.

Besides obtaining in this way by better regeneration larger efficiency of the liquefactor, the capacity of the circulation has been increased by insertion of larger compressors P , P_1 , which at the same time can act as vacuum pumps.

So in the new cryostats one had for hours at one's disposal a bath of say 500 cm³. of liquid helium evaporating at a pressure of 3 mms. It was possible to perform extended experiments at temperatures whose attainment could hardly have been demonstrated in the early experiments with liquid helium. Such a cryostat with a bath of already extremely low temperature has been used with much advantage in the experiments on cooling helium still further by its own evaporation. The vaporisation apparatus (fig. 4), in which helium has been reduced to the lowest temperature that has been attained, consists mainly of a small double-walled vacuum flask a (fig. 4a), containing the helium when it is cooled as much as possible, and of a wide outlet tube b for the gas formed by the vaporisation. The vaporisation flask is immersed (fig. 4b) in the intensely cooled helium bath of the cryostat C ; the gas escaping from the outlet b leaves the cryostat through the lid h which is connected to powerful vacuum pumps V (fig. 5). It is evident, that those pumps not only must cause a high vacuum, but at the same time must have an extremely high capacity at the pressure of this vacuum, since the gas formed by the vaporisation will occupy a large volume at atmospheric temperature and at the low vaporisation pressure.

¹⁾ For further particulars see Leiden Comm. N^o. 158 and Suppl. N^o. 45.

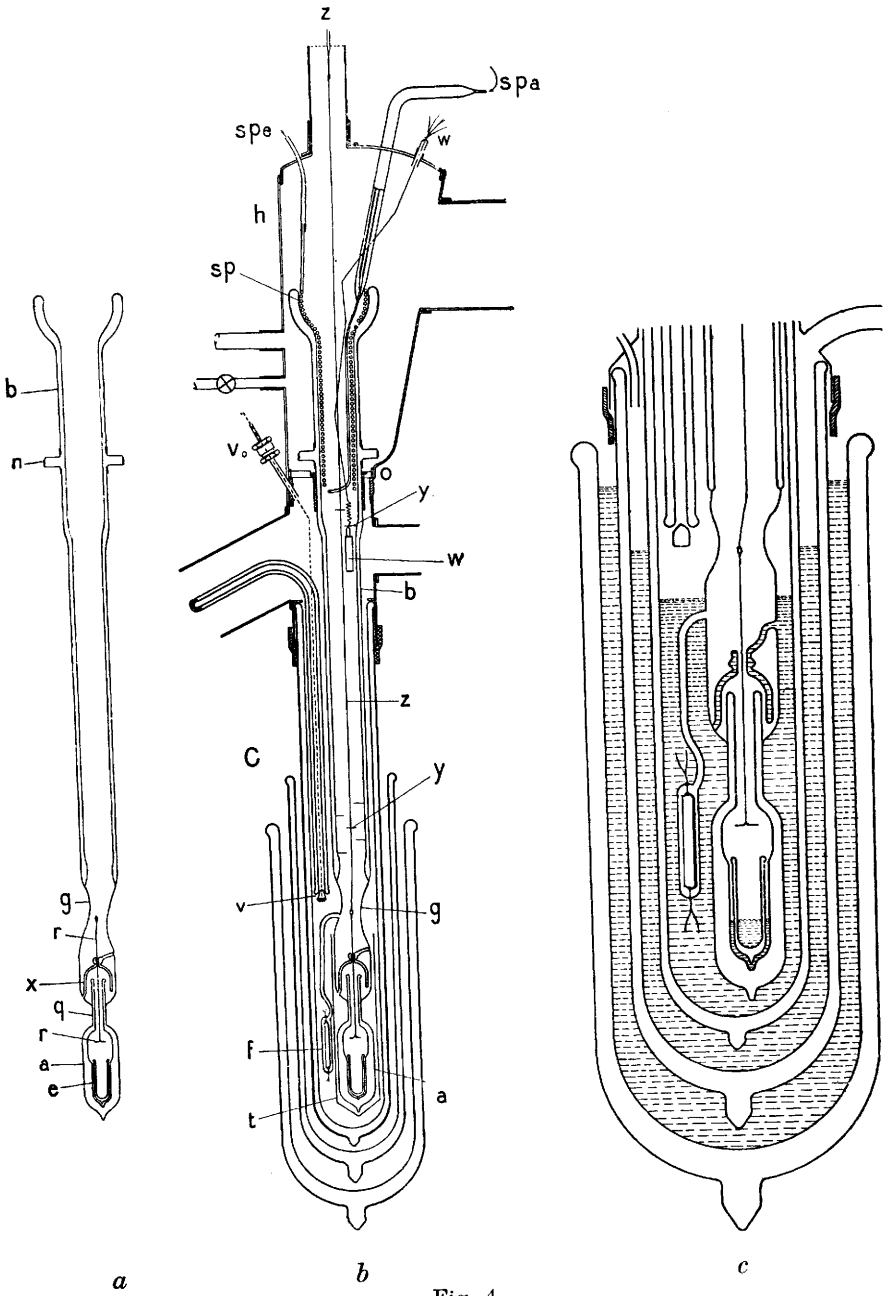

Fig. 4.

Similarly it is seen at once, that the aim can be attained only if the cryostat affords opportunity to these large volumes of gas to escape by a wide outlet, as indeed it did in the apparatus used. If the tubes in which the gas moves are not very wide or are not at very low temperatures, the movement of the gas at the low pressures under consideration requires differences of pressure of the same order as that at which the gas is pumped away. These differences of pressure might form a considerable part of the pressure at which the helium evaporates.

§ 4. **Temporary set-back.** — These two considerations show already that great demands must be made on the appliances to be used for the experiments and especially on the capacity of the vacuum pumps, if descent to a very low pressure is aimed at. Now in 1910 an experiment had been performed in this direction on the same principle as has been followed now, but with insufficient appliances. Notwithstanding that the cryostat was deficiently conceived, by a fortunate accident a lower limit for the vapour pressure was reached than that obtained in 1909. Though this result could not be obtained again on repetition of the experiment with apparatus arranged in the same way as when the experiment succeeded, yet there was left no doubt that the vapour pressure could descend far below 2,2 mms. without solidification of the helium and that even at a vapour pressure of 0,2 mm. it would probably not solidify. This meant, however, that in order to ensure a quite certain progress, much higher demands had to be made on the experiments than when one stood only at 2,2 mms. as the lowest limit. Thus many years elapsed before one could think of lowering the limit below that accidentally found as 0,2 mm. and this problem had to be set aside and the treatment of various problems, more important for the moment and more in accordance with the gradual development of the appliances was first proceeded with; e. g. those concerning the superconductivity and the threshold value of the magnetic field by which ordinary resistance is generated in superconductors. The lowest temperature obtained remained that which corresponds to 0,2 mm. vapour-pressure. I had estimated this

temperature at $1^{\circ},15$ K. Taking into account the uncertainty of this estimation it would have been better to have said that *in descending one had approached to nearly 1° K.* As the state of the helium work progressed it became more and more necessary that a limit for the vapour-pressure more in accordance with its new feature than 0,2 mm. had to be given and especially it had to be established whether it would be possible to penetrate below 1° K. At last however in 1919, this problem could be attacked, when the difficulties of the years of war and of crisis had been overcome.

§ 5. **New attack.** — For the removal of the helium from the evaporation apparatus a large BURCKHARDT vacuum pump V_{B_1} of 360 M³. per hour capacity could then be used, coupled in series with one of 18 M³. capacity V_{B_2} , and a SIEMENS pump V_3 of 2 M³. capacity. The arrangement and treatment of the large high-vacuum pump V_{B_1} were such, that there was no possibility of gas being given off from the lubricating oil into the vacuum. At the beginning the valves, which previously had been kept shut by means of *springs* until the gas by its own overpressure flowed from the pressure side of the cylinder into the outlet, were *now* opened and shut by a *mechanical arrangement* at the correct moment for the equalising of the pressure in both spaces. Later on the valves on the pressure side were taken away and the latter connected simply to the suction side of the auxiliary pump. With this pumping arrangement which had a limiting suction pressure of 0,04 mm. (in the best case 0,025 mm.) and with an evaporation glass which, though not so good as but in the main set up like that which served for the experiments which I shall describe, a volume of 2,7 litres of gas per hour (measured at N. T. P.) could be removed and the pressure of suction at the *top* of the cryostat reduced to 0,1 mm. It was concluded that the *vaporisation pressure* was again smaller than had been obtained in 1910, perhaps it may be estimated to have been reduced to 0,15 mm. When the pressure had fallen to this value, there occurred no further change in the evaporation, equilibrium between the heat received and the cooling by evaporation being attained.

The helium again did not solidify and the limit for the pressure had again been somewhat lowered, which again led to higher demands on later experiments.

§ 6. **Battery of condensation vacuum pumps.** -- Real progress could be made only by executing a long cherished

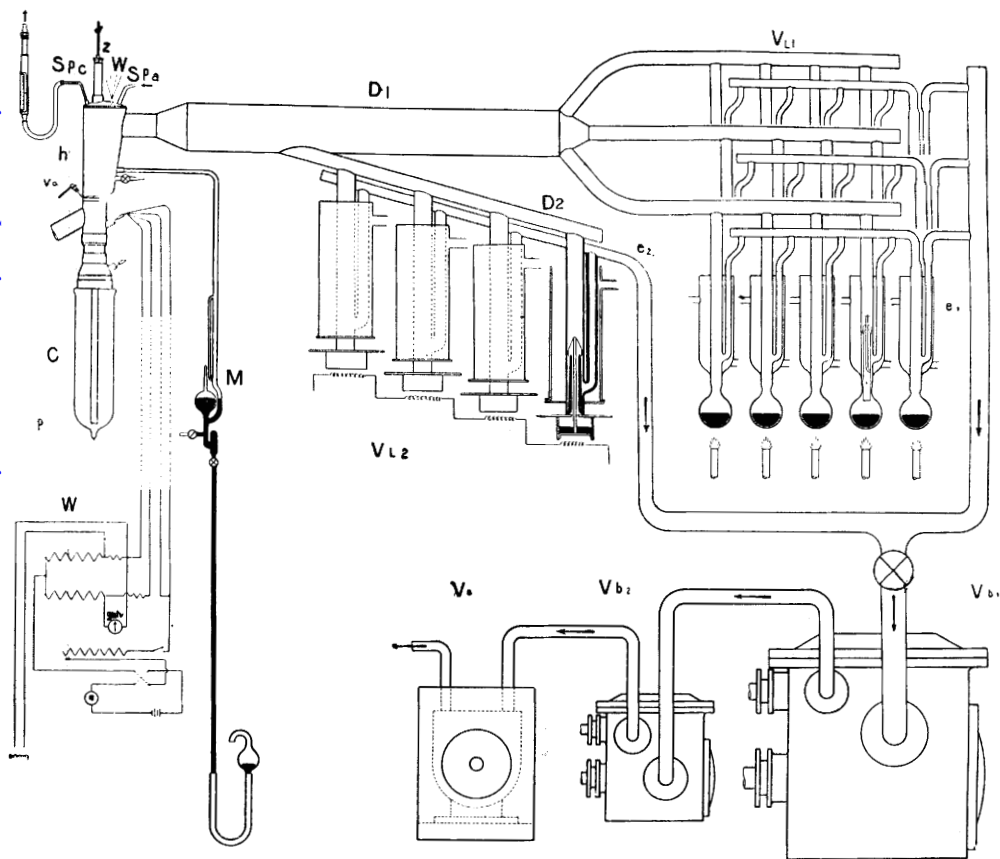

Fig. 5.

plan, namely: the construction of a vacuum pump-complex of very large capacity with extremely low suction pressure. This was intended to consist of a large number of LANGMUIR condensation pumps connected in parallel. In 1920 the first step was made in the realisation of this plan and since then the battery

of pumps has been regularly enlarged¹⁾. In the experiments now described the battery had already grown (fig. 5) into

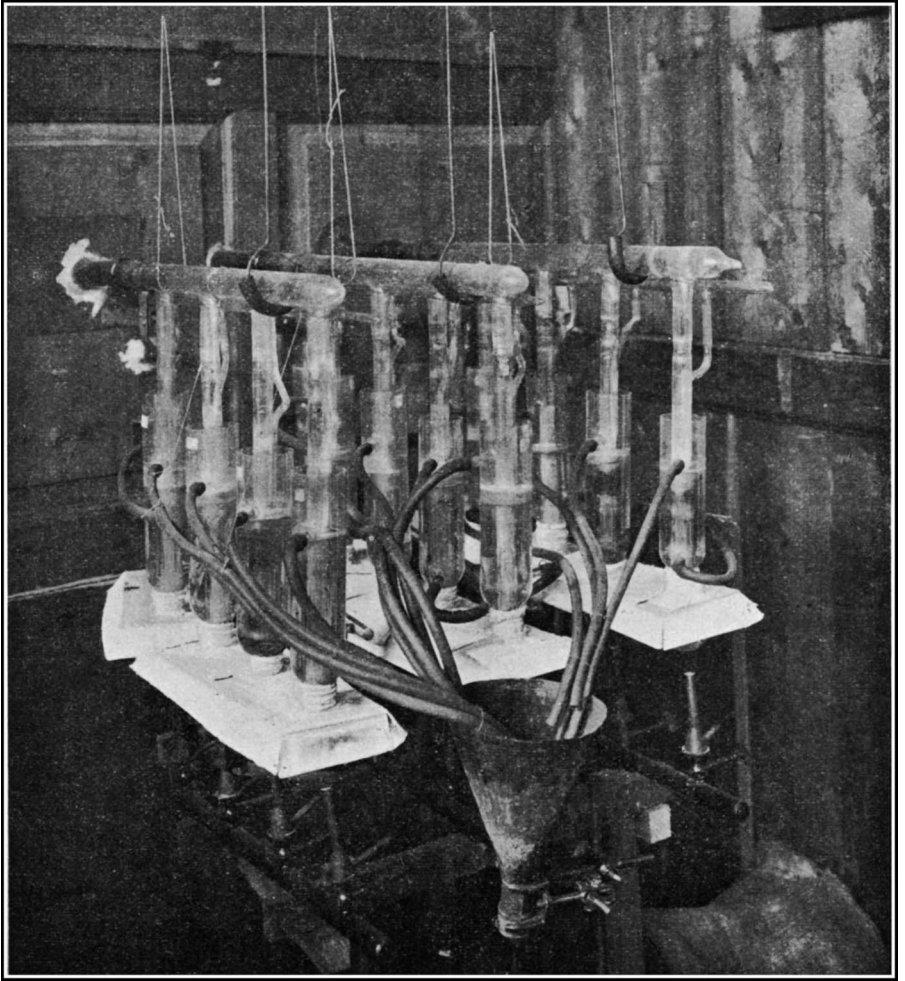

Fig. 6.

one of 12 glass (V_1) and 6 iron (V_2) LANGMUIR pumps, connected

¹⁾ My best thanks are due to PHILIPS' Incandescent Lamp Works, Eindhoven, for presenting us, at the beginning of our attempts, with a number of these pumps.

in parallel into one single complex. The BURCKHARDT pumps connected as before in series served as the auxiliary pump. This is shown diagrammatically in fig. 5¹⁾.

The battery of twelve glass pumps (see fig. 6) consists of three series of four pumps, each series having (as later appeared superfluous) a LANGMUIR pump as auxiliary (fig. 5) before being connected to the actual auxiliary consisting of the complex of BURCKHARDT pumps. In this battery the mercury of the condensation pumps is heated by means of gas. Since flames are not permissible in such a room as the department for helium experiments, the battery is built into a small separate room in the department. The room containing the battery is ventilated with outside air by means of a fan, which maintains a blast of air through the nicks in the walls into the helium department²⁾.

All connections to be found on the glass pumps were made by sealing together. The different series were cemented to the copper suction-tubes which united in a main D_1 of twelve cms diameter. As far as the copper tubes were not soldered to each other, they were cemented together just as the main is to the cap of the evaporation apparatus. The only connection by rubber was that of the tubes coming from the auxiliary LANGMUIR pumps to the suction tube of the Bureckhardt V_{b1} . Further, all the copper used is varnished.

In general the iron pumps are not so suitable for the highest vacuum as the glass ones, but they are quite good enough to procure the high vacua with which we are concerned here. They are heated electrically and attention must be paid continually in order that one of the cemented connections does not give way. But I will not further dwell on these details, nor on the adversities and disappointments which necessarily accompanied the experiments which I am describing now, before they were concluded satisfactorily³⁾.

¹⁾ Partly schematical, partly with the single objects to scale. One should take into account the historical development.

²⁾ In case of emergency all flames can be put out at once.

³⁾ We must point out that, if one of the pumps suddenly burst, a large quantity of air would have to be received by the BURCKHARDT-pump. Besides

By the aid of the battery with which I am dealing now, on a suction-pressure of 0,005 mm. at the evaporation apparatus, a capacity of one litre (at N. T. P.) of removed gas per hour was finally obtained, corresponding with an evaporated quantity of 1,25 cm³. per hour of liquid helium at 2° K.

§ 7. **Minimising the heat conveyed to the evaporating helium.**

— The very large capacity of the pumping arrangement may be utilised the better, the more the helium which has to be vapourised is protected against conveyance of heat and the more the frictional resistances between the evaporating helium surface and the pumps are diminished. Both requirements are, however, very difficult to combine in the construction of the evaporation apparatus: a wider outlet tube will diminish the frictional resistance, but at the same time it will give rise to a larger heat conveyance through the glass walls and especially by conduction in the column of gaseous helium in the tube. Both requirements have been satisfied as much as possible in the construction of the evaporation apparatus shown in fig. 4, which was used in the last experiments in 1920 and 1921. (For the meaning of some details of the construction see also §§ 9 and 10). Besides the small evaporation flask *a* with double-walled evacuated interspace and the similarly double-walled outlet tube *b*, the interspace of which can be evacuated through a tap ¹⁾, we notice a single-walled part *g*. Advantage is taken of the latter to introduce, by means of an artifice, liquid helium into the evaporation-flask. To bring this about, helium is introduced into the helium space connected with the high-vacuum pumps, i. e. the evaporation apparatus, the connecting tube to the pumps and the pumps themselves, the battery of condensation pumps and the auxiliary pumps being out of action. The pressure is thus allowed to rise above the vapour pressure occurring in the bath of the cryostat. Inside, the liquid helium then flows down along the walls and so fills the bottom part of the apparatus. By again putting into

safeties to the Burckhardt itself a shutting-slide has been placed in the suction-tube. This slide could be shut on the first signal.

1) Any small lowerings of the vacuum consequent on the presence of soldered metal can be remedied by these means whenever necessary.

action the auxiliary pumps evaporation under decreasing pressure is brought about until only the required quantity of liquid helium is present in the evaporation glass, in which, protected against heat absorption, it cools further until, to go lower, the high-vacuum pumps have to be put into action and the actual experiment can be commenced. The pressure under which suction occurs at the cap of the evaporation apparatus is measured with a McLeod manometer *M*, fig. 5. Special care has been taken to prevent heat penetrating by conduction or by radiation into the helium in the evaporation flask. It is necessary to pay attention also to the radiation given out by parts of the apparatus remaining at ordinary temperatures, e. g. that coming from the cap above the outlet tube through which the evaporised helium is led away. The order of magnitude of this radiation may be estimated by comparison with the total black radiation from a plane surface ($4.8 \cdot 10^{-9} \cdot T^4$ gram-calories per hour and per cm^2). Substituting the value of the ordinary temperature in this expression one arrives at 30 gr. cal., which, on account of the small heat of vaporisation of helium, about 6 cal., suffices to vaporise a quantity of liquid which occupies some 30 litres at N. T. P. when in the gaseous state. The pump-complex is, however, calculated to remove at the pressures under consideration only a quantity of gas corresponding to one litre at N. T. P. per hour. The radiation towards the evaporation flask should be received as much as possible by opaque metallic screens which are cooled down to low temperatures, preferably to the temperature of the helium bath in the cryostat. The radiation from screens cooled to this degree, on account of its dependency on the fourth power of the temperature, is so small as to be negligible. Protection against the radiation falling sideways on the walls of the evaporation flask may be especially easily realised: the entire lower part of the evaporation glass is surrounded by a metal bowl, the upper side of which extends beyond the surface of the liquid helium in the cryostat. In this bowl two slits are left open in order to render the evaporation flask visible through the unsilvered strips of the vacuum glasses. As a rule the slits are kept shut by means of two screens, which may be rotated around the bowl. They are removed only when the level of the liquid must be observed;

for illumination, use is made of a metal filament lamp, placed behind an alum solution. In order to shut off heat conveyance from above by radiation into the evaporation glass an arrangement has been constructed, by which the whole — made by Mr. KESSELRING, chief of the glassblower department — became a masterpiece of the glassblower's art. Above the evaporation flask *a* there is sealed into the glass a double-walled cap *x*, the interspace of which is connected to the outside of the vacuum tube. The helium in the cryostat flows through the annular space of the cap, the upper side of which is blackened and the lower silvered. Radiation from above can only penetrate by reflection along the walls of this cap. The heat transference from above has been further minimised by narrowing down the single-walled middle part as much as the strength of the apparatus and the quantity of escaping vapour would allow. Further, screens *y* cooled by the ascending gas and by other means to which we will refer later, were so placed in the outlet, that they did not hinder the free escape of the vapour. The inner walls of the outlet were blackened with a mixture of soot and celluloid solution in order to diminish the reflecting power. Finally, there serves to the same end the spiral *Sp* that has been introduced at the top, through which liquid hydrogen is forced and which removes part of the heat which otherwise would have been conducted below by the walls. In another respect also advantage has been taken of the glassblower's art in the construction of this evaporation glass. As we have seen, the outlet tube has also a double-walled upper part, silvered and evacuated between the double walls. The stresses which originate on account of the great difference of temperature between the inner and outer walls, are taken by a metal case *n* soldered to the glass and serving as a spring. The heat transferred from above to the lower parts through the walls across the narrowing is taken up by the bath of the cryostat¹), the level of the liquid in the cryostat being always kept above the narrow portion *g*. In this

¹) The heat thus deviated to the bath has no perceptible influence on the rate of evaporation and hence on the time during which the experiment can be continued.

way it is tried to ensure that the temperature of the helium gas above the evaporation flask is not appreciably higher than that of the bath.

The neck of the evaporation flask in which the evaporation under very low pressure occurs was long and narrow, firstly to reduce the heat conduction through the glass as much as possible, the small radius allowing the inner wall to be made very thin and secondly to make the velocity, with which the vapour escapes, great enough to carry away the heat which otherwise would enter by conduction along the column of helium gas. In all this attention has been paid to the limit at which disadvantageous frictional resistances would make their appearance.

All the above mentioned precautions having been taken to protect the helium in the evaporation flask as much as possible against heat transference, the vaporisation appeared to have been reduced to 0,9 litres of normally measured gas. The suction-pressure produced by the high-vacuum pumps at the cap of the evaporation apparatus was shown to be 0,0055 mm. by the McLeod-gauge.

In the hope of reducing the quantity of glass which finally had to be cooled down by the evaporating helium, an especially thin-walled small vacuum glass *e* was placed at the bottom of the evaporation flask. It was thought that on continued pumping the liquid in the small glass would continue to evaporate after the liquid surrounding the glass had evaporated, so that the circumstances for cooling the helium would become more favourable, as less glass had to be cooled and less heat would be conveyed along the wall. It will be seen presently that peculiarities in the course of the evaporation brought it about that the liquid level inside and outside the small glass sank at the same rate. As regards further progress in reaching lower temperatures, the bowl did not fulfil expectations.

§ 8. **Minimising the frictional resistance on the way from evaporating helium to pumps.** — I will now proceed to discuss the minimising of the frictional resistance of the vaporised helium in the evaporation apparatus on its way from the liquid surface

to the high-vacuum pumps and hence using the low-suction pressure of the pumps to the best advantage at the evaporating surface. The width of the outlet tube could be increased only as far as the size of the top of the cryostat *o* (comp. fig. 4*b*) allowed. The opening in the latter could not be widened without rebuilding the whole cryostat¹).

With the greatest width at present available for the outlet tube, the gas would, as a consequence of receiving heat in ascending, acquire so great a velocity, that a frictional resistance much too large for our experiments would occur, unless special means were taken to prevent this. For this purpose there has been placed in the top of the outlet tube a lining that can be cooled strongly by external means. This lining consists of the copper spiral *Sp* through which liquid hydrogen can be led. The spiral is connected to a Dewar flask of liquid hydrogen and the liquid is forced under a small overpressure through the former; the supply being regulated by a flow-meter showing the quantity of evaporised hydrogen. Not only does this lining, through being thus cooled, reduce considerably the heating of the vapour in its ascent through the outlet tube and contribute to the prevention of radiation by the cooling of the various screens, but it also takes up, as we have said, part of the heat penetrating from above along the glass walls of the evaporation glass. By means of a small resistance thermometer placed under the lowest turn of the coil it can be ascertained whether the arrangement is working properly; in the experiments that succeeded best the temperature underneath the spiral decreased to -200° C. Then the loss of pressure due to frictional resistance, as we shall see, is reduced to only 0,01 mm.

§ 9. **Determination of pressure.** — In determining the pressure in the space immediately above the level of the evaporating helium use was made of a resistance manometer. Pressures such as those which occur above the surface of the evaporating helium are too small to be measured by means of a suitable mercury

¹) The extensive work necessary for the construction of a further cryostat with a wider opening at the top is in hand.

manometer except with a very rigid arrangement such as would be very troublesome in this case. From this point of view a resistance manometer is already preferable. The manometer tube further may have very small dimensions and the manometer can be calibrated very well for pressures between 5 and 20 bars. Whatever manometer is used, if the space of the manometer is at ordinary temperatures and is connected to the space at the lower temperature by a narrow tube, the pressure in the manometer space will not be equal to that which has to be measured. At the low pressure at which the helium evaporates, the mean free path of the gas molecules, except where the connecting tube is at a very low temperature, is probably many times greater than the diameter of the tube. Between the space at low and that at ordinary temperatures there occurs a pressure difference equal to the thermal molecular pressure. The hope¹⁾ that this difficulty inherent in measuring pressures at low temperatures could be avoided by the use of the resistance manometer, as it was here possible to keep the manometer tube itself at a low temperature, has happily been confirmed by a series of experiments carried out in collaboration with Mr. VAN GULIK. So the pressure below in the evaporation flask has been determined by means of a resistance manometer, the manometer tube of which was kept at a temperature but little above that of the evaporating helium by being immersed in the helium bath outside the evaporation flask. In fig. 4*b* and *c* is shown how the manometer tube is sealed to the lower part of the evaporation glass; in fig. 5 the arrangements *W* for the measuring of the resistance are shown diagrammatically. At first sight it seems doubtful whether the principle on which the resistance manometer is based, viz. the change of resistance of the manometer wire with temperature, can be applied at a temperature so low that the resistance of the wire has not only fallen to a very small value but also does not change with temperature, as is the case with a platinum wire at the temperature of liquid helium. But it appears that the resistance remaining at this temperature, viz. the additive resistance, is still sufficient (if a still serviceable small current flows through the

¹⁾ Cf. Leiden Comm. Suppl. No. 34*a*.

wire) to heat the wire until the temperature is reached at which the resistance begins to increase distinctly and so the influence of the pressure on the loss of heat from the wire becomes observable through the difference of current necessary to maintain the same resistance. Though the measuring apparatus, if used in this way, becomes a means rather of indicating than of measuring the pressure, yet by calibration at known pressures the desired aim is attained. In this calibration the apparatus was filled with gaseous helium at rest and with its lower end immersed in the same way as in the experiments in the helium bath. The upper part protruding into the cap of the cryostat remained at ordinary temperatures. The tube *b* is not wide enough to render quite superfluous a correction for the thermal molecular pressure between the upper and lower parts. The accuracy of the values of the pressures, which will be given presently, will be increased therefore, when the uncertainty resulting from the fact that the correction has as yet only been *calculated*, will be removed by new *experiments*. I will not dwell, however, at present on this correction, which is only 0,003 mm. Also we neglect the difference which may still exist between the pressure in the manometer tube and that at the surface of the helium itself.

§ 10. **Stirring arrangement.** — Lastly we have to mention the small stirrer *r* introduced into the evaporation flask *a*. With the arrangement of the evaporation glass shown in fig. 4 it consisted of a horizontal glass disk attached to a vertical glass rod. It can be moved up and down by means of a wire *z*, attached to a rod, which passes a glass tube in the cap; the tube is closed by means of a packing gland¹⁾.

§ 11. **The final experiments.** — For the success of the experiment with the complicated arrangement which has been described

¹⁾ In an earlier experiment a spring was inserted between the wire and the rod. A diamond was suspended from the wire instead of the disk. If the helium had solidified and the diamond had encountered resistance, the spring would have been stretched in its movement up and down.

(and of which fig. 7 gives a view), it is necessary that numerous operations should be performed each in the time allotted to it and in regular order, the success of each of the operations themselves depending upon careful preparation.

A small amount of condensation on one of the glass walls through which the evaporation of the helium must be watched suffices to render observation impossible: on walls cooled in liquid hydrogen a gas rendered impure by traces of air gives condensation. On reflecting on what is required to keep the glass walls through which it is necessary to see, perfectly transparent for hours after liquid helium has been introduced for

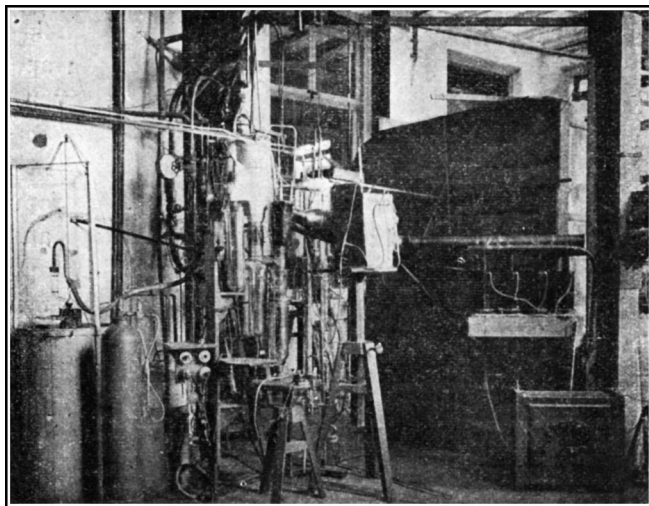

Fig. 7.

the first time into the cryostat, it will be understood that I am greatly indebted to Mr. FLIM, the chief of the technical department, for his devotion to the work. Thanks to him everything went according to plan.

Early in the morning the preparation of 24 litres of liquid hydrogen was commenced, the previous day having been spent, on the one hand, in evacuating the apparatus and further putting it in working order and, on the other hand, in preparing a sufficient quantity (more than 50 litres) of liquid air. Meanwhile the

following preparations were carried out: the helium circulation was further put in order; the pump, which had to remove the hydrogen from the helium liquefier at reduced pressure, was started; the space reserved for the liquid air used in cooling the hydrogen was next filled and the liquid hydrogen space filled, after having been first cooled with dry cold hydrogen gas. At 12 o'clock the liquid helium could be syphoned over into the cryostat, after which we proceeded to cool this bath further by evaporation and refilling by means of the helium circulation. At 1 o'clock the condensation of the helium into the evaporation apparatus could be commenced and the bottom part of the evaporation glass was filled up to somewhat above the double-walled cap mentioned earlier. At about 3 o'clock this helium had evaporated so far as to occupy only the lower part of the evaporation flask, the evaporation taking place first under the action of the auxiliary pump complex, later on under that of the combined high-vacuum and auxiliary pumps, which serve for the removal of the helium from the evaporation apparatus. The evaporation was further observed alternately with the naked eye and with the telescope of a cathetometer, the screens around the evaporation flask being kept shut as long as possible. Neither by means of the stirrer nor with the naked eye or with the telescope could anything be observed that pointed to the solidification of the helium even at the lowest vapour pressure observed; the liquid retained its great mobility throughout.

§ 12. **Evaporation at different levels.** — Further, it was observed that contrary to the expectation that the layer outside the small glass would evaporate first and then the helium inside the glass, both liquid levels fell at the same rate, so that they remained in the same horizontal plane. If (comp. fig. 8) by means of the lid shaped stirrer *r* (fig. 4*a*) liquid was thrown from the inside to the outside, the outside level fell rapidly while that of the liquid inside rose until they were again in the same plane. If, by removing the screens and allowing the radiation from a lamp to fall on the evaporation flask, the outer layer was caused to evaporate, after turning the screens the outer layer was re-formed at the expense of

the helium within the small glass, and increased until both levels were at the same height, after which both again fell at the same rate. The speed of readjustment by this distillation was striking. A correct judgement on this phenomenon will only become possible, when the determinations we have in view concerning the heat conductivity of glass, of helium vapour and of liquid helium have been carried out, whilst a knowledge of the latent heat of evaporation and of the specific heat of liquid helium and of glass and of the viscosity of gaseous helium is also desirable.

The property of a maximum density shown by helium has of course great influence on the observed evaporation. Observations in 1911 had brought this property to light, but it was not sufficiently established whether the density approached a limiting value or whether it decreased at still lower temperatures. That the latter is the case has been established by a repetition of the experiments undertaken in collaboration with Mr. Boks after the completion of the experiments with which we are dealing now. This confirmation holds only so far as the possibility of some peculiarity in the expansion of glass is excluded. On cooling the surface of helium below $2,2^{\circ}$ K., the coldest layers of the liquid remain at the top. While in other cases in working with baths at reduced pressure care has been taken to stir vigorously, in this case stirring has been omitted, as this would have made a claim on the already small amount of available space at the top of the cryostat. The presence of a stirrer in the outside bath would probably have made the heat transference to the evaporation flask still smaller than it actually was. It was hoped that the means which have been applied would have reduced the heat transference to one half of what it seemed to be assuming that there is no special change in the latent heat of vaporisation.

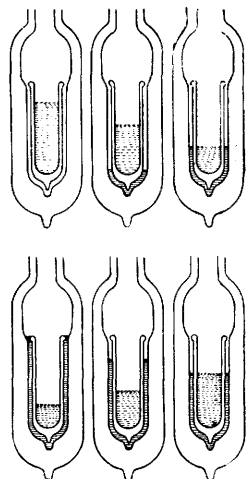

Fig. 8.

§ 13. **Lowest limit of evaporation pressure.** — However this may be, when the level of the evaporating helium had fallen to the bottom of the narrowest part of the evaporation flask and to about half the height in the small glass, it appeared that the lowest vapour pressure was reached that could be obtained with this apparatus. Neglecting the small corrections mentioned above, the pressure at the surface was 0,012 to 0,014 mm., mean 0,013 mm. In the cap there was a vacuum of in the mean 0,005 mm. The pressure difference due to the friction of the rapidly escaping vapours of low density was in the mean 0,008 mm. This value agrees sufficiently well with the result of a special determination of the frictional pressure experienced by helium moving through the apparatus with the same velocity. In this control experiment the evaporation flask was substituted by a tube through which helium, cooled to liquid hydrogen temperature and of the same density as in the actual experiment, flowed with the same velocity. This control experiment gave 0,009 mm. The observed frictional pressure also agreed with an estimate based on the probable distribution of temperature along the column of ascending helium. In round numbers and allowing for the existing uncertainties we may say that the limit for the evaporation pressure has been brought below $\frac{1}{50}$ mm. and that we have progressed ten times as far as in the experiments of 1910 on which was based the estimate of the temperature mentioned as the lowest one then reached. In temperature difference as measured by KELVIN degrees this means, as we will see in § 14, only a very small range.

Returning to the question of the solidification of helium we come to the following conclusion: as there is provisionally no doubt that helium has a maximum density (see § 12) and as it is even not solidified at a temperature below the half of that of the maximum density we cannot escape the question whether helium will not *remain perhaps liquid even if it is cooled to the absolute zero.*

§ 14. **Determinations of temperature.** — It still remains to consider the question of what temperature corresponds to the evaporation pressure found. For the latter pressure an experi-

mentally established value can as we have done be given, apart from a few probably small corrections which demand further study; the same cannot be said of the temperature. In the determination of the extremely low temperatures, at which even the

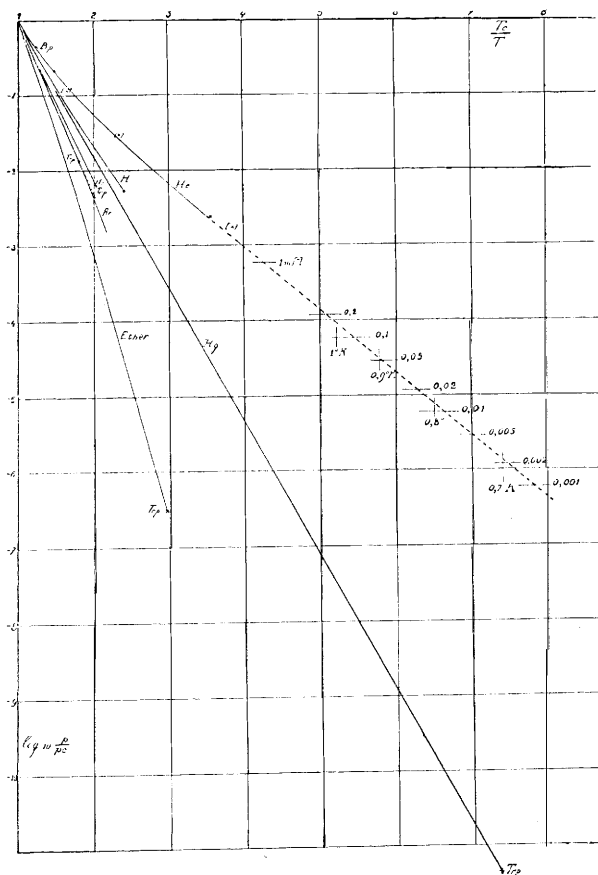

Fig. 9.

helium gas thermometer can no longer be usefully employed, we enter a region the study of which has only commenced. Therefore we fall back on the law of corresponding states of VAN DER WAALS to guide us now in extrapolating the law con-

neeting temperature and vapour pressure to lower temperatures than those for which it has been established experimentally. The latter has been done for the range in which it has been possible till now to use the helium gas thermometer. In this case the construction of the thermometer had to be adapted to the pressure, which introduced complications. In fact the pressure must be very low if the simple gas laws are to be applicable and even if only liquefaction is to be prevented. When the pressure becomes small, the correction for the thermal molecular pressure (the pressure difference between the thermometer reservoir at low and the manometer space at ordinary temperature) in this case also has to be applied. But notwithstanding these difficulties we succeeded in measuring vapour pressures of helium down to $1,5^{\circ}$ K., in 1911 and 1913 with a thermometer with a mercury micromanometer and in 1917 with two thermometers with hot wire manometers. The results are plotted in the accompanying fig. 9, in which the abscissae are the reciprocals of the reduced temperatures and the ordinates the logarithms of the reduced pressures. The point is how to extrapolate the line which passes through the observed points. For this purpose the vapour pressure curves of ether, mercury, argon, neon and hydrogen are shown on the same graph ending in the triple-point of each substance. That for mercury has a still somewhat lower reduced temperature than has been reached with helium. All the curves agree in that the curvature is only very small; the greatest curvature with helium occurs at the higher temperatures. They deviate from each other in that the slope differs for the various substances. In the application of the law of corresponding states to normal substances account has to be taken of such systematic changes of the parameters of the laws for liquids: for substances with low critical point the slope of the line in the diagram decreases as the critical temperature decreases. In consideration of this it will be seen from the figure that helium satisfies this law in its generalised form; in particular the slope is compatible with that of *Ar*, *Ne* and *H*, the small curvature at higher reduced temperatures also falling into line. An extrapolation that can be accepted as a probable one, is that which is obtained by assuming the tangent to the experimental curve at the point where this curve

ends, as its continuation. This has been drawn in the figure. It gives for the temperature corresponding to the limit of the evaporation pressure reached in 1910 the value $1^{\circ},15$ K. and for that dealt with here, which is the lowest temperature yet attained, $0^{\circ},82$ K.

Taking into account the uncertainty of the extrapolation it will be better to say that *the lowest temperature yet attained is some hundredths of a degree below $0^{\circ},9$ K.*

§ 15. **Conclusion.** — The question put above, whether we could descend below 1° K., is answered positively by this result. In round numbers we have progressed $\frac{1}{3}$ of a degree and one may say that if we could have gone further only $\frac{1}{6}$ of a degree, we should have arrived at the limit obtainable in the ordinary way with helium. A better idea than given by these small numbers is obtained perhaps, when we express the lowering of temperature by the ratio in which we have decreased the absolute temperature. While the passing from ordinary temperature to that of helium evaporating at 0,2 m.m. means a lowering in the ratio 250 to 1 and from the melting point of hydrogen to the helium temperature mentioned, one of 13 to 1, the present lowering is only one of 1,4 to 1 and a further reduction of 1,2 to 1 would be nearly the limit of what could be done with liquid helium. If it is considered that our knowledge of atomic structure renders improbable that another substance could be discovered, or obtained in another way, more volatile than helium, then the limit indicated, from which we are separated by only such a small amount, would seem an absolute one set to us in the obtaining of yet lower temperatures.

We cannot accept such a limit otherwise than as a provisional one. There are even now definite problems which require to be treated in the domain beyond the seemingly impenetrable barrier. A simple example is the question whether a metal such as gold can be made super-conductive by cooling it more than we have been able to do. This kind of problem reminds us of the problem of the liquefying of the permanent gases. They withstood the efforts of the great experimenter whose glorious name is

attached to your Society. Half a century later the liquefaction of hydrogen, the most incoërcible gas with which FARADAY had operated was the brilliant achievement of the latest of his successors in office at the Royal Institution: Sir JAMES DEWAR. We may feel sure that the difficulty which has now arisen in our way will be overcome also and that the first thing needed is long and patient investigation of the properties of matter at the lowest temperature we can reach.
