

But whatever value is attached to the numerical evidence by those competent to judge, the broad conclusion from the *direction* of the changes is unaffected.

I should like also to reply to one criticism which has been made. It is not necessary to the hypothesis that the atomic free frequency should be absolutely invariable throughout all chemical changes. If it were the case that a slight change (say 1 per cent.) in the atomic free frequency would account for all the observed changes of refractivity and dispersion, the criticism would have force. But any one who examines the figures in the table for (*e. g.*) hydrogen, nitrogen, and ammonia, will see that no slight change in a frequency can possibly account for the observed changes. For hydrogen  $n_0^2 \times 10^{-27} = 12409$ , for nitrogen 17095. For ammonia the number which expresses its average value is 8135, an enormous drop. At the same time the refractivity has gone up only  $3\frac{1}{2}$  per cent. But if the number of vibrators had remained constant while the average free frequency decreased, the increase of the refractivity must have been much greater than this. Hence, to account for the observed changes, one must also assume that the number of vibrators (? electrons) has fallen off in about the same proportion as the frequency.

These two hypotheses seem much more improbable than that which is here put forward.

LXI. *The Laws of Deflexion of  $\alpha$  Particles through Large Angles\**. By Dr. H. GEIGER and E. MARSDEN †.

IN a former paper ‡ one of us has shown that in the passage of  $\alpha$  particles through matter the deflexions are, on the average, small and of the order of a few degrees only. In the experiments a narrow pencil of  $\alpha$  particles fell on a zinc-sulphide screen in vacuum, and the distribution of the scintillations on the screen was observed when different metal foils were placed in the path of the  $\alpha$  particles. From the distribution obtained, the most probable angle of scattering could be deduced, and it was shown that the results could be explained on the assumption that the deflexion of a single  $\alpha$  particle is the resultant of a large number of very small deflexions caused by the passage of the  $\alpha$  particle through the successive individual atoms of the scattering substance.

\* Communicated to *k. d.-k. Akad. d. Wiss. Wien*.

† Communicated by Prof. E. Rutherford, F.R.S.

‡ H. Geiger, Roy. Soc. Proc. vol. lxxxiii. p. 492 (1910); vol. lxxxvi. p. 235 (1912).

In an earlier paper \*, however, we pointed out that  $\alpha$  particles are sometimes turned through very large angles. This was made evident by the fact that when  $\alpha$  particles fall on a metal plate, a small fraction of them, about 1/8000 in the case of platinum, appears to be diffusely reflected. This amount of reflexion, although small, is, however, too large to be explained on the above simple theory of scattering. It is easy to calculate from the experimental data that the probability of a deflexion through an angle of  $90^\circ$  is vanishingly small, and of a different order to the value found experimentally.

Professor Rutherford † has recently developed a theory to account for the scattering of  $\alpha$  particles through these large angles, the assumption being that the deflexions are the result of an intimate encounter of an  $\alpha$  particle with a single atom of the matter traversed. In this theory an atom is supposed to consist of a strong positive or negative central charge concentrated within a sphere of less than about  $3 \times 10^{-12}$  cm. radius, and surrounded by electricity of the opposite sign distributed throughout the remainder of the atom of about  $10^{-8}$  cm. radius. In considering the deflexion of an  $\alpha$  particle directed against such an atom, the main deflexion-effect can be supposed to be due to the central concentrated charge which will cause the  $\alpha$  particle to describe an hyperbola with the centre of the atom as one focus.

The angle between the directions of the  $\alpha$  particle before and after deflexion will depend on the perpendicular distance of the initial trajectory from the centre of the atom. The fraction of the  $\alpha$  particles whose paths are sufficiently near to the centre of the atom will, however, be small, so that the probability of an  $\alpha$  particle suffering a large deflexion of this nature will be correspondingly small. Thus, assuming a narrow pencil of  $\alpha$  particles directed against a thin sheet of matter containing atoms distributed at random throughout its volume, if the scattered particles are counted by the scintillations they produce on a zinc-sulphide screen distance  $r$  from the point of incidence of the pencil in a direction making an angle  $\phi$  with it, the number of  $\alpha$  particles falling on unit area of the screen per second is deduced to be equal to

$$\frac{Qntb^2 \operatorname{cosec}^4 \phi/2}{16r^2},$$

where  $Q$  is the number of  $\alpha$  particles per second in the

\* H. Geiger and E. Marsden, Roy. Soc. Proc. vol. lxxxii. p. 495 (1909).

† E. Rutherford, Phil. Mag. vol. xxi. p. 669 (1911).

original pencil,  $n$  the number of atoms in unit volume of the material, and  $t$  the thickness of the foil. The quantity

$$b = \frac{2NeE}{mu^2},$$

where  $Ne$  is the central charge of the atom, and  $m$ ,  $E$ , and  $u$  are the respective mass, charge, and velocity of the  $\alpha$  particle.

The number of deflected  $\alpha$  particles is thus proportional to (1)  $\text{cosec}^4 \phi/2$ , (2) thickness of scattering material  $t$  if the thickness is small, (3) the square of the central charge  $Ne$  of the atoms of the particular matter employed to scatter the particles, (4) the inverse fourth power of the velocity  $u$  of the incident  $\alpha$  particles.

At the suggestion of Prof. Rutherford, we have carried out experiments to test the main conclusions of the above theory. The following points were investigated:—

- (1) Variation with angle.
- (2) Variation with thickness of scattering material.
- (3) Variation with atomic weight of scattering material.
- (4) Variation with velocity of incident  $\alpha$  particles.
- (5) The fraction of particles scattered through a definite angle.

The main difficulty of the experiments has arisen from the necessity of using a very intense and narrow source of  $\alpha$  particles owing to the smallness of the scattering effect. All the measurements have been carried out by observing the scintillations due to the scattered  $\alpha$  particles on a zinc-sulphide screen, and during the course of the experiments over 100,000 scintillations have been counted. It may be mentioned in anticipation that all the results of our investigation are in good agreement with the theoretical deductions of Prof. Rutherford, and afford strong evidence of the correctness of the underlying assumption that an atom contains a strong charge at the centre of dimensions, small compared with the diameter of the atom.

#### (1) *Variation of Scattering with Angle.*

We have already pointed out that to obtain measurable effects an intense pencil of  $\alpha$  particles is required. It is further necessary that the path of the  $\alpha$  particles should be in an evacuated chamber to avoid complications due to the absorption and scattering of the air. The apparatus used is shown in fig. 1, and mainly consisted of a strong cylindrical metal box  $B$ , which contained the source of  $\alpha$  particles  $R$ .

the scattering foil F, and a microscope M to which the zinc-sulphide screen S was rigidly attached. The box was fastened down to a graduated circular platform A, which could be rotated by means of a conical airtight joint C. By rotating the platform the box and microscope moved with it, whilst the scattering foil and radiating source remained in position, being attached to the tube T, which was fastened to the standard L. The box B was closed by the ground-glass plate P, and could be exhausted through the tube T.

Fig. 1.

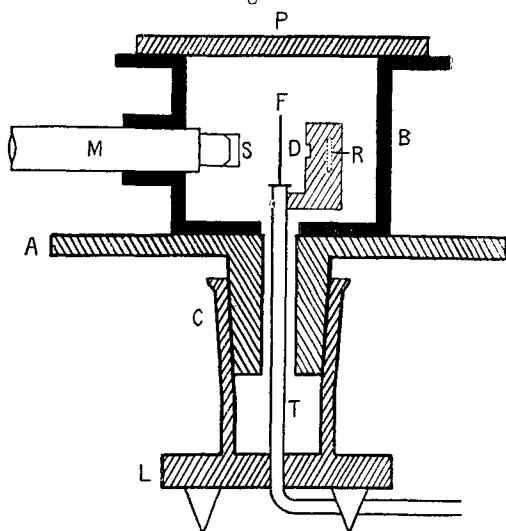

The source of  $\alpha$  particles employed was similar to that used originally by Rutherford and Royds\* in their experiments on the nature of the  $\alpha$  particle. It consisted of a small thin-walled glass tube about 1 mm. in diameter, containing a large quantity of well purified radium emanation. The  $\alpha$  particles emitted by the emanation and its active deposit could pass through the glass walls without much reduction of range. For these experiments the unhomogeneity of the source, due to the different  $\alpha$  particles from the emanation, Ra A and Ra C, does not interfere with the application of the law of scattering with angle as deduced from the theory, as each group of  $\alpha$  particles is scattered according to the same law.

By means of a diaphragm placed at D, a pencil of  $\alpha$  particles was directed normally on to the scattering foil F. By

\* E. Rutherford and T. Royds, *Phil. Mag.* vol. xvii. p. 281 (1909).

rotating the microscope the  $\alpha$  particles scattered in different directions could be observed on the screen S. Although over 100 millicuries of radium emanation were available for the experiments, the smallness of the effect for the larger angles of deflexion necessitated short distances of screen and source from the scattering foil. In some experiments the distance between the source and scattering foil was 2.5 cm., and the screen moved in a circle of 1.6 cm. radius, while in other experiments these distances were increased. Observations were taken in various experiments for angles of deflexion from  $5^\circ$  to  $150^\circ$ . When measuring the scattering through large angles the zinc-sulphide screen had to be turned very near to the source, and the  $\beta$  and  $\gamma$  rays produced a considerable luminescence on it, thus making countings of the scintillations difficult. The effect of the  $\beta$  rays was reduced as far as possible by enclosing the source in a lead box shown shaded in the diagram. The amount of lead was, however, limited by considerations of the space taken up by it, and consequently observations could not be made for angles of deflexion between  $150^\circ$  and  $180^\circ$ .

In the investigation of the scattering through relatively small angles the distances of source and screen from the scattering foil were increased considerably in order to obtain beams of smaller solid angle.

The number of particles scattered through different angles was found to decrease extremely rapidly with increase of angle, and as it is not possible to count with certainty more than 90 scintillations per minute or less than about 5 per minute, measurements could only be made over a relatively small range of angles at the same time. The number of  $\alpha$  particles scattered through large angles was first measured, and as the emanation decayed it was possible to take measurements for smaller and smaller angles, and from the known decay of the emanation measurements taken at different times could be corrected for the decrease of activity.

Even when no scattering foil was used a few scintillations were always observed on the screen. They were obviously due to scattered radiation from the walls of the vessel and from the edge of the diaphragm limiting the beam. The effect was reduced as far as possible by lining the box with paper and by using a substance of low atomic weight, viz. aluminium, for the diaphragm. The number of stray  $\alpha$  particles was determined for different positions of the microscope by removing the scattering foil so that the necessary corrections could be applied with certainty.

In order to make the best use of the emanation available,

measurements were made simultaneously with different foils. These foils were attached to frames which fitted into a slot in the tube T in such a way that they could be exchanged and accurately replaced in position. Table I. gives an example of a particular set of countings, when a silver foil was used to scatter the  $\alpha$  particles.

TABLE I.—Variation of Scattering with Angle. (Example of a set of measurements.) Silver Foil. Time elapsed since filling of emanation tube, 51 hours. Correction for decay, 0.683.

Angle $\phi$ .	Scintillations per minute.				$\frac{1}{\sin^4 \phi/2}$	$N \times \sin^4 \phi/2$ .
	Without foil.	With foil.	Corrected for effect without foil.	Corrected for decay, N.		
150...	0.2	4.95	4.75	6.95	1.15	6.0
135 ..	2.6	8.3	5.7	8.35	1.38	6.1
120...	3.8	10.3	6.5	9.5	1.79	5.3
105...	0.6	10.6	10.0	14.6	2.53	5.8
75...	0.0	28.6	28.6	41.9	7.25	5.8
60...	0.3	69.2	68.9	101	16.0	6.3

In this set about 2500 scintillations were counted. After a few days had elapsed the measurements for the smaller angles were repeated and the range of angles extended. Proceeding in this way the whole range of angles was investigated in the course of a few weeks. When measuring relatively large angles of deflexion a wide beam of about 15° radius had to be used in order to obtain a suitable number of scintillations, but for the smaller angles the aperture of the diaphragm confining the beam was reduced considerably, so that the angle at which the scintillations were counted was always large compared with the angular radius of the beam. When changing over from one diaphragm to another comparative measurements for different angles were made so as to obtain an accurate value of the reduction constant.

Table II. gives the collected results for two series of experiments with foils of silver and gold. The thicknesses of the foils were in the first series equivalent to 0.45 and 0.3 cm. air, and in the second series 0.45 and 0.1 cm. air for silver and gold respectively. Col. I. gives the values of the

TABLE II.  
Variation of Scattering with Angle. (Collected results.)

I. Angle of deflexion, $\phi$ .	II.	III. SILVER.		V. GOLD.	
	1 $\sin^4 \phi/2$	Number of scintil- lations, N.	$\frac{N}{\sin^4 \phi/2}$	Number of scintil- lations, N.	$\frac{N}{\sin^4 \phi/2}$
150 .....	1.15	22.2	19.3	33.1	28.8
135 .....	1.38	27.4	19.8	43.0	31.2
120 .....	1.79	33.0	18.4	51.9	29.0
105 .....	2.53	47.3	18.7	69.5	27.5
75 .....	7.25	136	18.8	211	29.1
60 .....	16.0	320	20.0	477	29.8
45 .....	46.6	989	21.2	1435	30.8
37.5 .....	93.7	1760	18.8	3300	35.3
30 .....	223	5260	23.6	7800	35.0
22.5 .....	690	20300	29.4	27300	39.6
15 .....	3445	105400	30.6	132000	38.4
30 .....	223	5.3	0.024	3.1	0.014
22.5 .....	690	16.6	0.024	8.4	0.012
15 .....	3445	93.0	0.027	48.2	0.014
10 .....	17330	508	0.029	200	0.0115
7.5 .....	54650	1710	0.031	607	0.011
5 .....	276300	...	...	3320	0.012

angles  $\phi$  between the direction of the beam and the direction in which the scattered  $\alpha$  particles were counted. Col. II. gives the values of  $\frac{1}{\sin^4 \phi/2}$ . In Cols. III. and V. the numbers of scintillations are entered which were observed for the silver and gold respectively. Corrections are made for the decay of the emanation, for the natural effect, and for change of diaphragm. For the smaller angles corrections have been applied (in no case exceeding 20 per cent.) owing to the fact that the beam of  $\alpha$  particles was of finite dimensions and not negligible compared with the angle of deflexion. These corrections were calculated from geometrical considerations. In Cols. IV. and VI. the ratios of the numbers of scintillations to  $\frac{1}{\sin^4 \phi/2}$  are entered. It will be seen that in both sets the values are approximately constant. The deviations are somewhat systematic, the ratio increasing with decreasing angle. However, any slight asymmetry in the apparatus and other causes would affect the results in a systematic way so that, fitting on the two sets of observations and considering the enormous variation in the numbers of scattered particles, from 1 to 250,000, the deviations from constancy of the ratio are probably well within the experimental

error. The experiments, therefore, prove that the number of  $\alpha$  particles scattered in a definite direction varies as  $\text{cosec}^4 \phi/2$ .

#### Variation with Thickness of Material.

In investigating the variation of scattering with thickness of material, it seemed necessary to use a homogeneous source of  $\alpha$  particles, for according to the theory the effect of the change of velocity with increasing thickness will be very appreciable for  $\alpha$  particles of low velocity. In the experiments on "compound scattering" by one of us, a source was used consisting of Ra C deposited from radium emanation *in situ* in a small conical tube fitted with a mica window, the emanation being withdrawn when measurements were taken by expanding into a large volume connected to it. In our first experiments we used such a source, but the observations eventually showed it to be unsuitable. After expansion some emanation remains clinging to the walls of the glass tube. This emanation and the Ra A associated with it gives  $\alpha$  particles of considerably lower velocity than the  $\alpha$  particles of Ra C, and although the number of  $\alpha$  particles so contributed was of the order of only a few per cent. of the number from the Ra C, yet owing to the fact that the amount of scattering increases very rapidly with decreasing velocity, the disturbances caused by the slower  $\alpha$  particles were so large as to render the source unsuitable for the present work.

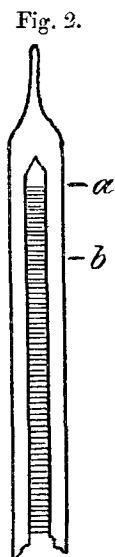

The source finally adopted was prepared as shown in fig. 2. About 80 millicuries of radium emanation were very highly purified and pressed into the conical end of the glass tube T of about 1 mm. internal diameter. After the emanation had remained in position for a sufficient time to attain equilibrium with Ra C, it was expanded into a bulb below, and a small part of the capillary tube was drawn off at *b*. About 1 mm. of the end of the tube which was coated with the Ra C was then cut off (at *a*) and freed from occluded emanation by washing with alcohol and by heating. The resulting source of Ra C was used in the experiments, and with due care its decay was found to be in agreement with theory, at least for the first 80 minutes.

The arrangement used for the comparison of the scattering



of different thicknesses of metal foils is shown diagrammatically in fig. 3. It consists essentially of a source of  $\alpha$  radiation R, a diaphragm D, a scattering foil F, and a zinc-sulphide screen Z on which the scattered  $\alpha$  particles were observed. The main part of the apparatus was enclosed in a cylindrical brass ring A, the ends of which were planed so that they could be closed airtight by the two glass plates B and C. The depth of the ring was 3.5 cm., and its internal and external diameters 5.5 and 7.5 cm. respectively. Two holes were drilled through the glass plate B, one in the centre and the other 1.65 cm. eccentric. The source of radiation R was placed directly against a sheet of mica which was waxed over and closed the opening E. By placing the source outside the apparatus, any small amount of emanation associated with it was prevented from entering the chamber and disturbing the measurements.

Fig. 3.

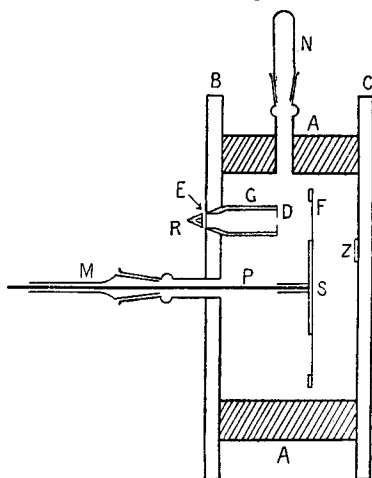

By means of the diaphragm D a narrow pencil of  $\alpha$  particles could be directed on to the scattering foil. The different foils were attached to the disk S and covered five of six holes drilled through it at equal distances from its centre. The uncovered opening was used to determine the natural effect. The disk could be fitted on to the rod P, which was fastened to the ground-glass joint M so that it could be rotated and the different foils brought in front of the diaphragm. The scattered  $\alpha$  particles were observed by means of a microscope on the zinc-sulphide screen Z fixed inside the glass plate.

In making the observations the disk carrying the foils was placed in position about 1.2 cm. from the glass plate C. The apparatus was then completely exhausted through a tube not shown in the diagram, charcoal cooled by liquid air being used for the final exhaustion. After the source of radiation had been placed in position, the microscope was adjusted at that part of the zinc-sulphide screen where the scintillations appeared at a rate convenient for counting. With a source of 30 millicuries of Ra C this was usually the case for an angle of deflexion of from  $20^\circ$  to  $30^\circ$ . The area of the screen visible through the microscope was about 1 sq. mm., whilst the main beam of  $\alpha$  particles covered an area of about 3 sq. mm.

As soon as the Ra A in the source had decayed completely (*i. e.* after 20 minutes) countings were commenced. Measurements were first taken with the layers of foils of smaller thickness, and as the source decayed they were extended to the thicker foils. From the known decay of the active deposit of radium the measurements could all be corrected for the variation in activity of the source, the results being verified by making observations on the same foils at different times. An experiment generally extended for about 80 minutes. After that time the decay corrections for the source were not always reliable owing to small quantities of radium emanation associated with it, as has been mentioned above. Owing to the relatively short time available in each experiment for the completion of the measurements, only about 100 to 200 scintillations could be counted with each foil.

As in the experiments on the variation of scattering with angle, some scintillations appeared on the zinc-sulphide screen even when no scattering foil was interposed. It was found that these scintillations were due to  $\alpha$  particles which had been scattered from the edges of the diaphragm limiting the beam. Experiments were made with paper diaphragms and with aluminium diaphragms of only  $\frac{1}{10}$  mm. thickness, whilst a diaphragm D' (fig. 4) was also introduced to prevent scattering from the inside of the glass tube G carrying the main diaphragm D. Even with these precautions the effect was still so large that accurate experiments with foils of low atomic weight would have been impossible. The difficulty was, however, successfully overcome by intercepting the stray  $\alpha$  particles by a screen K, which could be turned by means of a ground-glass joint (N in fig. 3) about a vertical axis passing through A so as to be just outside the main pencil. The adjustment was made by observation of the scintillations produced by the main beam on the zinc-sulphide

screen Z, which was temporarily placed at Z'. The magnitude of the effect may be judged from the following figures obtained in a particular experiment with an aluminium diaphragm :—The number of scintillations without both the screen K and the scattering foil F was 60 per minute, whilst by bringing the screen K into position the number was reduced to 0.5 per minute. With the screen K in position and an aluminium foil equivalent to 0.5 cm. air as scattering foil, the number of scintillations was 14 per minute, or about one quarter the effect without screen or scattering foil.

Fig. 4.

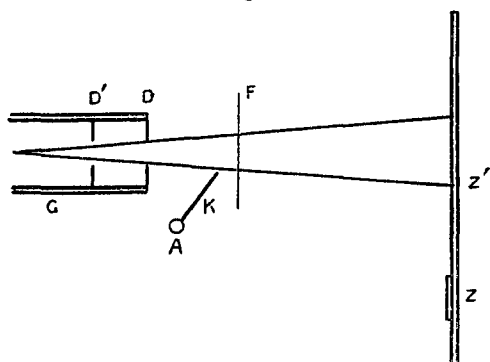

In the following table the results of an experiment with gold foils are tabulated. Column I. gives the number of foils and column II. the thicknesses expressed as the stopping power of  $\alpha$  particles in centimetres of air as determined by the scintillation method. The figures given in column III. represent the number of scintillations observed on the zinc-sulphide screen. These figures are corrected for the variation of activity with time of the source. A slight correction has been made due to the increase of scattering on account of the decrease of velocity of the  $\alpha$  particles in passing through the foils. The magnitude of this correction could be calculated from the results given in the last section of the present paper, and amounted to 9 per cent. in this experiment for the thickest foil used. The last column of the table gives the ratio of the corrected number of scintillations to the thickness. The values are constant within the limits of the experimental error. The variations exhibited by the figures are well within the probability errors, owing to the relatively small number of scintillations which could be counted in the time available.

TABLE III.

Gold.—Variation of Scattering with Thickness.

I.	II.	III.	IV.
Number of Foils.	Air equivalent. T in cm.	Number N of scintillations per minute.	Ratio $\frac{N}{T}$ .
1	0.11	21.9	200
2	0.22	38.4	175
5	0.51	84.3	165
8	0.81	121.5	150
9	0.90	145	160

Similar experiments were carried out with foils of tin, silver, copper, and aluminium. In each set about 1000 scintillations were counted. The results are plotted in fig. 5, where the abscissæ represent the thickness of the scattering foil expressed in centimetres of air equivalent and the ordinates the number of scattered particles. Similar corrections to the above have been introduced in each case.

Fig. 5.

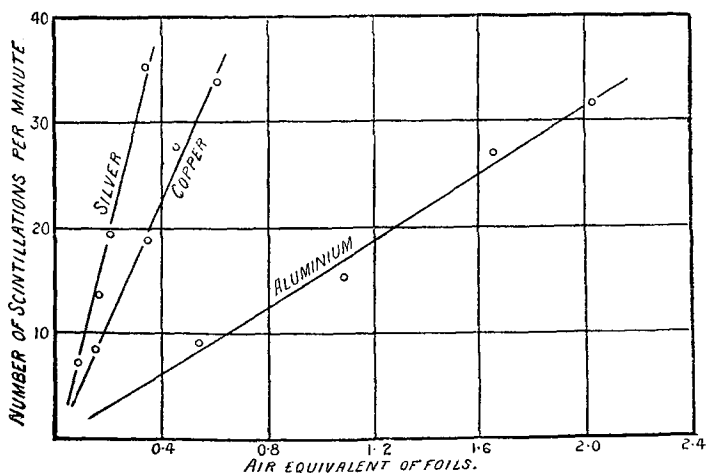

For all the metals examined the points lie on straight lines which pass through the origin. The experiments therefore prove that for small thicknesses of matter the scattering is proportional to the thickness. If there is any appreciable

diminution in velocity of the  $\alpha$  particles in passing through the foils, the number of scattered particles increases somewhat more rapidly than the thickness.

*Variation with Atomic Weight.*

Assuming that the magnitude of the central charge of the atom is proportional to the atomic weight  $A$ , Professor Rutherford has shown that the number of  $\alpha$  particles scattered by different foils containing the same number of atoms should be proportional to  $A^2$ . With the thin foils which had to be used experimentally, it was found impracticable to calculate the number of atoms per unit area by weighing the foils. It proved much more reliable to deduce the required number of atoms from the air equivalent as found by the reduction of the range of  $\alpha$  particles by the scintillation method. This method had the advantage that the thickness was determined at the exact part of the foil which served to scatter the  $\alpha$  particles, thus eliminating any errors due to variations in the thickness of the foils. Bragg and others have given numbers connecting the thicknesses of foils of various materials and their stopping power, and it has been shown that for different foils of the same air equivalent the numbers of atoms per unit area are inversely proportional to the square roots of the atomic weights. Consequently if the scattering per atom of atomic weight  $A$  is proportional to  $A^2$ , the scattering per centimetre air equivalent will be proportional to  $A^2 \times A^{-\frac{1}{2}}$ , *i. e.* to  $A^{3/2}$ .

In the experimental investigation the same apparatus was used as in the previous experiments on the variation of scattering with thickness of material. The openings in the disk  $S$  were covered with thin foils of different materials, and their thicknesses chosen in such a way that they gave approximately the same effect of scattering. A number of different sets of experiments were made, the foils being varied in each experiment. The results in a particular experiment are given in Table IV. Columns I. and II. give the foils used and their respective atomic weights. In column III. the air equivalents of the foils are entered. Column IV. gives the number of scintillations observed after correction for the variation in activity of the source and the loss of velocity of the  $\alpha$  particles in the foil. Column V. gives the number of scintillations per unit air equivalent of material. In column VI. the values of  $A^{3/2}$  are given, and in column VII. the ratios of the numbers of scintillations to  $A^{3/2}$  are calculated. The figures are constant within the experimental error.

TABLE IV.

Variation of Scattering with Atomic Weight. (Example of a set of measurements.)

I. Substance.	II. Atomic weight. A.	III. Air equivalent in cm.	IV. Number of scintillations per minute corrected for decay.	V. Number N of scintillations per cm. air equivalent.	VI $A^{3/2}$ .	VII. $N \times A^{2/3}$ .
Gold .....	197	·229	133	581	2770	0·21
Tin .....	119	·441	119	270	1300	0·21
Silver .....	107·9	·262	51·7	198	1120	0·18
Copper .....	63·6	·616	71	115	507	0·23
Aluminium..	27·1	2·05	71	34·6	141	0·24

The combined results of four experiments are given in Table V. In the last column are given the ratios of the numbers of scintillations per centimetre equivalent to  $A^{3/2}$ . This ratio should be constant according to theory. The experimental values show a slight increase with decreasing atomic weight.

TABLE V.

Variation of Scattering with Atomic Weight. (Collected results using Ra C.)

Substance.	Total number of scintillations counted for each material.	$A^{3/2}$ .	Ratio of scintillations per cm. air equivalent to $A^{3/2}$ *.
Gold .....	850	2770	95
Platinum .....	200	2730	99
Tin .....	700	1300	96
Silver .....	800	1120	98
Copper .....	600	507	104
Aluminium .....	700	144	110

\* Note 1.—Since these experiments were carried out, Richardson and one of us (Phil. Mag. vol. xxv. p. 184 (1913)) have determined the masses per unit area per cm. air equivalent for different metals, using the scintillation method. Introducing the results, and calculating the values of the ratio of the scattering per atom divided by  $A^2$ , the following are obtained:—Au 3·4, Pt 3·2, Sn 3·3, Ag 3·6, Cu 3·7, Al 3·6. These numbers show better agreement than those in the last column above, which are calculated on the assumption of Bragg's law.

On account of the importance of these experiments further measurements were made under somewhat different conditions. The main difficulty in the previous experiments arose from the fact, that owing to the rapid decay of the source it was impossible to count in each case a sufficient number of scintillations to obtain a true average value. In the following set of measurements radium emanation in equilibrium with its active deposit was used as source of radiation. The source consisted of a conical glass tube (fig. 6) of about  $1\frac{1}{2}$  mm. internal diameter at its widest part, the height of the cone being about 2.5 mm. The end of the tube was closed airtight by a sheet of mica of 0.62 cm. air equivalent. This tube was filled with about 30 millicuries of highly purified emanation and placed at R (fig. 3, p. 612) directly against the mica window E, the air equivalent of which was also 0.62 cm.

Fig. 6.

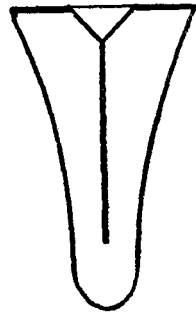

The difficulty introduced by the employment of  $\alpha$  particles of different velocities (emanation, Ra A, and Ra C) was eliminated by using foils of approximately the same air equivalent. The  $\alpha$  particles therefore suffered the same reduction in velocity in each foil, and the numbers of scattered particles were therefore directly comparable. It was of course impossible to obtain foils of exactly the same air equivalent, but this difficulty was easily overcome by determining the scattering for two foils of the same material, one slightly smaller and the other slightly larger than a standard thickness of 0.6 cm. air equivalent.

Owing to the large variation with atomic weight of the amount of scattering, the foils could not be all directly compared with each other at the same angle. They were therefore compared in sets, the angle being chosen smaller for the sets of lower atomic weight. Column VI. in the following table gives the mean results of the ratio of the number of scattered particles to  $A^{3/2}$ .

The scattering of carbon was obtained by using thin sheets of paraffin wax which contained about 85.2 per cent. carbon and 14.8 per cent. hydrogen. The air equivalent of the carbon was calculated from Bragg's law to be about 78 per cent. of the whole stopping power, and on account of the low atomic weight of hydrogen all the scattering effect was assumed due to the carbon. The measurements of the scattering were made by comparison with that due to aluminium foils of the same air equivalent.

TABLE VI.

Variation of Scattering with Atomic Weight. (Collected results using Radium emanation.)

I. Substance.	II. Air equivalents of foils used.	III. Total number of scintillations counted for each substance.	IV. Number N of scintillations at same angle and for same air equivalent.	V. $A^{3/2}$ .	VI. $N \times A^{2/3}$
Gold .....	.52, .68	1200	2400	2770	.85
Platinum .....	.54, .625	1000	2900	2730	1.05
Tin .....	.51, 1.15	1400	1290	1300	.99
Silver .....	.38, .435	600	1060	1120	.95
Copper .....	.495, .61	1300	570	507	1.12
Aluminium ...	.45, .52, 1.06	1600	151	144	1.05
Carbon .....	.55, .57	400	57	41.6	1.37

Note 2.—Introducing the new data for the mass per unit area of foils of the same air equivalent, as in note 1, the following are the values for the ratio of the scattering per atom divided by  $A^2$ :—Au 3.1, Pt 3.4, Sn 3.4, Ag 3.4, Cu 3.95, Al 3.4.

It will be seen from the table that, although the experimental conditions were very different from those in the previous experiments, the results are similar, and indicate the essential correctness of the assumption that the scattering per atom is proportional to the square of the atomic weight. The deviations from constancy of the ratio (see notes 1 and 2) are nearly within the experimental error.

The measurements have not so far been extended to substances of lower atomic weight than carbon. When the atomic weight is small and comparable with the mass of the  $\alpha$  particle, the laws of scattering will require some modification to take into account the relative motion of the atom itself when a collision occurs.

#### *Variation of Scattering with Velocity.*

In order to determine the variation of scattering with velocity the apparatus was somewhat modified. A conical glass tube coated with active deposit was again used as source of radiation. This source was placed about 1 mm. from the mica window (E, fig. 3), so that it was possible to insert additional sheets of mica between the source and the window to reduce the velocity of the  $\alpha$  particles. Mica sheets were used for this purpose on account of their uniformity of



thickness in comparison with metal foils. The micas were attached to a cardboard disk which could be rotated to bring the different sheets successively in position. The  $\alpha$  particles were scattered by a foil of gold or silver, of stopping power about 3 mm. of air, which was attached to a rod passing through the ground glass N. This made it possible to turn the foil away from the main beam during an experiment in order to test the natural effect. The disk S, in this case, rotated in a plane very close to the glass plate C and carried sheets of mica of different thicknesses. By rotating the ground-glass joint the micas could be placed directly in front of the zinc-sulphide screen, making it possible to test the homogeneity of the  $\alpha$  particles after they had been scattered.

The results are given in Table VII. Column I. gives the number of mica sheets which were interposed in addition to the mica window, and column II. the ranges of the  $\alpha$  particles incident on the scattering foil. The values of the velocities  $v$  were calculated from these ranges R by use of the formula  $v^3 = aR$  previously found by one of us\*. The relative values

TABLE VII.

Variation of Scattering with Velocity.

I.	II.	III.	IV.	V.
Number of sheets of mica.	Range R of $\alpha$ particles after leaving mica.	Relative values of $1/v^4$ .	Number N of scintillations per minute.	$Nv^4$ .
0	5.5	1.0	24.7	25
1	4.76	1.21	29.0	24
2	4.05	1.50	33.4	22
3	3.32	1.91	44	23
4	2.51	2.84	81	28
5	1.84	4.32	101	23
6	1.04	9.22	255	28

of  $1/v^4$  are given in column III. The number of scintillations per minute N are entered in column IV., and in column V. relative values of  $N \times v^4$  are given. Over the range examined the number of scintillations varies in the ratio 1:10, while it will be seen that the product  $Nv^4$  remains sensibly constant. Several experiments were made, and in every case

\* H. Geiger, Roy. Soc. Proc. A. vol. lxxxiii. p. 506 (1910).

the scattering was found to vary at a rate more nearly proportional to the inverse fourth power of the velocity than to any other integral power. Owing to the comparative uncertainty of the values of the velocity for small ranges, however, the error of experiment may be somewhat greater than appears from column V. of the table.

In these experiments it proved essential to use a source possessing a high degree of homogeneity. In earlier experiments, where we were not able to fulfil this condition, the scattering apparently increased much more rapidly than the inverse fourth power of the velocity of the Ra C  $\alpha$  particles. Even with a source of Ra C with which only a small quantity of emanation was associated, the amount of scattering first rapidly increased on interposing the sheets of mica, then showed a slight decrease, and finally increased again. This irregularity was due to the  $\alpha$  particles of the emanation and Ra A, which are of shorter range than those of Ra C, and therefore more easily scattered.

The measurements could not easily be extended to  $\alpha$  particles of lower velocity than corresponds to a range of about 1 centimetre, owing to the difficulty of observing the faint scintillations at lower ranges. However, in one particular experiment, by adding sheets of mica to cut down the velocity the number of scattered  $\alpha$  particles appearing on the screen was increased 25 times, showing how easily the  $\alpha$  particles of low velocity are scattered.

The results of the examination of the homogeneity of the scattered  $\alpha$  particles showed that at least in the case of gold they remained practically homogeneous after the scattering. Experiments of this nature in the case of scattering foils of low atomic weight would be very interesting, but are somewhat difficult.

*Determination of Absolute Number of Scattered  
 $\alpha$  Particles.*

In the previous sections we have completely verified the theory given by Prof. Rutherford. Since, according to this theory, the large deflexion of an  $\alpha$  particle is the result of a close encounter with a single atom of matter, it is possible to calculate the magnitude of the central charge of the atom when the fraction of  $\alpha$  particles scattered under definite conditions is determined. We have made several attempts under different conditions to obtain a quantitative estimate of the scattered particles, but the results so far have only given us an approximate value. The main difficulty arises from the fact that the scattered particles consist of such a small

fraction of the original beam that different methods of measurement have to be employed in the two cases. The number of scattered  $\alpha$  particles was determined from the number of scintillations observed on the zinc-sulphide screen, a correction being necessary owing to the fact that with the particular screens used only about 85 per cent. of the incident  $\alpha$  particles produce scintillations. The number of  $\alpha$  particles in the main beam was in one case in which an emanation tube was used (as shown in fig. 1, p. 607) determined directly by the scintillation method, several weeks being allowed to elapse, so that the emanation had decayed to a small value. In other experiments Ra C deposited on the inside of a conical glass tube (as in fig. 2, p. 611) was used, and the number of  $\alpha$  particles was calculated from its  $\gamma$ -ray activity and the distance and area of the diaphragm determining the beam.

The results showed that, using a gold foil of air equivalent 1 mm. (actual thickness  $2.1 \times 10^{-5}$  cm.), the fraction of incident Ra C  $\alpha$  particles ( $v = 2.06 \times 10^9$  cm./sec.) scattered through an angle of  $45^\circ$  and observed on an area of 1 sq. mm. placed normally at a distance of 1 cm. from the point of incidence of the beam, was  $3.7 \times 10^{-7}$ . Substituting this value in the equation given at the commencement of this paper, it can be calculated that the value of the number of elementary electric charges composing the central charge of the gold atom is about half the atomic weight. This result is probably correct to 20 per cent., and agrees with the deduction of Prof. Rutherford from the less definite data given in our previous paper.

From the results of this and the previous sections it is possible to calculate the probability of an  $\alpha$  particle being scattered through any angle under any specified conditions. For materials of atomic weight greater than that of aluminium, it is sufficiently accurate to put  $N$  equal to half the atomic weight in the equation given at the commencement of the paper.

It will be seen that the laws of "single scattering" found in this paper are quite distinct from the laws of "compound scattering" previously deduced by Geiger. It must be remembered, however, that the experiments are not directly comparable. In the present paper we are dealing with very thin sheets of matter, and are measuring the very small fraction of  $\alpha$  particles which are deflected by single collisions through relatively large angles. The experiments of Geiger, however, deal with larger thicknesses of scattering foils and angles of deflexion of a few degrees only. Under these conditions the scattering is due to the combination of a large number of deflexions not only by the central charges of the

atoms, but probably also by the electronic charges distributed throughout the remainder of their volumes.

*Summary.*

The experiments described in the foregoing paper were carried out to test a theory of the atom proposed by Prof. Rutherford, the main feature of which is that there exists at the centre of the atom an intense highly concentrated electrical charge. The verification is based on the laws of scattering which were deduced from this theory. The following relations have been verified experimentally:—

(1) The number of  $\alpha$  particles emerging from a scattering foil at an angle  $\phi$  with the original beam varies as  $1/\sin^4 \phi/2$ , when the  $\alpha$  particles are counted on a definite area at a constant distance from the foil. This relation has been tested for angles varying from  $5^\circ$  to  $150^\circ$ , and over this range the number of  $\alpha$  particles varied from 1 to 250,000 in good agreement with the theory.

(2) The number of  $\alpha$  particles scattered in a definite direction is directly proportional to the thickness of the scattering foil for small thicknesses. For larger thicknesses the decrease of velocity of the  $\alpha$  particles in the foil causes a somewhat more rapid increase in the amount of scattering.

(3) The scattering per atom of foils of different materials varies approximately as the square of the atomic weight. This relation was tested for foils of atomic weight from that of carbon to that of gold.

(4) The amount of scattering by a given foil is approximately proportional to the inverse fourth power of the velocity of the incident  $\alpha$  particles. This relation was tested over a range of velocities such that the number of scattered particles varied as 1 : 10.

(5) Quantitative experiments show that the fraction of  $\alpha$  particles of Ra C, which is scattered through an angle of  $45^\circ$  by a gold foil of 1 mm. air equivalent ( $2.1 \times 10^{-5}$  cm.), is  $3.7 \times 10^{-7}$  when the scattered particles are counted on a screen of 1 sq. mm. area placed at a distance of 1 cm. from the scattering foil. From this figure and the foregoing results, it can be calculated that the number of elementary charges composing the centre of the atom is equal to half the atomic weight.

We are indebted to Prof. Rutherford for his kind interest in these experiments, and for placing at our disposal the large quantities of radium emanation necessary. We are also indebted to the Government Grant Committee of the Royal Society for a grant to one of us, out of which part of the expenses has been paid.