

Competitive Advantages of a Firm without Fundamental Technology: A Case Study of Sony, Casio and Nintendo

Kiyohiro Yamazaki

Abstract—A purpose of this study is to examine how a firm without fundamental technology is able to gain the competitive advantage. This paper examines three case studies, Sony in the flat display TV industry, Casio in the digital camera industry and Nintendo in the home game machine industry. This paper maintain the firms without fundamental technology construct two advantages, economic advantage and organizational advantage. An economic advantage involves the firm can select either high-tech or cheap devices out of several device makers, and change the alternatives cheaply and quickly. In addition, organizational advantage means that a firm without fundamental technology is not restricted by organizational inertia and cognitive restraints, and exercises the characteristic of strength.

Keywords—Firm without fundamental technology, economic advantage, organizational advantage, Sony, Casio, Nintendo.

I. INTRODUCTION

THERE is several discussions on the relationship between the management resources and competitive advantage. Several scholars attempted to demonstrate that management resources are different across individual firms, and each firm's resources are an advantageous source for competition. This approach, which is called RBV (Resource-Based View of the Firm), points out that management resources and their abilities differ from one firm to another, and this heterogeneity leads to the differentiation of products and services [1], [2]. In particular, Prahalad and Hamel [3] paid attention to firm-specific management resources. They maintained that heterogeneity is important and argued that it is advantageous for competing firms. These resources should not be easily imitated by other firms for the heterogeneity of resources to exist. The resource that can be easily imitated and obtained by competitors is at once imitated by them [2]. Therefore, ambiguous causality [4], [5], path dependency [6], and a right to be protected legally and systematically [7] are required. In addition, researchers have argued that resources should not be freely transferred to other firms [8], [9]. Ambiguous causality and path dependency make market dealings of resources difficult.

As mentioned above, researchers have discussed that the possession of the core resource hinders the gaining of competitive advantage [10], while management resources

generate competitive advantage. Leonard-Barton [11] paid attention to the core capability as a source of a competitive firm's advantage. However, this capability is not versatile. It can be a burden to the firm if it does not lead to corporate competitiveness. A firm's corporate activity would be stiffened; the core capability becomes core rigidity.

A great deal of effort has been devoted to the fact that contemporary firms having core resources and capabilities gain the competitive advantage. However, the reasons that firms without core resources and capabilities also have this strength have not been studied in academic research. That the firms with the core technology construct competitive advantage and that the possession of the core technology hinders the competitive advantage of firms have been discussed. However, researchers have not sufficiently discussed the reasons firms without the same level of core technology can enhance competition.

From the practical perspective, it can be pointed out that industries where the firm is without core technology can demonstrate strength in recent years. Firms lacking core technology obtain core devices when those devices outside firms are significantly modularized [12], [13]. The most important addition to be made to what we have said about the firm without core technology is the forming of the global innovation network [14], [15]. The firm could cooperate with several international partners for creating new value. Therefore, the firms without fundamental technology could develop excellent products and gain their competitive advantage by using the global supply chain in industries that were dominated by firms with core technologies.

This paper then constructs the structure where firms without core technologies become competitive. Three cases - Sony, Casio and Nintendo - are the main focuses of this analysis.

For the aims of this research, a fundamental technology is defined as a resource for designing and producing core devices. The elemental technology is roughly parts into the fundamental technology and peripheral technology. The fundamental technology is a technology that satisfies two requirements. One requirement is a technology for working the "basic function" provided by a product. "Basic function" means its technology defines the product uses. Secondary, when each firm enters the market, fundamental technology is recognized as the technology comprising the cardinal part of the product, and fundamental technology determined by the overall industry. The set of manufacturers recognized its technology, and the

K. Yamazaki is with Chukyo University, Nagoya, Aichi 466-8666 Japan (e-mail: k-yamaza@mecl.chukyo-u.ac.jp).

timing for recognizing the fundamental technology is a fluid stage of the industry. Its technology is developed continually.

In several former researches [3], [11], “Core technology”, which is used to explain a firm’s competitive advantages, is a technology that is unique to the firm and has multiple uses with several products. On the other hand, fundamental technology in this research is defined by the industry.

There is a difference between the fundamental technology and the core technology. The core technology that Prahalad and Hamel [3] and Leonard-Barton [11] maintained is a technology that is original to the firm and has multiple uses with some products. Therefore, recognition of the fundamental technology is different from differentiating the respective core technologies in each firm. The fundamental technology in this research is determined in accordance with product features and a specific technology in a product, regardless of the firm’s idea. Therefore, the fundamental technology is a unique technology that is determined by the overall industry. The performance level of the basic function of product does not satisfy customer demand levels during the fluid periods of the industry, and the biggest product development task is for market expansion [17]. The product development focuses on an improvement of the function level of the fundamental technology.

II. CASE STUDY 1: SONY’S CASE

A. Ownership of Each Firm’s Fundamental Technology

Technology for panel devices is important because it can be said that the history of flat panel TV development is the same as the history of panel development, which is fundamental to displaying an image, the basic function of a television. During the R&D stage, several firms and research laboratories were working to develop a panel device to improve the flat panel TV. As per the flat panel TV industry’s consensus, reducing the thickness of the panel and improving its performance were recognized as a fundamental technological development task for product differentiation. This study, therefore, assumes that the panel device is the fundamental technology for the flat panel TV industry.

Most of the firms that promoted the development of flat panel TV industry and produced tube televisions have also developed technology for LCD and plasma TVs, as they were the next generation technologies that replaced the tube television in the 1990’s. It was Fujitsu, Hitachi, Pioneer, NEC, Panasonic, among others that commercialized the plasma TV. Overseas manufacturers, such as LG and Samsung were also instrumental in the development of the plasma TV. These firms keep their plasma panel factories separate.

Firms with LCD display factories, such as Sharp, Hitachi and Panasonic have developed the LCD TV. Other firms like Samsung, LG, and Philips also make LCD TVs, while Taiwanese manufacturers like AUO and CMO have gained the competitive advantage as liquid crystal panel manufacturers. However, firms like Sony, Toshiba, Mitsubishi, and Pioneer do not have panel device technology, and since Sony lacks both

the liquid crystal panel and the plasma panel technologies, we focus on Sony’s product development in this study (Fig. 1).

	LCD panel device	LCD TV	Plasma panel device	Plasma TV
Sony	x → Δ (Samsung)	○	x	○ → x
Toshiba	○ (+Pa/H) → x	○	x	x
Panasonic	○ (+T/H)	○	○	○
Hitachi	○ (+T/Pa)	○	○ (+F) → ○	○
Mitsubishi	x	○	x	x
Sharp	○	○	x	○ → x
Pioneer	x	x	○ → x	○
Samsung	○	○	○	○
LG	○ (+Ph)	○	○	○
Phillips	○ (+LG)	○	x	○
AUO	○	○	x	x
CMO	○	○	x	x

Panel device ○: own, Δ: joint concern, x: not own TV ○: develop, x: not develop

Fig. 1 Ownership of fundamental technology in flat panel TV firms

It is thought that product development influences decision-making and action taken by the flat panel TV industry; therefore, it is necessary to review Sony’s activities before the company entered the flat panel TV industry. Sony produced a tape-recorder in 1950, a transistor radio in 1955, and the first transistor television in the world in 1960. They developed the Trinitron color television, which was released into the market in 1968. Later innovative products included the beta method VTR, the Walkman CD player, the eight-millimeter camcorder, and the PlayStation (a family game machine).

The ideas behind the development of these products were to develop an original product based on new technology, to miniaturize, to decrease product weight, and to create an excellent design. The product mindset formed in Sony through the development of these products was “originality, compactness, and design.” Throughout its history, Sony has also built up high-density surface-mounting technology and design knowledge.

B. Flat Panel TV Developments in Sony

Fujitsu had concentrated on developing the plasma television, as Sharp did with the LCD TV, and released their products to rapidly become popular alternatives to the tube television. This led to Sony being shut out of the growing flat panel TV market.

However, even without panel device technology, Sony was developing products that supported its features. The first of the four characteristics of the flat panel TV was its low cost. A product with the same performance had been produced as a cheaper television by procuring a low-cost panel. Second, they have many variations, including different screen sizes and features, which Sony developed by procuring various panels. Third, they combine two or more technological systems. Sony developed a product with two or more technological systems, such as LCD and plasma TVs. Fourth, flat panel TVs are differentiated by factors other than the display panel, such as excellent exterior design.

As a result, Sony gained competitive advantage as it developed the television internally by procuring the liquid crystal panel and the plasma panel. Fig. 2 shows the market

share of Sony, and how the company gained market share for both the LCD TV and PDP TV. Next, an analysis was

conducted to reveal how Sony developed these four product features without owning the panel device technology.

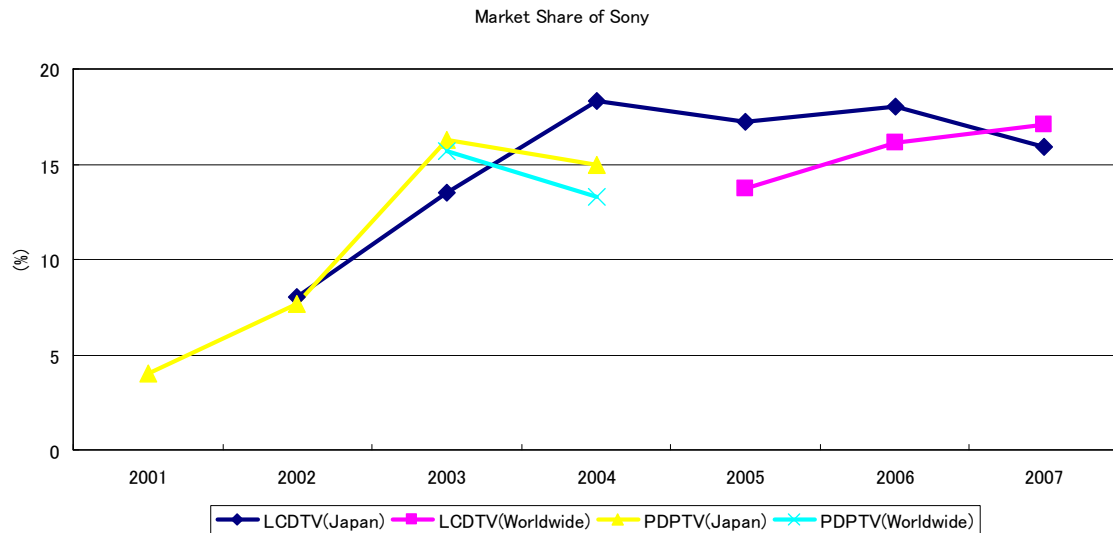

Fig. 2 The market share of Sony

C. Flexibility in Panel Device Procurement and TV Development

It was said that the panel would account for about 60–70% of the cost of materials for the plasma and the LCD TV, making the panel's quality a major factor for controlling the TV's cost competitiveness.

Sony procured plasma panels from Pioneer, Fujitsu-Hitachi, NEC, and Samsung SDI (Fig. 3), based in part on cost. The size to which the plasma panel could be cut changed with each generation of the technology, and the efficiency in each generation was different. Sony's policy was to purchase the panel from any firm, according to the specifications, and selected high quality panels at a cost that was good but higher than the average cost of earlier models from Sharp, LG Philips LCD, AUO, CMO, and Samsung.

Another selection criterion was the panel's characteristics. Since each panel manufacturer's technology had different strengths, Sony could easily achieve the desired product specification by procuring the panel closest to it from its manufacturer. Developing products of various types became possible by choosing panels of various sizes and other characteristics from two or more manufacturers.

In addition to buying a ready-made panel, Sony would also modify it to create an original panel. For instance, by improving only the driver of the plasma panel, but not the sound or the step expression, only Sony's variation of the product was enhanced. The advantages to procuring both plasma and LCD panels were to develop both kinds of televisions, so that Sony could then respond to the technology and market changes by procuring the necessary panels externally. However, buying only externally developed panels was not necessarily a positive strategy. For example, when the flat panel TV market expanded rapidly, the demand quickly began to exceed supply, and Sony lost reliable LCD panel makers from 2004 through to the first half of 2005

because they could not control the amount of the panels available externally, and they could not produce them in-house.

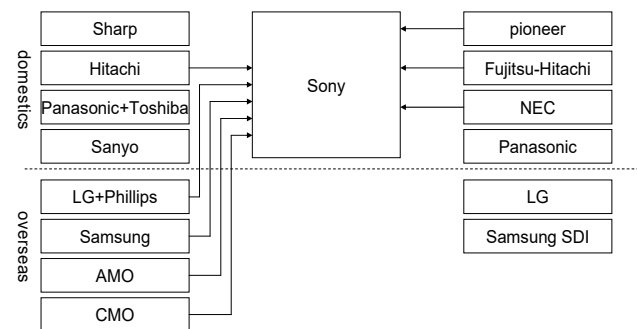

Fig. 3 Sony procurement method of panel development (~2005)

Sony had expected a substantial change in balance to the demand-and-supply for flat panel TVs to take several years due to the rapid market expansion. In order to adapt to the situation, Sony converted to the policy of LCD panel production, but since the company had developed neither knowledge nor the skills necessary for LCD panel manufacturing in-house, and the load of capital investment was heavy, they found it difficult to establish the LCD production line. Therefore, Sony was left with realistic choices such as to partner with, invest in, or purchase an existing LCD panel manufacturer. Sony negotiated concurrently with two or more LCD panel manufacturers and chose the established path of joint manufacturing (S-LCD) with Samsung. The basic technologies in the LCD panel of S-LCD were all Samsung's technologies, and it cost about \$2 billion for Sony to secure the stability, quality, and low-cost of the panel supply. S-LCD manufacturing and shipping operations began in April 2005.

Sony decided to withdraw from the plasma TV market in 2005 after starting the S-LCD Corporation. Before that, the LCD TV and the plasma TV were divided at the boundary of the 37-inch panel. Therefore, with the capability to develop two or more technological systems, Sony could manufacture both big and small screen TVs, and thus target a wider consumer market.

Sony took good advantage of mass production by having cooperated in S-LCD with Samsung, which was one of the world's largest LCD panel manufacturers. On one hand, the higher quantity of panels it produced with the consolidated equipment, the lower the cost of a panel became, and since S-LCD accounted for about 30–40% of the global market share, it enjoyed high economies of scale, which contributed to lowering the cost of the product. On the other hand, the post-processing in S-LCD enabled differentiation by adding Sony's innovations to Samsung's. The image quality was branded "Picture by Sony," and the "Sony panel" was developed. Many large-scale, medium, and thin panels were developed.

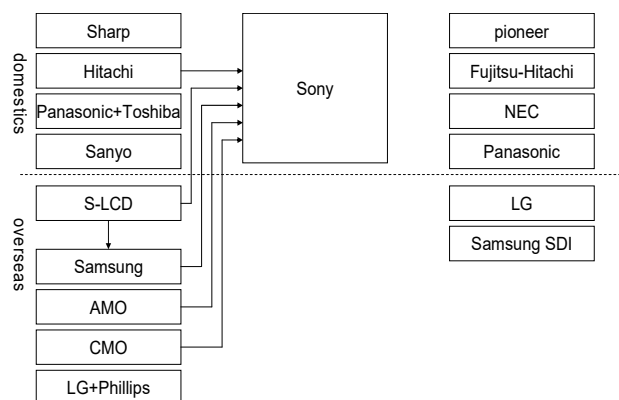

Fig. 4 Sony procurement approach of panel development (2005~)

In addition to S-LCD, Sony has also been procuring panels from Taiwanese panel manufacturers such as AUO, CMO, and CPT, which depended upon the features offered by each manufacturer's panel. Sony's strategy enables them to select low-cost panels while meeting changes in market demand without having a large shortfall resulting in any given product based upon the panel supply from S-LCD alone. Typically, Taiwanese manufactured small panels are cheaper than S-LCD's, so Sony buys Taiwanese manufacturers' small panels for the cost-based competitive advantage, and medium and large panels from S-LCD. Sony's unique panel is made in cooperation with a Taiwanese manufacturer, who provides the specifications of the cell from which Sony then develops the T-Controller, resulting in Sony's unique panel. Thus, Sony's strategy achieves low-cost panel production in two ways: mass production by sharing the initial process of panel production in S-LCD with Samsung and procuring low-cost panels from several Taiwanese manufacturers. The Sony strategy also provides flexibility and diversity of products through two tactics: S-LCD's separate post-processing to create Sony

panels that are different from Samsung's, and procuring their newest large and medium panels from S-LCD while buying small panels from Taiwanese manufacturers. Fig. 4 shows Sony's panel procurement approach since founding S-LCD.

D. Product Development with Different Competing Factors

Sony competes on other product differentiation factors in addition to panel size and performance. It has developed high quality, innovative designs for flat panel TVs, such as the floating design, in which the bezel around the screen appears transparent, giving the illusion of the display floating in an art frame of a consistent width. This innovation creates a sharp finish that takes advantage of the luster of the metal and glass flakes to make the color change slightly.

Sony focuses on developing televisions with innovative and advanced designs in order to keep ahead of other firms, even though many firms in the flat panel TV market are now also attempting innovative designs. In Sony, advanced design has become a high priority in product development.

	CRT TV	PDP TV	LCD TV
enlargement	△	◎	×
thin and light	×	◎	◎
high-definition images	◎	○	△
wide viewing angle	○	○	△
low power consumption	△	×	△

◎: Best, ○: Better, △: Good, ×: Not Good

Fig. 5 Comparison of TV technological systems (around 2000)

Since it was difficult to improve the display quality beyond those of rival firms without owning the panel device technology, Sony concentrated on design. Initially, Sony's design was inferior, and it could not claim that the basic performance of the plasma and LCD TV image quality was better than that of the tube television (Fig. 5). Therefore, firms with the panel device technology worked on improving the performance of the panel. Pioneer's plasma panel was noted for its high technology, and panel performance became the differentiator of each firm's image quality. This situation left Sony, which purchased panels from the technology owners, to differentiate its products on design elements other than the panel.

Sony tried to match their flat panel TV's features to changes in consumers' criteria. Consumers buy plasma and LCD TVs on criteria other than thinness, low price, or even the image quality, as all manufacturers' displays had become good enough to satisfy them. Therefore, as the importance of other factors increased, Sony paid increasing attention to their design.

III. CASE STUDY 2: CASIO'S CASE

A. The Outline of Digital Camera Industry

Prior to 1995, the digital camera was mainly used by professionals, and it had more than 100 mega pixels CCD and was highly efficient. However, it was too expensive for general consumer to buy. On the other hand, the "QV-10" had 25 mega pixel CCD, a single focus lens, a 1.8-inch liquid crystal color display on the back and a low price of about 65,000 yen (approximately US\$ 643 at the current exchange rate). It attached greater importance to image quality than to handiness with cheap prices. That is, the concept of "QV-10" was that of a "wearable camera".

Fig. 6 shows the transition of the market share of each entry firm in the digital camera market. Casio recorded about 46% of the market share with the "QV-10" in 1996. On the other hand, the firms that had developed film cameras, such as Olympus, Fuji Film and Canon, in addition, Sony, the firm which developed a video camera, introduced one product after another on the market and immediately took a share of the market. Therefore, Casio's market share decreased rapidly.

Competition on the image sensor and the optical zoom is one of reasons behind the fall in the market share of Casio. Most film camera makers and video camera makers recognized the digital camera market potentials through the "QV-10" success, and decided the entrance to the digital camera market. In order that those firms attain differentiation to the "QV-10", attention

was paid to the formation of many pixels of an image sensor and the large magnification of the optical zoom. The first megapixel machine, the "DS-300" was released to the market by Fuji Film in 1997, and the "DMC-FZ1" which had 12 times optical zoom was released to the market in 2002 by Matsushita Electric. These entry firms produced a video camera bearing the image sensor technology and the film camera carrying the advanced optical system technology. As typical firms, there are Matsushita Electric, Sony, and Olympus, Canon and Fuji Film. These firms have accumulated both or either image sensor technology and or optical system technology from digital camera industrial entry or before. Whereas, Casio has developed several electronics products, a calculator, a clock and an watch and TVs, and it has accumulated the high-density mounting technology and LCD technology, but it had not had the fundamental technology.

B. The Feature of "EX-S1"

Casio introduced "EX-S1" to the market in May, 2002. This model was success on the market. And so, Casio's market share was going up to more than 10% by sale of Exilim.

"EX-S1" equipped 1.34 mega pixel CCD and the single focus lens which be without the optical zoom and auto focus, and a 1.6-inch LCD display. The body thickness was 11.3 mm, and body weight was 85g. Just after it switches on, camera would be activated within about 1 second. The release time lag was about 0.01 second and the seriography interval time was about 0.6 second.

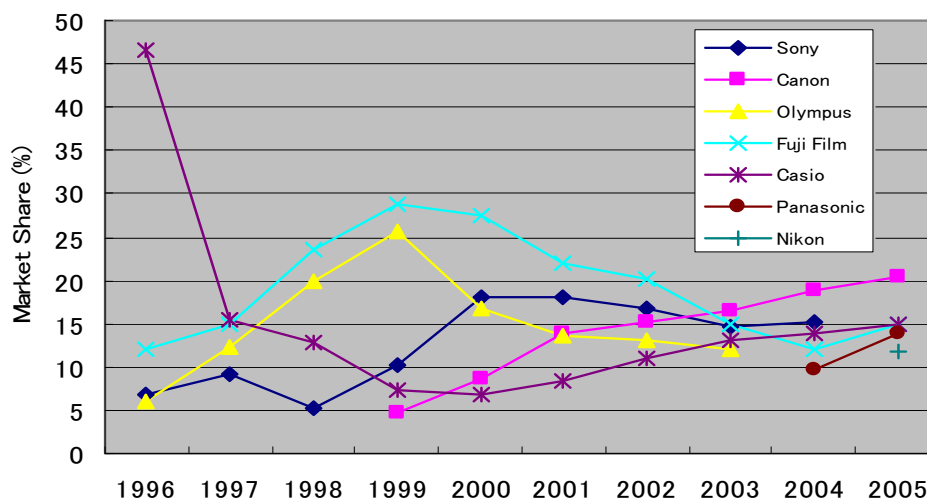

Fig. 6 Market share in the digital camera industry in Japan

The main competition dimension in digital camera industry was the high-performance of the image sensor and large magnification of a zoom lens in 2002. Firms put the megapixel machine on the market in 1998. Further, digital cameras with 3 mega-pixel CCD and 3X optical zoom were put on the market in 2000. Thus, because most digital camera had many pixels of an image sensor and large magnification of optical zoom, it could see that the digital camera's concept around 2000 was recognized as an alternate product of a film camera by each

firm. Generally speaking, about 3 mega pixel CCDs for the L size printing, and equipping the optical zoom was standard in the film camera. Therefore, to catch up with the photograph function level of a film camera, most entry firms tried to equip the high-performance image sensor and large magnification optical zoom in order to enable photography of the high definition photograph.

When comparing the standard digital camera in 2002 with "EX-S1", the product features are completely different to each

other. The former digital camera had the price range from 20,000 to 50,000 yen, and high performance photograph function, such as carrying about 3 to 5 mega pixel CCD and 3 to 5 times optical zoom. Whereas, "EX-S1" was sold by more than 30,000 yen, and pursued thin and light body, and quick operation. Therefore, while "EX-S1" was the same price range as the existing digital camera, it strengthened portability and quick reaction. On the other hand, "EX-S1"'s photograph function was reduced, such as 1.3 mega pixel CCD and a pan focus lens.

C. The Development Process of "EX-S1"

The reason why Casio tried to develop "EX-S1" was a bad condition of "QV" series. After introducing "QV-10" to the market in 1995, the formation of many pixels of an image sensor and large magnification of optical zoom break out in order to substitute still camera industry for a film camera. Olympus and Fuji Film led this competition.

Casio also followed this trend and it has introduced to the market. There were the first megapixel machine "QV-5000SX" and the first optical zoom loading machine "QV-7000SX" in 1998, and "QV-4000" with four million-pixel CCD and 3 times optical zoom in 2001. However, Casio has few sale models as compared with the other firms and has been behind the improvement in CCD pixel. As a result, Casio's market share in the digital camera market of fell to 6.9% in 2000.

Even as Casio has not own image sensor technology nor optical system technology but competed by CCD pixel and optical zoom, it thought it was hard to make the difference in the aspect of CCD and optical zoom. "QV section" personnel had been reduced, therefore, they wanted to continue its project, in other words a sense of crisis, had been increasing.

Casio founded "Internet Development Center" in April, 2000. Mr. Tadashi Takasu who has worked in the digital camera division for several years and about 30 persons transferred to it from the "QV section." "Internet Development Center" aimed to create new business related with internet business. However, since Mr. Jin Nakayama who was the core member of digital camera development of Casio and Mr. Susumu Takashima played a role of department manager, it comes to aim at digital camera development again. Mr. Takasu thought it wasteful to withdraw from a digital camera and Internet Development Center had become digital camera's *Yami-ken* (the hidden project). As many members at "Internet Development Center" have touched on digital camera development since "QV-10", they went back to "QV-10" which was the starting point of the digital camera [4]. "QV-10" could always take a photo whenever and wherever and could be created a different camera from a film camera. And "EX-S1" would shoot for unique usage of digital camera.

When Casio started to develop "EX-S1", it held neither image sensor technology nor optical system technology, however if it competed with the other firms with the same dimension of them, Casio thought that it could not show its strength. Instead, Casio considered that it should pulled out digital camera's user-friendliness and would provide a

customer with new fun. Moreover, when the development departments started, there were many engineers of a digital camera division and Mr. Takashima pointed to the component technology development for making product slim down [4].

The device maker suggested that Casio could develop the card size digital camera in the year-end party at the end of 2000. Casio promised to develop the digital camera of card size. In this way, the slimming down became clear.

In product selection meeting of Casio in April 2001, President Kazuo Kashio permitted a thin digital camera development. To realize a thin body size, various components were developed. In these processes, the high density mounting technology, LSI design technology, and liquid crystal display technology which have been accumulated under several product developments, such as a calculator, a watch and an electronic dictionary, were utilized.

First, Casio started to design the lens module from 2000. In order for a case to make thin and weight, the miniaturization of a lens module is indispensable, and it was important to have the lens of "EX-S1" thinly lighter than high-definition photography performance in lens development. All after, optical zoom, auto focus, and a macro photograph function were omitted. Especially the bottleneck of a thin weight of its case was auto focus because it needs a motor, a gear and a mass battery. Therefore, auto focus was not equipped but pan-focus is introduced. In addition, the incidence angle of light became large by bringing a convex lens to the head of lens composition and the invert Tessa system lens which can slim a lens unit down was installed. And it became possible by carrying a single focus lens, to make a main part thin lightly to physically shorten start-up time and a release time lag. Moreover, CCD combined with a lens was miniaturized. However, as result of the miniaturization of CCD, the area of a euphotic part becomes small and it induces degradation of sensitivity and dynamic range. Then, by the close connection with the CCD maker, CCD was equipped with the on-chip micro lens to lead light to a photo-diode efficiently.

If Casio equipped 3 mega pixels CCD, a high noise and a low dynamic range would become large. Therefore, 3 to 4 mega pixels was in use those days, and while 3 mega pixels or more are needed for customer satisfaction, Casio made a decision "EX-S1" equipped 1.3 mega pixels CCD in order to drop a pixel greatly and to enlarge the acceptance surface product per pixel. In addition, Casio cooperated with a CCD maker and developed the HCLi technology to make body slim down. Before, the CCD chip and the lens were separately delivered from the different device makers and were combined by the set maker side. So that, as for the thickness, about 17~18 mm was common. In "EX-S1" development, Casio could make it the module, called HCLi, which unified CCD and lens, and was able to do it thinly to 8.8 mm with a device maker's cooperation.

As a case was miniaturized, LSI design technology was used and one module board was made to accumulate CPU, ASIC, SDRAM and a flash memory which were four main LSI. This was called Multi Chip Module, MCM, which was designed in Casio and manufactured in Hitachi. By concentrating four LSI

on one chip, it made surface area reduce to 70 percent and power and noise lower, if compared with the existing parts. Moreover, a shutter interval can be shortened about 1 second. In addition, software was also improved to realize the quick operativity, such as interval shooting in about 0.6 second and release time lag in 0.01 second.

What is more, digital interface TFT liquid crystal was installed for the first time for the digital camera. Casio has been manufacturing the small and middle size liquid crystal for several products since 1973, and has been accumulating its technology. To make the digital camera, an analog peripheral circuitry becomes unnecessary because a digital signal can be directly inputted for a digital image from LSI unlike the conventional liquid crystal display monitor which changed and inputted into the NTSC signal. According to [5], since external parts, such as liquid crystal interface IC and a crystal oscillator, were omitted, as compared with the existing liquid crystal circuit board, its surface area was able to be decreased by 13%.

Since product development began in the organization whose people had attended to digital camera development, the component-engineering development for slimming down, the product development which started for the new form of the digital camera obtained an idea -card size digital camera- from firm's outside. And component engineerings, such as HCLi, MCM, and a digital interface liquid crystal, were developed, and Casio pursued thin and miniaturization. In addition, quick reaction of digital camera was made to improve through shortening of operation time mechanically and improving its software. To the contrary, taking high resolution picture function was reduced, and the concept "the wearable camera" was formed gradually in its product development. In this way, "EX-S1" which equipped 1.3 mega pixel CCD with pan focus lens was excellent in portability by 11.3 mm and 85g, and worked with quick operativity.

IV. CASE STUDY 3: NINTENDO'S CASE

In this section, we examine the 3cases of Sony, Casio and Nintendo, as a firm without fundamental technology. The data for this case study comes from interview with the firm without fundamental technology, several publications and announcements from other firms and device makers.

A. Fundamental Technology in the Game Machine Industry

The CPU installed in "family computers" was a customized MOS technology 6502. The CPU and GPU semiconductor technology installed in a game machine supported the functions necessary to operate the game. The performance of a game machine is determined by the information processing and the drawing ability of the CPU and GPU.

Each game machine manufacturer works on the core task of developing the game machine beyond the basic family computer to improve the drawing ability by installing the most efficient CPU and GPU, in order to achieve detailed graphics. The images produced by game machines in the 1980s lacked reality and were rougher than television images. Recognizing that the performance improvement of the CPU and GPU was

important in game machines, the game machine manufacturers adapted the personal computer CPU and GPU for more vivid game imagery in their new game machines. Because Nintendo does not possess CPU and GPU semiconductor technology, it manufactures neither the CPU nor GPU for its Wii game machines but procures customized CPUs and GPUs from external semiconductor firms.

This case study examines Nintendo's advantages without fundamental technology through the Wii development case by analyzing its product development process.

B. Nintendo Game Machines before Development of Wii

This section analyzes the product development of Nintendo's Wii (Fig. 7).



Fig. 7 Wii

Nintendo introduced the Nintendo Entertainment System (equipped with an 8-bit CPU) in the market in July 1983 (Fig. 8). As its product name implied, the Nintendo Entertainment System was developed for the entire family to play, and was different from earlier computer games. It aimed to be easy to operate and enjoy, and was developed under the concept "play control". This concept did not compromise the graphics function of the game. It used an 8-bit CPU with the same 6502 processor as that installed in the Apple II in order to provide performance equal to that of an arcade game machine. In contrast, a low-cost IC semiconductor chip was purchased from Ricoh, and requested \$20 or less the unit price did. Thus, the Nintendo Entertainment System could sell at a lower price while having a performance equal to that of competitors' products. It sold 1.4 million units in one year, and the game machine industry was established and has since expanded. Eventually, it accounted for 90.9% of the worldwide sales of 8-bit machines.

After the first half of the 1980s, other companies also introduced the 8-bit, 16-bit, and 32-bit CPUs in the market. The focus of gaming hardware development was on faster processing performance by the CPU and GPU to achieve the highest performance and highest resolution motion. Nintendo introduced the Nintendo Super Entertainment System in the market in November 1990, NINTENDO 64 in June 1996, and the GameCube in September 2001.

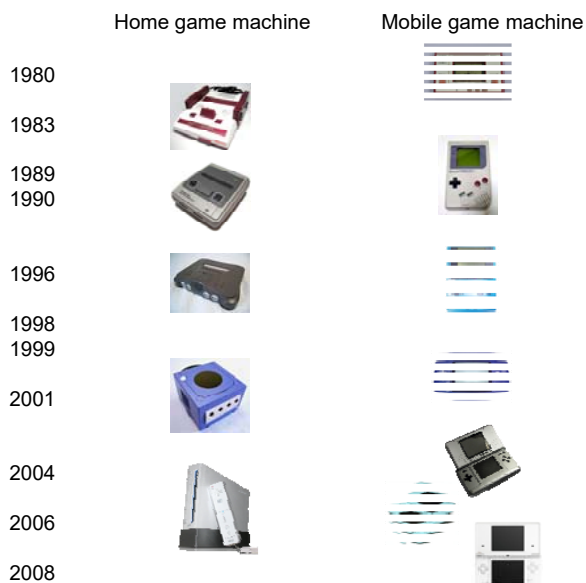

Fig. 8 Nintendo Game Machines

× 274mm (length × side × depth), and it weighed approximately 4.4–5 kgs, making it larger and heavier than the Xbox 360.

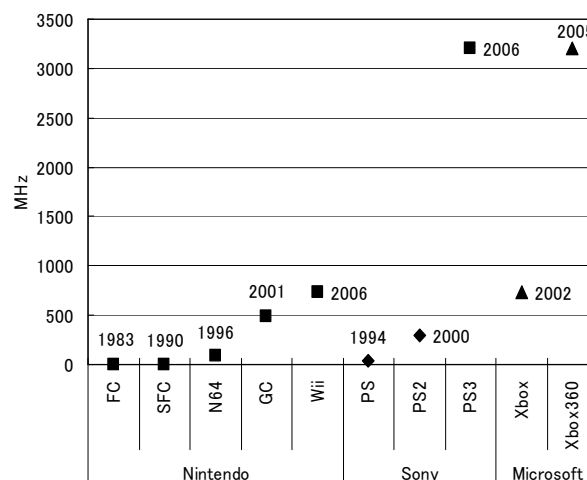

Fig. 9 Speeding up of CPU

The 1990 Nintendo Super Entertainment System greatly improved the image processing performance with a 16-bit CPU. The NINTENDO 64 with a 64-bit CPU entered the market in June 1996. It had the VR4300 customized 64-bit CPU and Reality Co-Processor with a 32-bit RISC R3000 in its GPU. The GameCube followed NINTENDO 64 in September 2001 with an IBM Power PC Gekko 485MHz CPU and the Flipper GPU by ArtX Co.

As mentioned above, the product development of the Nintendo Super Entertainment System and GameCube consistently focused on high-resolution game image quality. The image processing performance and the drawing ability were improved by speeding up the CPU and GPU (Fig. 9). In the background, the improvement of the image processing performance may have been driven by 3-dimensional CG rendered graphics, which was similar to that of their competitors.

C Rival Game Machines: Microsoft XBOX 360 and Sony PlayStation 3

Microsoft introduced the Xbox 360 in the market in 2005, with a CPU clock frequency of 3.2GHz and a custom graphic processor Xenos 500MHz in its GPU. That equipment had operation processing performance equal to a desktop personal computer at that time. The size of the main body was 309 × 258 × 83mm (length × side × depth) and it was heavy, weighing about 3.5kg.

Sony introduced the PlayStation 3 in the market in November 2006 that used a Cell Broadband Engine CPU with a clock frequency of 3.2GHz and a RSX (Reality Synthesizer) GPU with a clock frequency of 550MHz. It had an arithmetic capacity equal to that of the personal computer with the CPU that Sony had developed jointly with Toshiba and IBM. Its GPU was developed based on the GeForce7800 GTX for the NVIDIA personal computer. The size of the body was 325 × 98

As mentioned above, the Xbox 360 and PlayStation 3 were game machines that advanced the evolution of CPU and GPU efficiency, consistent with the technology road map. The development of the next-generation game machine usually begins immediately after the previous generation enters the market, assuming that an existing technology is built upon in successive generations and development goals set consistent with the technology road map.

D. Outline and Competitive Advantage of the Wii

The Wii is a game machine that Nintendo introduced in the market in December 2006. It belongs to the same generation as the Xbox 360 and PlayStation 3, a rival model, and a successor to the GameCube. However, the Wii, Xbox 360, PlayStation 3, and GameCube have a marked difference. The Wii uses neither a high-performance CPU nor GPU compared with the Xbox 360 and PlayStation 3. The Wii's CPU has a clock frequency of about 700MHz, called "Broadway," which was jointly developed with IBM. Its GPU, called "Hollywood," was developed in cooperation with ATI, which developed the GameCube GPU.

Nintendo developed the Wii as a game machine with features different from existing products under the new concept of a "game machine for the entire family to play together." The features enabling this concept are a joystick and a small, high-quality, and white wireless remote controller.

The Wii remote controller uses a joystick that enables intuitive operation, moving up and down, and right and left. It provides a very simple and understandable user interface, perfect for new users. It also has the smallest and thinnest body among the Nintendo game machines, at 44 × 157 × 215.4mm (length × side × depth). It was designed specifically to be placed by the television, which occupies a prominent place in people's living rooms. Therefore, the Wii has a simple shape that can be set up inconspicuously on its stand, in harmony with other television peripherals.

With its new concept and features, the Wii successfully concluded Nintendo's expansion into its targeted game market population, the entire family. As a result, Wii sales exceeded five million units in two months of one year, and its foreign sales totaled about 15 million. The Wii has a market share of 63% in the game machine market in Japan, whereas PlayStation 3 has 20%, PlayStation 2 has 13%, and Xbox 360 has 4%, respectively. Sales of Nintendo in 2008 totaled \$16.7 billion.

V. THE ADVANTAGES OF A FIRM WITHOUT THE FUNDAMENTAL TECHNOLOGY

A. *Two Advantages of a Firm without Fundamental Technology*

There are two advantages for firms that lack fundamental technology. First, those firms have the flexibility to respond quickly to environmental changes at low costs—the economic advantage. Second, such a firm can demonstrate its own strengths without certain systemic organizational restrictions – the organizational advantage. This section clarifies the mechanisms of the strengths of firms without fundamental technology by focusing on these advantages.

The economic advantage on the financial side of the firm brings advantages from building relationships with external sources in order to reduce the firm's costs. In addition to cost reduction, such firms enjoy an organizational advantage in decision making and organizational behavior.

B. *Sony's Economic Advantage*

Sony procured the panel device from external sources because it did not own the panel device technology for plasma and LCD flat panel TVs. In so doing, Sony could select the most appropriate panel for product specification among several manufacturers at the lowest cost through competitive bidding for their business.

In the plasma panel market, each manufacturer had a different price within each size of the panel. Sony compared the panel costs of the plasma manufacturers to develop a low-cost TV by procuring a relatively cheaper panel. Among LCD panel manufacturers' comparative costs, Sony bought the panel with the highest cost–performance through competitive bidding.

To develop products with feature variations, Sony made the best use of the size and the features of the panels of each manufacturer while choosing the lowest cost panel with the specified features. It procured LCD panels from two or more manufacturers, such as LG Philips, AUO, CMO, and Samsung. Sony expanded its LCD TV line by procuring different screen size panels from different manufacturers.

In addition to external procurement, Sony invested in a joint factory with Samsung in 2005 from which it also obtained LCD panels. Sony achieved economies of scale by sharing the first part of the panel manufacturing process in the S-LCD factory in cooperation with Samsung, which greatly reduced the cost of the panels. With each firm performing separate post-processing, Sony's final LCD panels could be different from Samsung's.

Sony developed TVs with two technological systems by procuring the plasma LCD panels from several manufacturers. Both technological systems were procured only after the survival domain was determined by the screen size, the TV was then developed and a wide consumer market was targeted. Thus, technological flexibility becomes an economic advantage for avoiding market uncertainty. Sony achieves even greater flexibility by quickly procuring panels with the newest technology at the lowest cost by switching manufacturers and installing new functions in the panel based on the new panel's additional capabilities.

Sony also changed their procurement method. At first, they procured the plasma LCD panels only from external manufacturers. The investment with Samsung in the joint S-LCD factory allowed Sony to procure panels manufactured there, as well. Thus, Sony gained the greatest possible economic advantage from flexibility in purchasing the lowest cost panel with the best technology in any screen size to meet market demands through concurrent external and S-LCD procurement options.

Technological developments and market trends drove Sony to stop purchasing plasma panels, and to concentrate on the development of LCD TV. Other factors in this decision were that Sony had neither the internal staff nor equipment for plasma panel production and its sunk cost was low. Thus, we see the full range of economic advantages for a firm without the center technology—lower cost and higher flexibility in critical elements of technology selection and design enhancements, which allows them to meet rapidly changing market demands.

C. *Casio's Economic Advantage*

When the lens was procured, Casio was able to selected two methods in the EX-S1 development because Casio did not have an advanced optics system technology. Through joint development, Casio designed the single focus lens in-house and consigned the manufacturing to outside sources. Another method is purchasing the optical zoom lens with a difficult design as a lens module from outside sources. Casio procured this module from several lens manufacturers in the procurement of the optical zoom lens. In addition, Casio switched these procurement methods and device makers within one year.

Casio also selected CCD because it did not have the image sensor technology. It procured the module from joint development efforts. Casio had already put the model equipped with between two to four megapixel CCDs on the market before HCLi was developed. Those CCDs had been procured as a module from outside sources. Casio not only developed HCLi in cooperation with the CCD manufacturer, but also procured two to four megapixel CCDs when it switched its procurement method. The CCD module with its different size and number of pixels was procured for the six megapixel digital camera to the 12 megapixel digital camera before and after the EX-Z1000. Casio switched device makers and could equip the EX-Z1000 with the latest ten megapixel CCD.

D. Nintendo's Economic Advantage

Nintendo obtained its CPUs and GPUs externally because it lacked these technologies. The Wii's Broadway CPU was jointly developed with IBM based on the Power PC technology and manufactured at the IBM factory in East Fishkill, NY. The Hollywood GPU was jointly developed with ArtX.

By jointly developing their CPU and GPU with firms having powerful technologies, Nintendo could enjoy the advantage of their partner firms' expertise. Nintendo chose to partner with IBM and ATI rather than developing their CPU and GPU in-house because those firms had the technology and know-how that Nintendo required. Another advantage is the power to select the optimal development partner from among a wide selection of manufacturers.

A firm without fundamental technology is also free to change its development partner, depending on the evolving technology it needs and that technology's best manufacturer. The family computer used Ricoh's CPU, as did the Nintendo Super Entertainment System. The NINTENDO 64 changed to the customized NEC VR4300 CPU, based on the MIPS R4300. The GameCube switched to IBM's Gekko CPU based on IBM's Power PC. The Wii uses IBM's Broadway which was originally developed for PowerPC.

For its GPUs, Nintendo first used Ricoh's GPU in its family computer and the Nintendo Super Entertainment System. In the NINTENDO 64, it switched to a RISC type microprocessor, the R3000 developed by MIPS Technologies. For the GameCube, Nintendo again switched, this time to the ArtX Flipper, and then to ATI's Hollywood for the Wii.

As mentioned above, with each new game machine, Nintendo has appropriately changed its CPU and GPU providers. Such "ease of switching" enables low-cost, revocable choices of development partners when better options appear.

E. Sony's Organizational Advantage

Since Sony does not own the panel device technology, it is difficult to differentiate its products on the performance of the panel. This limitation increases the intensity of a firm's search for other differentiators [16] and improves the likelihood of its developing distinctive features.

In Sony's search for product differentiators, it chose the design of features other than panel performance, which is determined by the internal technology. Previously, Sony had accumulated knowledge about internal product design, but in flat panel TV development, the designer is registered in a separate design center section.

In order to differentiate LCD TVs with features unique to Sony, they had to change the prioritization of product features. However, such a game-changing decision does not happen automatically, but requires the impetus of a certain level of organizational tension. Sony's success in the CRT TV market generated high expectations for the flat panel TV business that followed it. These expectations grew as the LCD screen became the center of digital AV equipment, and was thus considered crucial for digital consumer electronics producers.

In the face of strong competition among manufacturers, Sony's flat panel TV product development had a high target.

The apparent conflict between Sony's high production target and its lack of panel device technology created the necessary organizational tension to trigger innovative thought and decision-making. As the product planner thinks that he should make some kind of change and carries the sense of crisis, he engages others to share the sense of crisis as much as possible and so innovative product designs were developed. Thus, Sony generated the psychological energy that drove them to adopt the strategy of focusing their flat panel TV differentiation on product design.

F. Casio's Organizational Advantage

Casio experienced difficulties when competing with other firms. It did not persist in developing and manufacturing its camera based on the concept of a replacement for the film camera by including a standard function, such as the optical zoom and AF. The LSI design technology and the LCD technology that Casio had been accumulating in another business division were exploited. Casio developed MCM and a large-scale digital interface LCD, which differentiated its products from those of competitors. Moreover, a flat and compact design was achieved in the development of the EX-Z1000.

G. Nintendo's Organizational Advantage

Without the semiconductor CPU and GPU technology in-house, Nintendo cannot differentiate its game machines based on CPU and GPU performance. However, because differentiation is necessary for competitive advantage, Nintendo differentiates in the other characteristics of its game machines.

After 1994, Nintendo lost its top position in the game machine industry as its sales and market share numbers flattened. President Iwata pointed out the cause: their current game machine had become too complex, which discouraged consumers. In response to the consumer demand for an easier system, Nintendo developed the Wii, targeting those consumers who had either never played computer games or had stopped playing.

The key concept of the Wii is that it is for the "entire family" and "everyone can play." Its interface features intuitive operations so that people consider the Wii as a game system that the entire family can relate to, with a user-friendly interface and high performance. The Wii controller demonstrates these concepts in its comfort, user-friendliness, and simplicity so that everyone in the family can use it.

As mentioned above, when the Wii was developed, Nintendo did not differentiate based on CPU and GPU performance but on the machine's other characteristics. In order for the Wii to stand out in its market, Nintendo had to focus on features under its own control rather than machine specifications. Motivated to explore new concepts that would demonstrate its originality in other dimensions, such as the user interface, Nintendo hit upon the new concept, "a game that everyone in the family can

play.” However, exploring different values as a competitive factor does not happen naturally, and Nintendo had already been differentiating its products with increasingly high-performance CPUs and GPUs in the game machines preceding the Wii. Nintendo could respond effectively to the organizational sense of crisis that spurred the development of a different game machine with a unique market differentiator by following the industry’s technology road map. That strong organizational sense of crisis began with the GameCube’s decrease in competitive position. Several Nintendo managers felt this sense of crisis first, and then it expanded throughout the entire firm.

The breakthrough concept enabled Nintendo to compete effectively even without having to differentiate in its semiconductor technology, but that radical change to a completely new competitive factor resulted from a crisis that drove it to create new product with a different concept.

VI. CONCLUSION

In this study, it is focused to two advantages—economic and organizational—based on the analysis of Sony’s case as it sought the advantages held by firms without the center technology.

The economic advantage results from the flexibility obtained without the center technology, which had been identified by the early research. This study then found that wide selection in procurement means that such firms can choose the highest-performance center technology product from several options and switch easily among manufacturers for low-cost and flexible response to both technical and market demand changes in a highly competitive environment.

This study also found another advantage of firms without center technology—organizational advantage. Such a firm has trouble in differentiating their products from other firms’ products due to the lack of center technology. Therefore, the firm needs to try to offer the customer new value by creating a different concept, and uses the organizational tension to spur innovative product development. A firm without center technology makes the best use of these two advantages and develops the most innovative product.

REFERENCES

- [1] Wernerfelt, B. (1984) “A Resource-Based View of the Firm,” *Strategic Management Journal*, 5, 171-180.
- [2] Barney, J. B. (1991) “Firm Resources and Sustained Competitive Advantage”, *Journal of Management*, 17, 1, 99-120.
- [3] Prahalad, C K. and G. Hamel (1990) “The Core Competence of the Corporation,” *Harvard Business Review*, 68, 3, 79-91.
- [4] Itami, H. (1987) *Mobilizing Invisible Assets*, Harvard University School Press.
- [5] McEvily, S. and B. Chakravarthy (2002) “The Persistence of Knowledge-based Advantage: An Empirical Test for Product Performance and Technological Knowledge,” *Strategic Management Journal*, 23, 4, 285-305.
- [6] Nelson, R. and S. Winter (1982) *An Evolutionary Theory of Economic Change*, Harvard Business School Press.
- [7] Rumelt, R. (1984) “Towards a Strategic Theory of the Firm,” in *Competitive Strategic Management*, R. Lumb(ed.), Prentice-Hall.
- [8] Dierickx, I. and K. Cool (1989) “Asset Stock Accumulation and Sustainability of Competitive Advantage,” *Management Science*, 35, 12, 1504-1514.

- [9] Peteraf, M. (1993) “The Cornerstones of Competitive Advantage: A Resource-Based View,” *Strategic Management Journal*, 14, 3, 179-191.
- [10] Levitt, B. and J. March (1988) “Organizational Learning,” *American Review of Sociology*, 14, pp. 319-340.
- [11] Leonard-Barton, D. (1995) *Wellsprings of knowledge: Building and Sustaining the Sources of Innovation*, Harvard Business School Press.
- [12] Ulrich, K. T. (1995) “The Role of Product Architecture in The Manufacturing Firm,” *Research Policy*, 24, 419-440.
- [13] Baldwin, C Y. and Kim B. Clark (2000) *Design Rules: The Power of Modularity*, MIT Press.
- [14] Dedrick, J., K. Kraemer, and G. Linden (2008) “Who profits from innovation in global value chain? A study of the iPod and Notebook PCs,” *Sloan Industry Studies working papers*, WP, 2008-2015.
- [15] Linden, G., K. Kraemer and J. Dedrick (2009) “Who captures value in a global innovation network? The case of Apple’s iPod,” *Communications of the Acm.* 52, 3, 140-144.
- [16] March, J and H. Simon (1958) *Organizations*, John Wiley & Sons.
- [17] Christensen, C M. (1997) *The Innovator’s Dilemma*, Harvard Business School Press.