

# Systematic Functional Analysis Methods for Design Retrieval and Documentation

L. Zehtaban, and D. Roller

**Abstract**—Apart from geometry, functionality is one of the most significant hallmarks of a product. The functionality of a product can be considered as the fundamental justification for a product existence. Therefore a functional analysis including a complete and reliable descriptor has a high potential to improve product development process in various fields especially in knowledge-based design. One of the important applications of the functional analysis and indexing is in retrieval and design reuse concept. More than 75% of design activity for a new product development contains reusing earlier and existing design know-how. Thus, analysis and categorization of product functions concluded by functional indexing, influences directly in design optimization. This paper elucidates and evaluates major classes for functional analysis by discussing their major methods. Moreover it is finalized by presenting a noble hybrid approach for functional analysis.

**Keywords**—Functional analysis, design reuse, functional indexing and representation.

## I. INTRODUCTION

REUSING the engineering know-how in cooperation with Computer Aided Design (CAD) software has improved the product design with a higher quality, less cost and short lead-time. Based on geometrical nature of CAD, this know-how is mainly focused on 3D shape along with information regarding shape representation, matching, comparison and retrieval. Consequently researches on different approaches and categorization of methods has been extensively accomplished. Disregard to text-based matching, Iyer et al. [1] has listed seven main categories of methods which decompose a 3D shape into a so-called signature including Graph-based methods, Harmonic-based methods, feature-based methods, etc. However to have a comprehensive knowledge about product, the functional analysis is required as well. Chakrabarti et al. has made an overview on function-based synthesis [2]. In this paper, we discuss and evaluate three major approaches belong to the first group including APTE, FAST and IDEF0 in addition to their comparison in Sections II. Section III describes and evaluates a taxonomy-based functional analysis. A new advanced method of functional analysis and indexing is presented in section IV. Section V concludes the paper.

F. L. Zehtaban is with the Institute of Computer Aided Design Systems, Universität Stuttgart, 70569 Stuttgart, Germany (phone: 79 711 685 88327; fax: 49 711 685 88320; e-mail: zehtaban@informatik.uni-stuttgart.de).

S. D. Roller is with the Institute of Computer Aided Design Systems, Universität Stuttgart, 70569 Stuttgart, Germany (phone: 79 711 685 88320; fax: 49 711 685 88320; e-mail: roller@informatik.uni-stuttgart.de).

## II. NEW PRODUCT DESIGN

According to Evrard et al. [3], design methods can be divided into two main categories: New Product Design (NPD) and Axiomatic Design. Axioms are used in Axiomatic design to scientifically control the design process. In contrary, NPD uses various tools to enhance creativity and innovation in design which help the designer from the very early stage of design. Fig. 1 demonstrates NPD phases and structure. Supplementary tools used by NPD, may refer to improve the managing of the mapping and interoperation between the domains or taking the user more into account during the design process. One of the major tools used by NPD regards to functional analysis and technical observation. In the next sections three methods of functional analysis including APTE, FAST and IDEF0 are briefly discussed and presented by examples.

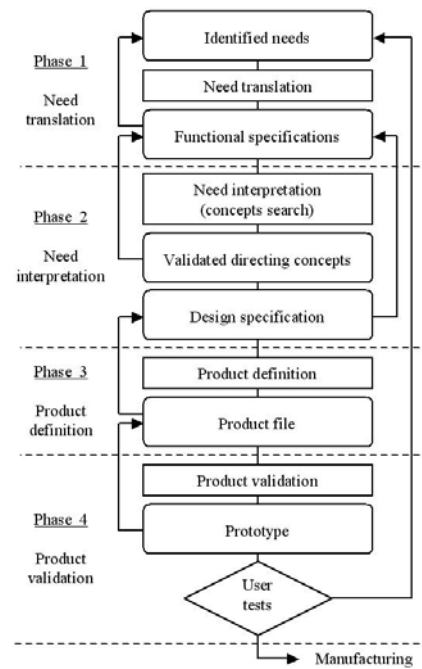

Fig. 1 Different phases and procedure in New Product Design (NPD) [4]

### A. APTE

One of the tools used by NPD is APTE method (Application aux Techniques d'Enterprise or in French: Application to business TEchniques). APTE has been created by Gilbert Barbey in 1964 and is focused on the functional analysis at the early stages of design [5], [6]. Currently, this method is deposited by APTE Company and designates a

functional analysis method in addition to value analysis to drive innovations and projects optimization [6]. APTE is applied for various applications including product design, manufacturing process, as well as organizations. APTE has been entirely presented by Bertrand de la Bretesche in the book *APTE method: value analysis, functional analysis* in French language [5]. Although this book and APTE method is widely thought in engineering and business schools in France, it is hardly possible to find a reference for the method in any other language. According to Bertrand de la Bretesche, the former CEO of APTE company, philosophy of the company has been structured as follow: "rather than do what you can with what you have, do what you need at the lowest cost" [6]. Respectively, the ultimate goal of APTE is achieving to two objectives: first increasing the product quality toward meeting the user requirements and second reducing the cost of product. Increasing quality of a product while reducing its cost is an ideal objective for any enterprise however a challenging problem for designer and manufacturer which can be incompatible. In a novel approach, APTE method has based its principle on four approaches including functional approach, systemic approach, qualitative approach and economic, interdisciplinary approach and participatory. In the first step, APTE completes the following two analyses:

- 1) Failures (gaps) and causes of the difference between optimum/desired quality and the current quality (Value Diagnosis)
- 2) Failures (gaps) and causes of these gaps between the just necessary expenses to satisfy functions and costs of the actual solution (Cost Diagnose).

Whether for the specification, design or diagnosis, APTE method distinguishes between what is "useful" and "useless" by distinguishing between the following two groups:

- 1) "just enough" group: which contributes directly affects on the purposes (functions)
- 2) "design feature" group: which depends only on solutions

APTE consists of six different algorithms to analysis different aspects of a product [6]:

- 1) Octopus Diagram: to identify the functions
- 2) La Bête A Cornes: to define the requirements
- 3) The Functional Block Diagram: to identify the design logic
- 4) The Array of Functional Analysis: to distinguish the cost of just necessary design function
- 5) The Tree of Technological Pathways: to find principles and alternatives
- 6) The list of States: to identify the functions of a process

The Octopus diagram which serves the functionality analysis of APTE method is briefly explained in the next section.

### Octopus Diagram

Octopus diagram is applied after analyzing of the costumer need where functional analysis determines the functional requirements. The first step is to investigate on the connections between the product and the external environment. According to [7] these connections are divided into two lists, as illustrated in Fig. 2:

-*Constraint Requirements (CR)*: refers to presents adoption or action of the product, in means of either the product has to be adopted with an element or it acts on an element.

-*Functional Requirements (FR)*: interaction of the product with elements of the surroundings.

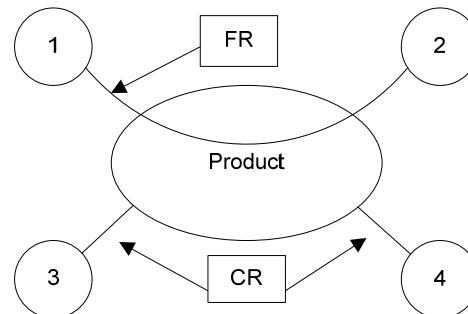

Fig. 2 FR and CR in Octopus diagram

This method defines the main functions in addition to the constraint functions to have an overview or a global view of the product. However, octopus diagram does not clarify which functions are received or generated by the main function; it merely expresses the needs of a user.

### B. Functional Analysis Systems Technique

The Functional Analysis Systems Technique (FAST) was introduced by C. W. Bytheway an engineer at Sperry Univac (Unisys) in 1960 [8], [9]. FAST diagram constitutes an essential data set enabling to have a good knowledge of a complex product. The Association of French Normalization (AFNOR) in NF EN 12973 [10] describes the FAST diagram as one of usual methods of functional analysis. FAST methodology is based on decomposition of each basic function of a product and their classification using a logic diagram. The logic diagram helps to find and approves alternatives for inventive new model to complete the function. The method has different stages [11]:

Stage 1: Brainstorm all the expected functions from costumer point of view

Stage 2: Select the overall product function

Stage 3: Apply a categorization for functions into basic and secondary

Stage 4: Arrange functions in a critical path

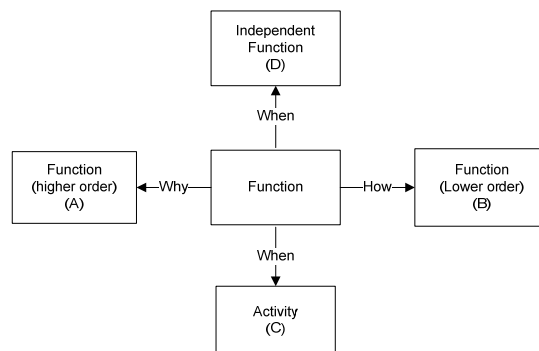

Fig. 3 Fast logical diagram [12]

The method leans on an interrogative technique with asking three questions [9], regards to Fig. 3. The following questions complete the diagram [12]:

1. HOW is (function) to be accomplished? By (B)
2. WHY is it necessary to (function)? So you can (A)
3. WHEN (function) occurs, what else happens? (C) or (D)

The responses to each mentioned question are neither exclusive nor unique. They can be singular, multiple (using AND connection) or optional (using OR connection).

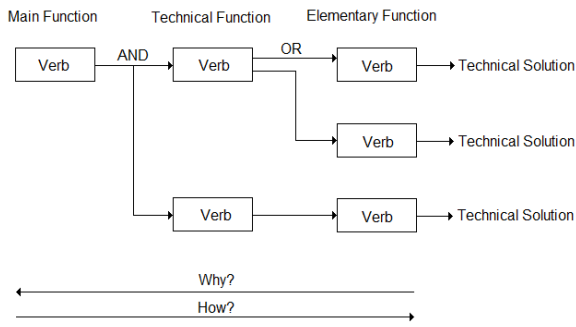

Fig. 4 Function hierarchy in FAST Diagram based on [9]

Functions in FAST are required to be described with a verb at the infinitive form. In order to enable an easy comprehension of all, this type of representation is normalized, Fig. 4.

### C. IDEF0

According to the defense acquisition of US force program [13]: "Integration Definition for Function Modeling (IDEF0) is a common modeling technique for the analysis, development, re-engineering, and integration of information systems; business processes; or software engineering analysis". IDEF0 is a modeling language including rules and techniques to standardize a graphical representation of a system or an enterprise. The target is to support systems integration; accordingly the model includes structures for system functions (activities, actions processes, and operation), functional relationships and data (information of objects) [13], [14].

During the 1970s, the U.S. Air Force Program for Integrated Computer Aided Manufacturing (ICAM) set an objective for application of computer technology systematically. The long term goal was to increase the manufacturing efficiency. Hence the ICAM program spotted better analysis and communication techniques to improve manufacturing productivity. The ICAM program designed and constructed the IDEF techniques, a series of techniques which aim to model different aspects of a system as following [13]:

- 1) IDEF0, to create a "function model". A function model is a structured representation of the functions, activities or processes within the modeled system or subject area.
- 2) IDEF1, to create "information model". An information model represents the structure and semantics of information within the modeled system or subject area.
- 3) IDEF2, to create a "dynamics model". A dynamics model represents the time-varying behavioral characteristics of the modeled system or subject area.

The IDEF0 standard, Federal Information Processing Standards Publication 183 (FIPS 183), and the IDEF1x standard (FIPS 184) are maintained by the National Institute of Standards and Technology (NIST). The original model of IDEF0 is based on Structured Analysis and Design Technique (SADT) which is a diagrammatic presentation of functions and their relationship in a system [15].

The IDEF0 is able to analyze a new system or an existing system. For the new systems, it is applied to define the requirements and specify the functions. Applying this methodology helps to improve the design and implementation of a system to fulfill the requirements as well as execution of the functions accurately. In case of an existing system, the IDEF0 method analysis the content and the mechanism of functions. Afterwards the existing system will be converted into a model with hierarchical series of diagrams, texts and cross-referenced to each other [16].

The input for functional analysis in IDEF0 is the output of requirement analysis. Functional analysis comprises of the recognition of the main function (higher-level function) and the decomposition into sub-function (lower-level function). Subsequently the requirements will be assigned to the functions. In addition, each lower-level function could be decomposed consequently [14]. The two primary modeling components are: *functions* (represented on a diagram by boxes), and *data and objects* that interrelate those functions (represented by arrows) [13].

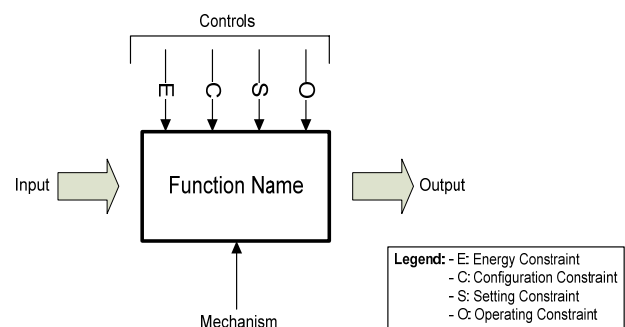

Fig. 5 Fundamentals of IDEF0 Diagram based on [13]

### D. Comparison of FAST, APTE and IDEF0 methods

In APTE method, the Octopus diagram analysis the requirements and connections of the product with external elements. The main function has an individual relation with each defined element. This method provides a general overview on the product. However, the method does not inquire how each element with the specified functionality has

to be implemented. The octopus diagram has been extracted from APTE method to identify all the possible actions from the product surroundings. This identification assists the functional analysis greatly and gives the tool a superior power. In FAST method, the main function is decomposed in technical functions and consequently into the elementary functions in a hierarchy form. Each elementary function is a solution to a technical function. This method presents the elements which compose the product. Therefore, each service function will be represented by one FAST diagram such as constraints functions to ensure the security of the user and the high-quality functioning of the product. A disadvantage for FAST refers to the fact that FAST diagram leads the user to achieve only one solution.

Both FAST and Octopus diagram are applied in value engineering [7].

IDEF0 method uses decomposition for functional analysis; though it decomposes only the main function, not the constraint functions. However, certain constraint functions are considered as a sub-function for the main function. Besides, this method indicates the restriction in implementing the function such as flows, setting and the configuration.

Among all described methods, FAST has been selected for our implementation, since its comprehensible logic significantly contributes for the documentation intention. Nevertheless all mentioned functional analysis methods are only capable of identifying a single functionality in a product, rather than providing inclusive information about all functions in a product. To fulfill this gap, the functional basis which is considered as a taxonomy-based approach for functional analysis, is applied.

### III. VOCABULARY BASED APPROACHES

The first endeavors toward functional analysis research were inspired from Value Engineering introduced by Miles in 1972. Value Engineering has highlighted the inevitability of applying explicit terminology for comprehensive concepts of design [17]. In an individual research, Rodenacker applied vocabulary-based functional analysis [18]. In 1976 Collines et al. followed this idea and listed 105 descriptions of mechanical functions [19]. Pahl and Blitz in 1984 categorized three types of flows and five types of functions using a systematic approach for the main product functional analysis [20]. In 1990 Hundal extended the work of Pahl and Blitz and listed six essential functions and assigned more specific sub-functions as well [21]. In an independent endeavor in Soviet Union, the TRIZ (Teoriya Resheniya Izobretatelskikh Zadatch) or occasionally called TIPS (Theory of Inventive Problem Solving) was invented to introduce 30 functional descriptors for explaining all mechanical designs [22]. A significant work was done in National Institute of Standards and Technology (NIST) which is considered one of the bases of the modern Functional Basis today. In 1999 Szykman et al. developed standard taxonomies of engineering functions and flows [23], [24]. Stone and Wood initiated the Functional Basis which has a complete definitions for functions as well as flows [25], [26].

Fig. 6 briefly demonstrates a comparison between the different models functional analysis accomplished by Pahl & Blitz, Hundal as well as Functional Basis and TIPS approaches.

The most recent method for functional analysis in the group of vocabulary-based methods is based on reconciliation of the NIST taxonomy and the Functional Basis. The Reconciled Functional Basis (RFB) study is the work of two teams working separately each on a method [26]:

- 1) The researchers in of National Institute of Standards and Technology (NIST) worked on hierarchical taxonomy classification focused on product representation including various knowledge forms.
- 2) The researchers who were working on the extension of Functional Basis based on the work of Pahl and Beitz. Their work was focused on the function representation and repeatable models.

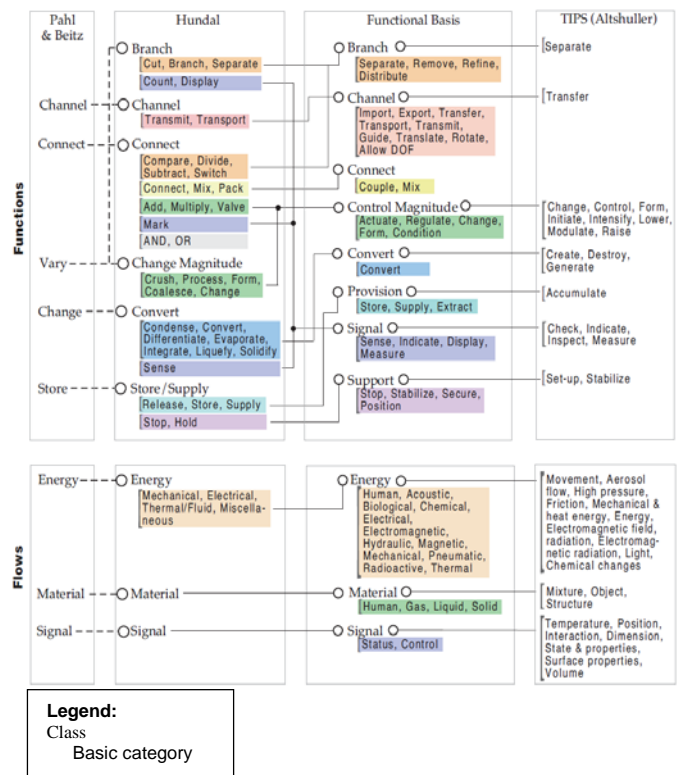

Fig. 6 Comparison of different function representations [26]

Both methods aimed to have a standard functional vocabulary. The work of each two groups resulted on creating individual functional vocabulary to represent functions and flows to be applied in a decision algorithm for similarity comparison between two functional vocabularies.

### IV. RFB FOR RETRIEVAL APPLICATION

We applied the functional analysis for similarity comparison and retrieval as well as categorization purposes. The result of functional analysis which we call functional signature saved in the database encoded in alphanumeric. The backbone of functional vocabulary in RFB consists of six categories

including: Branch, convert, channel, signal, provision, connect, support and control magnitude. Correspondently six digits are dedicated to represent functions or flows. The digits are alphanumeric digits; so they can obtain 0-9 or A-Z. To allocate a correct code to each digit, the extension of FAST method is used. Based on the FAST axiom of queries, the following questions are inquired:

- 1) What are the received flows by the main function?
- 2) What are the generated flows by the main function?
- 3) What are the functions ensured by the main product function?
- 4) Which regulations or norms the product has to respect?

Each of these questions refers to one or two digits, as follows:

- Digit 10, concerns energy flows and digit 11, concerns flows of signal and material type. These digits correspond to the received flow by the main function.

TABLE I  
 ALPHANUMERIC DIGITS FOR FUNCTIONAL ANALYSIS

Digit 14			Digit 15			
0	Channel	Import	0	Provision	Store	
1		Export	1		Store	Contain
2		Transfer	Transfer		2	Collect
3			Transport	3	Supply	
4		Transmit	4	Couple		Couple
5		Guide	Guide		5	Join
6			Translate (Slide)		6	Link
7			Rotate (Pivot)	7	Mix	
8			Allow DOF	Ball finger		8
9		Patella (hitch ball)		9	Regulate	
A		Punctual		A	Regulate	Increase
B		Annular linear		B		Decrease
C		Straight linear		C	Change	Change
D		Support plan		D		Increment
E	Sliding pivot	E		Decrement		
F	Helical slide (screw)	F		Shape		
G	Signal	Sense	G	Condition		
H		Detect	H	Stop		
I		Measure	I	Stop	Prevent	
J	Indicate	Indicate	J		Inhibit	
K		Track	K	Separate	Separate	
L	Display	L	Divide			
M	Process	M	Extract			
N	Support	Stabilize	N	Distribute		
O		Secure	O			
P		Position	P	Convert		
Q	Other	Q	Other			

- Digits 12 and 13, which are identical to digits 10 and 11 concern generated flows by the main function.

- Digits 14 and 15, concern the various classes of functions, where the number or the letter indicates the ensured function by the product.

- Digit 16 concerns the most important of constraints functions, norms and regulations, which must be respected by the product during his utilization. Table I presents the digits 14 and 15.

The system of classification by means of coding generates a referencing system for products, which enables the comparison of similarities between products.

In the next phase of our research, to implement data architecture in CAD, the eXtensible Markup Language (XML) has been selected based on the NIST research [27]. Using XML, tags are defined and implemented as well as references and mechanism. The structure based on the functional basis has been developed in order to support representation of object function models, as well as to provide a neutral format for exchange of functional-based information. The functional product information is archived, stored and shared. A user interface model has been programmed in MATLAB for data exchange and communication.

## V. CONCLUSION

This paper was a short review on various approaches for functional analysis. Beside functional analysis tools used in NPD such as APTE, FAST and IDEF0 has been discussed. In addition of the most significant development in functional analysis and a novel approach in standardization of taxonomies for description of a product functionality has been discussed. This functional definition includes flows as well as functions.

In our attempt, a new hybrid method for functional analysis has been developed which employs RFB and FAST simultaneously. This model is applicable in similarity based product retrieval for computer aided design and manufacturing. The results are satisfactory for small data base of analyzing of product functions. For this method, the functional vocabulary is converted into a signature with alphanumeric code entity. Each digit in the code presents a function or a generated flow in a product. This approach can be considered as a fundamental step for functional analysis, while implementation for focused on a specific type of product might need additional consideration. A product-based plug-in can be used for a specific group of product for the algorithm adaptation and more precise results.

## REFERENCES

- [1] N. Iyer, K. Lou, S. Jayanti, Y. Kalyanaraman and K. Ramani, "Shape Based Searching For Product Lifecycle Applications", Computer-Aided Design, vol. 37, pp. 1435-1446, 2005.
- [2] A. Chakrabarti, K. Shea, R. Stone, J. Cagan, M. Campbell, N. V. Hernandez and K. L. Wood, "Computer-Based Design Synthesis Research: An Overview", Journal of Computing and Information Science in Engineering, vol. 11, June 2011.
- [3] H. Evrard, S. Buisine and R. Duchamp, "Assessment of the Respective Benefits of 'Axiomatic Design' And 'New Products Design Method' for the Design of a Biomechanical Simulator", in Proc. ICAD2006, 4th of International Conf. on Axiomatic Design, Firenze, June 2006.
- [4] A. Aoussat, 1990, La pertinence en innovation : Nécessité d'une approche plurielle, thèse ENSAM (in French).
- [5] B. de la Bretesche, La méthode APTE : Analyse de la valeur, analyse fonctionnelle (Book Style), Pétrelle, 2000.
- [6] APTE, <http://www.methode-apte.com/>, last access on Oct. 2012.

- [7] R. Costadoat, L. Mathieu, H. Falgarone, Global Product Development, "Design Method Taking into Account Geometric Variations Management Along the Design Process", pp. 159-166, 2011.
- [8] E. D. Semmes, "Cross Cutting Structural Design for Exploration Systems", in 45th AIAA Aerospace Sciences Meeting; Reno, NV, United States NASA, Jan. 2007.
- [9] J. J. Kaufman and R. Woodhead, Simulating Innovation in Product and Services with Functional Analysis and Mapping (Book style), John Wiley & Sons, 2006.
- [10] Association of French Normalization (AFNOR): Norm NF EN 12973, AFNOR, June 2000.
- [11] K. T. Ulrich, S. D. Eppinger and A. Goyal, Product Design and Development (Book style), Irwin McGraw-Hill, 2008.
- [12] Function Analysis Systems Technique: The Basics, Save International Society, Monograph, 1999.
- [13] Draft Federal Information Processing Standards Publication 183, Announcing the Standard for Integration Definition for Function Modeling (Idef0), Dec. 1993.
- [14] Prepared by the Defense Acquisition University Press, Systems Engineering Fundamentals, supplementary text, Virginia, Jan. 2001.
- [15] D. Marca and C. McGowan, Structured Analysis and Design Technique (Book style), McGraw-Hill, 1987.
- [16] V. Grover and W. J. Kettinger, Process Think: Winning Perspectives for Business Change in the Information Age (Book style), Idea Group Publishing, 2000, p.168.
- [17] L. Miles, "Techniques of Value Analysis and Engineering (Book style)", McGraw-Hill, New York, 1961.
- [18] W. G. Rodenacker, Methodisches Konstruieren (Methodical Design, 4th edn) (Book style), Berlin/Heidelberg: Springer-Verlag, 1991 (1st edn., 1970)
- [19] J. Collins, B. Hagan and H. Bratt, "The Failure-Experience Matrix - a Useful DesignTool", Transactions of the ASME, Series B, Journal of Engineering in Industry, 98:1074-1079, 1976.
- [20] G. Pahl and W. Beitz, Engineering Design: A Systematic Approach (Book style), Design Council, London, 1984.
- [21] M. Hundal, "A Systematic Method for Developing Function Structures, Solutions and Concept Variants", in Mechanism and Machine Theory, vol. 25, pp. 243-256, 1990.
- [22] Z. Hua, J. Yang, S. Coulibaly and B. Zhang, "Integration TRIZ with problem-solving tools: a literature review from 1995 to 2006". International Journal of Business Innovation and Research 1 (1-2): 111-128., 2006.
- [23] S. Szykman, J. W. Racz and R. D. Sriram, "The Representation of Function in Computer-based Design," Proc. of the 1999 ASME Design Engineering Technical Conf., 11th International Conf. on Design Theory and Methodology, Paper No. DETC99/DTM-8742, Las Vegas, NV, September. 1999.
- [24] S. Szykman, J. Senfaute and R. D. Sriram, "The Use of XML for Describing Functions and Taxonomies in Computer-based Design," Proc. of the 1999 ASME Design Engineering Technical Conferences, 19th Computers in Engineering Conference, Paper No. DETC99/CIE-9025, Las Vegas, NV, Sep. 1999.
- [25] R. Stone and K. Wood, "Development of a Functional Basis for Design", Journal of Mechanical Design, vol. 122, no. 4, pp. 359-370, 2000.
- [26] J. Hirtz, R. B. Stone, D. A. McAdams, S. Szykman and K. L. Wood, "A Functional Basis for Engineering Design: Reconciling and Evolving Previous Efforts," The Journal of Research in Engineering Design, vol. 13, no. 2, pp. 65-82, 2002.
- [27] S. Szykman, J. Senfaute and R. D. Sriram, "The Use of XML for Describing Functions and Taxonomies in Computer-based Design", in Proc. 1999 ASME Design Engineering Technical Conferences (19th Computers in Engineering Conference), Paper No. DETC99/CIE-9025, Las Vegas, September 1999.
- [28] Ullman DG. The mechanical design process. 2nd ed. New York: McGraw-Hill; 1997.

**L. Zehtaban** is a Research Assistant at the Institute of Computer-aided Product Development Systems, Universität Stuttgart, Germany. She received her B.Sc. degree majoring in the Applied Mathematics and M.Sc. degree in Software Engineering. Currently, she is doing her doctoral research on the optimization of industrial procedures for product design and development, with specialization in the application-oriented similarity recognition

procedures. Her work covers similarity comparison applied for the optimization and reuse of design information in CAD/CAM systems.

**D. Roller** holds the position of director of the Institute of Computer-aided Product Development at the University of Stuttgart. He is full professor and chair of Computer Science Fundamentals. Additionally, he has been awarded the distinction as a honorary professor of the University of Kaiserslautern and also serves as member of the board of trustees of the Technische Akademie Esslingen.

He is chairman of several national and international working groups and former president of the ISATA forum, on of the world-wide largest technological associations, and also the leader of the experts group "Computer Graphics in Engineering - GRIB" of the German Computer Science Society. Presently, he serves as reviewer for several scientific organisations as well as for the Baden-Württemberg Ministry of Science and Research for project grants. He is also reviewer for well-known scientific journals and member of several national and international programme committees.

Prof. Roller gathered a comprehensive industrial experience as former research and development manager with world-wide responsibility for CAD-technology within an international computer company. He is the inventor of several patents and is well-known through numerous technical talks in countries all over the world, 71 published books and over 180 contributions to journals and proceedings books. With his wealth of experience, he also serves as a technology consultant to various high-tech companies.