

# Fast Equalization for Large Lithium Ion Batteries

Gerald Landrum  
Naval Oceanographic Office  
1002 Balch Blvd.  
Stennis Space Center, MS 39522 USA

Thomas A. Stuart and Wei Zhu  
University of Toledo  
2801 West Bancroft  
Toledo, OH 43606

**Abstract**-The use of Lithium Ion (LiIon) cells requires a battery management system to ensure that the LiIon cells can be operated safely and the battery pack will operate optimally. Lithium-ion batteries use an electrolyte that is flammable if exposed to high temperatures. Slight differences between the series-connected cells in a LiIon battery pack can produce imbalances in the cell voltages, and this greatly reduces the charge capacity. These batteries cannot be trickle charged like a lead acid battery because this would slightly overcharge some cells and would cause these cells to ignite. There are different methods used to ensure that the cells of a battery pack are not overcharged. The targeted equalizer (EQU) described here can be connected to any cell via a set of sealed relays to provide much faster equalization and higher efficiency than previous methods.

## I. INTRODUCTION

Because of their high energy density, Lithium Ion (LiIon) batteries are the preferred technology used in autonomous underwater vehicles (AUV). These cells are already widely used in numerous low power applications, and they are now finding many applications in large packs, where high power is required. The application described here is for the AUV shown in Figure 1.

The batteries used in this AUV consist of stacks of 3.6V, 60 Amp Hour (AH) high energy LiIon cells, each identical to that in Figure 2.

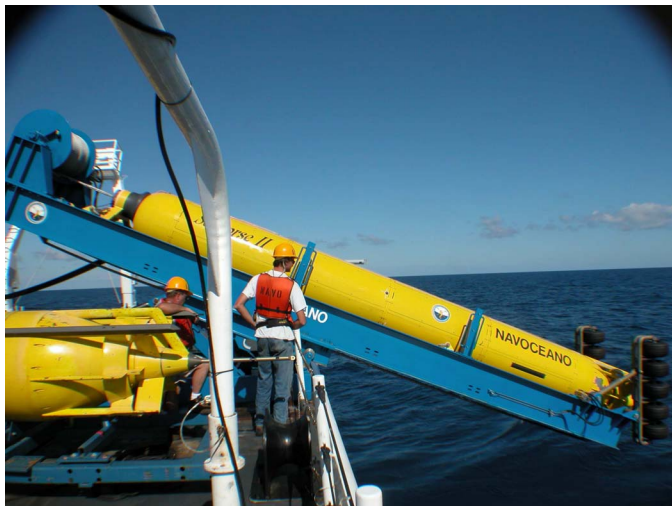

Figure 1. Seahorse II Autonomous Underwater Vehicle

There are a total of five parallel batteries, each containing 160 cells that are contained in cylindrical packages of 80 cells each, as shown in Figure 3.

To ensure safety and optimize performance, all cells must be monitored by an electronic battery management system (BMS). To reduce the size of the wiring harness between the BMS and the cells, the battery is divided into sets of several cells each. Each set has a separate Local control module. A Central module is then used to coordinate the individual Locals via a serial data link such as CAN (Controller Area Network). The block diagram for a typical system is shown in Figure 4.

Each of the Locals contains an electronic control unit (ECU) and an equalizer (EQU) that must provide at least the following functions:

1. Temperature measurements
2. Measurement of each cell voltage
3. Equalization of each cell voltage

Voltage and temperature measurements are fairly straightforward, but voltage equalization is more challenging, and several methods have been proposed [1-9]. Although it is the cell charge that must be adjusted to achieve equalization, voltage is used as the control variable because charge is proportional to voltage for LiIon batteries and voltage is much easier to measure. Equalization is necessary because slight



Figure 2. GAIA HE-602050 60AH Lithium Ion Cell

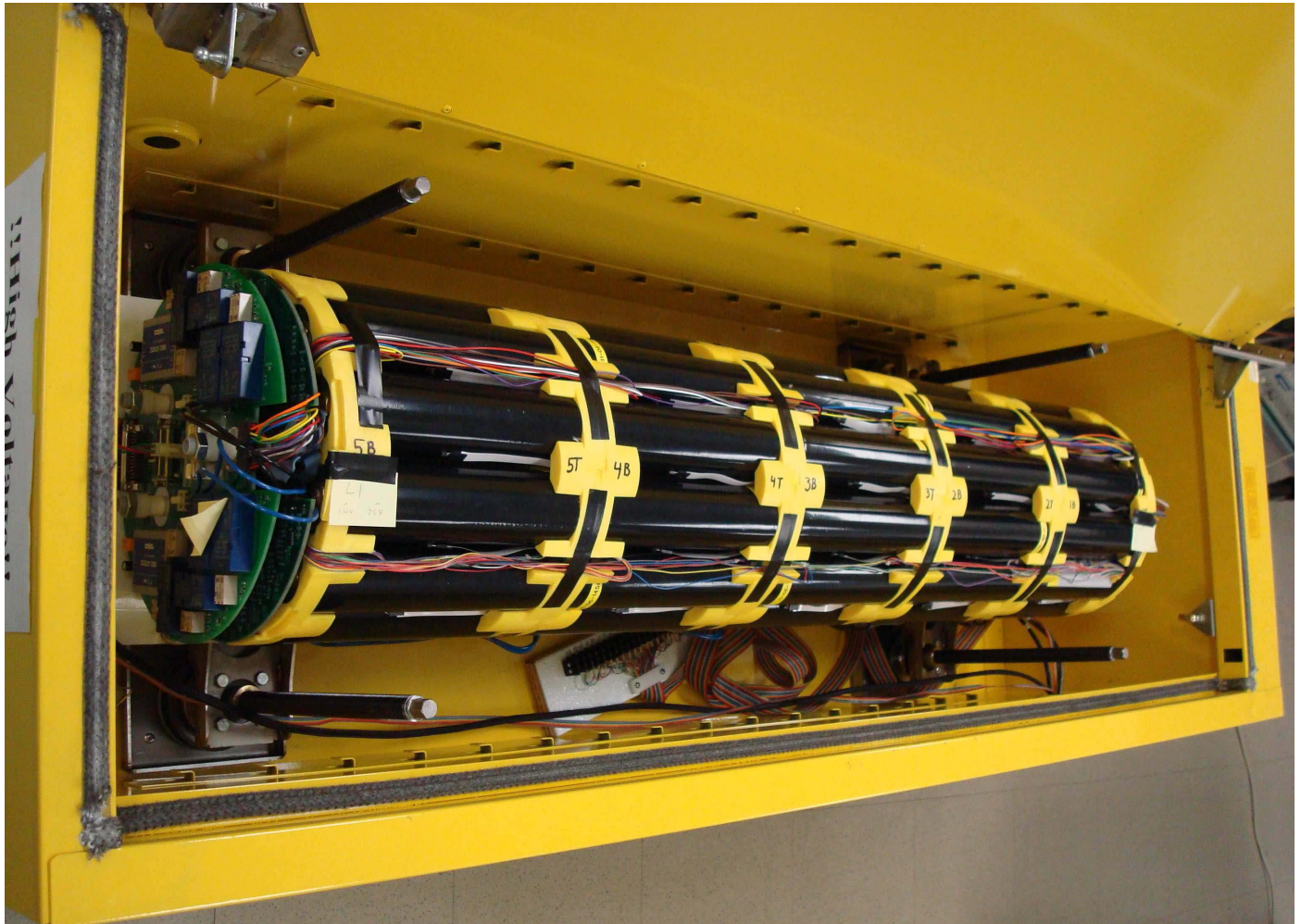

Figure 3. 80-Cell Lithium Ion Battery Pack

differences between the cells will cause their voltages to drift apart as the pack is charged and discharged. These variations also tend to increase as the pack ages and/or cells are replaced. Since charging is limited by the highest voltage cell and discharge is limited by the lowest, pack capacity will be determined by these two extremes. If equalization is not employed, this can eventually decrease the pack capacity by at least 25 to 30 percent. Equalization is fairly simple for many types of large batteries (e.g., lead acid or nickel metal hydride) because, after receiving a bulk charge, they can be trickle charged at a low current until all cells reach full charge. However, this means that some cells receive at least a slight overcharge, which is unacceptable for LiIon because this may lead to ignition of the cell.

This ignition problem means that an EQU for volatile cells such as LiIon must use an alternate method, such as charge transfer between cells as in [1-3, 8, 9] or equalizing the cells individually as in [4-7]. Charge transfer methods are intuitively appealing, but in practice they tend to be complex and rather inefficient for low voltage cells such as LiIon. Individual equalization is by far the most common, and most of these EQUs use a small resistor for each cell to discharge all cells to the lowest voltage in the pack. Although effective, discharge EQUs can produce excessive dissipation, especially if one cell

voltage tends to lag the others. Another problem is the excessive time required to achieve equalization because the EQU current must be kept fairly low to limit the total dissipation. In some cases, several hours are required to correct even a moderate imbalance.

Because of these problems, [5-7] proposed a method using a single EQU circuit that can be switched to target a cell via a set of sealed relays; hence, the term “targeted equalization.” This technique provides two important advantages:

1. It can either charge or discharge the cell to be equalized.
2. Because there is only one circuit, it can use a much higher current than EQUs with a resistor for each cell.

The circuit is relatively simple, and sealed relays are well suited for this application because the expected number of relay operations in this application is well below the typical specified value of 106 or 107 lifetime operations.

## II. EQU OPERATION AND COMPARISON

It is instructive to first compare the characteristics of the conventional discharge only (D) EQU and the targeted charge/discharge (C/D) EQU shown in Figures 5 and 6, respectively.

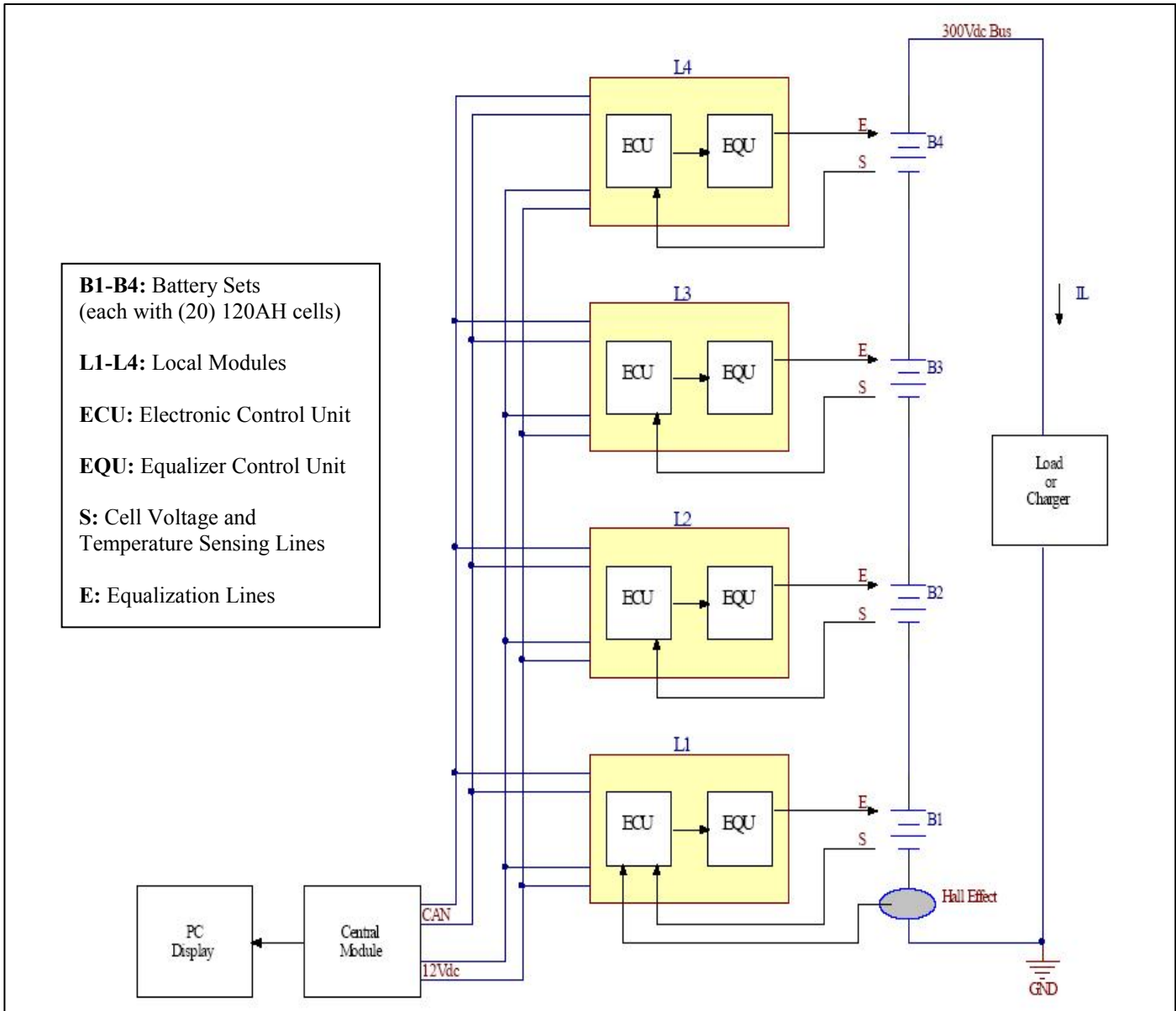

Figure 4. Modularized Battery Stack and BMS with Four Locals

The D type in Figure 5 has a transistor switched resistor, R1, for each cell, and therefore can discharge any number of cells simultaneously. It indicates the equalization current for one of the cells, B1. Because of the large number of power components, efficiency losses and heat generation typically restrict R1 to less than 1 or 2 watts. The strategy is to discharge cells until all equal the lowest cell voltage in the pack. Low power D type EQUs such as this are widely used, but because of restrictions on the total power loss, equalization may require tens of hours for even a moderate imbalance. After extensive use and/or cell replacement, differences between the cells will tend to increase, and more rapid and flexible equalization may be required. Some applications may also require fast charging, making the need for rapid equalization even more important.

The targeted C/D EQU in Figure 6 operates only on one cell at a time, but it can provide either charge or discharge equali-

zation current. The cell and choice of charge or discharge is determined by the Central module in Figure 4, and this information is sent to the Locals via the CAN link. The microcontroller in Figure 6 then sets the Selection relays and activates either the small charger, CH, to partially charge the targeted cell or Q1 to partially discharge it using R2. The power level of R2 can be much higher than R1 in Figure 5 because the single R2 is the only resistor to contribute to the total heat dissipation.

The cell charger, CH, in Figure 5 is selected to provide about the same current level as R2 since this matches the ratings of the relay contacts. It typically has an efficiency of at least 82% and therefore creates only minor heat dissipation. Although only one cell can be serviced at any time, it will equalize much faster than the EQU in Figure 5 due to the higher available current. As stated earlier, the strategy for the C/D EQU is to charge or discharge all cells toward the average cell voltage for

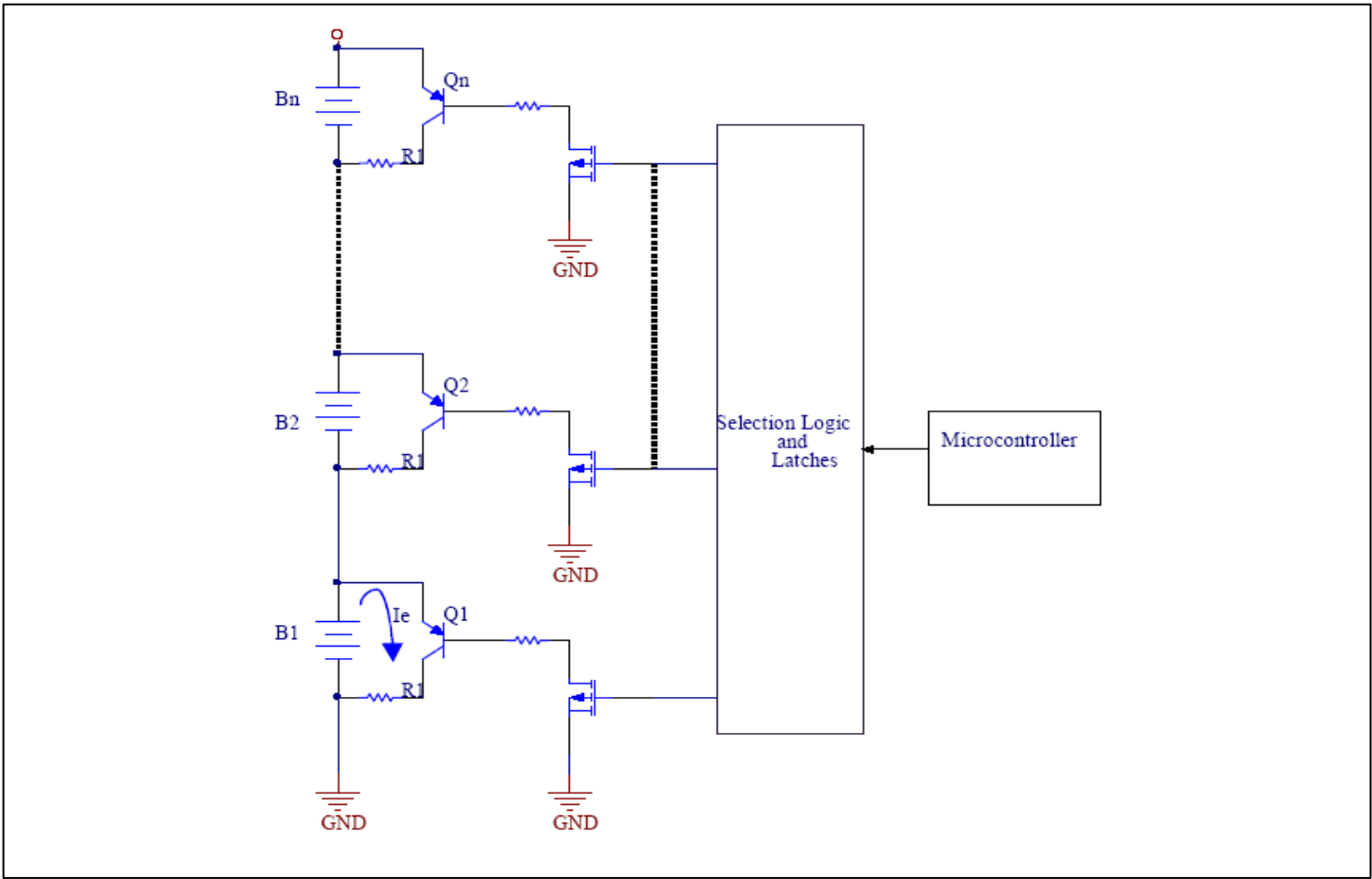

Figure 5. Conventional Dissipative EQU (D type)

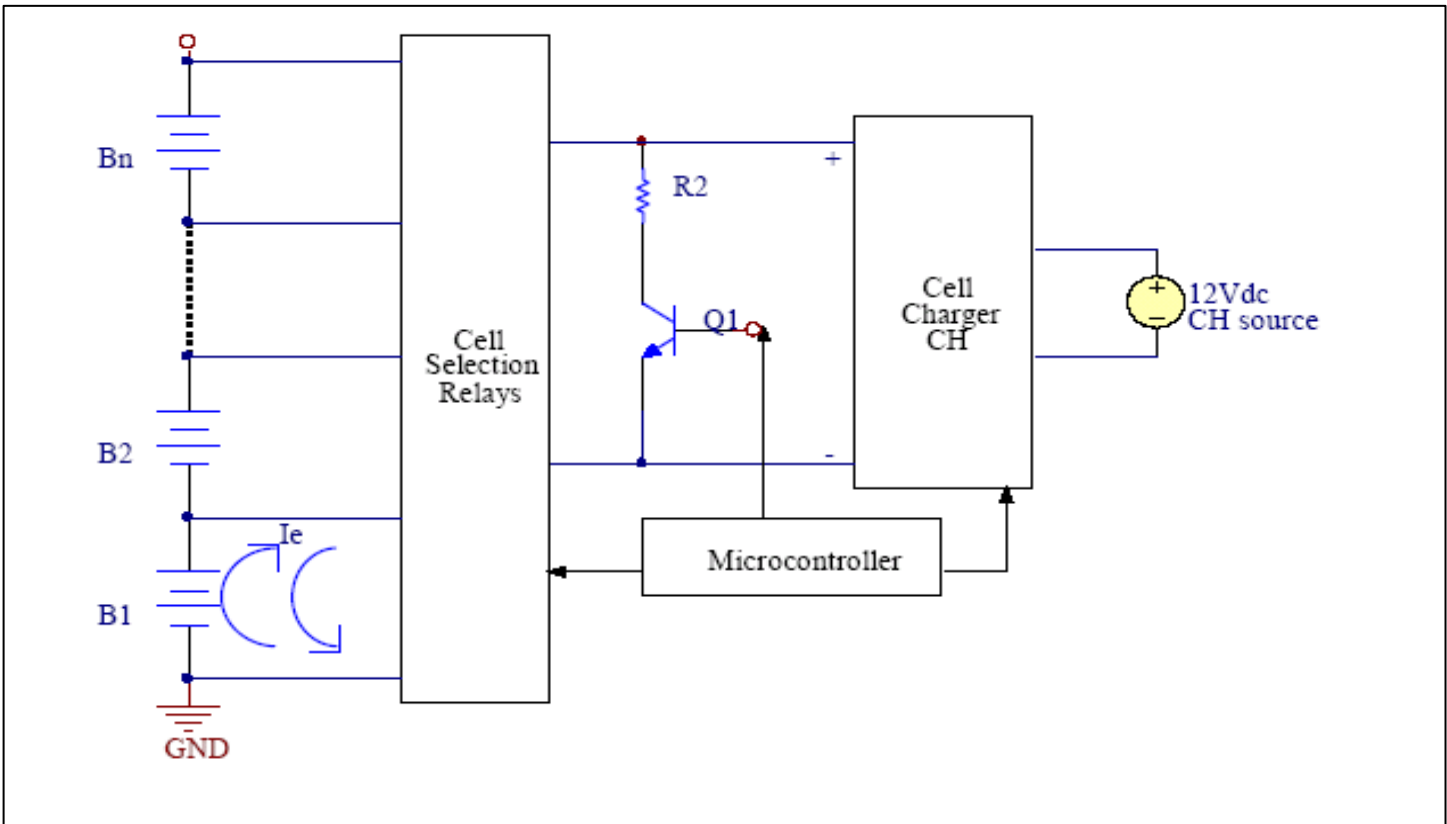

Figure 6. Targeted EQU System (C/D type)

the pack. As a result of decades of development for telecommunications and other demanding applications, certain types of sealed electro-mechanical relays now have very high reliability levels. The specified number of lifetime operations often exceeds 106 or 107, which is far above the expected number of operations for EQUs, especially since relay operation is infrequent once equalization is achieved. High manufacturing volumes also have reduced the prices of these devices, so these circuits can be very cost effective. Figure 7 shows an example contact arrangement that requires only five relays, X1-X5, for nine cells.

Experience indicates that usually only a few cells deviate significantly from the average cell voltage, but these voltages tend to be scattered above and below the average. Therefore, a targeted EQU only needs to process a few cells, as opposed to the D type, which has to discharge all cells to the level of the weakest cell in the pack.

### III. EXPERIMENTAL RESULTS

As discussed earlier, the BMS described here is intended for the Seahorse II AUV shown in Figure 1, which uses the GAIA HE-602050 60AH cell in Figure 2. One of the 160-cell batteries for this vehicle has been constructed using two of the

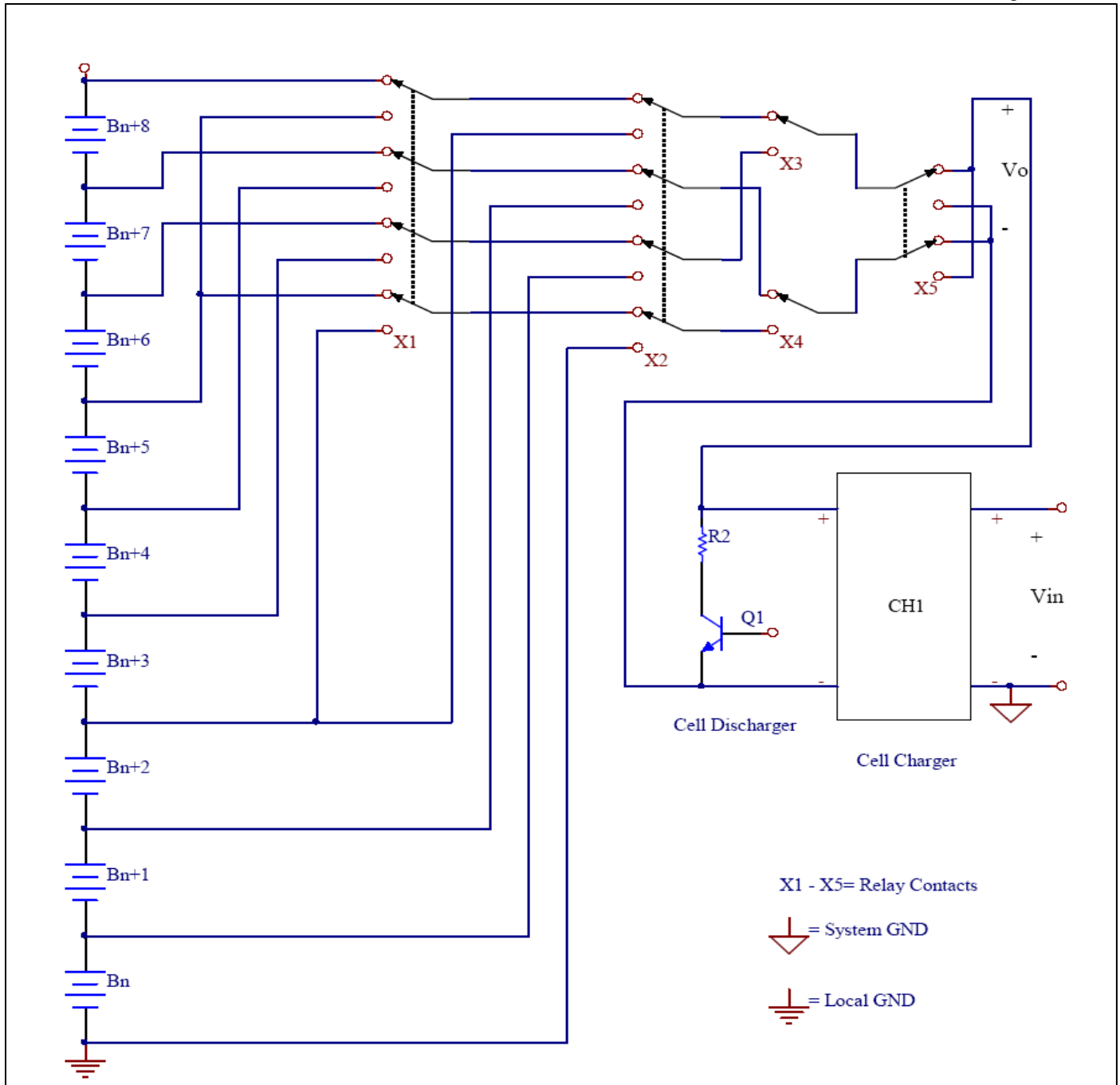

Figure 7. EQU Relay Arrangement for a 9-Cell Set

80-cell cylindrical packages shown in Figure 3. Each cell is connected directly in parallel with another to form a “super cell,” so a complete battery consists of 80 super cells connected in series. Thus, each of the four Locals in Figure 4 services 20 super cells. The full charge voltage of each super cell is 4.2 VDC, so the maximum battery voltage =  $80 \times 4.2V = 336VDC$ , and the maximum capacity =  $336V \times 120AH = 40.32$  KWH.

In this BMS, each of the four Local modules in Figure 4 actually has two EQUs, i.e., one for each half of the set. Therefore, each Local can equalize two super cells at the same time, meaning eight of the battery’s cells can be equalized simultaneously. The EQU circuit board for one of the Locals is shown in Figure 8.

The schematic for each of the two EQUs on the circuit board in Figure 8 is similar to that in Figure 7. The cell charger, CH1, is simply a Cosel ZUS251205 DC-DC converter, which has an output rating of 5VDC/4ADC. Because each cell voltage can vary from 3.0 to 4.2VDC, CH1 always operates in the current limit mode at a level slightly above 4ADC. CH1 must have galvanic isolation since the System ground and the Local ground are usually at different voltage levels. The discharge resistor R2 (0.67  $\Omega$ ) actually draws slightly less than 4ADC due to parasitic series voltage drops. In comparison, a D type EQU similar to Figure 5 typically would have to limit its cell discharge currents to about 0.1 to 0.2 ADC or less to reduce losses and/or temperature rise.

During the charging cycle, the Central in Figure 4 requests a new set of measurements and designates the cells to be equalized every 10 sec. Equalization could be done during charge, discharge, or at rest, but since the balancing provided by this EQU is quite fast, it is used only while charging.

Initial test results for one Local indicate very good performance, and the super cells can be maintained within  $\pm 10$

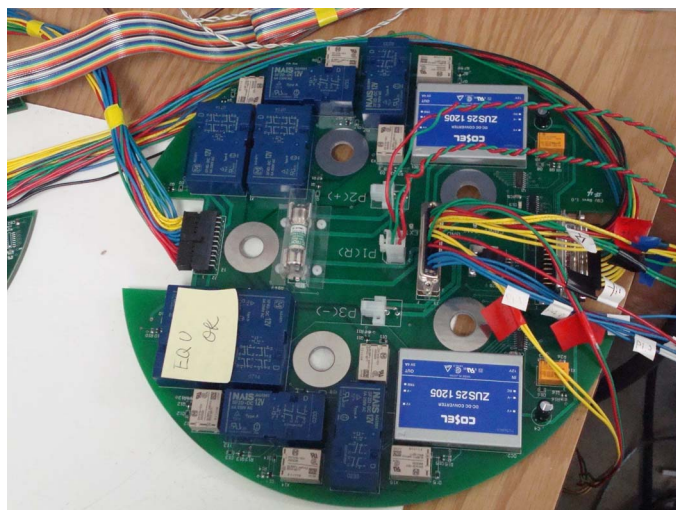

Figure 8. EQU Circuit Board

mV of the average cell voltage for the pack. Once the pack has reached a balanced state, operation of the EQU is infrequent,

and the equalization of a cell typically lasts for less than 1-2 minutes.

One issue observed during testing was the effect of different internal cell resistances. Discharging at a high rate can cause the cells with higher internal resistance to reach their lower cut-off voltage early. This can cause system shutdown before the battery is completely discharged. We are investigating using the boost equalization on discharge to overcome this issue.

#### IV. CONCLUSION

This more aggressive form of targeted charge/discharge equalization has certain obvious advantages over the more common technique of using a separate discharge resistor for each cell. These advantages include both faster equalization and lower losses. This technique is also much simpler and cheaper than proposed charge re-distribution methods that require power semiconductors and inductors or capacitors to transfer charge from cell to cell. Sealed relays are a good choice for connecting the EQU to the proper cell because these devices provide both high reliability and reasonable cost. Results for a prototype battery with 80 super cells have proven satisfactory, and a complete set of five batteries for the AUV is being developed.

#### REFERENCES

- [1] N.H. Kutkut, D.M. Divan, and D.W. Novotny (1995) “Charge equalization for series connected battery strings,” *IEEE Transactions on Aerospace and Electronic Systems*, 31, 2 (May/June 1995), 562-568.
- [2] N. Kutkut, H. Wiegman, D. Divan, and D. Novotny (1995), “Design considerations for charge equalization of an electric vehicle battery system,” *IEEE 1995 Applied Power Electronics Conference Proceedings*, Mar. 1995, 96-103.
- [3] T. Gottwald, Z. Ye, and T. Stuart (1997) “Equalization of EV and HEV batteries with a ramp converter,” *IEEE Transactions on Aerospace and Electronic System*, 33, 1 (Jan. 1997).
- [4] M. Tang and T. Stuart (2000) “A selective buck-boost equalizer for series battery packs,” *IEEE Transactions on Aerospace and Electronic Systems*, Vol. 36, pp. 201-211, January 2000.
- [5] T. Stuart, X. Wang, F. Fang, J. Pina, and A. Hande (2001) *A modular battery management system for HEVs*, U.S. Department of Energy Report NREL/SR-540-30244, April 2001.
- [6] X. Wang (2001) “A modular battery management system,” Ph.D. dissertation, The University of Toledo, May 2001.
- [7] T. Stuart, F. Fang, X. Wang, L. Ashtiani, and A. Pesaran (2002) “A modular battery management system for HEVs,” *SAE 2002 Future Car Congress*, Paper No. 07FCC-422, Arlington, VA, June 2002.
- [8] Y. Lee and G. Cheng (2006) “Quasi-resonant zero-current switching bidirectional converter for battery equalization applications,” *IEEE Transactions on Power Electronics*, Vol. 21, No. 55, pp. 1213-1224, September 2006.
- [9] Y. Arai and K. Yamamoto, “Method and apparatus for equalizing secondary cells,” U.S. Patent 2006/0214636A1, Sept. 28, 2006.

*The inclusion of names of any specific commercial product, commodity, or service in this paper is for information purposes only and does not imply endorsement by the Navy or NAVOCEANO.*