

Smart Phone Compatible Peak Expiratory Flow Meter

S. Natarajan -*IEEE Student Member*, J. Castner, and A.H. Titus -*IEEE Senior Member*

Abstract— Asthma is a chronic air way inflammatory disease that restricts airflow in lungs through acute reduction of airway by a combination of smooth muscle constriction, swelling, and increased mucus secretion. While there is no cure for asthma, the disease can be controlled by avoiding or removing triggers, closely monitoring lung function, and medication management. The home environment is essential to the prevention, control, and treatment of asthma. Home care includes self-monitoring using peak expiratory flow (PEF) device and a written asthma action plan. A peak flow meter is used to measure the volume of forced exhalation, and is a reliable and objective measure to signify potential onset of exacerbation before symptoms are felt, determine the severity of exacerbations, and evaluate treatment. Existing peak flow meters require the user to remember and follow the procedure to take peak flow measurements and thus have reduced compliance. In this paper we propose a low cost, portable, smartphone compatible peak flow meter design that connects to a smartphone through the audio jack.

Keywords—Asthma; Home care; Peak flow meter.

I. INTRODUCTION

Asthma is a chronic air way inflammatory disease with episodes of “attacks.” During an asthma attack, airflow in the lungs is restricted as the airway diameter is acutely reduced by a combination of smooth muscle constriction, swelling, and increased mucus secretion. Asthma attacks can be deadly. In 2013, approximately nine people died each day from asthma in the United States. While there is no cure for asthma, the disease can be controlled by avoiding or removing triggers, closely monitoring lung function, and medication management. Diagnosis for asthma and their significance is explained here [1].

Asthma is associated with significant illness, quality of life, and cost implications. Currently, asthma affects over 8% of the United States population. In 2009, there were 2.1 million emergency department visits for asthma exacerbation, indicating widespread poor control over asthma attacks. The prevalence and impact of asthma is detailed here [2] and here [3]. Asthma is a leading cause of missed school or daycare for children. The Centers for

Research supported by the University at Buffalo Center for Excellence in Home Health and Well-Being through Adaptive Smart Environments (Home-BASE) (<http://ubhomebase.org>).

S. Natarajan is with the Department of Electrical Engineering,

S. Natarajan is with the Department of Electrical Engineering, University at Buffalo, The State University of New York, Buffalo, NY, 14260 (email: srinathn@buffalo.edu).

J. Castner is with the School of Nursing, University at Buffalo, The State University of New York, Buffalo, NY, 14260 (e-mail: jcastner@buffalo.edu).

A. H. Titus is with the Department of Biomedical Engineering, University at Buffalo, The State University of New York, Buffalo, NY, 14260 (phone: 716-645-1019, fax: 716-645-2207, email: ahtitus@buffalo.edu).

Disease Control and Prevention report that more than 60% of children and over half of adults with asthma had to limit their usual activities in the last year because of uncontrolled asthma. Over one third of adults with asthma had missed work in the last year because of the disease. The annual economic burden of asthma, including healthcare costs and lost productivity, is estimated at \$56 billion. The prevalence and negative impact of asthma in the United States is growing.

The home environment is essential to the prevention, control, and treatment of asthma. Home care includes self-monitoring using peak expiratory flow (PEF) device and a written asthma action plan. A peak flow meter is used to measure the volume of forced exhalation, and is a reliable and objective measure to signify potential onset of exacerbation before symptoms are felt, determine the severity of exacerbations, and evaluate treatment. Monitoring of peak flow trends allows for the detection of exacerbation earlier than symptom monitoring alone, allowing opportunities for earlier intervention before an asthma attack becomes out of control. The asthma action plan establishes categories and recommendations for medication use and healthcare utilization based on either ongoing peak flow measurements or perceived symptoms.

There are several barriers to the proper use of currently existing peak flow meters. Most asthmatic patients do not recall receiving a PEF meter or asthma action plan from their healthcare provider. [4] explains scenario of adherence to asthma plan. Previous studies reveal approximately one-fourth of patients can properly demonstrate the steps to PEF measurement, and providers fail to review or demonstrate the steps during clinical visits. Taking the measurements twice daily can be easily forgotten and paper-based diaries to record findings can be easily lost. Frequent, automated reminders, electronic instructions with human factors engineering displays, ergonomic design, and electronic recording of the PEF information is warranted to facilitate adherence and meaningful use of the PEF device and asthma management.

In this paper, we present the initial development of a low-cost PEF meter that will be compatible with a smart phone. This device and associated app will help maintain regular peak flow meter use and simplify the recording of results from the daily tests.

II. PEAK FLOW DEVICES

A. Existing Peak Flow Devices

Existing PEF devices are available as simple mechanical flow meters or as advanced electronic flow meters that could be connected to a personal computer for data storage and transmission. The simple mechanical peak flow meters are

available at affordable costs compared to the digitized devices. Invariably all these devices require the users to exhale or blow as hard as possible into the device following maximum inhalation. The devices can be classified into five major categories based on their operating principle namely: variable orifice meters, fixed orifice meters, ultra sonic meters, stator-rotor meters and pneumotachograph meters, of which variable orifice mechanism is used widely in the mechanical devices. The electronic devices primarily make use of the stator-rotor mechanism.

Based on the working mechanism of the device, the devices convert the airflow from the user's mouth into flow rates, which are typically reported in terms of Liters Per Minute (LPM). The airflow readings provide a measure of the airway restriction in the user. The user takes measurements two to three times a day as prescribed by a physician. Each measurement requires the user to take three readings and note down the best reading. The devices have red, yellow, and green zones marked along the LPM calibration, which ranges from 0-800 LPM. A reading that falls within the red zone denotes a danger situation suggesting immediate attention. A reading in the yellow zone denotes a risky situation in which the onset of worsened asthma conditions is likely, and a green zone reading denotes a healthy airway. Since the amount of flow that represents a healthy airway depends on the user's age and sex, the yellow and red zones are based on the user's green zone reading, which is determined upon initial use for a healthy reading. The readings are used by the user to determine what, if any, action is needed according to the user's personal asthma action plan.

B. Drawbacks of Existing Systems

The amount of work expected from the user in order to keep track of asthma condition reduces user compliance with the existing devices. Research here [5] addresses adherence of patients to peak flow monitoring. The existing devices require the user to remember to take the number of readings as prescribed each day- a task that becomes irregular over time. If the user opts for the low cost devices, which are predominant, the workload increases to taking down readings in a diary or a peak flow chart provided along with the devices. The higher cost devices are capable of data storage and also aid in plotting weekly PEF charts, but the high cost of these devices restricts the technology from being delivered to all people. Additionally, even when mechanical devices are available, the compliance issue still exists. Finally, existing electronic peak flow meters cannot provide periodic reminders and alerts, recommend medications depending on the asthma scenario and so on.

III. SMARTPHONE COMPATIBLE DESIGN PRINCIPLE

In order to bridge the gap between cost and performance, we decided to use the limitless software capabilities of one of the most ubiquitous tools that a vast majority of the world's population now has: the smartphone. If the PEF was made smart phone compatible, features such as alerts and reminders, medication recommendations, data logging, connecting with physician, interactive touch interface etc.,

all could be implemented. *My Spiroo* [6] is a device similar to ours; the smartphone compatible spirometer prototype information is available, but there is no information on the cost or date of product release.

We are working on developing a relatively low cost alternative to electronic PEF devices that can connect to the smartphone through the audio input/output jack. This concept has been shown here [7]. The mechanism used in our system to convert airflow into an electronic component is the fixed orifice method. The fixed orifice method was chosen over the other mechanisms because by using this method, the cost of the device could be almost restricted to the cost of the pressure sensor. In the fixed orifice method, air is made to flow through a pipe containing an orifice. The dynamics of fluid (air) flow is straightforward, and we provide a summary explanation as follows. The initial flow of compressed air is assumed to be laminar, so that the flow is proportional to the pressure of the fluid (air). As the air reaches the orifice plate (divider disk with hole, as shown in Figure 1), turbulence is created in the flow because of the change in diameter. This forces fluid pressure to decrease to allow the fluid flow through the orifice. The orifice thus creates a pressure drop in the air (See Figure 1) This pressure change between the two sides of the orifice is now proportional to the square of the airflow and is given by the equation

$$Q = C_f A_0 (2\Delta P / \rho)^{1/2} \quad (1)$$

where Q is the flow rate in LPM, C_f is a constant based on ratio of pipe diameter to orifice diameter, A_0 is the area of the orifice, ΔP is the pressure difference on either side of the orifice and ρ is the density of the fluid (air). Our goal is to design two peak flow tubes with the same circuit to match two different ranges: 90-500 LPM and 300-800 LPM for child and adult users, respectively.

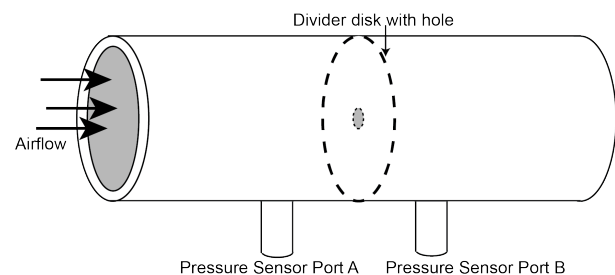

Figure 1. Schematic of fixed orifice method with two sections of pipe separated by a thin wall with a small hole.

The drop in pressure is converted into a voltage by a suitable pressure sensor. The voltage is amplified and fed as the control voltage for a voltage controlled oscillator (VCO). Thus, a frequency corresponding to the flow value is fed into the smartphone through the audio jack. This frequency can then be accessed using the framework in the mobile platform's development tool through a custom-designed application. Thus the frequency can be mapped with the flow values, calibrated and the app can be coded to display and store flow values for the corresponding frequencies.

IV. SYSTEM DESIGN

Our system consists of four sections as represented in the block diagram in Figure 2.

A. PEF Tube

The PEF tube is the tube through which the user blows into in order to measure peak flow. The initial design for lab testing is made from 1/2" PVC pipes. Our PEF tube is constructed from two short lengths of PVC pipe with a thin disk containing a small (~1mm) hole sandwiched between them (see Figure 3). Two ports were made on either side of the orifice by drilling holes in the PVC pipe and fixing plastic ports in them. The plastic ports are then connected to a pressure sensor by means of flex tubing. When testing is complete, the next version will be fabricated using a 3-D printer; this version will be used for asthma patient studies.

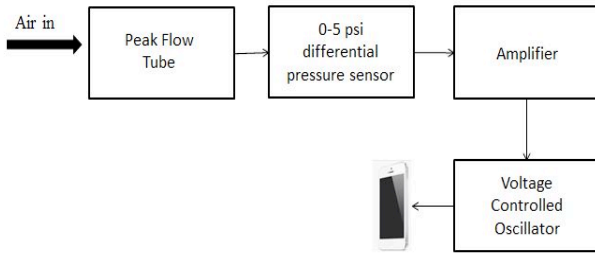

Figure 2. System Block Diagram

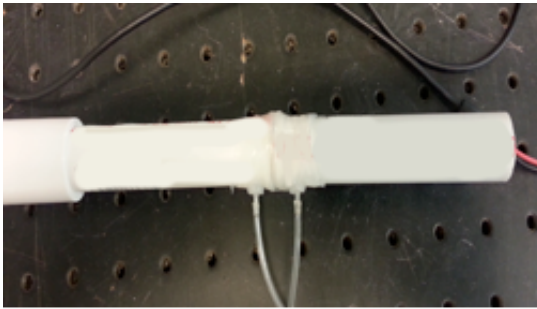

Figure 3. PEF tube made with PVC, including outlet port tubing.

B. Pressure Sensor

We use an off-the-shelf Honeywell differential pressure sensor (TSCSNBN005PDUCV) to convert the pressure drop to a voltage. For the flow rates of interest, the operating pressure drop was found to be between 2-3 psi. This differential pressure sensor has a range of ± 5 psi, so it is well suited to the pressure measurement range.

C. Amplifier

The small voltage output from the pressure sensor is a differential output voltage, so it is amplified using an instrumentation amplifier. The schematic of the amplifier is shown in Figure 4. To simplify future work, a single supply

INA122 was selected. The amount of amplification is controlled by the choice of resistor; for our design, we require a 3k Ω resistor. The amplified voltage, V_{out} , is then fed into the VCO as the control voltage.

D. Voltage Controlled Oscillator (VCO)

The VCO is designed using a standard 555-timer chip (NE555). The schematic of the VCO is given in Figure 5. The oscillator responds with a frequency that corresponds to the control voltage from the amplifier, V_{in} . The oscillator is designed to provide frequencies in such a way that most of the smartphone's frequency spectrum (20 Hz – 20 kHz) is utilized and better sensitivity is achieved. The output of the VCO is a square wave whose frequency varies with input flow rate (pressure).

V. TESTING AND RESULTS

The system is built and tested in the laboratory. In order to verify proof of the concept, we test the system by simulating human subjects blowing into the pipe by using compressed air. Compressed air tanks are fitted with airflow regulators that allow controlled release of air from the high-pressure tanks. One of the most widely used PEF devices, called the *POCKET PEAK* was used for validation of airflow for our device.

The *POCKET PEAK* is connected to the air tank and the airflow rate is set at different values. We then record the flow rates from the device for the corresponding flow rates at the tank. Subsequently, we connect our device to the tank, set the flow rates, and record the corresponding frequency values for each flow rate step. For all cases, the flow values start at 300LPM and increased in steps of 50 LPM. The results are shown in Figure 6. While not perfectly linear, the response is monotonic, and calibration can easily correct for any nonlinearity. Also, the output frequency range is from 5kHz to approximately 17 kHz, which covers most of the

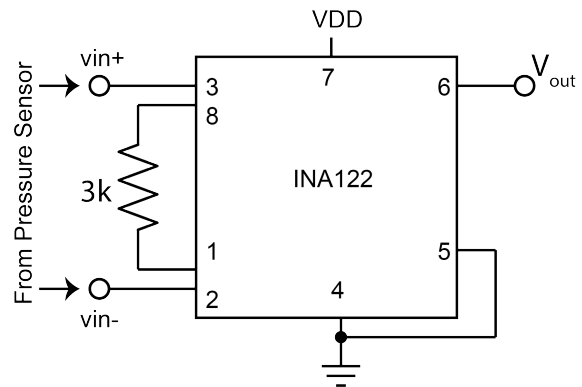

Figure 4. Amplifier schematic.

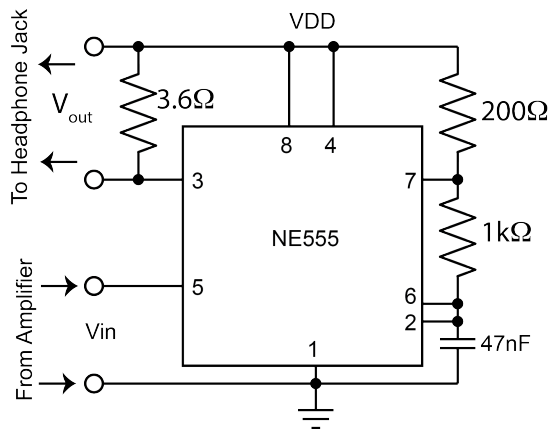

Figure 5. Voltage Controlled Oscillator Schematic

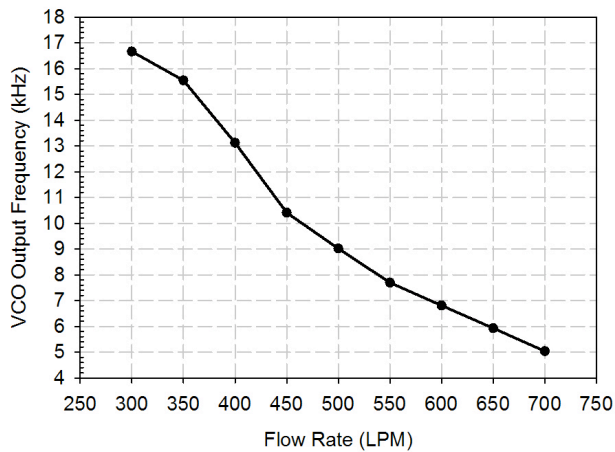

Figure 6. Output frequency from the VCO as a function of flow rate.

frequency range of the smartphone, and thus enables us to achieve high sensitivity.

In order to verify that the system can successfully communicate the oscillating voltage signal through the audio jack to the smartphone, the VCO output was connected to the audio jack using a TRRS cable. An iPad original, iPad mini retina display and Samsung galaxy note II were used. Testing method involved a Skype call made from one device to the other and changing the airflow level. Different audio tones were heard for different flow levels on the receiving device clearly indicating possibility of recording PEF values in the smartphone device.

VI. CONCLUSIONS

We have demonstrated a straightforward PEF device that requires no moving parts and is capable of being connected

to a smartphone device for automated recordings of PEF readings. Based on these tests, we can create 3-D printed versions of the physical device for asthma patients to test. Continuing work also includes the app development and adjustment of output impedance matching.

The connection to audio jack of Samsung galaxy note II showed no problems, but the development feasibility for android could not be easily assumed from this, as there is a sea of android devices available in the market and each one has to be tested. Developing for iOS is more universal and hence we will be developing the PEF meter for Apple devices.

The major challenge with Apple devices is that different versions of apple devices expect different impedances at the audio jack in order to recognize the connected TRRS cable as a headphone with microphone. We had to find this out using trial and error. The iPad original requires 3.6Ω impedance, whereas the iPad mini RD required around 900Ω. This poses serious limitations in developing a universal design as the output frequency of the VCO changes well with the drastic change in impedance.

In the future work, we will also focus on adjusting the PEF tube to make it suitable to measure the lower PEF range of a child (airflow ranging from 90-500 LPM) while using the same electronics.

REFERENCES

- [1] Kaplan, Alan G., et al. "Diagnosis of asthma in adults." *Canadian Medical Association Journal* 181.10 (2009): E210-E220.
- [2] Abisheganaden, John. "Asthma: The Need for Good Control." *Annals of the Academy of Medicine, Singapore* 38.7 (2009): 567-562.
- [3] Centers for Disease Control and Prevention (CDC). "Vital signs: asthma prevalence, disease characteristics, and self-management education: United States, 2001--2009." *MMWR. Morbidity and mortality weekly report* 60.17 (2011): 547.
- [4] Boulet, Louis-Philippe, et al. "Adherence: the goal to control asthma." *Clinics in chest medicine* 33.3 (2012): 405-417.
- [5] Halimi, Laurence, et al. "Severe asthma and adherence to peak flow monitoring: longitudinal assessment of psychological aspects." *Journal of psychosomatic research* 69.4 (2010): 331-340.
- [6] <http://www.myspiroo.com/#intro>.
- [7] Bumatay, Antoinette, et al. "Coupled mobile phone platform with peak flow meter enables real-time lung function assessment." *Sensors Journal, IEEE* 12.3 (2012): 685-691.